



Bishops is proud to present the new edition of our market leading:

Industrial & Safety Catalogue.

Within these pages are over 15,000 products sourced from over 100 leading brands, and collectively reflects the comprehensive range of products Bishops stocks in Papua New Guinea.

This catalogue will prove to be your invaluable companion as you search for all the *little things* you need to get whatever job you're working on, done.

It contains detailed product descriptions and specifications, coloured images, and Bishops' part numbers to make researching and ordering as easy as possible for you.

Please enjoy, and keep it close!

Welcome to the new edition of the Bishops Industrial & Safety Catalogue

Bishops is a family-owned, proudly PNG business, that's been partnering with local businesses to grow PNG's industrial output for more than 50 years.

How? By providing local businesses with all the "little things" they need to help build, operate, maintain and repair their 'assets' – whether that's a truck, a small workshop, or a large mine site – and to kit out and keep all the people that they employ safe.

We do this by sourcing and supplying only the highest quality workwear, PPE, tools and equipment to meet your exacting standards, and that long list of consumables – whether they be fasteners, lubricants, hydraulics, bearings, lifting, janitorial, crib, etc – that you need day-in-day-out to get the job done.

This catalogue contains more than 15,000 of these "little things", all collated into easily digestible categories for easy reference, reflects the broad range of things Bishops stocks in-country, and is why when any local is asked: "Where can I get it from?", they will reply: "Get it from Bishops".

Let's talk about stock for a moment. We have more than K50 million of stock invested in our 2 DC's (Port Moresby and Lae) and our 4 regional branches (Mt Hagan, Madang, Kimbe and Kokopo). This investment underpins our service promise to you of getting what you need, where you need it, fast and reliably. And there's no-one else that delivers upon that promise to you better than Bishops.

So, if you're an existing customer – thank you. We hope you'll find this new edition of our market-leading catalogue an invaluable new sourcing companion. If you're new to country or haven't yet "got it from Bishops", please absorb these pages to appreciate the "little things" we can provide to you, then come in and pay us a visit.

If you can't find what you really need within the pages of this catalogue, don't despair, more often than not, Bishops will source it for you, meaning everything you need is at this one-stop-shop.

On behalf of all the team at Bishops, enjoy your new sourcing companion that is this catalogue, which is also available electronically on a USB, and available online at www.bishopbros.com.pg.

And please, keep it close.



Jason Johnson
Executive Chairman, Bishops



The Bishops Difference

For more than 50 years, the team at Bishops has proudly watched PNG grow – through Independence, the PNG LNG project, and the myriad of industries that have started and flourished in this rich land.

And the biggest contribution Bishops has made to PNG's growth has been supporting you with locally supplied stock of all the *"little things"* you've needed to get started and grow.

Walk into any Bishops branch and you'll see just a small fraction of what we hold in stock within our warehouses "out the back", and these warehouses reflect just another fraction of what Bishops is capable of sourcing for you, fast, through its unrivalled access to more than 100 leading brands, and international markets.

By supporting you, we've grown ourselves – to become the largest and most trusted brand for the supply of all the *"little things"*, the tens of thousands of products across a broad range of categories, that we call Industrial & Safety.

All of this has been achieved because of what makes us *different* from any one else, including:



Investing in and maintaining more than K50 million of stock in country, ensuring you can get what you need, reliably and fast



Developing a dedicated sourcing team to procure on your behalf when we don't (yet) have what you need in stock – from anywhere in the world



Building a market-leading catalogue and website through which to search for all the most commonly asked-for products, making it easy for you to find, research, and order



Sourcing and supplying you with only the highest quality products – whether that be workwear and PPE complying with Australia's exacting safety standards, hand tools that come with a life-time manufacturer's guarantee, or industrial-grade equipment tried and tested in PNG's harsh working environment



Training our local team with technical knowledge to guide and support you when you're not quite sure what products will meet your needs



Building systems that enable our team to turnaround quotes fast, expedite your orders, and get them delivered directly to you, giving you full and proactive transparency throughout our supply chain so you know what's coming and when



Working with you to consolidate what you buy around quality, fit-for-purpose products, and introducing you to innovative new products as they are brought to market



Fixing a competitive discount for you on all your commonly purchased products so you have the comfort of knowing you're always buying competitively, even as supplier price inflation flows through



Streamlining your ordering and payment process, removing unnecessary touchpoints to make it as painless as possible for you

Most importantly, we see our relationship as a Partnership.

We supply and do all the "little things" to enable you to stay focused on your big picture – whether that's running a small workshop or building PNG's next "great asset".

We are here to serve you, and we look forward to shaking hands to begin...

In-House Services



Embroidery

Allow Bishops to take your brand to the next level with our embroidery service. We have your needs covered, be it embellishing pieces with your company logo or personalising uniforms with staff names.

We will take your design from digitising right through to the finished product. All steps are done in-house at our Port Moresby and Lae branches, ensuring quality and attention to detail throughout the entire process. We'll even source and supply you with the garments, saving you time to get back to the job at hand.

Our embroidery service is available on all clothing and caps, giving your team that professional touch.



Lifting Inspection & Testing

Reduce the need to search for multiple services – Bishops bring all this to you in one central location with our in-house sling manufacture and testing.

From our warehouse in Port Moresby, our sling manufacturing and testing is at an easily accessible location and of the highest standard. We manufacture and test chain, wire rope and synthetic slings, in accordance with Australian Standards, up to 200 tonnes. We can also test your lifting and rigging equipment.

We provided you with certification on all our manufacturing and testing, assuring you and meeting your workplace safety requirements.



Hydraulic Hose Manufacture

Make Bishops your go-to partner for all your hydraulic hose and fittings needs. Bishops can conduct on-site inspections, provide you recommendations, and manufacture and supply hoses tailored to suit your requirements, reducing your downtime and saving you at your bottom line.

With an extensive range of tools, oils and sundry products stocked at our conveniently located warehouses, Bishops have what you need to make changing out hoses and fittings quick, easy and cost-effective.



Torque Wrench Calibration

Unmaintained tools make an unsafe workplace. Ensure your team's safety and engage Bishops in-house Torque Wrench Calibration Services at Port Moresby. We have the facility to test and re-calibrate all types and brands of torque wrenches and will provide you with the required certification, ensuring your equipment is up to the job every time.



Enerpac Hydraulic & Pneumatic Equipment Testing, Calibration & Repairs

We've partnered with leading brand Enerpac to bring you the highest quality in servicing your hydraulic tools. With specially trained staff, Bishops have the facility to carry out inspections and troubleshooting on your hydraulic equipment. We can bring our expertise to you on-site at your location or visit us at one of our warehouses.

Get the complete service for all types Enerpac equipment at our Port Moresby branch, where we offer strip and repair services, along with testing and calibration on completion.

Warehouse Locations

Opening hours for all warehouses are:

Monday to Friday: 8am–5pm

Saturday: 8am–12 noon



Port Moresby

Warehouse & Head Office

Wards Road, Hohola

Phone: (+675) 325 1088

Fax: (+675) 325 1083

Email: sales@bishopbro.com.pg

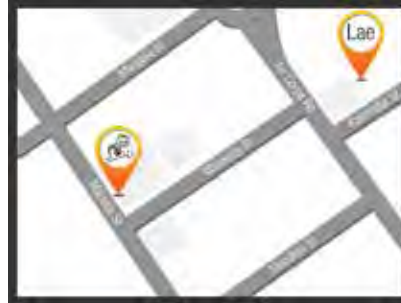

Lae

Cnr Malaita & Malekula Street, Lae

Phone: (+675) 472 3799

Fax: (+675) 472 6327

Email: laesales@bishopbro.com.pg



Kimbe

San Remo Drive, Kimbe

Phone: (+675) 983 5500

Fax: (+675) 983 5306

Email: kbesales@bishopbro.com.pg



Kokopo

Karmuk Street, Kokopo

Phone: (+675) 982 9911

Fax: (+675) 982 9912

Email: rabsales@bishopbro.com.pg



Madang

Kaisian Avenue, Madang

Phone: (+675) 422 1344

Fax: (+675) 422 1594

Email: mdgsales@bishopbro.com.pg



Mt. Hagen

Okuk Highway, Mt Hagen

Phone: (+675) 545 1990

Fax: (+675) 545 1019

Email: hgnsales@bishopbro.com.pg



Our Website

Keep up to date with the latest news about Bishops, see the latest products offerings, event information or get in contact with your local Bishops store.

The website also provides free product resources and reference guides to use in your workplace.

Visit www.bishopbro.com.pg to begin your journey.

Our People

In 50 years of operations in Papua New Guinea, Bishops has grown from a small company with a minimal staff, to now employing over 300 staff across the country.

The staff at Bishops represent a valuable and important part of our community, fulfilling important roles within the company, particularly when it comes to providing excellent customer service to both our customers and suppliers.

Bishops prides itself on training and developing our local staff. In recent years, our employees have been developed and promoted to branch managers, warehouse managers, and purchasing supervisors, effectively reducing significantly the number of expatriate staff required.

Every effort is made to continually identify and develop the best of the local talent available, keeping jobs in the country with the benefits flowing back into the local communities.

Bishops has many stories to share relating to staff development, where young men and women have entered the business at the ground floor and by hard work, training and mentoring, individual effort and a desire to succeed, now see these Bishops people in leading company roles.

As an equal opportunity employer, every effort is made to develop all our people to not only service the Bishops business and our customers, but to promote and share their learnings with family and friends in the community.

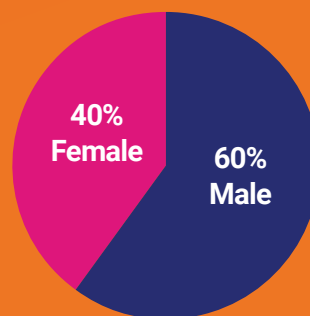
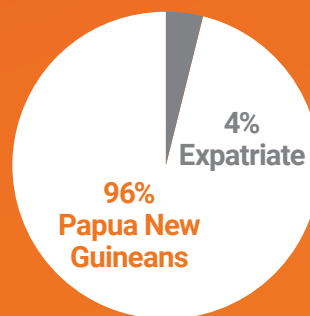

Supporting Our Community

Our staff make our company what it is, therefore we like to support them through not only training and guidance, but also through the sponsorship in various local competitions around the country.

96% of our staff are Papua New Guinean, which is why the communities surrounding our company are so important to us.

Bishops has developed into what it is today through the custom and support of these communities and views its obligations to the people and cultures of PNG as highly important. At Bishops we try to reflect the support given to us by giving back to the community, and over several decades have become involved in numerous sports and cultural sponsorships.

With increased engagement in our local communities, we trust this comes back to excel in our service and commitment to you, our customer.



Ethical Sourcing & Modern Slavery Statement

Bishops Code of Conduct and related initiatives are committed to high standards of ethical behaviour, from day to day business interactions to Community Engagement initiatives.

Bishops is steadfast on eradicating modern slavery from our supply chain by seeking to do business with suppliers that are aligned with our values, ethics and environmental practices.

Bishops acknowledges the responsibility we have in promoting ethical and sustainable business practices for not only ourselves, but all other stakeholders throughout our supply chains. Human rights is of significant importance to all of Bishops' employees, customers and communities surrounding the locations we operate in, and as such Bishops is committed to a journey of ongoing and continuous improvement to ensure the risk of modern slavery within our supply chains is minimised.

SEDEX GLOBAL

Bishops have partnered with Sedex Global to help manage our ethical sourcing commitments. Sedex provides Bishops with an ethical platform where we can operate responsibly and sustainably.

Sedex allows Bishops to maintain data on ethical and responsible practices in four key areas:

- Health and safety standards
- Labour standards
- Environmental impact
- Business ethics

In addition, Sedex is an accredited host of SLCP (Social & Labor Convergence Program) providing a joint assessment framework that aims to improve working conditions in the global apparel and footwear supply chain.

SUPPLIER RISK ASSESSMENT QUESTIONNAIRE

We set clear expectations of our suppliers to conduct business in a manner that is ethical and sustainable, and we make known our complete opposition to slavery in all forms.

As part of our Supplier Assurance Programs facilitated by Sedex, we engage with our suppliers through our Supplier Risk Assessment Questionnaire. These assessments are used to understand our suppliers' risk assessment process, their own policies, actions and commitments in relation to reducing the risk of modern slavery in their own supply chains.

As a reseller, we purchase from reputable third party suppliers who are expected to operate in a safe and ethical manner whilst respecting human rights. We expect these suppliers, as manufacturers, distributors and service providers, to have policies and programs in place to address modern slavery risks within their own supply chain.

Bishops recognises that tackling modern slavery will require a sustained, ongoing and meaningful commitment, and will continue to work with internal and external stakeholders to address our role in minimising the risk across our supply chain.

Using The Catalogue

Find it in the Section

The catalogue is divided into 15 sections, such as Safety Equipment & Consumables, a Reference section and an Index. Each section is indicated by a different colour tab and has its own cover page. The section cover page has a quick contents detailing the main product categories within that section, and the pages you will find them on.

Within the section, the title of the each page will detail the broad product groups shown on that page.

Find it in the Index

Located at the rear of the catalogue is a comprehensive alphabetical index. Use this as you would any other index. The index has been constructed in a way which means that you should be able to find the product you are searching for under multiple terms, depending what you choose to search for. For example, if you were looking for a Bench Grinder, you could find it under Bench > Grinders, or under Grinders > Bench.

Getting You What You Need

Can't find it? Just ask! Despite the size of this catalogue, it showcases just some 30 percent of Bishops product offering. Bishops is continually updating its range and inventory to meet customer's needs, while offering the latest in product innovations. If you cannot find a product that you require, please contact us at one of our warehouses. In all likelihood we will have it in our system and be able to quickly provide you with a quote. If we don't, our passionate staff are on hand to source it for you.

Ordering

Phone/Fax

To place an order or request a quote for a product listed in this catalogue, or any item that may not be listed, please call or fax your local Bishops branch.

Via Email

Send an email to sales@bishopbros.com.pg listing your requirements and region.

In-Store

All customers are welcome to order and collect goods from any Bishops store. Orders requesting delivery will incur a delivery/handling fee.

To assist with ordering/quotations, please supply the following information clearly:

- Account name
- Your name or contact person
- Contact phone, office, mobile, or email
- Bishops part numbers for products required
- Quantity of each part required
- Official company PO if a direct order

If you require any technical assistance in the part identification in the ordering/quotation process, please do not hesitate to contact a Bishops staff member.

Additional Copies of the Catalogue

Additional copies of the catalogue can be requested through your Bishops sales representative. A fee of K25 plus GST may be payable.

Catalogue Page Guide

All catalogues are different and we want you to be able to use ours with ease. Use this page as your cheat-sheet when navigating, reading and ordering from the catalogue.

Overview Of The Products On The Page

Section Number

Product Name

Product Specifications

Product's Variable Specifications

Manufacturer's Item Code

Denotes Product Is Non-Stock (If you see an * before a code in the Bishops Code column, this is the Manufacturer's Item Code. This is the code you should quote upon ordering.)

CUT RESISTANT GLOVES & SLEEVE, MECHANICS & LEATHER GLOVES

MAXICUT® ULTRA™ CUT D GLOVES

- CUTech™ technology for high cut-protection
- AIIRtech™ technology delivers 360° breathability
- Knitted synthetic liner
- Nitrile rubber coating on palm
- Micro-cup finish for optimised grip
- Reinforced area between thumb and forefinger
- Ergonomic shape to reduce fatigue
- 360° breathability
- Dermatologically accredited by the Skin Health Alliance
- Touchscreen compatible



Item Code	Size	Bishops Code	Item Code	Size	Bishops Code
44-4745-06	6 - XS	*44-4745-06	44-4745-10	10 - XL	*44-4745-10
44-4745-07	7 - S	*44-4745-07	44-4745-11	11 - 2XL	*44-4745-11
44-4745-08	8 - M	*44-4745-08	44-4745-12	12 - 3XL	*44-4745-12
44-4745-09	9 - L	*44-4745-09	-	-	-

* - SPECIAL ORDER: PLEASE QUOTE ITEM CODE UPON ORDERING THIS PRODUCT

MAXICUT® ULTRA™ CUT E GLOVES

- CUTech™ technology for high cut-protection
- AIIRtech™ technology delivers 360° breathability
- DURATech™ technology for outstanding durability
- Micro-cup finish for optimised grip
- Class leading form, fit and feel, reducing hand fatigue and increasing comfort
- Touchscreen compatible
- Dermatologically accredited by the Skin Health Alliance



Item Code	Size	Bishops Code	Item Code	Size	Bishops Code
44-5745-06	6 - XS	*44-5745-06	44-5745-10	10 - XL	*44-5745-10
44-5745-07	7 - S	*44-5745-07	44-5745-11	11 - 2XL	*44-5745-11
44-5745-08	8 - M	*44-5745-08	44-5745-12	12 - 3XL	*44-5745-12
44-5745-09	9 - L	*44-5745-09	-	-	-

* - SPECIAL ORDER: PLEASE QUOTE ITEM CODE UPON ORDERING THIS PRODUCT

TUFFSHIELD™ CUT 5 DYNEEMA ARM SLEEVE

- Provides additional forearm protection and comfort with cut level 5 resistance material, for protection when handling sharp objects
- Dyneema fibre offers good resistance to abrasion, tears and cuts
- Velcro strap to help sleeve remain in position
- Ergonomically designed for better fit and greater productivity
- One size



Length	Bishops Code
17(430mm)	55040000

MECHANICS GLOVES

7780

- Synthetic leather palm with PU reinforcement for amazing anti-slip and abrasion
- Stretchable and breathable spandex back
- Special designed neoprene strap for extreme comfort and fitting
- Neoprene cuff with velcro closure provides a snug fit
- Thumb crotch reinforced for extra wear
- Suitable for automotive, construction, mechanical and sports applications
- Conforms to EN388 3121 Standard
- Red/black



Size	Bishops Code	Size	Bishops Code
7 - S	55040262	10 - XL	55040265
8 - M	55040263	11 - 2XL	55040266
9 - L	55040264	12 - 3XL	55040267

MECHANICS GLOVES

7664

- Synthetic leather palm with silicon for excellent abrasion and grip
- Stretchable and breathable spandex back
- Soft neoprene cuff with velcro provide comfortable and flexible fitting
- Suitable for automotive, construction and mechanical applications
- Excellent grip in wet and dry applications
- Conforms to EN388 4121 Standard
- Orange/black



Size	Bishops Code	Size	Bishops Code
7 - S	55040271	10 - XL	55040274
8 - M	55040272	11 - 2XL	55040275
9 - L	55040273	12 - 3XL	55040276

CANDY STRIPE LEATHER GLOVES

- Economy chrome leather and cotton drill with knucklebar
- Multi-purpose, light duty
- Candy stripe
- One size



Item Code	Bishops Code
1201R	55040110

70

SAFETY EQUIPMENT & CONSUMABLES

Section Title

Bishops Item Code (use this when ordering)

Brand Logo

Product Image

Page Number

General Information

Bishops has made all reasonable efforts to ensure that details supplied in this catalogue are correct, and all product information has been prepared from supplier and manufacturers information provided.

Due to continual product developments from our suppliers, all details/specifications are subject to change without notice and should be confirmed at time of order. Some products may become unavailable or be replaced by alternate products of equivalent quality and specification.

To enable us to provide a product to suit your exact requirements or if you require a specific brand or model type, please specify at time of enquiry/ordering.

Quotations are supplied based on prevailing exchange rates, and any variation at time of supply will be charged to the client's account. All goods are quoted subject to prior sale, with quotations valid for seven days.

The placement of any order will be subject to the standard Trading Terms & Conditions of Bishop Brothers Engineering Ltd. Property in and title of the goods sold to the purchaser on invoice does not pass to the purchaser until goods are paid in full.

Full terms and conditions available on request or can be found at www.bishopbros.com.pg.

Payment Terms

Bishops accept cash, official company purchase orders, EFTPOS, Kundu, Visa, MasterCard (charges may apply). Please note cash on delivery is not accepted.

Customers can request to open a trading account with Bishops by calling **(+675) 325 2900** or email sales@bishopbros.com.pg.

Account terms and conditions are set out in the credit application form.

Returns & Warranties

For product returns, please contact your local Branch Manager for instructions. Proof of purchase will be required. Returns not accepted after 14 days. Returns may be liable to a 10% handling fee.

Many products sold by Bishops carry a manufacturer's warranty protecting against manufacturing defects. Bishops will fulfil its legal obligations in regards to warranty and work with customers and the manufacturer to resolve any legitimate warranty issues. Products misused, abused or affected by adverse power supply may not be covered under any manufacturer's warranty.















Please ensure you are familiar with the products operating manual prior to use.

MSDS

MSDS (Material Safety Data sheets) and other certification are prepared and supplied to Bishops by the actual manufacturer/supplier.

Bishops accept this information as accurate and cannot be held responsible for any inaccurate information provided.

Contents

Safety Equipment & Consumables	 01
Clothing & Footwear	 02
Welding & Abrasives	 03
Power, Pneumatic & Engine Powered Tools	 04
Hand & Cutting Tools	 05
Fasteners	 06
Material Handling & Lifting	 07
Workshop, Machinery & Construction Equipment	 08
General Industrial Products	 09
Janitorial, Hygiene, Crib & Leisure Products	 10
Lubricants, Sealants & Chemicals	 11
Hydraulic, Valves, Hoses & Fittings	 12
Bearings, Seals & Transmission Products	 13
Reference Charts & Information	 14
Index	 15



3M 2128
EN143-2000 P2 R
CE0088
3M W 228214
3M W 228214
AS / NZS 1716 P2
3M 2128

01 SAFETY EQUIPMENT & CONSUMABLES



HAND PROTECTION

General Purpose Gloves	2-4
Oil Resistant Gloves.....	4-5
Cut Resistant Gloves & Sleeves	5-7
Mechanics & Leather Palm Gloves.....	7-8
Riggers & Impact Gloves.....	8
Heat Protective Gloves.....	8
Glove Clips	8
Disposable & Rubber Gloves	10
Chemical Resistant Gloves.....	10-11
Welding Gloves.....	11

EYE PROTECTION

Safety Glasses & Accessories	13-15
Safety Goggles.....	16-17
Lens Cleaning Products.....	17
Face Shields & Visors.....	18

RESPIRATORY PROTECTION

Disposable Respirators.....	20
Reusable Respirators & Kits.....	21-22
Cartridges & Filters.....	22-23

HEARING PROTECTION

Earplugs	25
Earmuffs	26

HEAD PROTECTION

Hard Hats & Accessories.....	27
Bump Caps	27
Sun Hats.....	27

HEIGHT SAFETY

Body Harnesses & Kits.....	28-31
Lanyards & Anchorage.....	31-32
Rescue Kits.....	32
Self-Retracting Lifelines & Tool Lanyards.....	32-33

SKIN PROTECTION & FIRST AID

Sunscreen.....	33
First Aid Kits	33-34

SITE SAFETY

Emergency Eyewash & Safety Showers.....	35-37
Spill Control Absorbent Products.....	37-40
Spill Kits & Accessories	41-43
Contaminated Waste Disposal	42-43
Spill Bunds & Pallets & Covers	43-45
Fire Extinguishers, Hoses & Accessories.....	46-47
Lockout Padlocks	48-49
Lockout Kits & Hasps.....	49
Lockout Stations & Devices.....	50-52
Lockout & Safety Tags	52-53
SDS Storage	52
Safety & Traffic Signage	54-55
Worksite Safety, Barriers & Bunting.....	55-57
Anti-Slip & Reflective Tapes	57
Buggy Whips.....	58
Glow Sticks, Hazard Lighting & Auditory Warnings.....	58-59



PHOENIX GLOVES SELECTION CHART



Compare your favourite Phoenix gloves to select the correct glove for the job at hand.

Mechanical/Construction
 Level or Barrier Protection
 Strength & Durability
 Chemical Resistance
 Abrasion Resistance
 Tear Resistance
 High Visibility
 General Purpose
 Heat Protection
 Fit & Comfort
 Economical
 Oily Grip

	Mechanical/Construction	Level or Barrier Protection	Strength & Durability	Chemical Resistance	Abrasion Resistance	Tear Resistance	High Visibility	General Purpose	Heat Protection	Fit & Comfort	Economical	Oily Grip
			✓	✓				✓				
			✓	✓				✓				✓
				✓	✓	✓		✓				✓
	✓				✓	✓		✓				✓
	✓				✓	✓		✓				✓
	✓	✓	✓		✓	✓		✓	✓			✓
	✓	✓	✓		✓	✓		✓	✓			✓
	✓		✓		✓	✓		✓				
	✓	✓	✓		✓	✓		✓	✓			
	✓	✓	✓		✓	✓		✓	✓			✓
			✓			✓		✓				

COTTON GLOVES

- Hand-knitted cotton
- Most suitable for general use
- Elastic wrist for comfort
- One size fits most



Item Code	Bishops Code
2019	55040010

KNITTED POLKADOT GLOVES

- Knitted polycotton
- 7 gauge knit for higher strength and ventilation
- Comes with PVC dots for extra grip
- One size fits all



Item Code	Bishops Code
2009	55040030

KNITTED KEVLAR GLOVES

- PVC dots provide good grip
- Heat and cut resistant Kevlar
- One size fits most
- Yellow



Item Code	Bishops Code
9001D	55040060

RUBBER-COATED GLOVES

- Rough finish coating
- Wing-thumb and cotton-knitted lining
- Elastic band on the back and a rubberised cuff
- Complies to standard CE EN388
- Natural colour



Length	Bishops Code
254mm	55040620
280mm	55040621

EN388

PROTECTIVE GLOVES AGAINST MECHANICAL RISKS

AS/NZS 2161.3 adopts the European safety standard for protective gloves against mechanical risks – EN388, designed to assess the performance of a glove and its fabric/layers. In 2016, EN388 undertook some important changes, ensuring it kept up with technology and materials that have dramatically improved over the years. The updated standard includes two new tests – TDM-100 Cut and Impact.

Look for the pictogram below on gloves to determine the best fit for purpose hand protection. The pictogram should only be used if the glove meets at least level 1 or level A for at least one of the EN388 protective categories. You may see an X used instead of a number where a glove has not met a performance level of at least 1 or has no impact protection. An X will also be used to note blade cut resistance where a superior cut rating (ISO cut resistance) has been achieved.

	ABRASION RESISTANCE 	CUT RESISTANCE (COUPE TEST) 	TEAR RESISTANCE 	PUNCTURE RESISTANCE 	CUT RESISTANCE (TDM) 	IMPACT PROTECTION
ABCDEF	1: 100 2: 500 3: 2,000 4: 8,000	1: 1.2 2: 2.5 3: 5.0 4: 10.0 5: 20.0	1: 10 2: 25 3: 50 4: 75	1: 20 2: 60 3: 100 4: 150	A: 2 B: 5 C: 10 D: 15 E: 22 F: 30	P: PASSED F: FAILED X: NOT TESTED



Abrasion Resistance

A glove's Abrasion Resistance refers to how many times it can withstand abrasive pressure from sandpaper. Measured in revolutions, gloves must last a minimum of 100 revolutions to meet the minimum standard. Abrasion resistance is especially important for handling rough materials such as bricks.

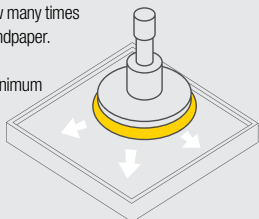

Cut Resistance (Coupe Test)

The Coupe Test is completed with a specific weight (5N) and a circular blade that will run back and forth until it cuts through the glove. The Coupe test is rated from 1 – 5. Gloves that test beyond Level 3 or produce a false Coupe Test reading will receive an "X", and the ISO Cut Test will provide the glove cut level.

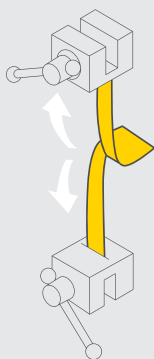
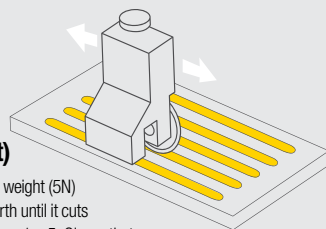

TEAR Resistance

Tear Resistance is measured in Newtons with a tensile strength machine, using pre-cut palm material from four glove samples. The material is fitted into the jaws of the machine, with the tear resistance being measured as the jaws move apart at a constant rate of speed (100mm/min).



Puncture Resistance

Puncture resistance is measured using a rounded stylus – similar to a roofing nail, not a needle. This is pushed 50mm at a consistent speed of 100mm/min by a compression test machine.

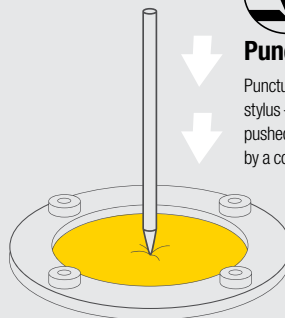

Cut Resistance (TDM)

The ISO Cut Resistance test is performed with a straight blade that runs over a piece of material once, similar to if a Stanley knife ran over a piece of material. The key difference is the varied pressure that is applied, with the lowest level of pressure being 2 Newtons (204g) up to 30 Newtons (3,059g). The ISO Cut Resistance is rated A (Lowest) – F (Highest).

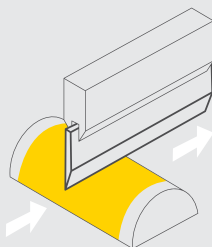

Impact Protection

The Impact test is a new addition to the EN388 standard, focussed on back of hand impact protection. To test, the glove is struck with 2.5kg at an impact energy of 5J. To pass the glove must transmit a maximum force of 7.0kN. This test is either a Pass (P) or Fail.

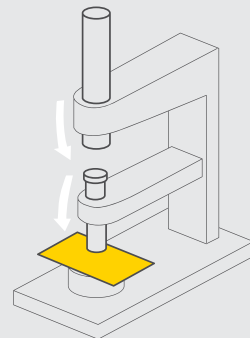

GENERAL PURPOSE & OIL-RESISTANT GLOVES

HELIO 101 GENERAL PURPOSE NITRILE COATED GLOVES



- 15 gauge breathable, lightweight nylon/spandex liner
- Foam nitrile palm coating
- Light, dexterous and comfortable
- High abrasion resistance
- Suitable for wet, dry or oily applications
- Knitted stretch cuff



Item Code	Size	Cuff Colour	Bishops Code
HELIO101GY07	7 – S	Red	55040870
HELIO 101GY08	8 – M	Yellow	55040872
HELIO 101GY09	9 – L	Brown	55040874
HELIO 101GY10	10 – XL	Black	55040876
HELIO 101GY11	11 – 2XL	Blue	55040878

MAXIFLEX® ELITE™ GENERAL PURPOSE GLOVES



- DURatech® technology for outstanding durability
- 30% thinner than traditional foam nitrile gloves
- AIRtech® technology delivers 360° breathability
- Optimised grip
- Class leading form, fit and feel, reducing hand fatigue and increasing comfort
- Touchscreen compatible



Item Code	Size	Bishops Code	Item Code	Size	Bishops Code
34-274-06	6 – XS	*34-274-06	34-274-09	9 – L	*34-274-06
34-274-07	7 – S	*34-274-07	34-274-10	10 – XL	*34-274-07
34-274-08	8 – M	*34-274-08	34-274-11	11 – 2XL	*34-274-08

* – SPECIAL ORDER: PLEASE QUOTE ITEM CODE UPON ORDERING THIS PRODUCT

MAXIFLEX® ULTIMATE™ WITH AD-APT® GENERAL PURPOSE GLOVES



- DURatech® technology for outstanding durability of more than 18,000 abrasive cycles
- AIRtech® technology delivers 360° breathability
- AD-APT® technology keeps hands cool
- Optimised grip delivered through a micro-cup finish
- Class leading form, fit and feel, reducing hand fatigue and increasing comfort
- Touchscreen compatible
- Also available in non-vending packs



Item Code	Size	Bishops Code	Item Code	Size	Bishops Code
42-874-06V	6 – XS	*42-874-06V	42-874-10V	10 – XL	55040346
42-874-07V	7 – S	55040343	42-874-11V	11 – 2XL	55040347
42-874-08V	8 – M	55040344	42-874-12V	12 – 3XL	*42-874-12V
42-874-09V	9 – L	55040345	–	–	–

* – SPECIAL ORDER: PLEASE QUOTE ITEM CODE UPON ORDERING THIS PRODUCT

MAXIFLEX® ULTIMATE™ WITH AD-APT® HI-VIS GLOVES



- DURatech® technology for outstanding durability of more than 18,000 abrasive cycles
- AIRtech® technology delivers 360° breathability
- AD-APT® technology keeps hands cool
- Optimised grip delivered through a micro-cup finish
- Class leading form, fit and feel, reducing hand fatigue and increasing comfort
- Touchscreen compatible
- Also available in vending packs
- Hi-vis yellow



Item Code	Size	Bishops Code	Item Code	Size	Bishops Code
42-874FY-06	6 – XS	*42-874FY-06	42-874FY-10	10 – XL	*42-874FY-10
42-874FY-07	7 – S	*42-874FY-07	42-874FY-11	11 – 2XL	*42-874FY-11
42-874FY-08	8 – M	*42-874FY-08	42-874FY-12	12 – 3XL	*42-874FY-12
42-874FY-09	9 – L	*42-874FY-09	–	–	–

* – SPECIAL ORDER: PLEASE QUOTE ITEM CODE UPON ORDERING THIS PRODUCT

MAXIDRY® OILY/WET PURPOSE GLOVES



- LIQUtech® for increased resistance to oils
- Excellent comfort through a synthetic coating combined with an industry leading super light seamless knit liner
- Micro-cup non-slip grip finish allows for a controlled grip in oily and wet applications
- Class leading form, fit and feel, reducing hand fatigue and increasing comfort
- Silicone-free
- Length: 250mm



Item Code	Size	Bishops Code	Item Code	Size	Bishops Code
56-427-07	7 – S	*56-427-07	56-427-10	10 – XL	*56-427-10
56-427-08	8 – M	*56-427-08	56-427-11	11 – 2XL	*56-427-11
56-427-09	9 – L	*56-427-09	–	–	–

* – SPECIAL ORDER: PLEASE QUOTE ITEM CODE UPON ORDERING THIS PRODUCT

MAXIDRY® ¾ DIPPED OILY/WET PURPOSE GLOVES



- LIQUtech® for increased resistance to oils
- Excellent comfort through a synthetic coating combined with an industry leading super light seamless knit liner
- Micro-cup non-slip grip finish allows for a controlled grip in oily and wet applications
- Class leading form, fit and feel, reducing hand fatigue and increasing comfort



Item Code	Size	Bishops Code	Item Code	Size	Bishops Code
56-425-07	7 – S	*56-425-07	56-425-10	10 – XL	*56-425-10
56-425-08	8 – M	*56-425-08	56-425-11	11 – 2XL	*56-425-11
56-425-09	9 – L	*56-425-09	–	–	–

* – SPECIAL ORDER: PLEASE QUOTE ITEM CODE UPON ORDERING THIS PRODUCT

MAXIDRY® TYPE C GAUNTLET GLOVES

- Liquid proof with increased resistance to oils via LIQUITech® technology
- Excellent comfort through a synthetic coating combined with an industry leading super light seamless knit liner
- Micro-cup non-slip grip finish allows for a controlled grip in oily and wet applications
- Class leading form, fit and feel, reducing hand fatigue and increasing comfort
- Length: 260mm



Item Code	Size	Bishops Code	Item Code	Size	Bishops Code
56-426-07V	7 – S	*56-426-07V	56-426-10V	10 – XL	*56-426-10V
56-426-08V	8 – M	*56-426-08V	56-426-11V	11 – 2XL	*56-426-11V
56-426-09V	9 – L	*56-426-09V	-	-	-

* – SPECIAL ORDER: PLEASE QUOTE ITEM CODE UPON ORDERING THIS PRODUCT

MAXIFLEX® CUT™ CUT 3B GLOVES

- DURatech® technology for outstanding durability
- AIRtech® technology delivers 360° breathability
- CUTtech® technology for medium cut-protection (EN-Cut Level 3B)
- Class leading form, fit and feel, reducing hand fatigue and increasing comfort
- Touchscreen compatible
- Also available in hi-vis yellow
- Non-venting packs available



Item Code	Size	Bishops Code	Item Code	Size	Bishops Code
34-8743-06V	6 – XS	*34-8743-06V	34-8743-10V	10 – XL	55040376
34-8743-07V	7 – S	55040370	34-8743-11V	11 – 2XL	55040378
34-8743-08V	8 – M	55040372	34-8743-12V	12 – 3XL	*34-8743-12V
34-8743-09V	9 – L	55040374	-	-	-

* – SPECIAL ORDER: PLEASE QUOTE ITEM CODE UPON ORDERING THIS PRODUCT

MAXIDEX® HYBRID GLOVES

- Full NBR coating
- LIQUITech® technology provides a liquid-proof barrier
- ViroSan™ virucidal coating destroys or inactivates viruses on glove surface to prevent the spread of viruses
- AD-APT® cooling technology releases a natural cooling agent to keep hands cool and dry during use
- Second skin fit conforms to the hand to maximise flexibility
- Touch screen compatible
- Washable at 40°C up to 3 times
- Palm thickness: 0.7mm
- Length: 240mm



Item Code	Size	Bishops Code	Item Code	Size	Bishops Code
19-007-06	6 – XS	*19-007-06	19-007-09	9 – L	*19-007-09
19-007-07	7 – S	*19-007-07	19-007-10	10 – XL	*19-007-10
19-007-08	8 – M	*19-007-08	19-007-11	11 – 2XL	*19-007-11

* – SPECIAL ORDER: PLEASE QUOTE ITEM CODE UPON ORDERING THIS PRODUCT

MAXIFLEX® CUT™ CUT 3B ¾ DIP DOTTED PALM GLOVES

- DURatech® technology for outstanding durability
- AIRtech® technology delivers 360° breathability
- CUTtech® technology for medium cut-protection (EN-Cut Level 3B)
- Class leading form, fit and feel, reducing hand fatigue and increasing comfort
- Touchscreen compatible



Item Code	Size	Bishops Code	Item Code	Size	Bishops Code
34-8453-06	6 – XS	*34-8453-06	34-8453-10	10 – XL	*34-8453-10
34-8453-07	7 – S	*34-8453-07	34-8453-11	11 – 2XL	*34-8453-11
34-8453-08	8 – M	*34-8453-08	34-8453-12	12 – 3XL	*34-8453-12
34-8453-09	9 – L	*34-8453-09	-	-	-

* – SPECIAL ORDER: PLEASE QUOTE ITEM CODE UPON ORDERING THIS PRODUCT

CORE BXN CUT B GENERAL PURPOSE GLOVES

- 18 Gauge HPPE liner
- Breathable micro-foam sandy nitrile palm coating
- Thumb crotch reinforcement (TCR) offers extra protection in high abrasion area
- Knitted stretch cuff
- Super dexterity and tactility
- Breathable and comfortable to wear
- Certified to LIC. NO: BMP 754503



Item Code	Size	Bishops Code
BXNG07	7 – S	55041002
BXNG08	8 – M	55041003
BXNG09	9 – L	55041004
BXNG010	10 – XL	55041005
BXNG011	11 – 2XL	55041006

MAXICUT® OIL™ CUT 3B ¾ DIP GLOVES

- LIQUITech® for increased resistance to oils
- Excellent comfort through a synthetic coating combined with a high performance cut protection liner (EN Cut Level 3B)
- CUTtech® technology
- Micro-cup non-slip grip finish allows for a controlled grip in oily and wet applications
- Dermatologically accredited
- Silicone-free



Item Code	Size	Bishops Code	Item Code	Size	Bishops Code
34-305-06P	6 – XS	*34-305-06P	34-305-09P	9 – L	*34-305-09P
34-305-07P	7 – S	*34-305-07P	34-305-10P	10 – XL	*34-305-10P
34-305-08P	8 – M	*34-305-08P	34-305-11P	11 – 2XL	*34-305-11P

* – SPECIAL ORDER: PLEASE QUOTE ITEM CODE UPON ORDERING THIS PRODUCT



CUT RESISTANT GLOVES

SAFETY EQUIPMENT & CONSUMABLES

MAXIFLEX® CUT™ CUT 3B HI-VIS GLOVES



- DURatech® technology for outstanding durability
- AIRtech® technology delivers 360° breathability
- CUTtech® technology for medium cut-protection (EN-Cut Level 3B)
- Class leading form, fit and feel, reducing hand fatigue and increasing comfort
- Touchscreen compatible
- Hi-vis yellow



Item Code	Size	Bishops Code	Item Code	Size	Bishops Code
34-8743FY-08V	8 – M	*34-8743FY-08V	34-8743FY-10V	10 – XL	*34-8743FY-10V
34-8743FY-09V	9 – L	*34-8743FY-09V	34-8743FY-11V	11 – 2XL	*34-8743FY-11V

* – SPECIAL ORDER: PLEASE QUOTE ITEM CODE UPON ORDERING THIS PRODUCT

CORE CXN CUT C GLOVES NITRILE COATED



- 15 gauge HPPE liner
- Cut resistant gloves
- Breathable micro-foam sandy nitrile palm coating
- Thumb crotch reinforcement (TCR) offers extra protection in high abrasion area
- Knitted stretch cuff
- Highly dexterous, tactile and comfortable
- Australian standard certified
- High resistance to abrasion and excellent grip in wet, dry or oily conditions
- Palm Dip – Blue/Black

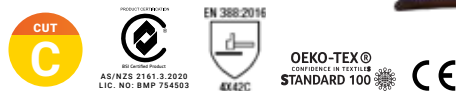

Item Code	Size	Bishops Code	Item Code	Size	Bishops Code
CXNBB07	7 – S	55041022	CXNBB10	10 – XL	55041025
CXNBB08	8 – M	55041023	CXNBB11	11 – 2XL	55041026
CXNBB09	9 – L	55041024	CXNBB12	12 – 3XL	55041027

MAXICUT® ULTRA™ CUT 4C GLOVES



- DURatech® technology for outstanding durability
- AIRtech® technology delivers 360° breathability
- CUTtech® technology for high cut-protection
- Optimised grip delivered through a micro-cup finish allows for a controlled grip
- Touchscreen compatible
- Supplied in vending-ready packaging
- Non-vending packs available



Item Code	Size	Bishops Code	Item Code	Size	Bishops Code
44-3745-06V	6 – XS	*44-3745-06V	44-3745-10V	10 – XL	*44-3745-10V
44-3745-07V	7 – S	*44-3745-07V	44-3745-11V	11 – 2XL	*44-3745-11V
44-3745-08V	8 – M	*44-3745-08V	44-3745-12V	12 – 3XL	*44-3745-12V
44-3745-09V	9 – L	*44-3745-09V	–	–	–

* – SPECIAL ORDER: PLEASE QUOTE ITEM CODE UPON ORDERING THIS PRODUCT

MAXICUT® ULTRA™ CUT 4C EXTENDED CUFF GLOVES



- DURatech® technology for outstanding durability
- AIRtech® technology delivers 360° breathability
- CUTtech® technology for high cut-protection
- Optimised grip delivered through a micro-cup finish allows for a controlled grip
- Touchscreen compatible
- Length: 300mm



Item Code	Size	Bishops Code	Item Code	Size	Bishops Code
44-3745-30-06	6 – XS	*44-3745-30-06	44-3745-30-10	10 – XL	*44-3745-30-10
44-3745-30-07	7 – S	*44-3745-30-07	44-3745-30-11	11 – 2XL	*44-3745-30-11
44-3745-30-08	8 – M	*44-3745-30-08	44-3745-30-12	12 – 3XL	*44-3745-30-12
44-3745-30-09	9 – L	*44-3745-30-09	–	–	–

* – SPECIAL ORDER: PLEASE QUOTE ITEM CODE UPON ORDERING THIS PRODUCT

MAXICUT® ULTRA™ DT™ CUT 4C 3/4 DOTTED PALM GLOVES



- DURatech® technology for outstanding durability
- AIRtech® technology delivers 360° breathability
- CUTtech® technology for high cut-protection
- Optimised grip delivered through a micro-cup finish allows for a controlled grip
- Dotted version for extra cushioning
- Touchscreen compatible



Item Code	Size	Bishops Code	Item Code	Size	Bishops Code
44-3455-06	6 – XS	*44-3455-06	44-3455-10	10 – XL	*44-3455-10
44-3455-07	7 – S	*44-3455-07	44-3455-11	11 – 2XL	*44-3455-11
44-3455-08	8 – M	*44-3455-08	44-3455-12	12 – 3XL	*44-3455-12
44-3455-09	9 – L	*44-3455-09	–	–	–

* – SPECIAL ORDER: PLEASE QUOTE ITEM CODE UPON ORDERING THIS PRODUCT

MAXICUT® ULTRA™ CUT 4C HI-VIS GLOVES



- DURatech® technology for outstanding durability
- AIRtech® technology delivers 360° breathability
- CUTtech® technology for high cut-protection
- Optimised grip delivered through a micro-cup finish allows for a controlled grip
- Touchscreen compatible
- Also available in vending packs
- Hi-vis yellow



Item Code	Size	Bishops Code	Item Code	Size	Bishops Code
44-3745FY-06	6 – XS	*44-3745FY-06	44-3745FY-10	10 – XL	*44-3745FY-10
44-3745FY-07	7 – S	*44-3745FY-07	44-3745FY-11	11 – 2XL	*44-3745FY-11
44-3745FY-08	8 – M	*44-3745FY-08	44-3745FY-12	12 – 3XL	*44-3745FY-12
44-3745FY-09	9 – L	*44-3745FY-09	–	–	–

* – SPECIAL ORDER: PLEASE QUOTE ITEM CODE UPON ORDERING THIS PRODUCT

MAXICUT® ULTRA™ CUT D GLOVES

- CUTech® technology for high cut-protection
- AIRtech® technology delivers 360° breathability
- Knitted synthetic liner
- Nitrile rubber coating on palm
- Micro-cup finish for optimised grip
- Reinforced area between thumb and forefinger
- Ergonomic shape to reduce fatigue
- 360° breathability
- Dermatologically accredited by the Skin Health Alliance
- Touchscreen compatible



Item Code	Size	Bishops Code	Item Code	Size	Bishops Code
44-4745-06	6 – XS	*44-4745-06	44-4745-10	10 – XL	*44-4745-10
44-4745-07	7 – S	*44-4745-07	44-4745-11	11 – 2XL	*44-4745-11
44-4745-08	8 – M	*44-4745-08	44-4745-12	12 – 3XL	*44-4745-12
44-4745-09	9 – L	*44-4745-09	–	–	–

* – SPECIAL ORDER: PLEASE QUOTE ITEM CODE UPON ORDERING THIS PRODUCT

MAXICUT® ULTRA™ CUT E GLOVES

- CUTech® technology for high cut-protection
- AIRtech® technology delivers 360° breathability
- DURAtch® technology for outstanding durability
- Micro-cup finish for optimised grip
- Class leading form, fit and feel, reducing hand fatigue and increasing comfort
- Touchscreen compatible
- Dermatologically accredited by the Skin Health Alliance



Item Code	Size	Bishops Code	Item Code	Size	Bishops Code
44-5745-06	6 – XS	*44-5745-06	44-5745-10	10 – XL	*44-5745-10
44-5745-07	7 – S	*44-5745-07	44-5745-11	11 – 2XL	*44-5745-11
44-5745-08	8 – M	*44-5745-08	44-5745-12	12 – 3XL	*44-5745-12
44-5745-09	9 – L	*44-5745-09	–	–	–

* – SPECIAL ORDER: PLEASE QUOTE ITEM CODE UPON ORDERING THIS PRODUCT

TUFFSHIELD™ CUT 5 DYNEEMA ARM SLEEVE

- Provides additional forearm protection and comfort with cut level 5 resistance material, for protection when handling sharp objects
- Dyneema fibre offers good resistance to abrasion, tears and cuts
- Velcro strap to help sleeve remain in position
- Ergonomically designed for better fit and greater productivity
- One size



Length	Bishops Code
17"(430mm)	55040000

MECHANICS GLOVES

7780

- Synthetic leather palm with PU reinforcement for amazing anti-slip and abrasion
- Stretchable and breathable spandex back
- Special designed neoprene strap for extreme comfort and fitting
- Neoprene cuff with velcro closure provides a snug fit
- Thumb crotch reinforced for extra wear
- Suitable for automotive, construction, mechanical and sports applications
- Conforms to EN388 3121 Standard
- Red/black



Size	Bishops Code	Size	Bishops Code
7 – S	55040262	10 – XL	55040265
8 – M	55040263	11 – 2XL	55040266
9 – L	55040264	12 – 3XL	55040267

MECHANICS GLOVES

7664

- Synthetic leather palm with silicon for excellent abrasion and grip
- Stretchable and breathable spandex back
- Soft neoprene cuff with velcro provide comfortable and flexible fitting
- Suitable for automotive, construction and mechanical applications
- Excellent grip in wet and dry applications
- Conforms to EN388 4121 Standard
- Orange/black



Size	Bishops Code	Size	Bishops Code
7 – S	55040271	10 – XL	55040274
8 – M	55040272	11 – 2XL	55040275
9 – L	55040273	12 – 3XL	55040276

CANDY STRIPE LEATHER GLOVES

- Economy chrome leather and cotton drill with knucklebar
- Multi-purpose, light duty
- Candy stripe
- One size



Item Code	Bishops Code
1201R	55040110



LEATHER, RIGGERS, IMPACT & THERMAL GLOVES & GLOVE CLIPS

SAFETY EQUIPMENT & CONSUMABLES

REFLECTIVE SHORT PALM LEATHER GLOVES

- Leather palm with hi-vis orange back
- Reflective strip on back for extra visibility
- One size



Item Code	Bishops Code
RF1201RED	55040115

RODEO RIGGERS GLOVES

- Made from quality cow split leather
- Elastic, snug-fit design
- Yellow
- Length: 254mm



Size	Bishops Code
9 - L	55040710

RIGGERS GLOVES

7623

- Synthetic leather palm for maximum strength and durability
- Hi-vis Spandex provides extra protection
- Neoprene strap for knuckle protection as well as comfort
- Open cuff for quick and easy fit
- Suitable for automotive, construction, rigging and mechanical applications
- Hi-vis yellow/black



Size	Bishops Code	Size	Bishops Code
7 - S	55040301	10 - XL	55040305
8 - M	55040302	11 - 2XL	55040306
9 - L	55040304	12 - 3XL	55040307

OIL RIGGERS GLOVES

7988

- Ideal for many industrial applications, such as oil and gas, mining, automotive, construction, rigging, farming, mechanical, electrical and plumbing
- Palm is double synthetic leather making them mould proof
- Fourchette areas are synthetic leather
- Back of the glove is hi-vis spandex that is breathable and comfortable
- Kevlar thumb crotch
- Long neoprene cuff with synthetic pull-tab provides extreme comfort and flexibility
- The sewn TPR fingers enhance the durability and protects hands and knuckles against bumps and bruises
- Curved fingers add dexterity and reduce hand fatigue
- Excellent grip in both wet and dry applications



Size	Bishops Code	Size	Bishops Code
7 - S	55040280	10 - XL	55040283
8 - M	55040281	11 - 2XL	55040284
9 - L	55040282	12 - 3XL	55040285

MAXIDRY® ZERO™ THERMAL GLOVES

- LIQUitech® for increased resistance to oils, grease and water
- THERMtech® offers thermal resistance inside
- Coating and seamless knitting technologies impart thermal insulation properties to resist cold
- Super soft and super flexible coating provides ultimate flexibility even in extremely cold environments
- Food certified according to the European Standard
- Compliant to FDA 21CFR177



Item Code	Size	Bishops Code	Item Code	Size	Bishops Code
56-451-07	7 - S	*56-451-07	56-451-10	10 - XL	*56-451-10
56-451-08	8 - M	*56-451-08	56-451-11	11 - 2XL	*56-451-11
56-451-09	9 - L	*56-451-09	-	-	-

* - SPECIAL ORDER: PLEASE QUOTE ITEM CODE UPON ORDERING THIS PRODUCT

GLOVE GRABBA

- A more compact two-piece design
- Keeps gloves handy while you work
- Quick release for emergency situations
- Securely holds gloves of most sizes



Item Code	Bishops Code
GG2IPOR50	55095910

A Flammability Resistance (1-4)

Gloves designed for high-heat exposure must be tested using a vertical flame test. This test measures the ability of the material to extinguish itself after being ignited.

After-Burn Time (seconds)	After-Glow Time (seconds)	Rating
Under 20 seconds	Infinity	1
Under 10 seconds	Under 120 seconds	2
Under 3 seconds	Under 25 seconds	3
Under 2 seconds	Under 5 seconds	4

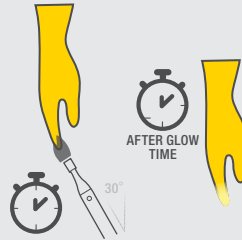

B Contact Heat Resistance (1-4)

Thermal protection from contact heat is determined by measuring a temperature rise of 10°C on the inside of the glove. When the Contact Heat performance level reaches 3 or 4, the Burning Behaviour test must achieve a minimum level 3, otherwise the maximum rating for Contact Heat will be level 2.

Temp. After 15 Seconds (plate temp)	Rating
100°C	1
250°C	2
350°C	3
500°C	4

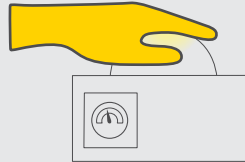

C Convective Heat Resistance (1-4)

Thermal protection from convective heat is determined by measuring the rate of temperature rise inside the glove when put in contact with a controlled gas flame. The convective heat test is used to measure a temperature rise of 24°C from the top of the cuff to the back of hand and palm. A level of performance in Convective Heat shall only be reported if a performance level 3 or 4 is obtained in the Flammability Test (Test 1).

Seconds	Rating
Under 4 seconds	1
Under 7 seconds	2
Under 10 seconds	3
Under 18 seconds	4

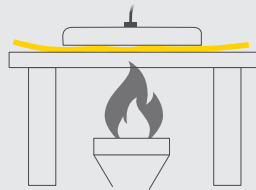

D Radiant Heat Resistance (1-4)

Thermal protection from Radiant Heat is determined by measuring a temperature rise of 24°C inside the glove when exposed to a defined heat source. The Radiant Heat test ensures the glove materials can resist high-heat through the back of the hand for a designated time period. The level of performance is only recorded if the glove achieves a minimum Level 3 in the Flammability Test.

Seconds	Rating
Under 5 seconds	1
Under 30 seconds	2
Under 90 seconds	3
Under 150 seconds	4

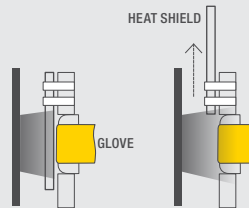

E Resistance to Small Splashes of Molten Metal (1-4)

Thermal Resistance to Small Drops of Molten Metal testing is measured by the number of molten metal drops that are required to heat the glove to 40° C inside the glove. This test measures the back and palm in a closed chamber where the lowest mean number after 4 tests is recorded. The level of performance is only recorded if the glove achieved a minimum Level 3 in the Flammability Test.

Number of Drops	Rating
Under 5	1
Under 15	2
Under 25	3
Under 35	4

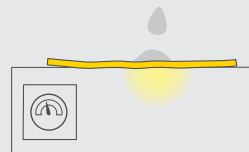

F Resistance to Large Quantities of Molten Metal (1-4)

Thermal Resistance to Large Quantities of Molten Metal testing is measured with a glove sample and PVC foil simulating human skin inside a glove. Molten metal is poured over the glove sample which sits over the PVC foil. After 3 tests the skin simulant is assessed and should not show any smoothness to the grained surface. The Thermal test is considered failed if steel droplets stick to the glove or if the glove ignites or is punctured.

Grams of Molten	Rating
30g	1
60g	2
120g	3
200g	4

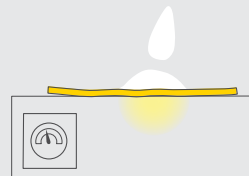

EN407 PROTECTION AGAINST THERMAL RISKS (HEAT & FIRE)

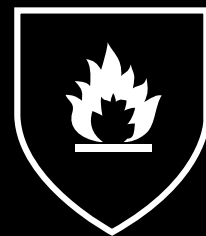

ABCDEF

The EN407 is a European standard designed to be used for any glove providing protection against thermal hazards. Heat proof gloves that have passed at least 1 of the 6 unique thermal hazard tests will be marked with the EN407 flame pictogram. If one or more of these numbers are replaced with an X or N/A this means that the glove has not been tested against that particular hazard.



DISPOSABLE, RUBBER & CHEMICAL RESISTANT GLOVES

SAFETY EQUIPMENT & CONSUMABLES

DISPOSABLE NITRILE EXAMINATION GLOVES

- Powder-free, close fitting
- TGA-listed for use in medical examination (ARTG108836)
- Industrial grade synthetic nitrile
- Chemical, abrasion and oil resistant
- Textured finger tips for extra grip
- 100 per box



Size	Bishops Code
Small	55040970
Medium	55040972
Large	55040974
X-Large	55040976

DISPOSABLE LATEX EXAMINATION GLOVES

- TGA-listed for use in medical examination (ARTG108836)
- Powdered for easy slip-on
- Superior comfort
- High level of flexibility and 'sensitive touch' for extra dexterity
- 100 per box



Size	Bishops Code
Medium	55040950
Large	55040955
X-Large	55040958
2X-Large	55040960

COATED PVC GLOVES

- Fully coated in red PVC
- Single-dipped
- High resistance to most acids



Length	Bishops Code
270mm	55040820
450mm	55040830

PVC CHEMICAL RESISTANT GLOVES

- Medium duty liquid repellent glove
- Interlock cotton liner
- PVC coating
- Knitted stretch cuff
- Anti-static
- Silicone-free
- Oil and grease resistant
- Length: 295mm



Item Code	Bishops Code
3001F	55040625

INDUSTRIAL RUBBER GLOVES

- Chemical and acid resistant
- Natural rubber, fully dipped
- Extra heavy duty
- Smooth finish and rolled cuff
- Complies to CE EN388
- Black



Length	Bishops Code
355mm	55040630
450mm	55040640

NCG330 NITRILE CHEMICAL RESISTANT GLOVES

- Full heavy duty nitrile gloves
- Anti-slip grip pattern on palm and fingers for better grip in wet and dry environments
- Extended cuff
- Provides good chemical resistance
- The penetration resistance has been assessed under laboratory conditions and relates only to the tested specimen
- Not tested against viruses
- Length: 330mm
- Green



Item Code	Size	Bishops Code	Item Code	Size	Bishops Code
NCG330/7	7 - S	55040900	NCG330/10	10 - XL	55040850
NCG330/8	8 - M	55040905	NCG330/11	11 - 2XL	55040855
NCG330/9	9 - L	55040845	-	-	-

MAXICHEM® NITRILE CHEMICAL GLOVES

- LIQUITech® chemical resistance
- Innovative TRITech™ Technology makes the glove 30% thinner and twice as comfortable
- Micro-cup non-slip grip finish allows for a controlled grip in wet applications
- Class leading form, fit and feel, reducing hand fatigue and increasing comfort
- Length: 350mm



Item Code	Size	Bishops Code	Item Code	Size	Bishops Code
76-830-07	7 - S	*76-830-07	76-830-10	10 - XL	*76-830-10
76-830-08	8 - M	*76-830-08	76-830-11	11 - 2XL	*76-830-11
76-830-09	9 - L	*76-830-09	-	-	-

* - SPECIAL ORDER: PLEASE QUOTE ITEM CODE UPON ORDERING THIS PRODUCT

MAXICHEM® LATEX CHEMICAL GLOVES



- LIQUitech® chemical resistance
- Innovative TRitech™ technology makes the glove 30% thinner and twice as comfortable
- Micro-cup non-slip grip finish allows for a controlled grip in wet applications
- Class leading form, fit and feel, reducing hand fatigue and increasing comfort
- Food approved (EU)
- Length: 350mm



Item Code	Size	Bishops Code	Item Code	Size	Bishops Code
76-730-07	7 – S	*76-730-07	76-730-10	10 – XL	*76-730-10
76-730-08	8 – M	*76-730-08	76-730-11	11 – 2XL	*76-730-11
76-730-09	9 – L	*76-730-09	–	–	–

* – SPECIAL ORDER: PLEASE QUOTE ITEM CODE UPON ORDERING THIS PRODUCT

MAXICHEM® CUT™ CUT 3B NITRILE CHEMICAL GLOVES



- LIQUitech® chemical resistance
- Innovative TRitech™ Technology makes the glove 30% thinner and twice as comfortable
- Micro-cup non-slip grip finish allows for a controlled grip in wet applications
- Class leading form, fit and feel, reducing hand fatigue and increasing comfort
- Length: 350mm



Item Code	Size	Bishops Code	Item Code	Size	Bishops Code
76-833-07	7 – S	*76-833-07	76-833-10	10 – XL	*76-833-10
76-833-08	8 – M	*76-833-08	76-833-11	11 – 2XL	*76-833-11
76-833-09	9 – L	*76-833-09	–	–	–

* – SPECIAL ORDER: PLEASE QUOTE ITEM CODE UPON ORDERING THIS PRODUCT

MAXICHEM® CUT™ CUT 3C LATEX CHEMICAL GLOVES



- LIQUitech® chemical resistance
- Innovative TRitech™ technology makes the glove 30% thinner and twice as comfortable
- Micro-cup non-slip grip finish allows for a controlled grip in wet applications
- Class leading form, fit and feel, reducing hand fatigue and increasing comfort
- Food approved (EU)
- Length: 350mm



Item Code	Size	Bishops Code	Item Code	Size	Bishops Code
76-733-07	7 – S	*76-733-07	76-733-10	10 – XL	*76-733-10
76-733-08	8 – M	*76-733-08	76-733-11	11 – 2XL	*76-733-11
76-733-09	9 – L	*76-733-09	–	–	–

* – SPECIAL ORDER: PLEASE QUOTE ITEM CODE UPON ORDERING THIS PRODUCT

WELDING GLOVES



- Full leather, reinforced double-palm
- Grey
- Length: 254mm
- One size
- Complies to standards EN388, EN420 and EN12477



Bishops Code
55040230

WELD SERIES GLOVES



- Premium quality blue cow split leather with gold Kevlar stitching to withstand high temperatures over extended periods of time
- Reinforced palm and thumb for added durability and protection
- Fully lined wear seams welted for extra strength
- Provides protection from welding spatter and dross heat
- Ideal for usage in welding and fabrication, metal castings, mining and construction
- Length: 406mm
- One size



Item Code	Bishops Code
BGW16	55040255

RED ARMOR WELDING GLOVES



- Full leather
- Reinforced thumb and double palm Kevlar
- Kevlar stitched in the optimum way to resist burning from sparks
- Suitable for all welding situations
- Red
- Length: 460mm



Bishops Code
55040240

BLUE BOMBERS WELDING GLOVES



- Cow split leather with Kevlar
- Fully lined with all wear seams welted for additional protection
- Provides protection from welding spatter and dross heat
- Blue
- Length: 406mm



Bishops Code
55040252



IMPORTANCE OF EYEWEAR

An estimated 60% of all eye injuries occur at work, which adds up to around 30,000 work related eye injuries every year in Australia. The vast majority of these eye injuries could be prevented by following proper safety procedures and wearing appropriate personal protective equipment.

Selecting correct protection

AS/NZS 1336:2014 stipulates that eye related hazards and risks must be assessed and evaluated before selecting eye protection for a particular task or area. When selecting the appropriate eye protection, consider the following:

- Any hazards and risks relating to the tasks at hand
- Any hazards and risks relating to the environment and location
- The visual requirements of the task
- The shape of the eyewear and how compatible it will be with other PPE
- Workers eyesight and whether they need to wear prescription glasses or contacts beneath their safety eyewear
- The wearer's preference in relation to style, fit and comfort



Major hazards



Lens Coatings

Lens coatings increase the durability of eye protection and provide versatility depending on the task at hand and the working environment. The most common coatings found in the market are anti-scratch and anti-fog, which are available in various combinations. These are the most common options:

- **Anti-scratch** on the inside and outside of the lens;
- **Anti-fog** on the inside and outside of the lens;
- **Anti-scratch on the outside** of the lens and **anti-fog on the inside** of the lens.

Anti-fog coatings are suitable for working in varying temperatures and/or areas of high humidity. It is important to address any fogging issues your workers may experience to avoid reduced visibility or the removal of safety glasses while working.

Anti-scratch coatings are suitable for dusty and dirty working environments. Small particles can have an abrasive effect on an uncoated lens, decreasing its transparency and longevity.

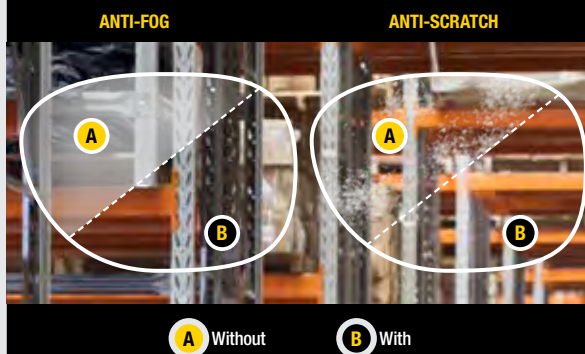

Lens Markings

Safety eyewear should be compliant with AS/NZS 1337.1 – Eye and face protectors for occupational applications and/or AS/NZS 1337.6 – Prescription eye protectors against low and medium impact. If a product is certified to one of these standards they will display the certifier's logo on the packaging.



SAI Global



BSI Benchmark



Global Mark

In addition to these logos, eyewear will have a number of markings to indicate the applications and environments it is suitable for, including impact rating and protection against specific hazards.

Test Type	Symbol	Applicable PPE
Medium Impact – 6mm ball travelling at 45m/sec	I or F	Safety glasses, goggles, some full face shields
High Impact – 6mm ball travelling at 120m/sec	V or B	Full face shields only
Extra high Impact – 6mm ball travelling at 190m/sec	A	Full face shields
Molten metal	M or 9	Face shields, wire mesh screens with plastic lenses
Splash	C or 3	Wide vision goggles with indirect ventilation
Dust	D or 4	Goggles with indirect ventilation
Gas	G or 5	Goggles without ventilation
Outdoor use	O	Safety spectacles, goggles and face shields
Sun glare	Category 0-3	Safety glasses
Transitional	Category 0-3	Safety glasses
High Temperature	H	Full face shields and goggles

The maximum impact rating safety glasses can achieve is Medium Impact; higher ratings can only be achieved when the face is protected by a full face shield.

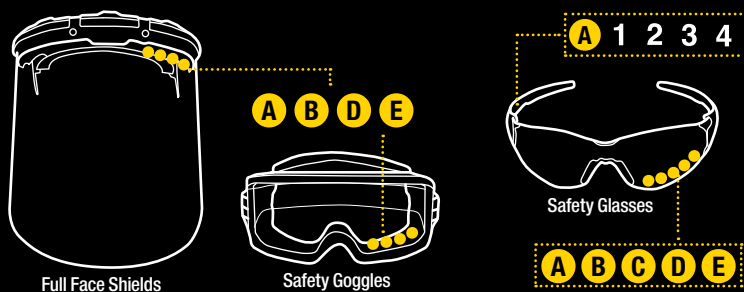

When selecting safety glasses, goggles or face shields keep an eye out for the markings on the lens and the side arms for information on the rating and standards that apply to that particular product.

- 1 Australian Standard No. (AS/NZS 1337.1:2010)
 - 2 License No.
 - 3 Manufacturer Product Code
 - 4 Certification Mark (this could be a number or symbol)
- A** Manufacturer Identification
 - B** Impact Resistance
 - C** Special Performance
 - D** Ocular Category
 - E** Symbol for Polarisation (optional)

ZERO SAFETY GLASSES

- Wraparound frameless design
- Solid nose bridge
- Solid wide arms for added protection
- Anti-scratch lens coating on both sides
- UV400 protection
- Certified AS/NZS 1337 for medium impact protection



Item Code	Lens Colour	Bishops Code
PPE-ZERO-C	Clear	55015042
PPE-ZERO-S	Smoke	55015242

SPERIAN A700 SAFETY SPECS

- The A700 provides value whilst combining sports styling with high protection and comfort
- Exceptional value, comfort and protection
- Universal nose bridge and soft temple tips for all-day comfort
- Fashionable sports styling and lightweight design
- 9 base wrap around lens provides close to the face protection
- Material: Polycarbonate
- Weight: 21.6g
- Medium impact protection
- Approvals: AS/NZS 1337, licence No: SMK 0797



Lens Colour	Bishops Code	Lens Colour	Bishops Code
Clear Anti-Fog	55015050	Brown Anti-Fog	55015352
Grey Anti-Fog	55015252	Clear Hard Coat	55015366
Blue Anti-Fog	55015254	Grey Hard Coat	55015367

LIGHTZ SAFETY GLASSES

- Wraparound frameless design
- Solid nose bridge
- Slim arms with soft temple pads
- Anti-scratch lens coating on both sides
- UV400 protection
- Certified AS/NZS 1337 for medium impact protection



Item Code	Lens Colour	Bishops Code
LIGHTZ-C	Clear	55015043
LIGHTZ-S	Smoke	55015243
LIGHTZ-SM	Smoke Mirror	55015253

CHILL™ GLOSS SPECS

- Flexible temples comfortably keep eyewear in place
- Comfort-moulded nosepiece fits most wearers without obscuring vision
- Available in a wide array of lens tints to meet the needs of most work environments
- Wrap-around 9-base curve lens offers a close fit with excellent side protection
- Anti-fog coating helps keep lenses clear in humid or extreme environments, and are available in clear and grey tints
- Lightweight and comfortable, weighs less than 25.2g

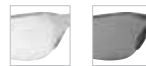

Lens Colour	Bishops Code
Silver Mirror Hardcoat	55015368
Clear Anti-Fog	55015369
TSR Grey Anti-Fog	55015370

IMPULSE METAL-FREE SAFETY GLASSES

- Stylish frameless design
- Solid nose bridge
- Slim arms with soft temple pads
- 9C base curve lens
- Polycarbonate lens
- Anti-fog and anti-scratch coating
- Mining and food safe with no metal parts
- Certified AS/NZS 1337 for medium impact protection
- UV400 protection



Item Code	Lens Colour	Bishops Code
IMPULSE-C	Clear	55015082
IMPULSE-S	Smoke	55015282

PROPEL SAFETY GLASSES



- Frameless
- Soft nose bridge
- Dual composite, soft-liner arms
- Anti-fog lens coating on both sides
- Light mirror lens tint
- Optional quick-release headband and vented gasket sold separately
- Certified AS/NZS 1337 for medium impact protection



Item Code	Lens Colour	Bishops Code
PPE-PROPEL-A	Clear Mirror	55015066



SAFETY GLASSES

SAFETY EQUIPMENT & CONSUMABLES

REACHER SAFETY GLASSES



- Wraparound frameless design
- Non-slip flexible nose bridge
- Wide arms with soft flexible grip
- 9C base curve lens
- Anti-fog and anti-scratch coating on both sides
- Mining and food safe with no metal parts
- Certified AS/NZS 1337 for medium impact protection
- UV400 protection



Item Code	Lens Colour	Bishops Code
REACHER-C	Clear	55015084
REACHER-S	Smoke	55015284

REACHER+ METAL-FREE SAFETY GLASSES



- Wraparound frameless design
- Non-slip flexible nose bridge
- Wide arms with soft flexible grip
- 9C base curve lens
- Anti-scratch and superior anti-fog coating for high humidity environments
- Clear lens with coloured arms
- Mining and food safe with no metal parts
- Certified AS/NZS 1337 for medium impact protection
- UV400 protection



Item Code	Lens Colour	Bishops Code
REACHER+-C	Clear	55015085

CARBON SAFETY GLASSES



- Sporty lightweight frameless design
- Soft nose bridge
- Dual composite arms with soft temple pads
- Anti-fog lens coating on both sides
- Built-in brow guard
- UV400 protection
- Certified AS/NZS 1337 for medium impact protection



Item Code	Lens Colour	Bishops Code
CARBON-C	Clear	55015051
CARBON-S	Smoke	55015251
CARBON-A	Amber	55015351
CARBON-B	Brown	55015354

SPYDA SAFETY GLASSES



- Ultra-lightweight wraparound frameless design
- Spring nose-bridge for added comfort
- Wide arms for added protection
- Soft Airflex temple pads
- Low profile design suitable for use with earmuffs
- Anti-fog and anti-scratch coating on both sides
- 9C base curve lens
- Certified AS/NZS 1337 for medium impact protection
- UV400 protection



Item Code	Lens Colour	Bishops Code
SPYDA-C	Clear	55015081
SPYDA-S	Smoke	55015281

SPYDA SAFETY GLASSES WITH FOAM GASKET



- Ultra-lightweight wraparound frameless design
- Spring nose-bridge for added comfort
- Wide arms for added protection
- Soft Airflex temple pads
- 9C base curve lens
- Anti-fog and anti-scratch coating on both sides
- Smoke lens with colour-tipped arms
- Low profile design suitable for use with earmuffs
- Certified AS/NZS 1337 for medium impact protection
- UV400 protection
- Fitted with foam gasket



Item Code	Lens Colour	Bishops Code
55015082	Smoke	55015286

SPERIAN SP1000TM SEALED SPECS

- Highly adjustable flame resistant headband provides excellent fit
- Exceptional peripheral vision and coverage with wrap-around 8 base dual lens style
- Choose from the premium Durastreme™ (AF&HC) lens coating with standard anti-fog like below or choose hard coated lenses
- Durastreme™ models provide durable performance with minimised fogging thanks to top and bottom indirect ventilation and dual anti-fog/anti-scratch lenses
- Soft and flexible nose piece conforms to a variety of facial profiles and minimises slipping
- Soft high quality face cushioning and padded temple tips offer all day comfort
- AS/NZS 1337: 2010 medium impact, license number SMK 2209



Lens Colour	Bishops Code
Black/Grey	55015364

ZYNC POLARISED SAFETY GLASSES

- Full frame design
- Solid nose bridge
- Dual composite arms with soft temple pads
- Wide arms for added protection
- Anti-scratch coating on both sides
- Grey polarised lens and black frame
- Sporty wraparound style
- 99.99% UV protection
- Certified AS/NZS 1337 for medium impact protection



Item Code	Lens Colour	Bishops Code
ZYNC	Grey Polarised	55015249

SAFETY OVER-GLASSES SPECTACLES

- Polycarbonate frame
- Solid nose bridge
- Solid arms
- Anti-scratch lens coating on both sides
- Deep design allows the glasses to be worn over prescription spectacles
- 99.9% UV protection for outdoor wear



Lens Colour	Bishops Code
Clear	55015010
Smoke	55015015

BIFOCAL MAGNIFICATION SAFETY GLASSES

- Stylish frameless design
- Solid nose bridge
- Anti-fog lens coating on both sides
- Diopter lens with +1 to +3 magnification
- Lightweight wraparound design
- Clear lens
- UV400 Protection



Item Code	Magnification	Bishops Code
90080272	+1.00	55015400
90080273	+1.50	55015410
90080274	+2.00	55015420
90080275	+2.50	55015430
90080276	+3.00	55015440

SAFETY GLASSES STRAP

- Suits most safety glasses
- Comfortable and flexible neoprene
- Green



Item Code	Bishops Code
GSN-B	55015550

SAFETY GLASSES STRAP

- Made from poly cotton
- Allows glasses to be worn around neck in between use
- Prevents loss of glasses due to dropping



Item Code	Bishops Code
PPE-CORD	55015500

SAFETY GLASSES DUST GASKET

- Vented gasket to suit Propel safety glasses
- Glasses not included



Item Code	Bishops Code
1157F1	55015560

SAFETY GLASSES HEADBAND

- Quick-release headband to suit Propel safety glasses
- Glasses not included



Item Code	Bishops Code
1157-PI	55015562



SAFETY GOGGLES

SAFETY EQUIPMENT & CONSUMABLES

IMPACT SAFETY GOGGLES



- General purpose
- Fits over personal spectacles
- Ventilated for fog-free use
- Impact resistant
- Soft, flexible vinyl frame
- Lightweight, tough polycarbonate lens
- Complies to standard AS/NZS 1337:1992



Item Code	Lens Colour	Bishops Code
SE1120	Clear	55015710

PHENOS SAFETY GOGGLES



- PVC frame
- Indirect vent
- Approved for use against chemical splash
- Comfortable fit and secure foam seal
- Anti-fog and anti-scratch lens coatings
- Fits over most prescription glasses
- Adjustable strap
- Certified AS/NZS 1337 for medium impact protection
- UV400 protection



Item Code	Lens Colour	Bishops Code
PHENOS-C	Clear	55015711
PHENOS-S	Smoke	55015712

GALAXY SAFETY GOGGLES



- Closed cell foam lining
- Adjustable elasticated strap with quick-release buckle
- Unvented
- Anti-fog and anti-scratch coating on both sides
- Clear lens with black/grey frame
- Excellent dust protection
- Certified AS/NZS 1337 for medium impact protection



Item Code	Lens Colour	Bishops Code
PPE-GALAXY	Clear	55015727

RAPID SAFETY GOGGLES



- Full TPE frame
- Adjustable elasticated strap with quick-release buckle
- Unvented
- Anti-fog and anti-scratch coating on both sides
- Clear lens with orange/grey frame
- Excellent dust protection
- Ultra high UV protection
- Fits comfortably over prescription glasses and respiratory protective gear
- Certified AS/NZS 1337 for medium impact protection
- Replacement lens available separately



Item Code	Lens Colour	Bishops Code
PPE-RAPID	Clear	55015728

DURAMAXX® GOGGLES WITH FABRIC STRAP

- Modern low profile design for splash and impact protection
- Durastreme™ lens technology – anti-fog on the inside, anti-scratch on the outside adds up to three times more life to your lenses
- Elastomer body is lightweight, flexible and provides a comfortable contoured fit to different facial profiles
- Indirect ventilation system channels and directs air flow to minimise fogging and improve vision
- Pivoting and adjustable headband permits fast and easy fitting even when worn with hard hats
- Fits over most prescription eyewear
- Large panoramic field of vision
- Easily replaceable lenses
- Certified to AS/NZS 1337.1:2010



Item Code	Lens Colour	Bishops Code
1017738	Grey	55015732

CHEMICAL SPLASH GOGGLES



- Complies to standard ANSI Z87.1
- Fits over personal spectacles
- Indirect ventilation
- Soft, flexible vinyl frame
- Lightweight, tough polycarbonate lens
- Pliable nose bridge for comfort
- Anti-fog lens



Item Code	Lens Colour	Bishops Code
SE1113	Clear	55015722

CHEMICAL SPLASH GOGGLES

- Wide vision Indirect ventilation
- Flexible vinyl frame
- Lightweight tough polycarbonate lens
- Excellent protection against dust, splash and impact
- Anti-fog lens
- Complies to standard AS/NZS 1337:1992



Item Code	Lens Colour	Bishops Code
SE1128	Clear	55015725

CHEMICAL SPLASH GOGGLES

- Wide vision
- Adjustable head band
- Fitted with an indirect vent which allows airflow and reduces fog
- Are an excellent choice for general purpose applications
- Complies to standard ANSI Z87.1



Item Code	Lens Colour	Bishops Code
SE1122	Clear	55015726

CHEMICAL SPLASH GOGGLES

- Excellent protection against dust, splash and impact
- Fits over personal spectacles
- Fitted with indirect ventilation
- Flexible vinyl frame
- Has a lightweight, tough polycarbonate lens
- Complies to standard AS/NZS 1337:1992



Item Code	Lens	Bishops Code
SE1110	Clear	55015720
SE1111	Clear - Anti-Fog	55015721

ALCOHOL-FREE LENS CLEANING WIPES



- Safely and quickly cleans lenses
- Pre-moistened, non-abrasive lens towelette
- Specially formulated to clean and protect lens coating to ensure longevity
- Individually packaged towelettes
- Alcohol-free formula
- Anti-bacterial
- Towelette size: 152 x 127mm
- Box of 100



Item Code	Bishops Code
LCWAF-100	55015845

LENS CLEANING SPRAY

- Cleans spectacles and faceshields
- Anti-fog solution reduces fogging mist
- Safe for glass and plastic lenses
- 150g aerosol



Item Code	Bishops Code
220112	55015840

WALL MOUNTABLE LENS CLEANING STATION

- Convenient one-stop location for all lens cleaning needs
- All products specifically designed to care for uvex lens coatings
- Wall mountable (screws included)
- Refills available
- Also suitable to hold 100 pack uvex lens cleaning towelettes



Item Code	Bishops Code
1007	55015810

LENS CLEANING STATION

- Spectacle and faceshield lens cleaning station
 - Anti-fog solution reduces fogging mist
 - Wall mountable unit
- Includes:**
- 2 x Cans of lens cleaning spray
 - 1 x Pack of cleaning tissue



Item Code	Bishops Code
220111	55015820



FACE SHIELDS

BIONIC® COMPLETE FACE SHIELD WITH CHIN GUARD

- Fully adjustable head suspension
- Ideal for protection against flying debris and particles, liquids and vapours
- Sweatband is removable for easy washing and replacement
- ABS frame with clear, uncoated polycarbonate visor
- Locking mechanism for complete safety
- Licence No: SMK 2209
- Attaches quickly and easily to a variety of hard hats with adaptor (sold separately)
- High impact and splash protection certified to AS/NZS 1337



Weight	Bishops Code
360g	55020030

COMPLETE FACE SHIELD – CLEAR VISOR



- Comes with ABS brow guard which eliminates injury
- Fitted with aluminium-bound clear visor
- 203 x 381mm
- Complies to standard CE EN166



Item Code	Bishops Code
SE1760	55020010

COMPLETE FACE SHIELD – MESH VISOR



- Comes with ABS browguard which reduces the risk of injury
- Aluminium-bound metal wire-mesh visor provides protection against flying branches and wood chips for forestry operations
- Also provides heat resistance against molten metals
- 203 x 381mm
- Complies to standard CE EN1731



Item Code	Bishops Code
SE1740	55020015

CLEAR FACE SHIELD VISOR



- Aluminium-bound acetate screen
- Suits 55020010 face shield and 55020090 bracket
- Clips easily onto bracket
- 203 x 394mm
- Complies to standards ANSI Z87.1/CE and EN 166



Item Code	Bishops Code
SE173A	55020110

DARK FACE SHIELD VISOR



- Aluminium-bound acetate screen
- Suitable for gas welding, brazing and light cutting operations
- Suits 55020010 face shield and 55020090 bracket
- Clips easily onto bracket
- Shade No.5 green visor
- 203 x 394mm



Item Code	Bishops Code
SE174D #5	55020115

WIRE MESH SHIELD VISOR



- Aluminium-bound metal wire mesh
- Provides protection against flying branches and wood chips during forestry operations
- Also protects against molten metals and where deflection of extreme heat is required
- Suits 55020010 face shield and 55020090 bracket
- 203 x 394mm
- Complies to standard CE EN1731



Item Code	Bishops Code
SE175A	55020120

MOUNTED HELMET BRACKET



- Aluminium
- ABS construction
- Grooved frame with spring coil
- Easy to install on helmet and sturdy
- Positive stop hinge automatically holds visor in raised position
- Suits 55020010 face shield
- Certified to CE EN166
- Visor not included



Item Code	Bishops Code
SE174B	55020090

TYPES OF RESPIRATORS

Tight Fitting Negative Pressure Respirators

Disposable and regular half and full-face respirators are negative pressure, relying on the wearer to draw air through the filters using their own breath.



Disposable Respirator

Single use respirators that protect against dusts, mists and fumes. Suitable for use during activities such as sanding and drilling or to protect against bushfire smoke.



Half Face Respirator

Respirators that offer protection against particulates, gases and vapours. There are a variety of filter options available that provide protection for activities such as grinding, normal spray painting, and asbestos removal. Filter cartridges are reusable.



Full Face Respirator

Full face respirators that provide a higher level of protection against particulates, gases and vapours as well as highly toxic chemicals. The benefit of a full-face respirator is that they cover the eyes and much of the face, providing additional protection against liquid splashes and irritating vapours.

Positive Pressure Respirators



Powered Air Purifying Respirator (PAPR)

PAPR units are positive pressure meaning they utilise a battery-operated unit that propels air through the filters. PAPR units can include tight fitting half and full-face masks as well as a variety of head top options depending on the application. Loose head tops may be suitable for people with certain styles of facial hair who cannot achieve a Fit Test pass with a negative pressure tight-fitting respirator.

Air-Supplied Respirators

Positive pressure respirators that provides a supply of clean air, as opposed to filtering the air in the atmosphere. Air-supplied respirators are usually used in situations where the hazard potential is extremely high, such as:

- when atmospheric conditions are unknown;
- when there is immediate danger to life or health (IDLH);
- when hazards can't be mitigated by other respiratory protection;
- when the level of hazard in the workplace is unable to be properly assessed.



Self-Contained Breathing Apparatus (SCBA)

Utilises a cylinder of clean compressed air, carried by the user, which feeds a tight-fitting full-face mask.

This provides the highest level of respiratory protection and can be used for emergency response or rescue situations.

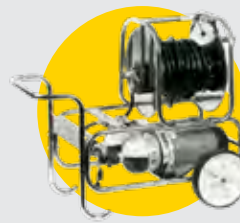

Compressed Airline

Utilising a source of clean air, such as a cylinder or compressor, an airline feeds breathable air to a hood or face piece, either tight or loose fitting.

Airline setups are generally used for applications like 2 pack spray painting.



Airline Escape

An emergency supply of air that allows for a safe exit from a hazardous situation such as a confined space.

P1 P2 P3 & Vapour Gas

When selecting respiratory protection products it is important to choose a respirator that will provide the appropriate level of protection for its intended environment.

Once you have completed an assessment of the specific risks in your working environment, understanding protection classifications will help you select the correct product to keep the user safe during exposure to harmful contaminants.

Particulate filters

Particulate filters are divided into three classes under the AS/NZS 1716 standards for use in Australia and New Zealand.



P1: Low efficiency filter for protection against mechanically generated particles, for example silica or wood dust. Suitable for use during activities like grinding, sanding, cutting, sawing and drilling.



P2: Medium efficiency filter for use against mechanically and thermally generated particles. Protects against sub-micron thermally generated particles, for example metal fumes, fertiliser and bushfire smoke, as well as bacteria and virus particles like those generated by COVID-19 and SARS.



P3: High efficiency filter used for protection against highly toxic or highly irritant mechanically or thermally generated particles, for example insecticides, radionuclides and beryllium. Particle filters can only receive a P3 classification when worn with a full face piece.

Vapour & Gas Filters

These filters are designed to protect against specific vapours and gases using absorbent material to filter the vapour or gas molecules. They are marked according to the vapours and/or gases they protect against, usually more than one, and are classed by absorbency.

- 1 – Low to medium absorption 2 – Medium absorption 3 – High absorption

Higher absorbency indicates a higher level of protection against harmful gas or vapour molecules. There are a number of markings on vapour and gas filters that indicate the specified protection, as shown in the table below.

Filters will be labelled with the specific protection and the level of that protection, as shown in the graphic below. E.g. K1 suggests a low to medium level of protection against ammonia. The filter shown protects against organic vapours (boiling points >65°C), Acid Gases, Sulphur Dioxide and Ammonia, all at Class 1 absorbency.

A – Organic vapours (boiling points > 65°C)
AX – Organic compounds (boiling point < 65°C)
B – Acid Gases
E – Sulphur Dioxide
Hg – Mercury
K – Ammonia
P2/P3 – Particulate

- A1**
- B2**
- E1**
- K1**

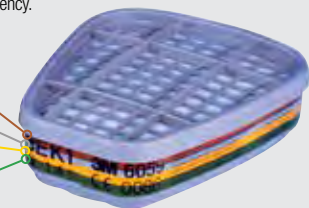

Combination filters are also available, which are designed to protect against particles, vapours and gases. Combination filters will also be marked to indicate the specific vapour/gas they protect against.



DISPOSABLE MASKS & RESPIRATORS

SAFETY EQUIPMENT & CONSUMABLES

DISPOSABLE SURGICAL MASKS

- Medical grade disposable face masks
- Elasticated ear loops
- Latex-free
- Protection level: 3, Type IR
- 50 per pack



Item Code	Bishops Code
SM-M101	55055005

PAPER DUST MASK

- Disposable and non-toxic
- Lightweight and designed with a contour fit for extra comfort
- 50 per box



Item Code	Bishops Code
	55055010

P2 KN95 FLAT FOLD RESPIRATORS

- Soft fibre construction for superb comfort and fit
- Low profile design allows for perfect fit with glasses or safety goggles
- Allows easy breathing and speaking
- Disposable and maintenance-free
- Dust and splash proof
- Anti-virus protection 95% filtration
- KN95 grade
- TGA Approved, ARTG Identifier: 344329
- 10 per pack



Item Code	Bishops Code
97019720	55055060

P1 CUP RESPIRATORS

- Pre-formed
- Exhalation valve to reduce heat build-up and improve life of mask
- Easily adjustable nose bridge band for maximum seal and versatile fit
- Wide ergonomic cup design
- Soft fibre construction
- Exhalation valve to reduce heat build-up and improve life of mask
- Twin bands for easy adjustment and wearer comfort
- Disposable and maintenance-free



55055040

Complies With:
• AS/NZS 1216: 2012



Item Code	Description	Pack Qty	Bishops Code
DMP1-20	P1 Cup Respirator	20	55055042
DMP1V-10	P1 Cup Respirator with Valve	10	55055040

P2 CUP RESPIRATORS



- Easily adjustable nose bridge band for maximum seal and versatile fit
 - Wide ergonomic cup design
 - Twin adjustable head bands for improved comfort
 - Soft fibre construction
 - Non-valved type
 - 20 per pack
- Complies With:
• AS/NZS 1716: 2012



Item Code	Description	Bishops Code
DMP2-20	P2 Cup Respirator	55055052

P2 CUP RESPIRATORS WITH VALVE



- Easily adjustable nose bridge band for maximum seal and versatile fit
 - Wide ergonomic cup design
 - Twin adjustable head bands for improved comfort
 - Soft fibre construction
 - Exhalation valve to reduce heat build-up
 - 10 per pack
- Complies With:
• AS/NZS 1716: 2012



Item Code	Description	Bishops Code
PMP2V-10	P2 Cup Respirator With Valve	55055050

P2 CUP RESPIRATORS WITH VALVE – CARBON ACTIVATED



- Exhalation valve to reduce heat build-up
 - Easily adjustable nose bridge band for maximum seal and versatile fit
 - Twin adjustable head bands for improved comfort
 - Wide ergonomic cup design
 - Soft fibre construction
 - Active carbon filter protects against nuisance-level organic vapours in addition to P2 rating
 - Disposable and maintenance free
 - 10 per pack
- Complies With:
• AS/NZS 1716: 2012



Item Code	Bishops Code
DMP2VC-10	55055054

GET MORE AT BISHOPS



HAIR NETS & SHOE COVERS

Page 79

DUAL CARTRIDGE HALF MASK RESPIRATOR

- Suitable for cartridge size diameter 70 x 30mm
- Soft, durable and pliable rubber face piece
- Elastic head bands and a deep chin cup for a roomy, comfortable seal and easy exhaling
- One size
- Cartridges sold separately



Item Code	Bishops Code
SE1540	55055130

ADVANTAGE 200 HALF-FACE RESPIRATOR

- Soft and light facepiece for greater comfort and stability
- AnthroCurve Sealing Surface instantly conforms to each wearer's unique facial characteristics
- Delivers exceptional stability preventing the respirator collapsing during wear
- Certified to AS/NZS 1716:2012



Item Code	Size	Bishops Code
430357	Small	55055100
430356	Medium	55055105
430358	Large	55055110

6000 SERIES HALF FACE REUSABLE RESPIRATOR

- Low maintenance, simple and lightweight
- TPE facepiece
- Polycarbonate, high impact visor delivers a wide field of vision on full facepiece
- 4 point cradle head harness with bayonet connector
- Exhalation valve cover directs breath and moisture downward to reduce fogging
- Easy fastening neck strap
- Suitable for use with 3M™ gas, vapour and particulate cartridges and filters
- Weight: 82g



Item Code	Description	Size	Bishops Code
XA007702633	6100 Respirator	Small	55055235
XA007702674	6300 Respirator	Large	55055240

7700 SERIES HALF FACE MASK

- Soft, non-allergenic 100% silicone mask and seal provides excellent protection, comfort and fit
- Less dead air space meaning less exhaled air is re-breathed, encouraging increased worker productivity
- Quick to dismantle and clean, with all 9 parts replaceable
- Superior exhalation valve allows workers to feel cooler and more comfortable
- Variable thickness in sealing area
- Conforms to nose bridge for improved comfort and fit
- Built-up chin area maintains fit even while talking



Size	Bishops Code
Medium	55055096
Large	55055097

7600 SERIES FULL FACE MASK

- 100% medical grade silicone sealing area with dual flange for superior fit and comfort
- Converts to PAPR or supplied air respirator
- Latex-free
- Lens offers 200° field of vision
- Nose cup standard
- Reduces fogging and increases worker comfort
- The most comfortable full facepiece available delivers superior fit and durability
- Cartridges and filters sold separately



Size	Bishops Code
Medium/Large	55055090

7600 SERIES FULL FACE MASK

- Silicone mask provides all day comfort and avoids latex allergens common to economy masks
- Speech diaphragm provides clarity in noisy environments
- Flexible, wide, dual-flange sealing area fits all kinds of faces
- Five strap head harness and chin cup for a more secure fit, even during strenuous jobs requiring lots of movement
- Nose cup is standard, delivering less dead air space for increased worker comfort and productivity
- Channelled anti-fog lens offers a wide 200° field of vision, plus downward view facilitates going up and down ladders



Size	Bishops Code
Small	55055099

3S FULL-FACE RESPIRATOR

- Comfortable rubber compound material
- Wide sealing frame and deep chin stop
- Impact resistant polycarbonate lens with large field of vision
- Low exhalation resistance
- Quick and easy to don and doff
- Provides optimal air flow reducing fogging of the lens
- Size: Medium



Item Code	Bishops Code
D2055000	55055095



COMPLETING YOUR RESPIRATORY PROTECTION SET

1

CHOOSE YOUR FACE MASK

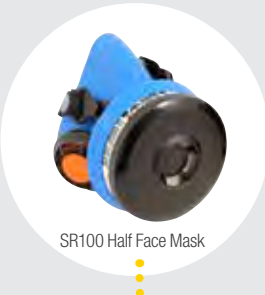

SR100 Half Face Mask



SR200 Full Face Mask

2

CHOOSE YOUR FILTERS



P3 Combination Filter



Gas/Vapour Filters



P3 Particle Filter

3

EXTEND THE LIFE OF YOUR FILTERS WITH A PRE-FILTER



Pre-Filter

+



Pre-Filter Holder

7700 SERIES REUSABLE PAINTERS SPRAY RESPIRATOR KIT

- Silicone, medical grade face piece
- Twin cartridge
- Exhalation valve
- Economical choice for spray painters and agricultural sprayers requiring respiratory protection from organic vapours and particulates
- Complies with AS/NZS 1716:2012

Includes:

- 7700 Series half-face respirator
- 2 x A2 rated organic vapour filters
- 2 x P2 rated pre-filters
- Spider/retainer for fitting P2 filter to A2 filter
- 2 x respirator wipes



Item Code	Bishops Code
RHSP-7700SM	55055080

7700 WELDERS P2 RESPIRATOR KIT

- Designed for welders requiring respiratory protection from welding fumes
- Complies with AS/NZS 1716:2012 Licence No: 0563

Includes:

- 1 x 7700 Series half-face respirator
- 2 x P2 rated pancake filters with nuisance level OV protection
- 2 x mask cleaning wipes



Item Code	Bishops Code
RHSP-7700WM	55055085

RESPIRATOR DUST CARTRIDGE



- Suits 55055130 respirator
- Protects against nuisance, toxic dusts, fumes and metallic fumes of low toxicity



Item Code	Bishops Code
SE156C	55055210

RESPIRATOR CHEMICAL CARTRIDGE



- Suit 55055130 respirator
- Protects against paint spray and organic vapours of low toxicity



Item Code	Bishops Code
SE156B	55055230

ADVANTAGE HALF-FACE FILTER CARTRIDGES

- Chemical and combination filters
- Suitable for use with the Advantage 200 range of half-face respirators
- Sold in pairs



55055116



55055118

Item Code	Description	Bishops Code
430372	A2P3 R Combination Cartridge - Pair	55055116
430373	A2B2E1K1 Chemical Cartridge - Pair	55055118

ADVANTAGE FULL-FACE COMBINATION FILTER CARTRIDGE

- P3 A2 B2 P3
- Suitable for Advantage 3200 full face respirators
- Provides protection against a wide range of toxic gases and particles
- PlexTech technology for more relaxed breathing
- Robust metal housing
- Compact and lightweight
- Class AB/ST



Item Code	Bishops Code
10097993	55055122

HONEYWELL FILTERS

- Filters for protection against particulates, gases, vapours and combinations of both
- Suitable for use with the 7700 series half mask and the 7600 series full face mask
- All filters are certified to AS/NZS 1716:2012 Lic 0562



Description	Bishops Code
A1 Organic Vapour Filter	55055127
A1E1 Organic Vapour & Sulphur Dioxide Filter	55055128
A1B1E1 Organic Vapour, Acid Gas, Sulphur Dioxide Filter	55055129
A1B1E1K1 + Formaldehyde & Hydrogen Fluoride	55055131
A1 P3 Organic Vapour, HEPA Filter	55055126
A1B1E1 P3 Organic Vapour, Acid Gas, Sulphur Dioxide, Formaldehyde, HF & HEPA	55055132
K1 P3 Ammonia, Methylamine, HEPA Filter	55055133
A1B1E1K1 P3 + Formaldehyde & Hydrogen Fluoride, HEPA Filter	55055134

P2 & P3 FILTERS & ACCESSORIES



Description	Bishops Code
P2 Pre-Filter	55055123
P2 Spider & Retainer	55055120
P2 Base Plate & Retainer	55055119
P2/P3 Pancake Filter	55055117
P2/P3 Nuisance OV/AG & Ozone Pancake Filter	55055125
Pre Filter Retainer	55055124

PARTICULATE DISC FILTERS

- Suitable for use with 3M 6000/7500 Series Half Face Respirators and 3M 6000/7000 Series Full Face Respirators
- 2 per pack



Description	Bishops Code
P2 Particulate Disc Filters	55055136
P3 Particulate Disc Filters	55055135

HOW FILTERS FIT TOGETHER

The diagram illustrates the assembly of a filter. At the top is a 'Filter Cartridge' (a blue and white rectangular unit). Below it is a 'Filter' (a white circular disc). At the bottom is a 'Retainer' (a white plastic frame). Dotted lines indicate the alignment and fit between these components.

GET MORE AT BISHOPS

INDUSTRIAL WET & DRY VACUUMS

Page 409



SELECTING HEARING PROTECTION

Consequences of noise

Exposure to loud noise can cause damage to our hearing, possibly resulting in permanent hearing loss or tinnitus. Sounds greater than 85dB(A) are likely to cause these problems and repeated exposure can cause other health issues including stress, fatigue, sleep disturbance and anxiety.

What does SLC80 mean?

Under AS/NZS 1270 hearing protection is tested and an SLC80 rating is allocated to the product. The SLC80 rating is defined as the difference between the sound level of the environment in which the hearing protection device is worn and the sound level reaching the individual wearing the product. The recommended target in ear exposure for workers is 80dB.

Determined by the SLC80 rating, a class rating from 1-5 is assigned.

Noise Level dB (A)	SLC80 Range (dB)
Less than 90	10 to 13
90 to less than 95	14 to 17
95 to less than 100	18 to 21
100 to less than 105	22 to 25
105 to less than 110	26 or greater

**All calculations based on the maximum exposure limit of 85dB for 8 hours*

Example for selecting a class for earmuffs

100dB – 80dB = 20dB (which falls into the Class 3 category)

Noise exposure guidelines

For every 3dB over 85dB, the allowable exposure time before impairment can occur is halved.

Continuous dB	Permissible Exposure Time
85dB	8 Hours
88dB	4 Hours
91dB	2 Hours
94dB	1 Hours
97dB	30 Minutes
100dB	15 Minutes
103dB	7.5 Minutes
106dB	3.75 Minutes
109dB	1.875 Minutes
112dB	0.9375 Minutes
115dB	0.46875 Minutes

For areas exceeding 110dB please seek specialist assistance. It is important to select and correctly fit appropriate hearing protection.

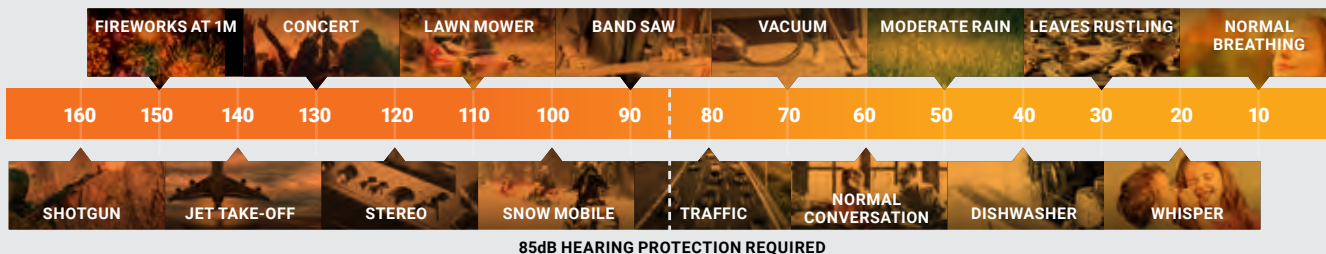

For areas exceeding 110dB please seek specialist assistance. It is important to select and correctly fit appropriate hearing protection.

Steps to achieve a seamless hearing conservation program in your workplace

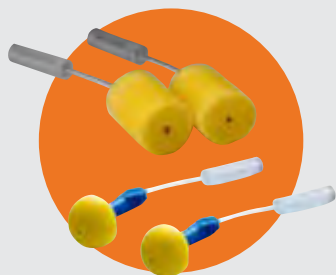

Accurate noise detection

An effective hearing conservation program begins with measurement. Accurate measurement of an employee's exposure to hazardous noise is essential. A noise assessment (also known as survey) can help identify workers at risk, determine who needs to be included in your program, and select the proper noise control measures and appropriate hearing protectors to help reduce these risks.



Adaptable hearing protection

A variety of types and sizes of earplugs and earmuffs are available, helping your team determine the right fit for each person, and the right protection for the application. These innovative products are designed for comfortable, extended wear, and can help your team comply with your hearing protection program.



Fit test validation

Integrating hearing protection fit testing into your hearing conservation program benefits everyone from new hires to high-risk workers. A fit-testing system makes it easier to fit, train and motivate workers and to assess and manage the long-term performance of your hearing conservation program.

QB2 BANDED REUSABLE EARPLUGS

- Designed for environments with intermittent noise hazards
 - Smooth, ergonomic pods fit in the ear for maximum protection
 - Band design prevents ear pods from touching dirty or contaminated surfaces
 - Lightweight and portable
 - Pods rest partially in the ear canal
 - Replacement pods available
 - SLC80 21dB (Class 3)
- Complies with:**
- AS/NZS 1270: 2002

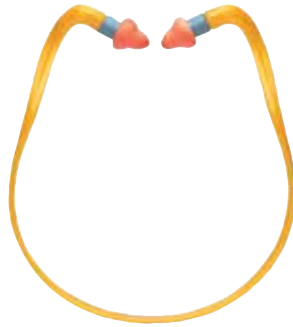

Item Code	Bishops Code
QB2HYG	55050053

DISPOSABLE LASER TRAK CORDED DETECTABLE EARPLUGS

- Easily detectable bright colours
 - Non-ferrous metal grommet
 - Self-adjusting polyurethane foam expands to fit almost any wearer
 - Contoured T-shape provides easy insertion and wear
 - SLC80 25dB (Class 4)
 - Orange/blue
- Complies with:**
- AS/NZS 1270: 2002



Item Code	Bishops Code
LT-30	55050046

UNCORDED FOAM EARPLUGS

- The very soft polyurethane foam provides a comfortable and close fitting seal against harmful noise
- Orange
- 200 per box
- 25dB (Class 4)
- Complies to standard AS/NZS 1270.2002



Item Code	Bishops Code
SE1374	55050010

HI-VIS EARPLUGS

- Soft PU material
 - Tapered shape
 - Roll-down fit
 - High visibility colour ensures onsite compliance
 - SLC80 26dB (Class 5)
- Complies with:**
- AS/NZS 1270: 2002



Item Code	Description	Quantity	Bishops Code
EPU-200	Uncorded	200 Pairs	55050009
EPC-100	Corded Earplugs	100 Pairs	55050019

HI-VIS CORDED REUSABLE EARPLUGS

- Soft silicone material
 - Flanged shape
 - Push-in fit
 - Non-toxic & environmentally friendly
 - High visibility colour for onsite compliance
 - SLC80 24dB (Class 4)
 - Colour: hi-vis yellow
 - 100 pairs
- Complies With:**
- AS/NZS 1270: 2002



Item Code	Bishops Code
EPRC-100	55050024

MAX® UNCORDED EARPLUGS

- Bell shape provides maximum in-ear comfort
 - Contoured design makes earplug easier to insert and less likely to back out of ear canal
 - Polyurethane foam enhances comfort over long periods of wear
 - Smooth, soil resistant closed cell foam skin prevents dirt build up
 - SLC80 26dB (Class 5)
 - 200 pairs
- Complies with:**
- AS/NZS 1270: 2002



Item Code	Bishops Code
MAX-1	55050025

LASER LITE® EARPLUGS

- Vibrant colours make the Laser Lite® a highly visible earplug and allows at-a-glance determination of worker compliance
- Made from low pressure polyurethane foam
- Contoured T-shape design makes for easy handling
- The closed cell-foam skin is smooth and soil resistant, eliminating build up of dirt
- Magenta/yellow
- SLC80 25dB (Class 4)



Description	Bishops Code
Uncorded, Individual Poly Bag – 200 Pairs Per Box	55050012
Polycord, Individual Poly Bag – 100 Pairs Per Box	55050022
Uncorded LS-500-A Dispenser Refill – 500 Pairs	55050014
Uncorded LS-400-A Dispenser Refill – 200 Pairs	55050013

GET MORE AT BISHOPS ▶



WORKSHOP FANS

Page 331



EARMUFFS

SAFETY EQUIPMENT & CONSUMABLES

DEEP CUP EARMUFFS

- Headband style
- High attenuation
- 33dB (Class 5)
- EN352-1



CLASS 5

Item Code	Bishops Code
SE1317	55050120

VS110 VERISHEILD 100 SERIES NECKBAND EARMUFFS

- Large dimension range to comfortably fit a wide range of head sizes
- Wide cup openings ideal for workers with large ears or who wear hearing aids
- Lightweight cushioned headband
- Memory foam ear cushions for greater comfort and attenuation
- ABS moulded with internal baffle design for lighter weight
- Dielectric options with Sound Management Technology (SMT) also available
- SLC80 25dB (Class 4)
- Complies with standards ISO 9001 / 2000



CLASS 4

Item Code	Bishops Code
1035146-VS	55050229

HEADBAND EARMUFFS

- High quality ultra tough ABS plastic
- Large soft ear pads for great fit and seal
- Adjustable headband for secure fit
- Insulated headband for high voltage environments
- SLC80 33dB (Class 5)

Complies With:
• AS/NZS 1270: 2002



CLASS 5

Item Code	Bishops Code
EMHB33	55050112

HI-VIS NECK BAND EARMUFFS

- High quality ultra tough ABS plastic
- Large soft ear pads for great fit and seal
- Neckband style for less interference with other PPE
- Stainless steel neckband
- High visibility colour for added safety
- SLC80 32dB (Class 5)

Complies With:
• AS/NZS 1270: 2002



CLASS 5

Item Code	Bishops Code
EMNB30	55050213

FOLD-UP TYPE EARMUFFS

- Large foam-filled cushions with deep ear cups
- Compact folding design is good for storage or carrying in a pocket
- Approved 30db (Class 5)
- Complies to standard ANSI 53.19



CLASS 5

Item Code	Bishops Code
SE1340	55050115

HARD HAT ATTACH EARMUFFS

- High quality ultra tough ABS plastic
- Large soft ear pads for great fit and seal
- Cap mounted to suit most compatible hard hats
- Insulated for high voltage environments
- SLC80 27dB (Class 5)

Complies With:
• AS/NZS 1270: 2002



CLASS 5

Item Code	Bishops Code
EMCA27	55050212

OVER-HEAD EARMUFFS

- Headband style, lightweight
- Soft foam-filled cushions provide a good seal for protection against harmful noise
- Can be worn in three positions
- Can be worn with safety helmet
- Adjustable reinforced headband
- SNR27db (Class 5), NRB20db
- Complies to standards ANSI S3-19 and CE EN 352.1



CLASS 5

Item Code	Bishops Code
	55050110

VS130 VERISHIELD 100 SERIES HELMET ATTACHED EARMUFFS

- Large dimension range to comfortably fit a wide range of head sizes
- Wide cup openings ideal for workers with large ears or who wear hearing aids
- Lightweight cushioned headband
- Memory foam ear cushions for greater comfort and attenuation
- ABS moulded with internal baffle design for lighter weight
- Dielectric options with Sound Management Technology (SMT) also available
- SLC80 32dB (Class 5)
- Complies with standards ISO 9001 / 2000



CLASS 5

Item Code	Bishops Code
1035129-VS	55050218

UNVENTED SAFETY HELMETS



- Complies to standard ANSI Z89.1 and EN 397:1995
- Polyethylene shell assembled with 6 point adjustable nylon ratchet suspension
- Chin strap excluded
- Slotted sides to accommodate ear muffs and face shields
- ABS plastic



Colour	Bishops Code	Colour	Bishops Code
White	55045010	Green	55045050
Orange	55045020	Fluoro Yellow/Green	55045060
Yellow	55045030	Red	55045070
Blue	55045040	-	-

UNILITE VENTED SAFETY HELMET



- Peaked cap
- 6 point harness for stability and comfort
- Type 1 ABS general purpose safety helmet
- Vented for additional cooling
- ASNZS1801:1997

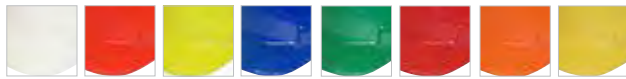

Item Code	Colour	Bishops Code	Item Code	Colour	Bishops Code
TA570:WH	White	55045858	TA570:GN	Green	55045846
TA570:OR	Orange	55045848	TA570:RD	Red	55045854
TA570:YE	Yellow	55045852	TA570:FLOR	Fluoro Orange	55045842
TA570:BL	Blue	55045840	TA570:FLYE	Fluoro Yellow	55045844

SAFETY HELMET WITH CLIP & LIGHT BRACKET



- Fitted with ratchet type 6 point harness
- Head lamp and bracket clip included
- ABS plastic
- White
- Complies to standard ANSI Z89.1



Item Code	Bishops Code
SE1718	55045090

BUMP CAP



- ABS shell with foam spacer
- Hi-vis fabric with ventilation mesh to reduce heat and encourage air circulation for increased wearer comfort
- Reflective detail on the cap improves visibility
- Great for protection against light impact bumps and scrapes
- Velcro® back for easy adjustment



Item Code	Colour	Bishops Code
BCLP-O	Navy	55045000
BCLP-Y	Hi-Vis Yellow	55045005

SAFETY HELMET HI-VIS BRIM WITH NECK FLAP

- Detachable wide hat brim and neck flap
- Suitable for most brands of helmets
- Hi-vis orange
- Helmet not included



Item Code	Bishops Code
EHC7400R	55045820

CANVAS SUN HATS

- Wide and protective brim
- Adjustable chin strap
- Available in white, navy blue and green



Colour	SMALL	MEDIUM	LARGE	X-LARGE
	Bishops Code	Bishops Code	Bishops Code	Bishops Code
White	55591011	55591012	55591013	55591014
Navy Blue	55591015	55591016	55591017	55591018
Green	55591019	55591020	55591021	55591022

GET MORE AT BISHOPS ▶



SUN UMBRELLA

Page 413



HEIGHT SAFETY

Safety harnesses

Ensure your team's safety at heights by making sure they are kitted out with the best fit-for-purpose harness for the job. This guide will walk you through some of the things to consider when selecting your harness.

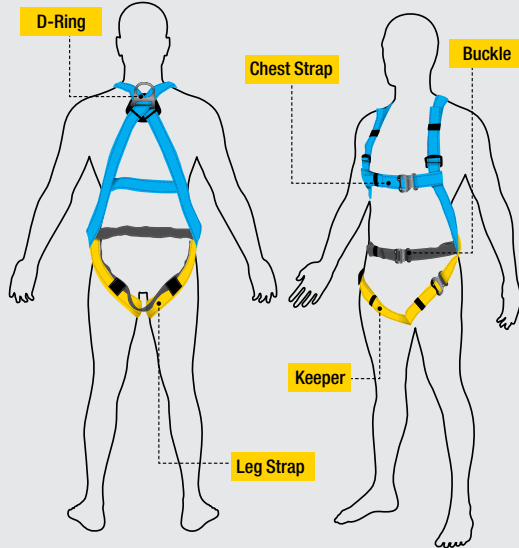

Harness features

D-Ring – Height Safety Harnesses have fall arrest D-Rings, used to connect the harness to an appropriate lanyard or SRL. D-Rings are most commonly found on the rear of the harness however some models include front and side attachment points for confined space or rescue situations.

Webbing – Webbing refers to the harness straps, usually made out of strong polyester. This polyester webbing can be UV stabilised for strength retention even after outdoor use. Webbing can also have other special features making it more suitable for certain applications.

Buckles – Most buckles are made of aluminium, which is strong and lightweight. Buckles can also be made out of plastic and stainless steel. Stainless steel buckles and hardware are suitable for underground environments providing better longevity.

Suspension Trauma Straps – In the event of a fall, suspension trauma straps help to alleviate the risk of suspension trauma. Suspension trauma is caused by the pooling of blood due to the restriction of major arteries in the legs. Suspension trauma straps are manually deployed in the event of a fall, allowing the worker who is suspended to effectively stand on their harness to alleviate pressure around the legs and assist with blood flow.

Some premium harnesses include suspension trauma straps. If your harness does not include straps, they can be purchased separately and attached.

Harness sizing chart

Harnesses must be properly fitted to provide adequate fall protection. An ill-fitting harness will not provide the same standard of protection as a properly fitted harness.

The below size chart is designed to be utilised as a guide. You should always check follow the manufacturers size guidelines to ensure a correct fit.

Height in m	2.0	LARGE																																									
	1.9																																										
	1.8																																										
	1.7															MEDIUM																											
	1.6																													SMALL													
	1.5																																										
		50	60	70	80	90	100	110	120	130	140																																
		Body Weight in kg																																									

Disclaimer: This editorial contains only a general description of the products shown. While uses and performance capabilities are described, under no circumstances shall the products be used by untrained or unqualified individuals and not until the product instructions including any warnings or cautions provided have been thoroughly read and understood. Only they contain the complete and detailed information concerning proper use and care of these products.

BODY SAFETY HARNESS

- Parachute type
- 50mm width nylon belt
- easily adjustable friction buckle leg straps to absorb shock from fall-arresting forces
- D-Ring allows maximum distribution of shock load
- Complies with CE EN361



Item Code	Bishops Code
SE1846	55010440

1100 TRADIE FULL BODY FALL ARREST HARNESS



- Rear fall arrest D
- Front fall arrest loops
- Lightweight
- Carbon steel buckles
- Fully adjustable shoulder and leg straps
- Easy to fit with no restriction
- Breathable rear mesh panel aids donning
- Simple to adjust
- AS1981.1 2020 Certified



Item Code	Bishops Code
1100 TRADIE	55010423

1100 ERGO FULL BODY FALL ARREST HARNESS



- Rear fall arrest D
- Front fall arrest D
- Confined space attachment loops
- Fully adjustable leg and shoulder straps
- Breathable rear mesh panel
- Hi-vis webbing
- Suspension trauma relief straps
- AS1891.1 2020 Certified



Item Code	Bishops Code
1100 ERGO-BP	55010421

1150 EWP FULL BODY FALL ARREST HARNESS & LANYARD



- Rear fall arrest D
- Front fall arrest loops
- Lightweight
- Comes with permanently attached 1.8m shock absorbing lanyard
- Carbon steel buckles
- Fully adjustable shoulder and leg straps
- Easy to fit with no restriction
- Breathable rear mesh panel aids donning
- Simple to adjust
- AS1891.1 2020 Certified



Item Code	Bishops Code
1150 EWP	55010414

1107 ERGOiPLUS PREMIUM FULL BODY FALL ARREST HARNESS



- Rear fall arrest D and front fall arrest D
- Quick connect buckles
- iWeb inspection compliant webbing
- Xtreme guard oil and water resistant webbing
- Padded waist band and side Ds
- Rear fall arrest extension strap
- Confined space attachment loops
- Fully adjustable leg and shoulder straps
- Fully padded leg and shoulder straps
- Suspension trauma relief straps
- AS1891.1 2020 Certified



Item Code	Bishops Code
1107-ERGOiPLUS	55010430

1107 ERGO FULL BODY FALL ARREST HARNESS



- Rear fall arrest D
- Front fall arrest D
- Padded waist band and side Ds
- Rear fall arrest extension strap
- Confined space attachment loops
- Fully adjustable leg and shoulder straps
- Breathable rear mesh panel
- Hi-vis webbing
- Suspension trauma relief straps
- AS1891.1 2020 Certified



Item Code	Bishops Code
1107 ERGO-0	55010419

1500 ERGO FULL BODY TOWER WORKER HARNESS



- Rear fall arrest D
- Front fall arrest loops
- Padded waist band and side Ds
- Auxiliary buttock pole strap with 75mm rings
- Confined space attachment loops
- Fully adjustable leg and shoulder straps
- Breathable rear mesh panel
- Hi-vis webbing
- Suspension trauma relief straps
- AS1891.1 2020 Certified



Item Code	Bishops Code
1500 ERGO-0	55010429

1100 ERGOiPLUS PREMIUM FULL BODY FALL ARREST HARNESS



- Rear fall arrest D
- Front fall arrest D
- Quick connect buckles
- iWeb inspection compliant webbing
- Xtreme guard oil and water resistant webbing
- Confined space attachment loops
- Fully adjustable leg and shoulder straps
- Fully padded leg and shoulder straps
- Suspension trauma relief straps
- AS1981.1 2020 Certified



Item Code	Bishops Code
1100 ERGOiPLUS	55010424

H-STYLE VS X-STYLE – WHAT'S THE DIFFERENCE?

There are a few important differences between an H-Style and an X-Style harness.



The H-Style harness has two over-the-shoulder straps, held together with a strap across the torso forming an H shape. This harness is considered to be the most general purpose.



The X-Style harness forms an X across the torso. This style is particularly good for women as it doesn't put pressure on the chest area.



ABC OF FALL PROTECTION

The ABCs of fall protection refer to the essential components of an effective fall protection system.



A Anchorage
Anchorage connectors play a vital role in fall protection by providing a secure point of attachment to an existing structure. They can be temporary or permanent and must be able to support 15kN (1,500kg) for a single person anchorage, or 21kN for a two person anchorage, as stipulated in AS/NZS 1891.4 and AS/NZS 5532.



B Body support
Body support refers to the full body harness worn by workers that supports their weight and allows them to connect to anchorage points. Harnesses are designed to be comfortable while being supportive and come in many variations to suit different industries or applications. Full body harnesses must always be properly fitted to ensure maximum protection.



C Connectors
Connectors attach the harness to the anchorage. The most common connectors are shock absorbing lanyards and self-retracting lifelines, which are designed to reduce the force of a fall.



D Descent/rescue
Descent and rescue systems are used for the retrieval of a worker who may be injured or otherwise incapacitated, often due to a fall or entrapment in a confined space.



E Education
Education on fall protection and fall arrest is essential. Employees should ensure their workers are adequately trained before working at height.



F Fall protection for tools
Preventing dropped object incidents is an important aspect of working safely at height, as dropped tools and other objects pose a safety risk to those working below. Ensure objects are not dropped by using appropriate prevention and protection when working with objects at height.

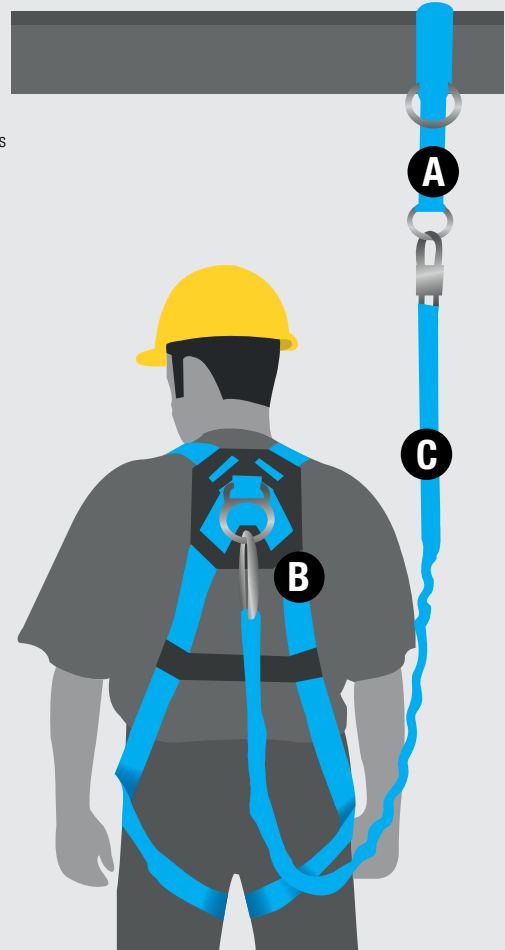

Fall Restraint vs Fall Arrest

Although they sound similar, fall restraint and fall arrest are two different things.

Fall restraint is a strategy that prevents a worker from falling. Utilising a Type 1 device, workers are prevented from moving into a hazardous position from which they may fall.

Fall arrest is a strategy that aims to reduce the impact of a fall. In a fall arrest system, a worker will be allowed to fall and the system will minimise injury as much as possible by ensuring they do not fall onto a platform or object below, and by using technologies such as shock absorption.

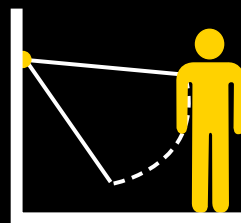

Fall restraint

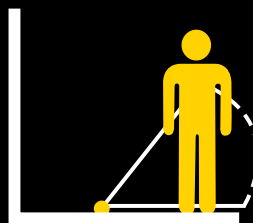

Fall arrest

Type 1

Type 1 fall arresters are manually adjusted devices that are attached to a fixed anchorage line. They can move up and down the fixed line and keep the user in a fall restraint position.

Type 2

Type 2 fall arresters are automatically retracting devices that lock when loaded with a fallen worker's weight, which provides fall arrest. They are usually attached to fixed anchorage points and include self-retracting lifelines, personal fall limiters and inertia reels.

Type 3

Type 3 fall arresters are similar to Type 2 fall arresters but with an inbuilt retrieval mechanism that helps in rescue situations.

Type 4

Type 4 fall arresters are similar Type 2 fall arresters but with an inbuilt self-rescue feature.

HEIGHT SAFETY & ROOF WORKERS KIT

Kit Includes:

- 1100 TRADIE/Spectre harness
- 3108SA-RP rope line x 15m with energy absorber
- 3506 Spectre anchor attachment sling
- K2 karabiner
- Backpack kit bag



Item Code	Bishops Code
6001SA-SPECTRE-0	55010540

SHOCK ABSORBING LANYARD

- Shock absorbing system attached to harness allow a soft, stable stop during a fall
- Provides best protection against fall-arresting forces
- Complies with CE EN361

Includes:

- 1 x 1.5m single nylon webbing lanyard
- 1 x connector
- 1 x double-lock hook
- 1 x 45mm width absorber



Item Code	Bishops Code
SE1862	55010460

3058E ERGO TWIN ELASTICATED LANYARD

- Twin leg elasticised webbing shock absorbing lanyard
- Fitted with snap hook at energy absorber end and scaffold hooks at free ends
- 1.4m to 1.8m in length
- Hi-vis webbing
- AS 1891.1- 2007 Certified



Item Code	Bishops Code
3058E-0x1.8	55010448



3053 ERGO LANYARD

- Single leg webbing shock absorbing lanyard
- Fitted with snap hook at energy absorber end and snap hook at free end
- 1.8m in length
- Hi-vis webbing
- AS1891.5 2020 Certified



Item Code	Bishops Code
3053-GP	55010463

3055 ERGO LANYARD

- Single leg webbing shock absorbing lanyard
- Fitted with snap hook at energy absorber end and scaffold hook at free end
- 1.8m in length
- Hi-vis webbing
- AS1891.5 2020 Certified



Item Code	Bishops Code
3055-SCAFF	55010475

3058 ERGO TWIN LANYARD

- Twin leg webbing shock absorbing lanyard
- Fitted with snap hook at energy absorber end and scaffold hooks at free ends
- 1.8m in length
- Hi-vis webbing
- AS1891.5 2020 Certified



Item Code	Bishops Code
3058-ACCESS	55010449

HEAVY DUTY ANCHOR STRAP

- Attachment strap
- Webbing construction
- 22kN rating (choked)
- Comes with large and small D's for choking/reaving
- Overall length: 1.3m



Item Code	Bishops Code
3501-BP	55010515



GET MORE AT BISHOPS ▶



STEEL CAP BOOTS
From Page 84



HEIGHT SAFETY ANCHORS, LINES & KITS

SAFETY EQUIPMENT & CONSUMABLES

ROUND ANCHOR STRAP

- Strong 1m round sling style attachment sling
- Minimum break strength 7kN
- Other lengths available upon request



Item Code	Size	Bishops Code
3506-BS-RP	1m	55010510

ADJUSTABLE POLE STRAP

- Pole strap
- Fitted with adjuster and snap hooks
- Comes with polyester webbing wear sleeve
- 2.5m adjustable



Item Code	Bishops Code
2700-RP	55010511

ROOF ANCHOR – TEMPORARY METAL & TIMBER

- Temporary one person roof anchor that can be installed onto a metal or tiled roof
- Multi-directional height safety anchor designed to maximise energy absorption
- Used when there is no permanent safety anchors
- Complies to AS1891.4



Item Code	Bishops Code
FASTLINK	55010520

ANCHORAGE ROPE LINE

- Fall arrest rating
- Horizontal orientation of use
- Fitted with RF1 Type 1 adjuster and fixed energy absorber park
- 15m anchorage line
- Made from 11mm Kernmantle rope
- Other lengths available upon request



Item Code	Bishops Code
3108SA-RP	55010532

HORIZONTAL SAFETY LINE

- Two person horizontal safety line
- 18m length
- Comes with 20035 ABS ratchet and two safety shackle connectors



Item Code	Bishops Code
3400-UK-0x18	55010535

GOTCHA™ ORIGINAL RESCUE KIT

- First pre-assembled remote rescue kit on the market
- Enables casualties to be raised or lowered to safety
- Kit contains rope, upper and lower pulleys, Gotcha™ Frog, telescopic pole, rope controller, rope grabber, attachment sling and karabiners, with carry bag
- Comes with 50m of rope allows approx 17m effective length in high anchor mode
- 7kg kit weight



Item Code	Bishops Code
GOTCHA-KIT-0	55010546

SAVERLINE FALL ARREST BLOCKS – SRL

- Webbing lifeline
- 150kg maximum capacity
- Comes with cut resistant webbing



Item Code	Effective Length	Bishops Code
SVLB-2	2.0m	55010658
SVLB-3	3.0m	55010657

3201 RETRACTING LANYARD – SRL

- Lightweight retracting lanyard ideal for light duty applications
- Comes with triple action karabiners and energy absorber
- 2.25m long, 50mm webbing
- Steel and plastic casing
- 100kg load rating



SpanSet

SPF 50+ SUNSCREEN

- Very high protection sunscreen
- Dry touch formula
- Protects against UVA and UVB rays
- 4 hour water resistant
- Non-greasy, non-oily
- Easy rub in
- Contains Vitamin E and Aloe Vera



Item Code	Bishops Code
3201-0x2.5	55010582

RETRACTABLE TOOL LANYARDS

KING TONY

- Warning load weight tags to attach tools
- Nylon tether with steel spring inside to absorb the shock of a dropped tool
- Increases safety while working
- Ergonomic design for hand reach capacity
- Length capacity: 800–13,00mm



Item Code	Hook Type	Weight	Bishops Code
79A21-30	2 x Lock Snaps	106g	55010506
79A22-30	1 x Lock Snap, 1 x Fixed Loop	89g	55010507

Item Code	Size	Bishops Code
ISPS5125	125ml	32818067
SS500-50	500ml	32818068

HANDY FIRST AID KIT

- Embroidered, hard wearing, zippered canvas case
- Ideal for the glove box, cupboard or suitcase when travelling
- Practical internal layout

Includes:

- 1 x 10 pack plastic adhesive strips
- 1 x conforming bandage – 50mm
- 1 x CPR card
- 1 x eye pad
- 1 x first aid pamphlet
- 1 x pair disposable gloves
- 1 x plastic magnifier
- 2 x plastic bags – small and medium
- 1 x resuscitation shield
- 1 x paper tape – 125mm x 5m
- 1 x 12 pack assorted safety pins
- 1 x scissors small
- 2 x sodium chloride satchets
- 1 x splinter probe disposable
- 1 x triangular bandage
- 1 x tweezers
- 1 x wound dressing – No.15
- 2 x wound wipes



Item Code	Bishops Code
848794	55090105

SNAKE BITE KIT

- Perfect size for keeping in the work vehicle
- Soft case

Includes:

- 2 x crepe bandages, heavy FAC, 10cm x 2m
- 1 x black fabric belt bag with velcro closure
- 1 x snake bite treatments instructions sheet



Item Code	Bishops Code
T30020	55090575

GET MORE AT BISHOPS



COOL-IT® CLOTHING

Page 66



FIRST AID KITS

SAFETY EQUIPMENT & CONSUMABLES

GENERAL PURPOSE FIRST AID KIT

- Portable hard case
- A generous first aid kit for around the home or to take on holidays
- Features a mounting bracket and positive click holding tabs
- 260(w) x 170(h) x 80(d)mm

Includes:

- 1 x emergency thermal blanket
- 1 x wound dressing – No.15
- 1 x conforming bandage – 750mm x 1.8m
- 1 x healaid cream – 25g
- 1 x fine stainless steel forceps – 125mm
- 1 x sharp/blunt stainless steel scissors – 125mm
- 1 x first aid booklet
- 1 x triangular bandage – 1,100 x 1,550mm
- 2 x sodium chloride – 15ml 0.9%
- 1 x 5 pack sterile gauze pieces – 750mm
- 1 x 30+ sunscreen sachet – 10ml (4hr + water resistant)
- 1 x porous poly bag tape paper – 125mm x 5m
- 1 x basic dressing pack
- 1 x combine dressing – 100 x 200mm
- 1 x medium crepe bandage – 750mm x 2m
- 1 x 50 sheer plastic strips – 190 x 720mm
- 1 x non-adherent – 750 x 100mm
- 2 x alcohol-free wound wipe
- 1 x 12 pack assorted safety pins
- 1 x plastic magnifier
- 1 x eye pad
- 1 x pair latex gloves



Item Code	Bishops Code
T33815	55090110

PORTABLE WORKPLACE FIRST AID KIT

- Level 1 compliant, low risk
- Polypropylene hard case
- Designed for a small to medium workplace (25–100 employees)
- 190(h) x 420(w) x 225(d)mm

Includes:

- 50 x adhesive strips
- 1 x disposable gallipot
- 2 x crepe bandage – 100mm
- 1 x adhesive tape paper – 250mm x 5m
- 1 x emergency thermal blanket
- 1 x pair nitrile gloves
- 10 x alcohol wipes
- 5 x eye pad single
- 1 x antiseptic cream – 25g
- 1 x eyewash and irrigation solution – 100ml
- 10 x non-adherent dressing – 750 x 100mm
- 1 x burns sterile dressing – 700 x 750mm
- 1 x fine forceps – 125mm
- 1 x register of injury book and pencil
- 3 x conforming bandage – 50mm
- 1 x first aid pamphlet
- 1 x CPR resuscitation card
- 3 x conforming bandage – 750mm
- 2 x 5 pack gauze sterile pieces – 750mm
- 1 x disposable resuscitation face shield
- 3 x plain clip seal medium plastic bags
- 1 x pack 100 cotton buds
- 1 x instant ice pack
- 1 x 12 pack safety pins assorted
- 1 x sharps container
- 1 x kidney dish
- 1 x sharp/blunt scissors
- 10 x wound wipes
- 1 x 10 pack splinter probe
- 4 x triangular bandage – 1,100 x 1,550mm
- 3 x wound dressing – No.15
- 6 x sodium chloride – 20ml



Item Code	Bishops Code
T101171	55090120

WORKPLACE FIRST AID KIT

- Level 1 compliant, low risk
- Wall mounted powder coated steel cabinet
- Suitable for construction sites with less than 25 employees and other workplaces with less than 100 employees
- 240(w) x 390(h) x 150(d)mm

Includes:

- 50 x adhesive strips
- 1 x adhesive tape paper – 250mm x 5m
- 10 x alcohol wipes
- 1 x antiseptic cream – 25g
- 1 x burns sterile dressing – 700 x 750mm
- 3 x conforming bandages – 50mm
- 3 x conforming bandages – 750mm
- 10 x non-adherent dressings – 750 x 100mm
- 1 x 5 pack gauze sterile pieces – 750mm
- 1 x 100 pack cotton buds
- 1 x disposable gallipot
- 1 x emergency thermal blanket
- 1 x fine forceps – 125mm
- 1 x first aid pamphlet
- 1 x instant ice pack
- 1 x kidney dish
- 2 x crepe bandages – 100mm
- 1 x pair nitrile gloves
- 3 x plastic bags
- 1 x resuscitation card & shield
- 1 x 12 pack assorted safety pins
- 1 x sharp/blunt scissors
- 1 x sharps container
- 6 x sodium chloride – 20ml
- 1 x 10 pack splinter probe
- 5 x single eye pads
- 1 x eyewash and irrigation solution – 100ml
- 4 x triangular bandages – 1,100 x 1,550mm
- 3 x wound dressings – No.15
- 10 x wound wipes
- 1 x register of injuries book and pencil



Item Code	Bishops Code
T101169	55090122

HIGH RISK PORTABLE FIRST AID KIT

- Soft case with multiple storage compartments
- Suitable for construction sites with more than 25 employees and other workplaces with more than 100 employees
- 500(w) x 320(h) x 285(d)mm

Includes:

- 2 x boxes of 50 adhesive strips
- 1 x adhesive tape paper – 250mm x 5m
- 10 x antiseptic cream sachets
- 2 x burns sterile dressing – 700 x 750mm
- 3 x conforming bandages – 50mm
- 3 x conforming bandages – 750mm
- 8 x triangular bandages – 1,100 x 1,550mm
- 1 x 100 pack cotton buds
- 2 x crepe bandages – 100mm
- 1 x disposable gallipot
- 1 x emergency thermal blanket
- 5 x single eye pads
- 1 x fine forceps – 125mm
- 2 x 5 pack gauze sterile pieces – 750mm
- 2 x instant ice packs
- 10 x non-adherent dressings – 750 x 100mm
- 10 x non-adherent dressings – 50 x 750mm
- 1 x penlight examination torch
- 10 x plastic bags
- 1 x resuscitation card & shield
- 12 x safety pins
- 1 x sharp/blunt scissors
- 1 x sharps container
- 12 x sodium chloride – 20ml
- 10 x splinter probe
- 10 x wound dressing – No.15
- 20 x wound wipes
- 1 x kidney dish
- 1 x pair nitrile gloves
- 1 x first aid booklet
- 1 x register of injuries book and pencil



Item Code	Bishops Code
T101170	55090126

EYEWASH SOLUTION

- Emergency saline solution bottle with built-in eye cap
- Hygienically sealed until required
- Twist top to break internal seal in an emergency
- Moulded eye cap features multiple streams for a smooth flow of solution while flushing
- Instructions included on the label
- FAC colour coded blue
- 500ml



Item Code	Bishops Code
876234	55090602

EYEWASH SOLUTION REFILL BOTTLE

- Use to refill eyewash stations
- Sterile isotonic solution
- 946ml (32oz)



Item Code	Bishops Code
EWB944	55090690

SALINE EYEWASH

- Personal emergency eyewash bottle
- Suitable for initial first aid treatment
- Twist-top squeeze bottle
- Comes with wall mount and signage
- Bottle: 944ml



Item Code	Bishops Code
EWB944ECS	55090703

WATER PRESERVING SOLUTION

- Antibacterial water additive
- For use with GravityFlo Eyewash Station
- Each bottle preserves up to 34L of water
- 240ml bottle
- 4 per pack



Item Code	Bishops Code
H-ANTBAC34	55090692

PERSONAL EYEWASH STATION & SALINE EYEWASH SOLUTION



- Sterile, buffered, isotonic solution
- Ideal for flushing and irrigating the eyes to remove toxic substances, loose foreign material, air pollutants, chlorinated water and to refresh irritated or tired eyes
- Station includes 2 x 944ml solution bottles



Item Code	Description	Bishops Code
SE EWS944	Eye Wash Station	55090605
SE EWR 944B4	Replacement 944ml Solution Bottle	55090701

WALL-MOUNTED EYEWASH STATION

- Hand-operated
- Cover ensures the unit is protected from contaminants at all times
- When opened, the flow of flushing water begins immediately
- Comes with integral lid, aerated diffusers, flow regulator stainless steel tubes and complete maintenance and installation instructions
- Stay-on ball valve



Item Code	Bishops Code
H-STD45G	55090630

PORTABLE GRAVITY FED EYEWASH



- Flushes hazardous substances from the eyes
- Ideal for remote locations or sites without plumbed water
- 34.1L (9 gallon) capacity
- Full tank streams water for 15 minutes at 1.5L per minute
- Lightweight, compact and portable with carry handle
- High density polyethylene tank with yellow fold down arm to activate flow, keeping hands free to hold eyelids open
- Includes bracket for wall mounting
- Label for recording inspection dates
- Each unit is supplied with 1 x 250ml bottle of eyewash preservative to help prevent the growth of bacteria in the eyewash tank
- Manufactured to meet Australian Standard AS4775-2007



Item Code
SCSS-EG34

SPECIAL ORDER: PLEASE QUOTE ITEM CODE UPON ORDERING THIS PRODUCT

GRAVITYFLO EYEWASH STATION

- Self-contained and portable
- Can be wall, table or cart mounted
- Delivers up to 34L of flushing solution at ambient temperature
- Carry handle for convenience
- Pinch valve ensures positive water flow of minimum 1.6L/min (0.4gal/min) within one second of activation
- 580(l) x 250(w) x 400(h)mm



Item Code	Bishops Code
SE 5000	55090615



EMERGENCY WASH STATIONS

GRAVITY EYEWASH STATIONS

- Portable, refillable emergency gravity eye wash stations



SE 4000



SE 4300



SE 4060



SE 4400



SE 4210B4

Item Code	Capacity	Activation
SE 4000	79L	Drop Down
SE 4300	76L	Pull-Strap
SE 4060	60L	Pull Down
SE 4400	35L	Drop Down

SE 4210B4 4 x Replacement 236ml Solution Bottles

SPECIAL ORDER: PLEASE QUOTE ITEM CODE UPON ORDERING THIS PRODUCT

FREE-STANDING PEDESTAL-MOUNTED EYEWASH STATION

- Manufactured from 304 stainless steel
- Twin aerated spray heads
- Hand and foot operated
- Stay open full flow ball valve
- Manufactured to comply to AS 4775:2007
- Flow rate: 12L/min



Item Code	Bishops Code
SE 546	55090640

AERATED EYE & FACE WASH UNITS

- Wall mount or free standing units
- 304 stainless steel
- Six aerated nozzle outlets
- Hand and foot operated
- Eye wash flow rate: 36L/min
- 136kPa minimum pressure
- Australian Manufactured to comply with AS4775



SE 400



SE 480

Item Code	Description	Mounting	Operation
SE 400	Eye & Face Wash Unit	Wall	Hand
SE 480	Eye & Face Wash Unit	Pedestal	Hand & Foot

SPECIAL ORDER: PLEASE QUOTE ITEM CODE UPON ORDERING THIS PRODUCT

STAINLESS STEEL PEDESTAL-MOUNTED EYEWASH STATION

- Free-standing unit complete with baseplate for floor-mounting
- Hand-operated
- Stainless steel bowl with green rubber aerator caps
- Flow of flushing water begins immediately
- Fitted with aerated diffusers and flow regulator
- Comes with complete maintenance and installation instructions
- Stay-on ball valve
- Optional foot treadle is available separately



Item Code	Bishops Code
H-STD85GSP	55090668

SAFETY SHOWER & EYEWASH UNITS

- Single aerated nozzle outlets on each side
- 130kPa minimum pressure
- Australian Manufactured to comply with AS4775



SE 582



SE 584HFO

SE 693HFO

Item Code	Description	Mounting	Operation	Flow Rate
SE 582	Eye Wash Unit	Wall	Hand	12L/Min
SE 584HFO	Eye Wash Unit	Pedestal	Hand & Foot	12L/Min
SE 693HFO	Shower & Eye Wash Unit	Pedestal	Hand & Foot	76L/Min (Shower) 20L/Min (Eye Wash)

SPECIAL ORDER: PLEASE QUOTE ITEM CODE UPON ORDERING THIS PRODUCT

SAFETY SHOWER & EYEWASH UNITS WITH AUTO-OPENING FLIP TOP COVER

- 304 stainless steel
- Flip-up lid keeps bowl and nozzles free from dirt, dust and other contaminants inbetween use
- Auto-opening flip top lid
- Single aerated nozzle outlets
- Eye wash flow rate: 12L/min
- Safety shower flow rate: 76/min
- Australian manufactured to comply with AS4775



SE 582FTL



SE 584HFOFTL



SE 693HFOFTL

Item Code	Description	Mounting	Operation
SE 582FTL	Eye Wash Unit	Wall	Hand
SE 584HFOFTL	Eye Wash Unit	Pedestal	Hand & Foot
SE 693HFOFTL	Shower & Eye Wash Unit	Pedestal	Hand & Foot

SPECIAL ORDER: PLEASE QUOTE ITEM CODE UPON ORDERING THIS PRODUCT

COMBINATION SAFETY SHOWER & EYEWASH

- Free-standing unit complete with baseplate for floor-mounting
- Stainless steel bowl and tubing
- Eyewash section has twin-spray nozzles with dust covers and is push-plate operated
- The eyewash diffusers are fitted with fine mesh strainers, and individual flow controllers are designed to give a gentle flow of aerated water
- The water jets lift off the dust covers when operated
- Stay-on ball valve
- Optional foot treadle and pictured signage available separately



Item Code	Bishops Code
H-EXP18GS85G	55090650

COMBINATION SAFETY SHOWER & EYEWASH

- Covered eyewash unit with integral lid, aerated diffusers, flow regulator and self-adhesive pictogram sign
- Hand-operated pull rod shower control
- Shower spray nozzle
- Stay-on ball valve
- Optional foot treadle and pictured signage available separately



Item Code	Bishops Code
H-EXP18GS45G	55090665

SELF-DRAINING COMBINATION SAFETY SHOWER & EYEWASH

- Designed for outdoor use
- Free-standing, complete with baseplate for floor mounting
- Stainless steel bowl and tubing
- The main shower valve is situated directly above the water inlet and is complete with bleed pipe to drain water from the stand
- Eyewash section has twin-spray nozzles with dust covers and is push-plate operated
- The eyewash diffusers are fitted with fine mesh strainers and individual flow controllers are designed to give a gentle flow of aerated water
- The water jets lift off the dust covers when operated
- Stay-on ball valve
- Optional foot treadle and pictured signage available separately



Item Code	Bishops Code
H-EXPSD18GS85G	55090667

SAFETY SHOWERS & AERATED EYE/FACE WASH UNITS

- Hand and foot operated
- Eye wash flow rate: 36L/min
- Shower flow rate: 76L/min
- Australian manufactured to comply with AS4775



Item Code	Description
SE 607	Safety Shower & Eye/Face Wash Unit
SE 685	Safety Shower & Eye/Face Wash Unit – No Bowl
SE 253	Free-Standing Safety Shower Unit

SPECIAL ORDER: PLEASE QUOTE ITEM CODE UPON ORDERING THIS PRODUCT

THERMAL RELIEF ANTI-SCALD VALVES FOR SAFETY SHOWERS

- Stainless steel body
- Reinforced flexible hose
- Designed for use on outdoor safety showers that are exposed to the sun
- Automatically bleeds off overheated water to allow cooler water to flow through
- Valve is sensitive to temperatures only and not air pressure
- Complies with AS4775.2007



Item Code	Description
SE 1/2 HAT SP 105 FF	Factory Fitted
SE 1/2 HAT SP 105 R	Retro Fit Kit Onsite
SE 1/2 HAT SP 105	Anti-Scald Valve Only

SPECIAL ORDER: PLEASE QUOTE ITEM CODE UPON ORDERING THIS PRODUCT

PRESSURISED STAINLESS STEEL TANK SAFETY WASH UNITS

- Trolleys sold separately



Item Code	Description	Capacity
SE 509	Personal Body/Eye Wash Unit	9L
SE 590-45	Eye Wash Unit	45L
SE 590A-106-695	Eye Wash & Body Spray Unit	106L

SPECIAL ORDER: PLEASE QUOTE ITEM CODE UPON ORDERING THIS PRODUCT



SPILL ABSORBENT PRODUCTS

SAFETY EQUIPMENT & CONSUMABLES

HEAVYWEIGHT GENERAL PURPOSE ABSORBENT PADS



- Heavy duty and dimpled for extra strength
- Absorbs oil/fuel and water based products
- Perfect for most jobs around the factory or site
- Dimensions: 500(l) x 400(w)mm
- 350gsm
- Grey
- 100 per pack



Item Code	Bishops Code
MOS-LMTX3602S	55080060

GENERAL PURPOSE ABSORBENT PADS



- Use to clean up a spill or wipe down tools and machinery
- Use to absorb most liquids including mild acids, bases, water, coolant, degreaser, paint, oil and fuels
- Medium duty, general purpose polypropylene absorbent pad
- Super absorbent, non-hazardous and non-allergenic
- Easy to use and will not degrade or chemically react with absorbed liquids
- Pad size: 450 x 450mm
- Colour: Grey



Item Code	Quantity	Absorption
SCM45M-50	50	Up to 57L Per Pack
SCM45M-100	100	Up to 114L Per Pack

SPECIAL ORDER: PLEASE QUOTE ITEM CODE UPON ORDERING THIS PRODUCT

GENERAL PURPOSE ABSORBENT PILLOWS



- Use to absorb and clean up large pooled spills
- Use to absorb all liquids including mild acids, bases, water, coolant, degreaser, paint, oil and fuels
- General purpose absorbent pillow made from compressed, meltblown polypropylene
- Super absorbent with high absorbency to weight ratio
- Easy to use and will not degrade or chemically react with absorbed liquids
- Non-hazardous, non-allergenic with little or no dust
- Colour: Grey



Item Code	Size	Absorption	Dimensions
SCM3422	Small	3.5L	340 x 220mm
SCM5837	Large	14L	580 x 370mm

SPECIAL ORDER: PLEASE QUOTE ITEM CODE UPON ORDERING THIS PRODUCT

GENERAL PURPOSE ABSORBENT BOOM



- Use to contain and clean up leaks, drips and spills in the workplace
- Clean up a spill or wipe down tools and machinery
- Use to absorb most liquids including mild acids, bases, water, coolant, degreaser, paint, oils and fuels
- General purpose absorbent mini boom with high absorbency to weight ratio
- Super absorbent, non-hazardous, non-allergenic and will not degrade or chemically react with absorbed liquids
- Absorb up to 7L per boom
- Dimensions: 1.2m x 7.5cm diameter
- Colour: Grey



Item Code
SCM12075

SPECIAL ORDER: PLEASE QUOTE ITEM CODE UPON ORDERING THIS PRODUCT

HEAVYWEIGHT OIL & FUEL ABSORBENT PADS



- Heavy duty 10mm compressed meltblown polypropylene pads
- Exceptional oil/fuel absorbency
- Reusable, easy to use
- Durable, non-allergenic, non-hazardous and dust-free
- Use in the rain or float on water to absorb oil and fuel only
- Ideal for maintenance and mine site workshops, vehicle repair shops, fuel and oil handling facilities
- Great for bilge and floor mop-up in ships, boats, naval and service vessels
- Dimensions: 500(l) x 400 (w)mm
- 350gsm
- White
- 100 per pack



Item Code	Bishops Code
BOS-LMTX3502SX	55080070

OIL & FUEL ABSORBENT PADS



- Absorb oil, fuel, diesel, petrol and other hydrocarbons
- Use to absorb and clean up leaks, drips and spills or for wiping down tools and machinery
- Manufactured from super absorbent polypropylene – non-hazardous and non-allergenic
- Super absorbent polypropylene is non-hazardous and non-allergenic
- Easy to use and will not degrade or chemically react with absorbed liquids
- Water repellent (hydrophobic) – can be used in and around water
- Colour: White



Item Code	Absorption	Pack Quantity	Size	Bishops Code
MBP-10	14L Per Pack	10	480 x 430mm	55080050
SCOF45S-50	35L Per Pack	50	450 x 450mm	*SCOF45S-50
SCOF45T-100	140L Per Pack	100	450 x 450mm	*SCOF45T-100

*** - SPECIAL ORDER: PLEASE QUOTE ITEM CODE UPON ORDERING THIS PRODUCT**

OIL & FUEL ABSORBENT ROLL

- Provides fast coverage over large areas
- Absorbs all known hydrocarbons
- Repels water and water-based liquids, perfect for protecting shorelines or river banks
- Absorbs up to 20 times its weight
- 200gsm
- Roll size: 1 x 50m



Item Code	Bishops Code
BR215	55080085

HEAVY DUTY OIL & FUEL ABSORBENT ROLL



- Absorbs oil, fuel, diesel, petrol and other hydrocarbons
- Use to absorb and clean up leaks, drips and spills or wipe down tools and equipment
- Heavy duty oil and fuel only absorbent roll
- Super absorbent polypropylene is non-hazardous and non-allergenic
- Easy to use and will not degrade or chemically react with absorbed liquids
- Water repellent (hydrophobic) – can be used in and around water
- Absorb 344L per roll
- Dimensions: 50(l)m x 1(w)m
- Colour: White



Item Code
SCOF50T

SPECIAL ORDER: PLEASE QUOTE ITEM CODE UPON ORDERING THIS PRODUCT

OIL & FUEL ABSORBENT PILLOW

- Suitable for placing under machinery and drums leaking oils and fuels
- Repels water
- Size: 450 x 450mm
- Sold individually



Item Code	Bishops Code
DB206	55080072

OIL & FUEL ABSORBENT PILLOWS



- Absorbs oil, fuel, diesel, petrol and other hydrocarbons
- Use to absorb and clean up large pooled spills
- Large oil and fuel absorbent pillow made from compressed, meltblown polypropylene
- Super absorbent with high absorbency to weight ratio
- Water repellent (hydrophobic) – can be used in and around water
- Easy to use and will not degrade or chemically react with absorbed liquids
- Non-hazardous and non-allergenic with little or no dust
- Absorbs up to 14L per pillow
- Dimensions: 580 x 370mm
- Colour: White



Item Code	Bishops Code
SCOF5837	55080082

SPECIAL ORDER: PLEASE QUOTE ITEM CODE UPON ORDERING THIS PRODUCT

OIL & FUEL FLOATING ABSORBENT BOOMS

- Absorbs oils, fuels and other hydrocarbons
- Repels water, making it ideal for rivers, creeks, canals and other marine environments
- Doubled outer layer for extra durability



Item Code	Size	Pack Qty	Bishops Code
FB201/4	200mm x 3m	4	55080090
FB214/2	200mm x 6m	2	55080095

OIL & FUEL ABSORBENT BOOMS



- Absorbs oil, fuel, diesel, petrol and other hydrocarbons
- Use to contain, divert and clean up leaks, drips and spills in the workplace
- Oil and fuel only absorbent mini boom with high absorbency to weight ratio
- Super absorbent, non-hazardous, non-allergenic and will not degrade or chemically react with absorbed liquids
- Water repellent (hydrophobic) – can be used in and around water
- Colour: White



Item Code	Absorption	Dimensions	Bishops Code
SCOF12075	7L	1.2m x 7.5cm	55080096
SCOF30075	18L	3.0m x 7.5cm	55080087

HAZCHEM ABSORBENT PADS



- Absorb spills of hazardous chemicals/liquids
- Hazchem polypropylene absorbent pad with high absorbency to weight ratio
- Super absorbent, non hazardous and non-allergenic
- Easy to use and will not degrade or chemically react with absorbed liquids
- Colour: Pink



Item Code	Description	Absorption	Pack Qty	Size	Bishops Code
SCH45S-50	Standard Duty	33L Per Pack	50	450 x 450mm	55080080
SCH41T-50	Heavy Duty	70L Per Pack	50	400 x 500mm	55080082

HAZCHEM ABSORBENT ROLL

- Provides fast coverage over large areas
- Absorbs up to 20 times its weight of acids, caustics, alkalis, oils and fuels
- Meets EPA requirements
- 400gsm
- Roll size: 50mm x 50m



Item Code	Bishops Code
EBR309	55080086

HAZCHEM ABSORBENT PILLOW



- Absorb spills of hazardous chemicals/liquids
- Hazchem absorbent polypropylene pillow with high absorbency to weight ratio
- Super absorbent, non-hazardous and non-allergenic
- Will not degrade or chemically react with absorbed liquids
- Absorbs 3.4L per pillow
- Dimensions: 340 x 220mm
- Colour: Pink



Item Code	Bishops Code
SCH3422	55080084

HAZCHEM ABSORBENT MINI BOOM



- Use to contain, divert and clean up leaks, drips and spills of hazardous chemicals in the workplace or form an absorbent barrier around drums, vehicles and machinery
- Hazchem absorbent polypropylene mini boom with high absorbency to weight ratio
- Super absorbent, non hazardous and non-allergenic
- Will not degrade or chemically react with absorbed liquids
- Absorbs 7L per boom
- Dimensions: 1.2m x 7.5cm diameter
- Colour: Pink



Item Code	Bishops Code
SCH12075	55080096

SPECIAL ORDER: PLEASE QUOTE ITEM CODE UPON ORDERING THIS PRODUCT



ABSORBENT SWEEP, DRAIN COVERS & WIPES

SAFETY EQUIPMENT & CONSUMABLES

HAZCHEM ABSORBENT BOOMS

- Absorbs acids, caustics, alkalis, oils and fuels
- Can absorb up to 20 times its weight
- Meets EPA requirements
- Blue



Item Code	Size	Bishops Code
EMB12100	75mm x 1.2m	55080097
EMB30100	75mm x 3.0m	55080098

FLOORSWEEP PREMIUM BIOACTIVE ABSORBENT

- Premium cellulose absorbent
- Encapsulates oil spills and breaks down hydrocarbons
- Advanced compound for rapid absorption
- Unlike other absorbent, does not contain crystalline silica which is harmful to humans
- Environmentally friendly
- Safe for landfill
- 10kg bag



Item Code	Bishops Code
FS10KG	55080369

BUDGETSORB FLOORSWEEP

- General purpose floorsweep for concrete and hard surfaces
- Absorbs oil, fuel, acids, bases, coolants, paint, solvents and chemicals
- Made from a 100% renewable resource – a blend of coir peat and cellulose based organics
- 100% organic and biodegradable
- Non-abrasive and non-leaching – organic fibre will not discharge absorbed pollutants
- Fast wicking action – ideal for placing on and around a spill to solidify and absorb before sweeping up



Item Code	Size	Absorption	Bishops Code
BSB20L	20L/3.6kg	Up to 11L Per Bag	55080355
BSB50L	50L/9kg	Up to 27L Per Bag	55080360

HAZCHEM ABSORBENT PARTICULATE

- Absorb acids, bases, coolants, paint, solvents, oil and hazardous chemicals
- Ideal for placing on and around a spill to solidify and absorb
- Compressed meltblown polypropylene loose absorbent fibre
- Super absorbent, non-leaching, non-hazardous and non-allergenic with high absorbency to weight ratio
- Easy to use and will not degrade or chemically react with absorbed liquids
- Absorb up to 50L per bag
- Bag size: 2.5kg
- Colour: Pink



Item Code
SCHPC

SPECIAL ORDER: PLEASE QUOTE ITEM CODE UPON ORDERING THIS PRODUCT

DRAIN WARDEN WITH PILLOW



- Capture solids, silt and oils in stormwater drains
- Place below a stormwater drain grate to minimise or prevent hydrocarbons/sediment from entering the drain
- Heavy duty 200 micron geotextile fabric with integral flow bypass (for periods of high flow)
- Contains an oil and fuel absorbent pillow which is hydrophobic (water repellent) – can absorb up to 14L of oil
- Suitable for drains up to 1m² – fabric is cut to suit drain size or shape
- Additional or replacement pillows can be ordered separately (Item Code: SCOF5837)



Item Code
ST12

SPECIAL ORDER: PLEASE QUOTE ITEM CODE UPON ORDERING THIS PRODUCT

DRAIN COVERS



- Prevent spills from entering drains
- Heavy duty urethane construction
- Flexible, 'sticky' urethane which moulds to even and uneven surfaces
- Provides protection for a wide range of chemicals and hydrocarbons
- Includes bright yellow 'Canvacon' carry/storage bag with velcro closure
- Protectors are easily cleaned, stored and available to reuse
- Choose a size that overlaps your drain grate by at least 10cm
- Do not leave in direct heat for long periods of time



Item Code	Size
UDP600	0.6m x 0.6m
UDP900	0.9m x 0.9m
UDP1200	1.2m x 1.2m

SPECIAL ORDER: PLEASE QUOTE ITEM CODE UPON ORDERING THIS PRODUCT

WORKTUFF ALL PURPOSE WIPES



- Tough construction so they won't fall apart, even after absorbing six times their weight in liquid
- Clean up most liquids including coolant, degreaser, fuels, oils, grease or even water
- Ideal for cleaning hydraulic hoses, fuel lines, pipes, fittings, equipment, machinery, tools, work benches and hands
- Tough, durable and super absorbent polypropylene wipe
- Lint-free
- Size: 300 x 300mm
- 50 per pack



Item Code
GAPW

SPECIAL ORDER: PLEASE QUOTE ITEM CODE UPON ORDERING THIS PRODUCT

GET MORE AT BISHOPS



BAG OF RAGS

Page 403

GENERAL PURPOSE 30L VEHICLE SPILL KIT



- Suitable to absorb all liquids including coolant, oil, fuel, degreaser, paint, blood and mild acids
- Stows easily in vehicles behind seats, in trailers, work trucks, cabs and trays

Includes:

- 1 x Grey General Purpose Absorbent Mini Boom – 1.2m x 7.5cm
- 10 x Spill Crew Grey General Purpose, Medium Duty, Absorbent Pads – 45 x 45cm
- 1 x Pair Red Gauntlet PVC Gloves – 450mm long (EN388 3121 rating)
- 2 x Polyethylene Contaminated Waste Disposal Bags – 100micron
- 1 x 500g Drum Seal
- 1 x Blue PVC Carry Bag



Item Code	Bishops Code
SKGPMT-CS1	55080006

GENERAL PURPOSE 120L PREMIUM SPILL KIT



- Suitable to absorb all liquids including coolant, oil, fuel, degreaser, paint, blood, mild acids
- Ideal for indoor and outdoor – workshops, laundries, hospitals, water treatment plants

Includes:

- 3 x Grey General Purpose Absorbent Mini Boom – 1.2m x 7.5cm
- 1 x Grey General Purpose Absorbent Mini Boom – 2.4m x 7.5cm
- 1 x 50 Pack Grey General Purpose Low Lint Absorbent Pads – 45 x 45cm
- 1 x 50L Bag Budgetsorb Floorsweep Absorbent
- 5 x Polyethylene Contaminated Waste Disposal Bags – 100micron
- 1 x Pair Red Gauntlet PVC Gloves – 450mm long (EN388 3121 rating)
- 1 x 120L Wheelie Bin – Sky Blue
- 1 x General Purpose Front Label
- 1 x A4 Spill Kit Instructions



Item Code	Bishops Code
SKGP120-CS1	55080000

GENERAL PURPOSE 240L SPILL KIT



- Suitable to absorb all liquids including coolant, oil, fuel, degreaser, paint, blood and mild acids
- Ideal for indoor and outdoor – workshops, laundries, hospitals, water treatment plants

Includes:

- 40 x Grey General Purpose Low Lint Absorbent pads – 45 x 45cm
- 3 x Grey General Purpose Absorbent Mini Booms – 1.2m x 7.5cm
- 1 x Grey General Purpose Absorbent Mini Booms – 2.4m x 7.5cm
- 3 x General Purpose Absorbent Pillows – 34cm x 22cm
- 3 x 50L Bags Budgetsorb Floorsweep
- 1 x Pair Red Gauntlet PVC Gloves – 450mm long (EN388 3121 rating)
- 5 x Polyethylene Contaminated Waste Disposal Bags – 100micron
- 1 x Audit Tag
- 1 x 240L Wheelie Bin – Sky Blue
- 1 x PVC Wheelie Bin instruction Sheet Holder
- 1 x A4 Spill Kit Instructions
- 1 x General Purpose Front Label



Item Code	Bishops Code
SKGPB240-CS1A	55080002

OIL & FUEL 50L LIGHT VEHICLE SPILL KIT



- Suitable to absorb oil, fuel, diesel, petrol, solvents and other petroleum products
- Stows easily in vehicles behind seats, in trailers, work trucks, cabs and trays

Includes:

- 20 x White Oil & Fuel Standard Duty Pads – 45 x 45cm
- 1 x White Oil & Fuel Absorbent Mini Boom – 1.2m x 7.5cm
- 1 x 8L Bag Global Peat Oil & Fuel Absorbent
- 1 x Polyethylene Contaminated Waste Disposal Bag – 100micron
- 1 x Pair Red Gauntlet PVC Gloves – 450mm long (EN388 3121 rating)
- 1 x A4 Spill Kit Instructions
- 1 x Yellow PVC Carry Bag – 660 x 1,025mm



Item Code	Bishops Code
SKHMT-CS	55080004

OIL & FUEL 50L SMALL TRUCK SPILL KIT



- Suitable to absorb oil, fuel, diesel, petrol, solvents and other petroleum products
- Ideal for unsealed areas in and around mine sites, drilling rigs and workshops

Includes:

- 50 x White Oil & Fuel Standard Duty Pads – 45 x 45cm
- 3 x White Oil & Fuel Absorbent Mini Booms – 1.2m x 7.5cm
- 2 x Small White Oil & Fuel Absorbent Pillows – 34 x 22cm
- 1 x Pair Red Gauntlet PVC Gloves – 450mm long (EN388 3121 rating)
- 3 x Polyethylene Contaminated Waste Disposal Bags – 100micron
- 1 x A4 Spill Kit Instructions
- 1 x Yellow PVC Carry Bag – 660 x 1,475mm



Item Code	Bishops Code
SKHMDT-CS1	55080005

OIL & FUEL 120L SPILL KIT



- Suitable to absorb oil, fuel, diesel, petrol, solvent and other petroleum products
- Ideal for sealed surfaces in and around workshops, warehouses or loading docks

Includes:

- 2 x White Oil & Fuel Absorbent Mini Booms – 1.2m x 7.5cm
- 1 x Small White Oil & Fuel Absorbent Pillows – 34 x 22cm
- 20 x White Heavy Duty Oil & Fuel Pads – 45 x 45cm
- 2 x 20L Bags Budgetsorb General Purpose Absorbent Floorsweep
- 7 x Polyethylene Contaminated Waste Disposal Bags – 100micron
- 1 x Pair Red Nitrile Gloves – 33cm (Size 9)
- 1 x Dustpan & Nylon Brush
- 1 x 120L Yellow Wheelie Bin
- 1 x A4 Spill Kit Instructions



Item Code	Bishops Code
SKH120-CS4	55080001



SPILL KITS

MARINE 190L SPILL KIT



- Suitable to absorb oil, fuel, diesel, petrol, solvents and other petroleum products
- Ideal for harbours, ponds, ports, marinas or inland waterways
- Absorbent capacity: Up to 190L

Includes:

- 10 x Heavy Duty Oil & Fuel Pads
- 3 x Bilge Socks
- 2 x Oil & Fuel Marine Booms
- 1 x Heavy Duty Oil & Fuel Absorbent Roll
- 2 x Pairs Red PVC Gloves
- 3 x Audit Tags
- 10 x Disposable Contaminated Waste Bags
- 1 x Spill Kit Lid Cover



Item Code	Bishops Code
SKM240-CS1	55080045

OIL & FUEL 240L SPILL KIT



- Suitable to absorb oil, fuel, diesel, petrol, solvent and other petroleum products
- Ideal for sealed surfaces in and around workshops, warehouses or loading docks

Contents

- Includes: x 50 Pack White Oil & Fuel Standard Duty Pads – 45 x 45cm
- 4 x White Oil & Fuel Absorbent Mini Booms – 1.2m x 7.5cm
- 1 x Large White Oil & Fuel Absorbent Pillow – 58 x 37cm
- 2 x 28L Bags Global Peat Oil & Fuel Floor Absorbent
- 4 x Pairs Red Gauntlet PVC Gloves – 450mm long (EN388 3121 rating)
- 5 x Polyethylene Contaminated Waste Disposal Bags & Ties – 100micron
- 5 x Cable Ties
- 1 x Dustpan & Nylon Brush
- 1 x A4 Spill Kit Instructions
- 1 x 240L Wheelie Bin – Yellow



Item Code	Bishops Code
SKH240-CS11	55080003

HAZCHEM 20L SPILL KIT



- Suitable to absorb acids, bases, coolants, solvents, oils, fuels and hazardous chemicals
- Ideal for vehicles, workshops, warehouses, factories and laboratories

Includes:

- 1 x Pink Hazchem Absorbent Mini Boom – 1.2m x 7.5cm
- 1 x Contaminated waste disposal bag, polyethylene – 100micron
- 10 x Pink Standard Duty Hazchem Absorbent Pads – 45 x 45cm
- 1 x Pair Red Gauntlet PVC Gloves – 450mm long (EN388 3121 rating)
- 1 x Red PVC Carry Bag with Label – 660 x 1,025mm



Item Code	Bishops Code
SKCMT-CS1	55080024

HAZCHEM 240L HIGH PERFORMANCE SPILL KIT



- Suitable to absorb acids, bases, coolants, solvents, oils, fuels, and hazardous chemicals
- Ideal for workshops, warehouses, factories, chemical plants and laboratories

Includes:

- 3 x Pink Hazchem Absorbent Mini Boom – 1.2m x 7.5cm
- 1 x Pink Hazchem Absorbent Mini Boom – 2.4m x 7.5cm
- 2 x 50 Packs Pink Hazchem Standard Duty Absorbent Pads – 45 x 45cm
- 2 x 2.5kg Bags Pink Polypropylene Hazchem Absorbent Particulate
- 1 x Pair Nitrile Gloves – 33cm (Size 9)
- 1 x Chemmax1Type 3-4 Coverall – X-Large
- 1 x 500g Drum Seal
- 1 x Safety Goggles
- 10 x Polyethylene Contaminated Waste Disposal Bags – 100micron
- 1 x 240L Wheelie Bin – Red
- 3 x Audit Tags
- 1 x A4 Spill Kit Instructions



Item Code	Bishops Code
SKC240-CS1	55080042

CONTAMINATED WASTE BAGS

- Heavy duty bags made from chemical resistant polyethylene
- To be used at the end of the spill clean up procedure
- Comes with cable ties to secure the contents of each bag
- 560(l) x 700(w)mm
- Thickness: 150µm
- 10 per pack



Item Code	Bishops Code
X-BAT10	55080365

GET MORE AT BISHOPS



GENERAL RUBBISH BINS

Page 409



VORTEX HIGH TEMPERATURE INFERNO

- Use to incinerate used absorbents, oily waste, filters and other combustible waste
- High temperature incinerator for absorbents, greasy rags, oil and fuel filters, office waste, food service waste, packing material and non infectious waste
- Incinerated waste can be safely sent to landfill for disposal
- Design based on the 3Ts principle – Time, Turbulence and Temperature
- Small and portable with stainless steel frame
- 240V electric blower with RCD protection and flow control valve
- Includes air lance with adjustable air flow control valve
- Includes drum grate (supplied loose) to fit a standard 205L open head drum
- One person only required to load and operate the unit
- 99% smoke, ash and pollution free (emission test report available upon request)
- Flue extender sold separately

Flue Extender:

- Extend the flue of the incinerator secondary chamber outlet
- Stainless steel construction
- 900mm long x 250mm diameter
- Inferno sold separately



CSSVI-1

Item Code	Description
CSSVI-1	Vortex High Temperature Inferno
CSSVI-F	Flue Extender

SPECIAL ORDER: PLEASE QUOTE ITEM CODE UPON ORDERING THIS PRODUCT

GET MORE AT BISHOPS



CHEMICAL RESISTANT GLOVES

Page 10

DRIP TRAYS

- Perfect for janitorial storage rooms and automotive workshops
- Made of polyethylene for excellent chemical resistance



Item Code	Description	Capacity	Size	Bishops Code
TSSDTM	Medium	20L	520(l) x 360(w) x 80(h)mm	55080250
TSSDTL	Large	45L	810(l) x 610(w) x 100(h)mm	55080260

STORAGE TRAYS

- Provides safe, banded storage drums and containers
- Ribbed base design provides additional strength and spill clearance
- Made from chemical resistant rotomoulded polyethylene for superior durability
- No grate



55080272

Item Code	Description	Capacity	Size	Bishops Code
TSSGPT1	Medium	110L	730(l) x 730(w) x 295(h)mm	55080270
TSSGPT2	Large	230L	1,290(l) x 730(w) x 295(h)mm	55080272

DRUM OVERPACKS

- Made of high-density yellow polyethylene
- Tool-free screw-down closure with gasket lid for positive seal
- Weatherproof with UV inhibitors
- Nestable for convenient storage
- Approved for use with Packaging Group I, II and III
- Certified for use as DOT salvage drums 49 CFR 173.3(c)
- UL 94HB flammability rating
- FDA 21 CFR 177.1520 food grade
- Capacity: 360L



Item Code	Bishops Code
TSS1237	55080130

PORTABLE WASH PAD

- 900gsm PVC material
- Compact and portable wash pad
- Foam-filled ends allow for easy drive-through
- Open size: 3 x 6m
- Folded size: 600 x 800 x 350mm
- Weight (dry): 20kg



Item Code	Bishops Code
TSSWPS	55080398

STANDARD DUTY COLLAPSIBLE BUNDS



- Pop-up portable bund to create a safe and secure spill containment area to capture drips, leaks or spills
- Use to store drums, IBCs, machinery or vehicles
- Externally mounted wall braces permit the walls to be quickly collapsed for access
- Rapid set up and set down
- Ideal for use as a washpad for vehicles, plant or machinery
- Standard duty 900gsm orange PVC
- Compatible with oil, diesel and a range of chemicals (refer to GSC for specific compatibility)
- Supplied with carry/storage bag



SCCB2.4x2.4-SD

Item Code	Size	Bishops Code
SCCB2.4x2.4-SD	2.4 x 2.4m	*SCCB2.4x2.4-SD
SCCB3.6x2.4SD	3.6 x 2.4m	55080390
SCCB6.8x3.2SD	6.8 x 3.2m	55080395

*** - SPECIAL ORDER: PLEASE QUOTE ITEM CODE UPON ORDERING THIS PRODUCT**



SPILL BUNDS & PALLETS

SAFETY EQUIPMENT & CONSUMABLES

HEAVY DUTY COLLAPSIBLE BUNDS

Global Spill & Safety



- Pop-up portable bund to create a safe and secure spill containment area to capture drips, leaks or spills
- Use to store drums, IBCs, machinery or vehicles
- Externally mounted wall braces permit the walls to be quickly collapsed for access to the bund
- Rapid set up and set down
- Ideal for use as a washpad for vehicles, plant or machinery
- Manufactured from heavy duty 1,350gsm black PVC
- Compatible with oil, diesel and a range of chemicals (refer to GSC for specific compatibility)
- Supplied with carry/storage bag



SCCB3 2X2-HD

Item Code	Size	Bishops Code
SCCB2.4X1.2HD	2.4 x 1.2m	55080380
SCCB3.2X2-HD	3.2 x 2m	55080385

2 DRUM SPILL CONTAINER



- Compatible with most forklifts and pallet trucks
- Helps to create an OH&S compliant workplace
- Non-skid removable deck
- Suits 205L drums
- Sump capacity: 236L
- Dimensions: 750(l) x 1,300(w) x 440(h)mm
- Weight: 20kg



Item Code	Bishops Code
SJ-100-002	55080136

STACKABLE 4 DRUM SPILL CONTAINER



- Compatible with most forklifts and pallet trucks
- Helps to create an OH&S compliant workplace
- Suits 205L drums
- Non-skid removable deck
- Sump capacity: 236L
- Dimensions: 1,460(l) x 1,460(w) x 305(h)mm
- Weight: 37kg



Item Code	Bishops Code
SJ-110-006	55080136

2 DRUM BUNDED PALLET



- Can store up to 2 x 205L drums
- Spill capacity: 230L – exceeds Australian Standards
- Corrosion resistant
- Pallet truck and forklift friendly
- Unique spill gutter – immediately identify if a product is leaking as the liquid flows to the edges
- Removable, non-slip, heavy-duty fibreglass grate
- UV stable heavy-duty poly construction
- Nestable for transport
- 1,290(l) x 860(w) x 440(h)mm
- SWL: 500kg
- Weight: 28kg



Item Code	Bishops Code
MXP1001	55080138

4 DRUM BUNDED PALLET



- Can store up to 4 x 205L drums
- Spill capacity: 230L – exceeds Australian Standards
- Corrosion resistant
- Pallet truck and forklift friendly
- Unique spill gutter – immediately identify if a product is leaking as the liquid flows to the edges
- Removable, non-slip, heavy-duty fibreglass grate
- UV stable heavy-duty poly construction
- Nestable for transport
- 1,290(l) x 1,290(w) x 250(h)mm
- SWL: 1,000kg
- Weight: 33kg



Item Code	Bishops Code
MXP1002	55080138

ROLL TOP DRUM SPILL PALLET

- Rotomoulded from 100% polyethylene
- Removable non-slip grates
- Lockable for extra security
- Can be moved with a forklift when loaded
- Meets EPA requirements
- Holds 4 x 205L drums
- Sump capacity: 410L
- 1,450(l) x 1,400(w) x 2,070(h)mm
- Comes flat packed



Item Code	Bishops Code
TSSBP4RT	55080136

POLYETHYLENE SPILL PALLETS

Global Spill & Safety



- Heavy duty Australian Made storage bund to capture leaks, drips and spills
- Manufactured from chemical resistant polyethylene for corrosion resistance to oils, fuels and most chemicals
- Removable polypropylene grated tops – allows easy access for draining or cleaning
- Built-in spill containment sump
- Load tested in Australia by NATA accredited engineers – dynamic compression test certificate(s) available



Item Code	Drum Capacity	Max. UDL	Sump Capacity	Dimensions	Bishops Code
DB2G	2 x 205L	1,100kg	246L	123(l) x 64(w) x 51.5(h)cm	55080100
DB3G	3 x 205L – In-Line	1,100kg	250L	182(l) x 63(w) x 35(h)cm	*DB3G
DB4G	4 x 205L	2,800kg	242L	123(l) x 123(w) x 28(h)cm	55080120
DB4GIL	4 x 205L – In-Line	2,800kg	245L	242(l) x 62(w) x 25.2(h)cm	*DB4GIL

SPILL PALLET COVERS					
COVS-DB2G	Cover to Suit 2 Drum Spill Pallet				55080142
COVS-DB4G	Cover to Suit 4 Drum Spill Pallet				55080138

* – SPECIAL ORDER: PLEASE QUOTE ITEM CODE UPON ORDERING THIS PRODUCT

SINGLE IBC BUNDED PALLET

- Stores 1 x 1,000L IBC
- Spill capacity: 1,150L – exceeds Australian Standards
- Corrosion resistant
- Pallet truck and forklift friendly
- Anti-slip, heavy duty FRP grating
- Low profile, zero 'pooling' area for dangerous chemicals
- Super heavy-duty polyethylene construction for harsh climates
- Solid tapered lip for maximum rigidity and longevity
- Nestable for transport
- 1,760(l) x 1,350(w) x 800(h)mm
- SWL: 1,650kg
- Weight: 107kg



Item Code	Bishops Code
MXP6001	55080146

DOUBLE IBC BUNDED PALLET

- Stores 2 x 1,000L IBC
- Spill capacity: 1,300L – exceeds Australian Standards
- Corrosion resistant
- Pallet truck and forklift friendly
- Anti-slip, heavy duty FRP grating
- Low profile, zero 'pooling' area for dangerous chemicals
- Super heavy-duty polyethylene construction for harsh climates
- Solid tapered lip for maximum rigidity and longevity
- Nestable for transport
- 2,550(l) x 1,350(w) x 580(h)mm
- SWL: 3,200kg
- Weight: 116kg



Item Code	SPECIAL ORDER: PLEASE QUOTE ITEM CODE UPON ORDERING THIS PRODUCT
MXP6002	

POLYETHYLENE IBC SPILL PALLETS

- Heavy duty Australian made storage bund to capture leaks, drips and spills
- Manufactured from chemical resistant polyethylene for corrosion resistance to oils, fuels and most chemicals
- Includes drain plugs in sump
- Forklift pockets for easy relocation
- Load tested in Australia by NATA accredited engineers – dynamic compression test certificate(s) available



Item Code	Capacity	Max. UDL	Sump Capacity	Dimensions	Bishops Code
DBSIBC	1 x 1,000L IBC	2,000kg	1,150L	190(l) x 150(w) x 75(h)cm	55080148
DBDIBC	2 x 1,000L IBC	3,600kg	1,470L	278(l) x 148(w) x 66(h)cm	*DBDIBC

* – SPECIAL ORDER: PLEASE QUOTE ITEM CODE UPON ORDERING THIS PRODUCT

IBC SPILL PALLET COVERS

- Allows IBC tanks to be safely stored outdoors while protecting the load and the sump from rainwater
- Made from welded heavy duty coated PVC
- Elastic shock cord keeps cover in place
- Easily removable when access is required



Item Code	Description	Bishops Code
TSSBB1C	Single IBC Spill Pallet Cover	55080132
TSSBB2C	Dual IBC Spill Pallet Cover	55080134

2 DRUM BUND PVC COVER & GALVANISED FRAME

- Cover and frame to suit 2 drum bund
- Heavy-duty UV stabilised PVC
- Flat packs for transport
- Easy to assemble
- Tonneau bars to support the roof during heavy rainfall and prevent pooling
- Double zip offers easy access for loading and unloading
- Camlock straps to secure the PVC cover to the frame
- Galvanised steel frame
- Bund not included
- Height: 1,300mm



Item Code	SPECIAL ORDER: PLEASE QUOTE ITEM CODE UPON ORDERING THIS PRODUCT
MXP6501	

4 DRUM BUND PVC COVER & GALVANISED FRAME

- Cover and frame to suit 4 drum bund
- Heavy-duty UV stabilised PVC
- Flat packs for transport
- Easy to assemble
- Tonneau bars to support the roof during heavy rainfall and prevent pooling
- Double zip offers easy access for loading and unloading
- Camlock straps to secure the PVC cover to the frame
- Galvanised steel frame
- Bund not included
- Height: 1,300mm



Item Code	SPECIAL ORDER: PLEASE QUOTE ITEM CODE UPON ORDERING THIS PRODUCT
MXP6502	

SINGLE IBC BUND PVC COVER & GALVANISED FRAME

- Cover and frame to suit single IBC bund
- Heavy-duty UV stabilised PVC
- Rigid tonneau bars to support roof during heavy rainfall and stop it pooling
- Double full length zippers ensure easy access to the bund while providing a weather proof seal
- Robust design galvanised RHS frame to contend with tough exterior conditions
- Easy to assemble
- Camlock straps to secure the PVC cover to the frame
- Internal dimensions: 1,700(l) x 1,300(w) x 1,640(h)mm
- Bund not included
- 38kg



Item Code	SPECIAL ORDER: PLEASE QUOTE ITEM CODE UPON ORDERING THIS PRODUCT
MXP6503	

DOUBLE IBC BUND PVC COVER & GALVANISED FRAME

- Cover and frame to suit double IBC bund
- Heavy-duty UV stabilised PVC
- Rigid tonneau bars to support roof during heavy rainfall and stop it pooling
- Double full length zippers ensure easy access to the bund while providing a weather proof seal
- Robust design galvanised RHS frame to contend with tough exterior conditions
- Easy to assemble
- Camlock straps to secure the PVC cover to the frame
- Internal dimensions: 2,300(l) x 1,300(w) x 1,640(h)mm
- Bund not included
- 40kg



Item Code	SPECIAL ORDER: PLEASE QUOTE ITEM CODE UPON ORDERING THIS PRODUCT
MXP6504	



FIRE EXTINGUISHER GUIDE

Colour	Type	Class						Comments
		A	B	C	D	E	F	
	Water	✓	✗	✗		✗	✗	Dangerous if used on flammable liquid, energised electrical equipment and cooking oil/fat fires.
	Wet Chemical	✓	✗	✗		✗	✓	Dangerous if used on energised electrical equipment.
	Foam	✓	✓	✗		✗	☹	Dangerous if used on energised electrical equipment.
	Powder ABE	✓	✓	✓		✓	✗	Look carefully at the extinguisher to determine if it is a BE or ABE Powder BE unit as the capability is different.
	Powder BE	✗	✓	✓		✓	✓	
	Carbon Dioxide	☹	☹	✗		✓	✗	Not suitable for outdoor use or smouldering deep seated A Class fire.
	Vaporising Liquid	✓	☹	☹		✓	✗	Check the characteristics of the specific extinguishing agent. 5 yearly servicing must be done by ODS & SGG licensed persons.
	Fire Blanket	☹	☹	✗		✗	✓	Fire Blankets may be used as a thermal barrier against radiated heat and to control a fire on clothes being worn by a person.

Use only special purpose extinguishers and seek expert advice.

- Class A** = Wood, Paper, Plastic
- Class B** = Flammable & Combustible Liquids
- Class C** = Flammable Gases
- Class D** = Metal Fire
- Class E** = Electrically Energised Equipment
- Class F** = Cooking Oils & Fats

- ✓ the class or classes in which agent is most effective
- ✗ not recommended for these class of fires
- ☹ indicates that the Extinguishant is not the agent of choice for the class of fire, but it may have a limited extinguishing capability
- ☹☹ solvents such as alcohol or acetone mix with water and therefore require special foam



DONT FORGET THE PASS WORD

- P**ull the pin
- A**im low at the base of the fire
- S**queeze the handle to spray the fire
- S**weep from side to side at the base of the fire until extinguished

FIRE BLANKET

- Blankets consist of a woven fibreglass fire resistant fabric
- Single use only
- Designed to fight a variety of stove top fires from fat and cooking oils, as well as clothing fires
- Can be kept in the kitchen, caravan or boat
- Blanket size: 1.2 x 1.8m
- Complies with:
 - AS/NZS 3504



Item Code	Bishops Code
EFB-12	55090304

ABE TYPE FIRE EXTINGUISHERS

- Dry Chemical Powder (DCP)
- Multi-purpose extinguishers, suitable to use on fires involving wood, cloth, paper, combustible liquids, electrical equipment and more
- Not recommended for use on fat fires in the kitchen



Size	Bishops Code	Size	Bishops Code
1kg	55090306	4.5kg	55090310
2.5kg	55090308	9kg	55090320

FOAM FIRE EXTINGUISHER

- Rating 3A: 20B
- Fitted with a shock-absorbing base for extra strength and safety
- Suitable for wood, paper and plastic fires (type A fires), flammable and combustible liquids (type B fires) and cooking oils and fats (type F fires – limited)
- Dangerous if used on electrical fires



Size	Bishops Code
9L	55090360

CO₂ FIRE EXTINGUISHER

- Lightweight aluminium alloy cylinder
- Transport style pull-out pin
- Forged brass head
- Complies to standards AS 1841.6
- Recommended for Class E electrical hazard fires, but also has limited capabilities for extinguishing small, indoor Class A paper and Class B flammable liquid fires



Size	Bishops Code
5kg	55090365

FIRE EXTINGUISHER BRACKETS

- Designed to safely secure a fire extinguisher to a vehicle or wall



55090382



55090325

Description	Bishops Code
Heavy Duty – Suit 2.5kg to 4.5kg Extinguisher	55090382
Heavy Duty – Suit 9kg Extinguisher	55090325

FIRE EXTINGUISHER COVERS

- Designed to protect fire extinguishers in harsh and dusty environments
- Also suitable for use outdoors
- Maximum UV resistance



Description	Bishops Code
To Suit 1.0kg & 1.5kg Extinguishers	55090340
To Suit 2.5kg & 4.5kg Extinguishers	55090345
To Suit 9.0kg Extinguishers	55090350

FIRE HOSE REEL

- Comes with chrome brass spray jet nozzle
- Hose size: 36m x 19mm



Item Code	Bishops Code
EA36HR	55090300

FIRE HOSE REELS, CABINETS & ACCESSORIES

AUSTRALIAN STANDARD HOSE REELS

Applications:

- Fire hose reels are designed to be used as a first response action method which any member of the community can use
- They are suitable for Class A fires

Features:

- Factory assembled with 36m x 19mm hose
- Twist operation brass hose nozzle
- Waterway gooseneck to prevent the hose from collapsing when wound onto the reel
- Corrosion-resistant waterway
- Watermark certified stop valve
- Conforms to AS/NZS 1221:1997

HOSE REEL CABINETS

Applications:

- A fire hose reel cabinet is designed to assist with the prevention of damage, deterioration, and vandalism of a fire hose reel

Features:

- Comply to Australian standards
- Designed with building contractors requirements in mind for good presentation, space-saving, and functional design
- Easy to install with connections to hose reel inlet



Stainless Steel Hose Reel



Fixed Hose Reel



Hose Reel Cabinet



Fixed Hose Reel Cabinet



Hose Reel Cover



Hose Reel Sign



SPECIAL ORDER: CONTACT YOUR BISHOPS REPRESENTATIVE FOR MORE INFORMATION & TO ORDER THESE PRODUCTS

NOZZLES

Applications:

- A wide variety of nozzles are suitable for water service within many environments such as marine, mining, industrial, and manufacturing from high-pressure washdown to fire protection

Features:

- Power jet twist spray nozzles
- Refinery fog nozzles
- Size range 3/4" to 1 1/2"
- Female pipe thread suitable for BSP or NPT
- FM approved options available

Materials:

- Polycarbonate
- Brass
- Thermoplastic
- Rubber gasket to create a pressure-type seal



Polycarbonate Nozzles



SPECIAL ORDER: CONTACT YOUR BISHOPS REPRESENTATIVE FOR MORE INFORMATION & TO ORDER THESE PRODUCTS



LOCKOUT/TAGOUT

What is Lockout/Tagout?

Lockout/Tagout (LOTO) is an important safety procedure that minimises the risk of injury or death during the maintenance or repair of equipment and machinery. A LOTO system ensures the energy source of equipment or machinery is shut down and can not be re-engaged until the required maintenance or repair is complete.

Lockout refers to the process of switching off and locking, also called isolating, the energy source of equipment or machinery using safety padlocks in conjunction with lockout devices that are specific to the energy source type. Energy sources vary, but commonly include electricity, hydraulic pressure, steam, gas or compressed air. An isolated energy source will prevent a worker from inadvertently switching on machinery or equipment while somebody is working on it.

Tagout refers to the labelling of a lockout device in order to communicate the reason for its isolation to others. Tags should provide comprehensive information on why isolation is required, the time of isolation and the name of the person who is performing the isolation. For a LOTO system to be effective, only the person who attaches a safety padlock and lockout device should remove them.

Who needs to use Lockout/Tagout?

Accidents that occur during maintenance or repair of equipment and machinery are often caused by non-isolated power sources and the dangers that come from this. All employers have a duty of care to workers on their site, and Lockout/Tagout procedures are therefore necessary for all workplaces with moving machinery or equipment.

What Lockout/Tagout equipment do I need?

To determine the LOTO equipment that you require at your workplace you should develop a comprehensive LOTO procedure. When putting together your LOTO procedure, you should consider:

- **How many employees you have on site** – this will affect the quantity of LOTO products required. For example, each employee needs to have their own safety padlock and they are the only person who is allowed to remove that padlock if it is isolating an energy source. Some employees may require more than one safety padlock, but their padlocks should all open with the same key to eliminate the need for carrying more than one key.
- **What energy sources you will need to isolate** – a comprehensive assessment of the machinery and equipment that may need to be isolated will allow you to determine the different LOTO products that are required. For example, some equipment may not have the ability to be isolated using just a safety padlock; they may require a valve lockout or a circuit breaker. You may also have machinery that will be worked on by more than one person at a time, which would require a safety lockout hasp or a group key box.

All machinery and equipment with hazardous energy sources should have their own tailored policy displayed next to the device.

All employees should be fully trained in following your Lockout/Tagout procedure.



0406 ZENEX™ NYLON SHACKLE PADLOCKS



- All components are non-sparking and non-magnetic – plastic, copper, brass
- Ideal for electrical isolations and areas prone to corrosion
- Tough, lightweight, non-conductive Zenex™ body withstands chemicals and performs effectively in extreme conditions
- Choice of 8 colours for easy lockout identification
- Key-retaining ensures padlocks are not left unlocked
- Laser engrave on up to 4 sides
- Reserved for safety keyway
- Keyed-to-differ as standard, also available keyed-alike and master-keyed
- Custom labelling available
- Shackle diameter: 6mm
- Shackle opening height: 38mm



Item Code	Colour	Bishops Code	Item Code	Colour	Bishops Code
0406BLK	Black	55075184	0406PRP	Purple	55075198
0406BLU	Blue	55075156	0406RED	Red	55075151
0406GRN	Green	55075161	0406YLW	Yellow	55075166
0406ORJ	Orange	55075178	-	-	-

0410 ZENEX™ LOCKOUT PADLOCKS



- Dedicated safety padlocks designed exclusively for lockout/tagout applications
- Tough, lightweight, dielectric Zenex™ body withstands chemicals and performs effectively in extreme conditions
- Choice of 8 colours for easy lockout identification
- Key-retaining ensures padlocks are not left unlocked
- Laser engrave on up to 4 sides
- Reserved for safety keyway
- Keyed-to-differ as standard, also available keyed-alike and master-keyed
- Custom labelling available
- Shackle diameter: 6mm
- Shackle opening height: 38mm



Item Code	Colour	Bishops Code	Item Code	Colour	Bishops Code
0410BLK	Black	55075170	0410PRP	Purple	55075187
0410BLU	Blue	55075155	0410RED	Red	55075150
0410GRN	Green	55075160	0410YLW	Yellow	55075165
0410ORJ	Orange	55075186	-	-	-

LOCKOUT PADLOCKS – KEYED ALIKE

- Safety padlocks suitable for lockout applications
- Nylon body with steel shackle
- High visibility colour
- Keyed alike
- Option to add additional padlocks on the same keying system
- 3 per pack
- Body size: 38 x 44 x 20mm
- Shackle diameter: 6.4mm



Item Code	Bishops Code
853206	55075175

S31 COMPACT LOCKOUT PADLOCKS



- Tough, lightweight, dielectric Zenex™ body withstands chemicals and performs effectively in extreme conditions
- 4.76mm 316 stainless steel shackle is ideal for fitting narrow or hard to reach isolation points
- Ideal for isolations outdoors or in corrosive environments
- Reserved for safety keyway
- Key-retaining ensures padlocks are not left unlocked
- Laser engrave on up to 4 sides
- Keyed-to-differ as standard, also available keyed-alike and master-keyed
- Custom labelling available
- Shackle diameter: 4.76mm
- Shackle opening height: 38mm



Item Code	Colour	Bishops Code	Item Code	Colour	Bishops Code
S31RED	Red	55075152	S31GRN	Green	55075162
S31YLW	Yellow	55075206	S31ORJ	Orange	55075212
S31BLU	Blue	55075208	S31WHT	White	55075176

A1105 ANODISED ALUMINIUM LOCKOUT PADLOCKS



- The American Lock No. A1105
- 38mm wide anodised aluminium body
- Chrome plated, boron alloy shackle for superior cut resistance
- Anodised finish is suitable for lockout in food processing facilities
- Corrosion resistant finish ideal for tough environments
- Shackle height: 25mm
- Shackle diameter: 6mm
- Keyed-to-differ as standard, also available keyed-alike and master keyed
- Longer shackles available on request



Item Code	Colour	Item Code	Colour	Item Code	Colour
S1105RED	Red	S1105GRN	Green	S1105BLK	Black
S1105YLW	Yellow	S1105PRP	Purple	S1105BRN	Brown
S1105BLU	Blue	S1105ORJ	Orange	S1105CLR	Silver

SPECIAL ORDER: PLEASE QUOTE ITEM CODE UPON ORDERING THIS PRODUCT

PHOTO IDENTIFICATION PADLOCK LABEL



- Padlock identification is an essential element of a safe and efficient lockout/tagout system
- Makes the user immediately identifiable
- Picture is sealed under laminate
- Accepts 19 x 19mm photo
- Suits Master Lock 406, 410, S31, and S33 padlocks
- Padlock not included
- 6 labels per pack



Item Code	Bishops Code
S142	55075145

ELECTRICIAN'S MINI LOCKOUT KIT

Includes:

- 1 x Carry Pouch
- 1 x Red Padlock
- 5 x Heavy Duty Lockout Tags
- 1 x Small 'No Hole' Breaker Lockout
- 1 x Large 'No Hole' Breaker Lockout
- 1 x Universal Multi-Pole Lockout
- 1 x Small Plug Lockout
- 1 x 25mm Lockout Jaws
- 1 x Single Breaker Lockout



Item Code	Bishops Code
848825	55075002

SAFETY LOCKOUT POUCHES & KITS



- Lockout kits combine and organise commonly used electrical and valve lockout devices
- Personal lockout kits are for an individual and all padlocks are supplied keyed alike
- Group lockout kits are for multiple workers and all padlocks are supplied keyed different
- More kits available, including valve lockout kits, combinations of electrical and valve lockout kits, or build your own



Item Code	Description	Bishops Code
1456P410KA	Personal Lockout Kit	55075013
1457V410KA	Personal Lockout Kit — Valve Focus	*1457V410KA
1457E410KA	Personal Lockout Kit — Electrical Focus	*1457E410KA
1457VE410KA	Personal Lockout Kit — Electrical & Valve Focus	*1457VE410KA
1458VE410	Group Lockout Kit — Electrical & Valve Focus	*1458VE410
S1010	Compact Lockout Pouch — Unfilled	55075001
S1017	Personal Lockout PVC Toolbox — Unfilled — 43.1(w)cm	*S1017
SAFETYPOUCH	Padlock Pouch — Unfilled	*SAFETYPOUCH
PEKS31REDKA6	Personal Lockout Pouch Kit	*PEKS31REDKA6

*** — SPECIAL ORDER: PLEASE QUOTE ITEM CODE UPON ORDERING THIS PRODUCT**

LOCKOUT HASPS



- Keeps equipment inoperative while repairs or maintenance are being undertaken
- Designed for multiple worker lockout



Item Code	Description	Size	Lock Capacity	Bishops Code
0416	Aluminium Hasp 25mm	25mm	6	55075111
0417	Aluminium Hasp 38mm	38mm	6	55075112
0418	Heavy Duty Steel Hasp	25mm	4	55075106
0419	Heavy Duty Steel Hasp	38mm	8	55075113
0420	Steel Hasp	25mm	6	55075105
0421	Steel Hasp	38mm	6	55075110
S430	Shackle Hasp	4mm	2	55075101
0428	Nylon Hasp	25mm	6	55075107
0429	Dual Jaw Aluminium Hasp		8	55075114
S440B	Aluminium Hasp		12	*S440B
S450B	Aluminium Hasp		24	*S450B

*** — SPECIAL ORDER: PLEASE QUOTE ITEM CODE UPON ORDERING THIS PRODUCT**



LOCKOUT/TAGOUT STATIONS & BOXES

SAFETY EQUIPMENT & CONSUMABLES

LOCKOUT STATION

- 4.7mm thick bright acrylic board with acrylic lock rails
- Tag pockets are clear polycarbonate and suit 76.2mm wide tags
- Board size: 343 x 343mm
- Includes:**
 - 10 x Safety Padlocks
 - 2 x 25mm Metal Hasps
 - 2 x 38mm Metal Hasps
 - 12 x Heavy Duty Tags



Item Code	Bishops Code
51187	55075009

WALL MOUNTABLE LOCKOUT STATIONS

- Central location to access safety padlocks, tags, hasps and other essential devices
- Integrated one piece moulded construction
- Durable polycarbonate with translucent lockable cover
- Wall mountable
- Reinforced snap-on clips inside
- Designed for multiple workers with all locks supplied keyed different
- More kits available



S1850V410



1482B



1482BP410



S1850E410



1483B



1483BP410



S1800



1484B



1484BP410



S1900VE410

Item Code	Description	Bishops Code
1482B	4 Lock Covered Station Without Accessories	55075016
1482BP410	4 Lock Covered Station With Accessories	55075015
1483B	10 Lock Covered Station Without Accessories	55075018
1483BP410	10 Lock Covered Station With Accessories	55075017
1484B	20 Lock Covered Station Without Accessories	55075021
1484BP410	20 Lock Covered Station With Accessories	55075019
S1800	Deluxe Safety Tag Station	*S1800
S1850V410	Lockout Station (Valve Focus) With Accessories	*S1850V410
S1850E410	Lockout Station (Electrical Focus) With Accessories	*S1850E410
S1900VE410	Deluxe Wall Mounted Station (Electrical & Valve Focus) With Accessories	*S1900VE410

* - SPECIAL ORDER: PLEASE QUOTE ITEM CODE UPON ORDERING THIS PRODUCT

GROUP LOCK BOXES



- Secure each lockout point with a single padlock and place the keys in the lock box
- All authorised employees then attach their personal padlocks to the lock box
- Durable powder coated finish
- 0503RED and 0503YLW can be mounted or carried between jobs and accept 14 padlocks or hasps
- S601 and S602 constructed from 430-grade stainless steel for corrosion resistance



0503RED

0503YLW



0498A



S601



S602

Item Code	Description	Capacity	Bishops Code
0498A	Latch Tight™ Portable Group Lock Box	12 Lock	55075012
0503RED	Latch Tight™ Group Lock Box	14 Lock	55075025
0503YLW	Latch Tight™ Group Lock Box	14 Lock	55075026
S601	Portable Group Lock Box with Key & Side Window	19 Lock	*S601
S602	Large Portable Group Lock Box with Key Window & Rewritable Tag	19 Lock	*S602

* - SPECIAL ORDER: PLEASE QUOTE ITEM CODE UPON ORDERING THIS PRODUCT

COMPLETE PERMIT CONTROL LOCKOUT STATION



- Various lockout solutions for permit control and group isolation
- Permit Control Station:**
 - Portable or wall mounted single location to display and protect paperwork and padlocks for group lockout
 - Modular design allows various options for placement and use
 - 430 grade stainless steel with impact resistant polycarbonate windows
 - Group lock box contains a multiple lock hand caddy, removable key cup, exterior lock holes for personal safety locks, plus a hole in the latch for the control lock
 - Rubber seal to protect documents from water damage



PH1



IB3



S3500



S3650



S3502



S3501

Item Code	Description	Bishops Code
PH1	PVC A4 Permit Document Holder	55075003
IB3	PVC Group Isolation Box - 14 Lock	*IB3
PERMIT CONTROL LOCKOUT STATION		
S3500	Permit Control Lockout Station	*S3500
S3501	Permit Control Lockout Station	*S3501
S3502	Wall Mounted Group Lock Box	*S3502
S3650	Group Lock Box & Wall Mount Bracket	*S3650

* - SPECIAL ORDER: PLEASE QUOTE ITEM CODE UPON ORDERING THIS PRODUCT

PRESSURISED GAS VALVE LOCKOUT



- Surrounds the gas valve handle to protect against accidental valve opening
- Works on valves with or without guarding
- Fits valves up to 76mm diameter
- Works with any Master Lock or American Lock safety padlock or lockout hasp
- Multiple workers can apply their personal safety padlocks
- Padlock not included



Item Code

S3910

SPECIAL ORDER: PLEASE QUOTE ITEM CODE UPON ORDERING THIS PRODUCT

ZENEX™ GATE VALVE LOCKOUTS



- Surrounds the valve operating handle to protect against accidental valve opening
- Designed for multiple worker lockout
- Tough, lightweight, dielectric Zenex™ construction
- 5 piece set includes 0480-0484



55075055

Item Code	Handle Diameter Capacity	Bishops Code
0480	25–76mm	55075050
0481	50–127mm	55075051
0483	152–254mm	55075053
0484	203–330mm	55075054
0485	Set 5 Piece – 0480, 0481, 0482, 0483 & 0484	55075055

CABLE LOCKOUT DEVICES



- Integrated safety hasp and cable is ideal for multiple circuit breaker panel and side-by-side gate valve lockouts
- Tough lightweight thermoplastic body withstands chemicals and performs effectively in extreme conditions
- Tough, flexible insulated cables

Retractable Cable Lockouts:

- Internal ratcheting system to increase tension
- Colour coded labels and cable for easy identification



Item Code	Description	Cable Length	Bishops Code
S806CBL3	Adjustable Cable Lockout – Steel Cable	0.9m	55075071
S806	Adjustable Cable Lockout – Steel Cable	1.8m	55075072
S806CBL15	Adjustable Cable Lockout – Steel Cable	4.5m	55075073
S856	Retractable Cable Lockout – Steel Core Cable	2.7m	*S856
S866	Retractable Cable Lockout – Nylon Core Cable	2.7m	*S866

*** – SPECIAL ORDER: PLEASE QUOTE ITEM CODE UPON ORDERING THIS PRODUCT**

BUTTERFLY VALVE LOCKOUT DEVICES



- Lightweight and compact design
- Attaches to handle to prevent activation during maintenance or repair
- Universal design fits a wide range of butterfly valves
- Quick and easy installation and removal



Item Code	Description	Bishops Code
S3920	Butterfly Valve Lockout without Cable	55075035
S3921	Butterfly Valve Lockout with 4.5(d) x 900(l)mm Cable	55075036

BALL VALVE LOCKOUTS



- Effective lockout of ball valves to prevent re-energisation during maintenance or repair
- Simple, tool-free installation
- Durable design and materials



Item Code	Description	Bishops Code
S3068	Seal Tight™ Ball Valve Lockout	55075062
S3080	Adjustable Ball Valve Lockout	55075063
S3476	Handle-On Lockout Fits 6–25mm	55075065
S3477	Handle-On Lockout Fits 32–76mm	55075066
0468L	Handle-Off Seal Tight™ Ball Valve Lockout	55075064

GET MORE AT BISHOPS



EXTENSION LEADS

Page 368

MINIATURE CIRCUIT BREAKER LOCKOUTS



- Effectively lockout virtually any electrical circuit breaker to prevent accidental re-energisation during maintenance or repair
- Durable design and materials
- Accepts Master Lock safety padlocks and lockout hasps



Item Code	Description	Bishops Code
0491B	Grip Tight™ Circuit Breaker Lockout Tall & Wide Toggles	55075023
0493B	Grip Tight™ Circuit Breaker Lockout Single & Double Toggles	55075022
S3821	Grip Tight™ Plus Miniature Circuit Breaker Lockout	*S3821
S3822	Grip Tight™ Plus Circuit Breaker Lockout	*S3822
S3823	Grip Tight™ Plus Oversized Circuit Breaker Lockout	*S3823
CBL-2	Small Circuit Breaker Lockout	*CBL-2
S2390	Miniature Circuit Breaker Lockout Pin-Out Toggles – <11mm	55075020
S2391	Miniature Circuit Breaker Lockout Pin-Out Toggles – >11mm	55075029
S2393	Miniature Circuit Breaker Lockout Universal Fit	55075031
S2394	Miniature Circuit Breaker Lockout Universal Fit – Tool Free	55075032
FL1	Fuse Blocker Lockout	*FL1

*** – SPECIAL ORDER: PLEASE QUOTE ITEM CODE UPON ORDERING THIS PRODUCT**



ELECTRICAL LOCKOUT/TAGOUTS, SDS STORAGE & SAFETY TAGS

ZENEX™ ELECTRICAL PLUG LOCKOUTS

- Surrounds the electrical plug to prevent accidental activation
- Easy to use rotating design works well in confined or restricted spaces
- Dielectric Zenex™ thermoplastic body
- Rewritable safety labels



Item Code	Description	Bishops Code
0487	120V & 240V	55075130
0488	240V & 250V	55075135

PLUG & HOIST CONTROL COVER

- Flexible and durable rip-stop nylon bag fits easily in safety tool boxes
- Lockout with up to 6 padlocks or hasps
- Versatile solution for effective lockout of electrical plugs, pneumatic controls and more



Item Code	Size	Dimensions	Bishops Code
0453L	Large	431(h) x 158(w)mm	55075076
0453XL	X-Large	660(h) x 254(w)mm	55075077

DOCUMENT STORAGE BOXES

- Convenient solution to safely storing and managing manuals and documents
- Provides a secure and weather-resistant place for any documents or paperwork
- Colour: Red



Item Code	Description	Size
23303	Large Front Opening	400(h) x 340(w) x 90(d)mm
23304	Medium Front Opening	368(h) x 279(w) x 54(d)mm
23306	Medium Top Opening	318(h) x 260(w) x 57(d)mm
23305	Tube Twist Lid	317(h) x 94(dia)mm

SPECIAL ORDER: PLEASE QUOTE ITEM CODE UPON ORDERING THIS PRODUCT

OUT OF SERVICE TAGS

- All tags come standard with string and an 8mm eyelet (suitable for a padlock to be attached)
- Printed on high quality 140gsm Polyart paper
- Easy to write on
- Weatherproof
- Tags sold individually
- 75 x 130mm



Item Code	Bishops Code
1423037	55075364

CAUTION LOCKOUT TAGS

- Durable polypropylene construction
- Suitable for lockout applications
- Size: 100(w) x 150(h)mm
- Yellow/black



Item Code	Bishops Code
842390	55075094

SAFETY & INFORMATION TAGS



- Durable polyester laminate resists water, grease and extreme temperatures
- Customise with name, department and expected completion time
- S4801:
 - Clear adhesive overlay allows tags to be personalised with photo
 - Industrial grade polypropylene
 - Survives frequent washdowns and humidity
- Caution & Information Tags:
 - Single use disposable tags
 - 200gsm waterproof non-tear material



S297

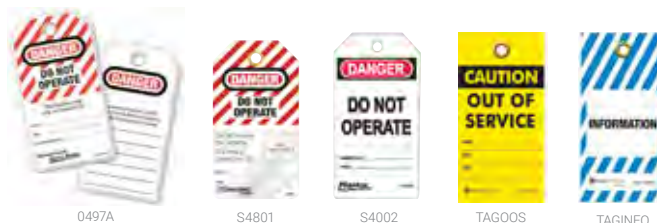

Item Code	Description	Size	Qty	Bishops Code
0497A	Danger – Do Not Operate Laminated Tag	79 x 146mm	12	55075096
S4801	Danger – Do Not Operate Self-Laminating Photo ID Tag	81 x 147mm	12	55075079
S297	Danger – Do Not Operate Flag	140 x 32mm	100	*S297
S4002	Guardian Extreme™ Danger – Do Not Operate Tag	76 x 146mm	6	55075082
TAGOOS	Caution Out of Service Tag – Yellow/Black	75 x 150mm	25	*TAGOOS
TAGINFO	Information Tag – Blue/White	75 x 150mm	25	*TAGINFO

* – SPECIAL ORDER: PLEASE QUOTE ITEM CODE UPON ORDERING THIS PRODUCT

SAFETY EQUIPMENT & CONSUMABLES

SAFETY TAG CARD STOCK

- 150 x 100mm
- Pack of 100



Item Code	Description	Bishops Code
B842357	Danger Out of Service	55075305
B842358	Danger Do Not Start	55075306
B842359	Danger Do Not Operate	55075307

SELF-LOCKING LOCKOUT TAGS

- Durable polypropylene material
- Self-locking design requires no additional string or ties
- Suitable for lockout applications
- Size: 85(w) x 160(h)mm
- 25 per pack



Item Code	Description	Bishops Code
847204	Warning Do Not Operate	55075359
847205	Danger Symbol	55075360
842552	Danger Out Of Service	55075361
842555	Danger Do Not Operate	55075362

DANGER LOCKOUT TAGS

- Durable polyester construction
- Double sided
- Features unauthorised removal statement
- Size: 76(w) x 140(h)mm



Item Code	Description	Bishops Code
66050	Danger Do Not Operate	55075355
65520	Danger Do Not Operate – Striped	55075356
65526	Danger Locked Out Do Not Operate	55075357

TWO PART LOCKOUT TAG

- 80 x 158mm



Item Code	Description	Pack Qty	Bishops Code
B59390	"Danger Do Not Operate"	100	55075375
B59391	"Danger Equipment Tagged Out"	25	55075377

SCAFFTAG KIT STANDARD MK1

- Tagging system that helps prevent working at height hazards and manage inspection procedures
- Weatherproof, UV protected and durable to withstand industrial environments
- Different colours indicate different loading classifications



- Includes:
- 10 x holders
 - 20 x inserts
 - 1 x marker pen

Item Code	Description	Bishops Code
B857184	ScaffTag Kit	55075475
B857167	Scaff Tag Holder– Includes 10 Tag Holders Only	55075480
B857210	ScaffTag Insert – Green (Pack of 50)	55075485
B857191	ScaffTag Insert – Red (Pack of 50)	55075490

APPLIANCE TEST TAGS

- 120 x 135mm



Item Code	Colour	Bishops Code
BAT103AP	Red	55075450
BAT104AP	Blue	55075455
BAT101AP	Yellow	55075460
BAT102AP	Green	55075465

RFID M-PRINCE HIGH FREQUENCY TAG

- Operates effectively with a very good read range, especially when attached to metal
- Rugged construction for high durability
- Can be attached by screws with the help of two holes
- Can also be provided with adhesive tape for easy attachment
- Flexible read/write range (reader dependent)
- 90(l) x 34(w) x 7(h)mm
- Colour: Yellow
- Other colours available on request



Item Code
RFID1

SPECIAL ORDER: PLEASE QUOTE ITEM CODE UPON ORDERING THIS PRODUCT

RFID M-WARRIOR HIGH FREQUENCY TAG

- Operates effectively with good read range when attached to metal
- Rugged construction IP68 for high durability
- Can be attached by thread or cable tie
- Can also be provided with adhesive tape for easy attachment
- 62(l) x 14(w) x 13(h)mm
- Colour: Yellow
- Other colours available on request



Item Code
RFID4

SPECIAL ORDER: PLEASE QUOTE ITEM CODE UPON ORDERING THIS PRODUCT



DANGER SIGNS

Item Code	Description	Size	Material	Bishops Code
SSD-HVCP	Danger High Voltage	225 x 300mm	Poly	55070282
SSD-HVAM	Danger High Voltage	600 x 450mm	Metal	55070397
SSD-NEAPOAM	Danger No Entry Authorised Personnel Only	600 x 450mm	Metal	55070390
SSD-NEAPOCM	Danger No Entry Authorised Personnel Only	225 x 300mm	Metal	55070905
SSD-DNEAM	Danger Do Not Enter	600 x 450mm	Metal	55070852
SSD-KOAM	Danger Keep Out	600 x 450mm	Metal	55070858
SSD-CSDNEAM	Danger Construction Site	600 x 450mm	Metal	55070395
SSD-FLAM	Danger Flammable Liquids	600 x 450mm	Metal	55070396
SSD-FKFHABM	Danger Flammable Keep Flames & Heat Away	450 x 300mm	Metal	55070854
SSD-FEKCBM	Danger Fire Exit Keep Clear	300 x 450mm	Metal	55070400
SSD-WAAM	Danger Workers Above	600 x 450mm	Metal	55070860
SSD-OPAM	Danger Open Pit	600 x 450mm	Metal	55070862
SSW-GDDAM	Danger Guard Dogs On Duty	600 x 450mm	Metal	55070866
SSD-LOFTAM	Danger Look Out For Truck	600 x 450mm	Metal	55070878
SSD-DFAM	Danger Diesel Fuel	600 x 450mm	Metal	55070880
SSD-CSAM	Danger Confined Space Entry By Permit	600 x 450mm	Metal	55070897
SSD-CSAF	Danger Confined Space Entry By Permit	600 x 450mm	Fluted	55070898
CS-CTBP	Danger Worker In Confined Space	450 x 300mm	Fluted	55070901
SSW-BVAM	Beware of Vehicles	600 x 450mm	Metal	55070882

TRAFFIC MANAGEMENT SIGNS

RMQ-TC1220AC1	Reduce Speed	1,200 x 300mm	Metal	55070055
SSFM-KLDAAM	Keep Left	600 x 450mm	Metal	55070045
CS-CAUTPC*M	Caution Pedestrian Crossing	1,200 x 600mm	Metal	55070050
CS-CTJM	Traffic Hazard Ahead - Slow Down	900 x 600mm	Metal	55070060
CS-CT*AC1	School Children Crossing	600 x 450mm	Reflective Metal	55070065
CS-CT*AC1	Speed Hump Ahead	450 x 600mm	Metal	55070070
SSFM-NPAM	No Parking Anytime	450 x 600mm	Metal	55070115
RS-R12A-AC1	Give Way	750mm Triangle	Metal	55070245
RS-R11A-AC1	Stop	600 x 600mm	Reflective Metal	55070250
CS-CT*M	Stop	460 x 460mm	Metal	55070255
SSFM-NP1AM	No Parking	600 x 450mm	Metal	55070265
SSM-BISHAM	Blind Intersection Sound Horn	600 x 450mm	Metal	55070105
SSFM-NPBM	No Parking Anytime	300 x 450mm	Metal	55070889
SSFM-NPDBM	No Parking in Driveway	300 x 450mm	Metal	55070890
SSFM-PLZBM	Loading Zone	300 x 450mm	Metal	55070891
SSFM-NPBUSBM	No Parking Bus Stop	300 x 450mm	Metal	55070892
SSFM-NVBM	No Vehicles Beyond This Point	300 x 450mm	Metal	55070893
SSFM-AVOBM	Authorised Vehicles Only	300 x 450mm	Metal	55070894
SSFM-RPOBM	Reverse Parking Only	300 x 450mm	Metal	55070895
SSFM-NP1BM	No Parking	300 x 450mm	Metal	55070896
SSRA-HVKOBP	Restricted Area High Voltage Keep Out	450 x 300mm	Poly	55070300
SSFM-PTAZBM	No Parking Tow Away Zone	300 x 450mm	Metal	55070302
SSW-KCAM	Keep Clear	600 x 450mm	Metal	55070884
CS-ENYOAM	Entry Only	450 x 600mm	Metal	55070080
CS-CTCM	Exit Only	300 x 225mm	Metal	55070085
CS-CTCP	Exit	300 x 225mm	Poly	55070292
SSP-NEAM	No Entry	300 x 600mm	Metal	55070310

SPEED SIGNS

SSFM-S5AMC1	5kph	600 x 450mm	Reflective Metal	55070015
RS-R41A10-AC1	10kph	600 x 450mm	Reflective Metal	55070020
RS-R41A20-AC1	20kph	600 x 450mm	Reflective Metal	55070025
SSFM-S15AMC1	15kph	600 x 450mm	Reflective Metal	55070030
RS-R41B40-AC1	40kph	900 x 600mm	Reflective Metal	55070035

PERSONAL PROTECTION & FIRST AID SIGNS

SSRA-APOAM	Restricted Area Authorised Personnel Only	600 x 450mm	Metal	55070872
SSM-EPAAM	Eye Protection Must Be Worn	600 x 450mm	Metal	55070210
SSM-FPAAM	Foot Protection Must Be Worn	600 x 450mm	Metal	55070220
SSM-HEDPAAM	Head Protection	600 x 450mm	Metal	55070230
SSM-HPAAM	Hearing Protection	600 x 450mm	Metal	55070240
SSM-RAAM	Respirator	600 x 450mm	Metal	55070330
SSM-DMAAM	Dust Mask	600 x 450mm	Metal	55070335
SSM-HDPAAM	Hand Protection	600 x 450mm	Metal	55070340
SSM-SGAAM	Safety Goggles	600 x 450mm	Metal	55070350
SSM-FSAAM	Face Shield Must Be Worn	600 x 450mm	Metal	55070360
SSM-HVCAM	Hi-Vis Clothing or Vest Must Be Worn	600 x 450mm	Metal	55070368
SSM-PCMBWAM	Protective Clothing Must Be Worn	600 x 450mm	Metal	55070370
SSM-SHAM	Safety Harness	600 x 450mm	Metal	55070372
SSM-PEAC_t2_10_5_14J	Multi-Conditions Protective Equipment	900 x 600mm	Metal	55070375
SSE-EEWAM	Emergency Eyewash	600 x 450mm	Metal	55070378
SSE-FAAM	First Aid	600 x 450mm	Metal	55070379
SSF-FECPABE200S	AB(E) Type Dry Chemical First Extinguisher	200mm Dia.	Self-Adhesive Vinyl Sticker	55070380
SSE-FASBP	First Aid Station	450 x 300mm	Poly	55070308

ADVISORY SIGNS

SSFM-RLDS	Ladies	180 x 250mm	Self-Adhesive Vinyl Sticker	55070296
SSFM-RGDS	Gentlemen	180 x 250mm	Self-Adhesive Vinyl Sticker	55070298
SSE-SRB1200M	Safety Record	1,200 x 600mm	Metal	55070886
SSFM-SOFFAM	Site Office	600 x 450mm	Metal	55070874
SSNVROBM	All Visitors Register At Office	300 x 450mm	Metal	55070867
SSN-VROAM	All Visitors Register At Office	600 x 450mm	Metal	55070868
SSM-SOWNIUBP	Switch Off When Not In Use	450 x 300mm	Poly	55070315
SSD-CWOAM	Crane Working Overhead	600 x 450mm	Metal	55070850

EMERGENCY SIGNS

SSE-EAPAM	Emergency Assembly	600 x 450mm	Metal	55070876
SSE-MPAM	Muster Point	600 x 450mm	Metal	55070877

SMOKING, BUAI & ALCOHOL SIGNS

SSD-NSAM	Danger No Smoking	300 x 450mm	Metal	55070393
SSP-NSCM	No Smoking	300 x 225mm	Metal	55070318
SSP-NSAM	No Smoking	600 x 400mm	Metal	55070320
SSFM-SAAM	Smoking Area	650 x 400mm	Metal	55070325
SSP-NSFAM	No Smoking - Flammable	600 x 450mm	Metal	55070392
SSP-NSBPAM	No Smoking Beyond This Point	600 x 450mm	Metal	55070394
SSP-NSDS	No Smoking	250 x 180mm	Self-Adhesive Vinyl Sticker	55070820
SSD-FSNSAM	Fuel Storage No Smoking	600 x 450mm	Metal	55070856
CS-CT_S	No Chewing Buai	450 x 450mm	Self-Adhesive Vinyl Sticker	55070830
SSP-ANPSAM	No Alcohol Permitted On Site	600 x 450mm	Metal	55070870

WELDING SIGNS

SSW-BWFCM	Beware Of Welding Flash	300 x 225mm	Metal	55070386
SSW-BWFAM	Beware Of Welding Flash	600 x 450mm	Metal	55070387
SSW-DNWWAM	Do Not Watch Welding Arc	600 x 450mm	Metal	55070388

SPEED LIMIT SIGNS

- Class 1 reflective aluminium
- Various sizes



55070040

Description	Size	Bishops Code
5kph	600 x 450mm	55070015
10kph	600 x 450mm	55070020
15kph	600 x 450mm	55070030
20kph	600 x 450mm	55070025
40kph	900 x 600mm	55070035
50kph	600 x 600mm	55070040

“NO RIGHT TURN” SIGN

- Class 1 reflective aluminium
- 600 x 600mm



Size	Bishops Code
600 x 600mm	55070110

STOP/SLOW LOLLIPOP SAFETY SIGN

- Suitable for traffic control in construction sites, school zones and pedestrian crossings
- Double-sided
- Letter height: 150mm
- Diameter: 457mm



Item Code	Bishops Code
TTCSSAL 450AL	55070275

“SLOW” ROAD CONE SIGN

- Rectangular shape with silk-screen printing
- Easy to fasten on top of a traffic cone
- Can quickly barricade dangerous sites and direct traffic safely
- 220(l) x 270(w)mm
- Colour: Orange
- Road cones not included



Item Code	Bishops Code
844289	55060550

WET FLOOR DELUXE FLOOR STAND



- Height: 670mm
- Yellow



Bishops Code
55070304

GET MORE AT BISHOPS ▶

MOPS
Page 406

REFLECTIVE SAFETY TRIANGLE

- ECE regulation No. 27/E11
- Durable and impact resistant
- Hi-vis reflection for extra safety
- Easy to erect and set up
- Orange
- Triangle dimensions: 50(w) x 450(h)mm



Size	Bishops Code
50 x 450mm	55060590

REFLECTIVE ROAD TRAFFIC CONES

- Flexible and durable PVC cone
- Square base prevents cone rolling away even when knocked over
- Reflective collar increases visibility
- Helps with marking hazardous areas to prevent accidents
- Orange



Height	Bishops Code
460mm	55060220
700mm	55060240
900mm	55060242



TRAFFIC & SITE CONTROL

SAFETY EQUIPMENT & CONSUMABLES

RETRACTABLE ROAD CONE BAR



- For temporary barricading
- Adjustable from 115cm to 2m
- Expandable/retractable
- Suits most road cones
- Striped for visual intensity
- Ideal for controlling crowds, warning of road hazards and directing traffic
- Black/yellow
- Road cones not included



Item Code	Bishops Code
7106	55060500

REFLECTIVE TRAFFIC CONTROL BOLLARD

- Low-density polyethylene post with octagonal recycled soled rubber base
- Tough, sturdy and stable
- Ideal for controlling crowds and directing traffic around dangerous areas
- 24cm reflective collar
- Two-piece design is simple and convenient
- Orange
- Base weight: 6kg
- Base diameter: 420mm
- Post diameter: 80mm
- Height: 1,150mm



Item Code	Bishops Code
7272	55060260

BARRIER MESH

- Tough, durable polyethylene
- Lightweight and reusable
- Ideal for temporary construction sites, road working and recreation areas
- Provides excellent visibility for hazardous areas
- Orange
- Roll size: 1 x 50m
- Weight: 8kg per roll

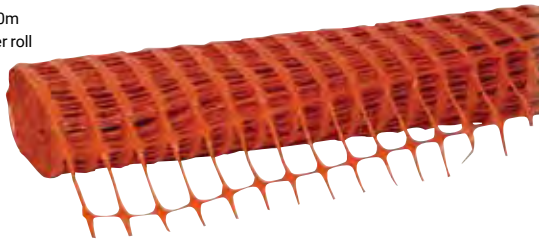

Item Code	Bishops Code
6400	55060140

FLURO ORANGE FLAG BUNTING



- Hi-vis fluoro orange
- Flag height: 200mm
- Length: 25m



Item Code	Bishops Code
7120	55060100

PVC BUNTING FLAGS



- Use to cordon off an area to prevent unauthorised access
- Provides excellent warning for hazard areas
- Hi-vis fluoro orange PVC flags
- High strength nylon rope
- Length: 30m



Item Code
BUNTINGO-30M
SPECIAL ORDER: PLEASE QUOTE ITEM CODE UPON ORDERING THIS PRODUCT

REFLECTIVE PVC BUNTING FLAGS



- Use to cordon off an area to prevent unauthorised access
- Provides excellent warning for hazard areas
- Hi-vis fluoro orange PVC flags
- Reflective tabs inbetween flags
- High strength nylon rope
- Length: 30m



Item Code	Bishops Code
BUNTINGDN-30M	55060115

DANGER SAFETY BARRICADE TAPE



- Heavy duty plastic
- High visibility colours and wording
- Suitable for marking out hazardous areas
- Red and white stripes with black text
- 75mm width



Length	Bishops Code
100m	55060060
300m	55060052

HAZARD BARRIER TAPE

- High visibility, lightweight and non-adhesive
- Suitable for marking traffic hazards and other dangerous areas
- Reusable
- 75mm width



Colour	Length	Bishops Code
Red & White	100m	55060020
Red & White	300m	55060022
Black & Yellow	100m	55060040
Black & Yellow	300m	55060045

CAUTION SAFETY BARRICADE TAPE

- High visibility, lightweight and non-adhesive
- Suitable for marking traffic hazards and other dangerous areas
- Reusable
- Yellow with black text
- 75mm width



Length	Bishops Code
100m	55060049
250m	55060050

EL SERIES SAFETY BARRIER REELS

- For creating temporary barriers and identifying dangerous areas
- Robust plastic outer reel casing
- Wall mountable with swivel steel wall bracket
- Compact design allows mounting in most situations
- Automatic spring rewind
- Tape length: 16m



Item Code	Description	Tape Colour
BR50010D	Danger Barrier Reel	Red/White
BR50020C	Caution Barrier Reel	Yellow/Black

SPECIAL ORDER: PLEASE QUOTE ITEM CODE UPON ORDERING THIS PRODUCT

ANTI-SLIP ADHESIVE SAFETY TRACK

- Premium high traction non-slip tape
- Easy to install with peel off adhesive backing
- Fuel, water and fluid resistant
- Silicon carbide grit for durable, consistent slip resistance
- Barefoot grade suits general purpose use
- Commercial grade for heavy duty use



Item Code	Size	Colour	Bishops Code
BAREFOOT GRADE			
3335-50	50mm x 18.3m	Yellow	55570101
3335-100	100mm x 18.3m	Yellow	55570102
3335-150	150mm x 18.3m	Yellow	55570103
3360-50	50mm x 18.3m	Yellow & Black Stripe	55570104
3100-25	25mm x 18.3m	Black	55570106
3100-50	50mm x 18.3m	Black	55570107
3100-75	75mm x 18.3m	Black	55570108
3100-100	100mm x 18.3m	Black	55570109
3100-150	150mm x 18.3m	Black	55570110

Item Code	Size	Colour	Bishops Code
COMMERCIAL GRADE			
3200-25	25mm x 18.3m	Black	*3200-25
3200-50	50mm x 18.3m	Black	*3200-50
3200-75	75mm x 18.3m	Black	*3200-75
3200-100	100mm x 18.3m	Black	*3200-100
3200-150	150mm x 18.3m	Black	*3200-150

* - SPECIAL ORDER: PLEASE QUOTE ITEM CODE UPON ORDERING THIS PRODUCT

SAFETY WALK™ GENERAL PURPOSE ANTI-SLIP TAPE



- A highly durable mineral coated slip resistant surface
- General purpose tread, designed for use in light to heavy shoe-traffic areas
- Ideal for entrances, walkways, loading docks, machinery, vehicles and more



Item Code	Size	Colour	Bishops Code
70071667045	25mm x 18.2m	Black	65230094
70070543528	50mm x 18.2m	Black	65230096
70070544351	100mm x 18.2m	Black	65230098
70070975647	100mm x 18.2m	Yellow	65230100
70070544369	150mm x 18.2m	Black	65230102

DIAMOND GRADE™ REFLECTIVE TAPE

- Highly reflective, fluorescent, wide angle performance delivers outstanding vehicle/object visibility, night and day
- Sealed edge prevents delamination
- Strong adhesive provides permanent bond to a variety of surfaces
- Exceeds AS1906.1 Class 1W standards (9963ES), meets AS1906.2 Class 1A standards (983)



Reflective Tape Applied to Trucks

Item Code	Series	Size	Colour	Bishops Code
XA010013309	DG39963ES	45.7m x 50.8mm	Fluoro Yellow	55595041
XA010017680	DG39963ES	45.7m x 76mm	Fluoro Yellow	55595042
XA010013911	DG39963ES	45.7m x 101.6mm	Fluoro Yellow	55595043
XA010012616	983	45.7m x 50.8mm	White	55595045
XA010013234	983	45.7m x 101.6mm	White	55595046
XA010012632	983	45.7m x 50.8mm	Red	55595047
XA010013176	983	45.7m x 101.6mm	Red	55595048
AR010596575	983	15m x 50mm	White	55595050
AR010596583	983	15m x 50mm	Yellow	55595051
AR010596591	983	15m x 50mm	Red	55595052
AR010602290	983	15m x 50mm	Fluoro Yellow	55595053
AR010602308	983	15m x 76mm	Fluoro Yellow	55595054



AERIAL WHIPS & SAFETY LIGHTING

SAFETY EQUIPMENT & CONSUMABLES

LED AERIAL BUGGY WHIP

- Vehicle whip flag with LED light
- Standard mesh flag
- Quick release mounting base
- Length: 2.4m



Item Code	Description	Bishops Code
BW1024	2.4m Buggy Whip	86485017
BWDG3	Replacement 12/24V LED Globe	86485019
BWSB700	Large Spring Base – Suits Whips Over 1.8m	86485018

AERIAL WHIP WITH FLAG

- Metal with PVC outer casing
- Hi-vis flag: 110 x 950mm
- 2.4m length

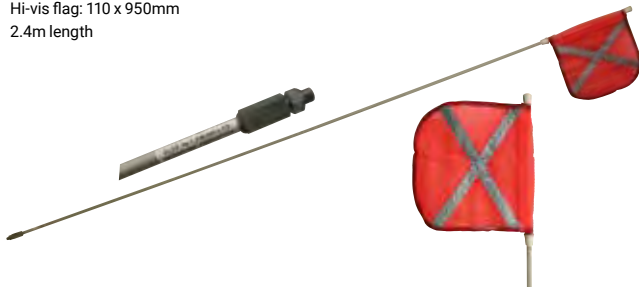

Item Code	Bishops Code
WAN-2.4M	86485015

GET MORE AT BISHOPS



HI-VIS CLOTHING & VESTS

From Page 66

HAZARD LIGHT STICKS

- Non-toxic and non-flammable
- Suitable to store in first aid and emergency kits
- Length: 150mm



Colour	Bishops Code	Colour	Bishops Code
Yellow	86480096	White	86480099
Orange	86480097	Green	86480100
Blue	86480098	–	–

AMBER HAZARD WARNING LAMP

- High impact resistance and durable plastic body with polycarbonate lens offer maximum light output
- Loop at top of lens for easy handling or fixing to scaffolding
- Automatic on and off
- Uses 2 x 6V, 509 batteries (not included)



Diameter	Bishops Code
112mm	30220190

AMBER REVOLVING WARNING LIGHTS

- Base diameter: 220mm
- Height: 257mm
- Flash rate: 130/min



Voltage	Bishops Code
DC 12V	30220160
DC 24V	30220180

AMBER ROTATING BEACON LIGHT

- High impact polycarbonate lens
- Magnetic base with cigarette lighter plug
- 3.5m spiral lead
- Current: 4.4amp @ 12V, 2.6A @ 24V
- Base diameter: 153mm
- Lens diameter: 110mm
- Height: 180mm
- Globe not included



Item Code	Bishops Code
35.205.000.01	30220005

AMBER ROTATING LED BEACON LIGHTS

- High intensity LED beacon lamp
- Fully sealed against dust and moisture
- Lightweight polycarbonate housing
- Flash patterns: 12 x strobe patterns, 2 x rotating patterns, steady on
- 50,000 Hour LED lifespan
- 9–32V
- IP67 Rated
- Size: 146 x 155mm
- SAE J845 Class I & CA13 Approved, ECE Reg R65 & R10



Item Code	Description	Bishops Code
281R-A	Beacon With 3-Bolt Mount	30220014
281RM-A	Beacon With Magnetic Mount	30220016

LED AMBER ROTATING BEACON

- 12-80V
- 3 bolt mount alloy base
- Dimensions: 130(dia) x 93(h)mm



Item Code	Bishops Code
LS9785	30220012

LED AMBER ROTATING BEACON

- 12-80V
- LED amber rotating beacon
- Magnetic base mount
- Comes with cigarette lighter plug
- Dimensions: 130(dia) x 93(h)mm



Item Code	Bishops Code
LS9787	30220010

HI-OPTICS LED ROTATING BEACON

- Combines precision, rotating optics with 8 high intensity LEDs
- SAE class 1 light output
- Features an ultra quiet, brushless magnetic drive system, low current draw, and die-cast aluminium flange base
- High impact polycarbonate amber lens
- Dual voltage 12/24V
- Current draw: 1.7A @ 12V
- Base diameter: 161mm
- Light diameter: 121mm
- Height: 157mm



Item Code	Bishops Code
35.201.000.01	30221020

AMBER REVOLVING WARNING STROBE LIGHT

- Magnetic base with plugs for attaching to vehicles
- Voltage: DC 12V/24V, AC 110V/220V
- Flash rate: 130/min
- Diameter: 122mm
- Height: 182mm



Item Code	Bishops Code
SE5120	30220120

4X4 LED MINEBAR

- Heavy duty automotive lighting unit
- Aluminum housing
- 12/24V
- 2 x LED Combination lamps
- Low profile amber LED beacon
- Brigade tonal sound reversing alarm
- Dimensions: 1,275(l) x 124(w) x 165(h)mm



Item Code	Bishops Code
HU9770	30250500

LED MINEBAR

- Heavy duty unit with multiple mounting options
- 12/24V
- 2 x LED Combo lamps
- Low profile amber LED beacon
- 2 x LED Work lamps
- 97dB alarm
- Dimensions: 1,275(l) x 125(w) x 165(h)mm



Dimensions	Bishops Code
HU9771	30250510

SIGNAL AIR HORN

- Suitable for marine, sports and safety applications
- Does not contain fluorocarbons
- Cannister included
- 380ml



Item Code	Bishops Code
3210004	30221110

HEAVY DUTY SIREN

- Suitable for emergency warnings, start/stop alarms, fire and evacuation situations
- Has an impact resistant metal case for extra durability
- Easy to install
- DC 12V/24V
- 75(dia) x 82(h)mm
- Colour: Red



Item Code	Bishops Code
SE5311	30222100





02

CLOTHING & FOOTWEAR

PANTS & COVERALLS

Cargo & Work Pants	63
Work Shorts	64
Coveralls	64

SHIRTS

Long Sleeve Shirts	66–67
Short Sleeve & Polo Shirts	67–68

JACKETS & WET WEATHER GEAR

Hi-Vis Jackets	69
Raincoats & Rain Pants	70–72
Poncho	72

SPECIALTY CLOTHING

Insect Repellent Long Sleeve Shirts	72–73
Insect Repellent Cargo Pants & Denim Jeans	74
Fire Retardant Shirts, Pants & Coveralls	75–77

BODY PROTECTION

Disposable & Chemical Coveralls	77–79
Hair & Shoe Covers, Aprons & Gaiters	79
Chainsaw Chaps & Kits	80
Back Support Belt	80

VESTS

Hi-Vis Safety Vests	80
---------------------------	----

FOOTWEAR

Gumboots	82–83
Elastic-Sided Safety Boots	84–85
Lace-Up Safety Boots	86–87
Zip-Up Safety Boots	87–88
Pull-On Safety Boots	89
Safety Shoes	89
Socks & Laces	89



CLOTHING



GSM Weight

GSM stands for grams per square metre and is the standard measurement for fabric weight. The lower the GSM value, the lighter the fabric; the higher the GSM number, the denser the fabric will be.

Reflective Tape

In day/night working environments it is a requirement that hi-vis clothing has reflective tape. Reflective tape provides extra visibility, primarily when working around moving vehicles.

Unique reflective taping styles can also help distinguish staff from visitors.

Speak to Bishops about custom tape configurations.

Ventilation

Clothing ventilation supports the removal of heat from the clothing microclimate which allows the wearer to stay cool in warm environments. Airflow from the ventilation can also have an antiperspirant effect which can slow or postpone the effects of heat stress.

Non-ventilated clothing does not have any air vents, providing better insulation from cold weather.

UPF Ratings

Safety clothing offers protection from the sun's harmful ultraviolet rays. The grading of this protection is commonly referred to as a garment's Ultraviolet Protection Factor (UPF). The UPF rating provides information on how much UV will pass through dry material that is not stretched. There are five UPF ratings for clothing: UPF15, 30, 40, 50 and 50+.

A UPF factor of 50 indicates the skin will have 50 times more protection from UV rays while covered than if it was in direct sunlight. The protection can also be explained as allowing 1/50th of the sun's UV rays to penetrate the skin, giving 98% protection from sunlight.

UPF50 is the recommended minimum protection for harsh Australian conditions.

AS/NZS 4399:1996 and AS/NZS 4399:2017 provide information on the capability of certain clothing materials to provide protection against ultraviolet radiation, including ultraviolet rays generated by the sun. Clothing that claims to provide UPF protection will need to conform to the requirements outlined in this standard.

Day vs Night Hi-Vis

The AS/NZS 4602.1: 2011 safety standard stipulates the minimum requirements for high visibility clothing in high risk applications. This includes people who work around moving vehicles, equipment or machinery. The two main classes of hi-vis garments are Class D and Class N, which specify requirements for daytime clothing and night time clothing respectively.



X Style

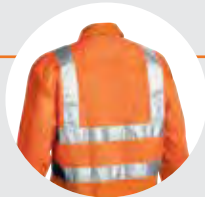

H Style



Hoop Pattern

Class D clothing is for daytime use only. These garments are designed to provide high visibility in daytime conditions but are generally ineffective in the dark. To meet the AS/NZS 4602.1:2011 standard, a Class D garment must use an approved hi-vis colour that encircles the torso and covers 0.4m² of the upper body.

Class N clothing is designed to provide high visibility in the dark when viewed under retroreflected light, such as vehicle headlights. Reflective tape is applied to Class N garments in one of three compliant patterns – H style, X style or a hoop pattern. There is no required background colour for a Class N garment.

Class D/N garments must meet the specifications for both Class D and Class N, and are designed to provide high visibility at any time of the day or night.

Clothing that adheres to AS/NZS 4602.1:2011 will also need to meet the requirements of AS/NZS 1906.4:2010, which specifies the photometric, colorimetric and physical property requirements for high-visibility materials used in safety clothing.

HEAVY DUTY DRILL PANTS

- Heavy duty 320gsm cotton drill
- Nickel zip fly
- Two jean-style side pockets
- One fob pocket (coin pocket)
- Two rear pockets
- Cargo-style pocket on outside of right leg



Size	NAVY	KHAKI	OLIVE
REGULAR	Bishops Code	Bishops Code	Bishops Code
26	55560426	—	55560326
28	55560428	55560528	55560328
30	55560430	55560530	55560330
32	55560432	55560532	55560332
34	55560434	55560534	55560334
36	55560436	55560536	55560336
38	55560438	55560538	55560338
40	55560440	55560540	55560340
42	55560442	55560542	55560342
44	55560444	55560544	55560343
46	55560445	55560546	—

WOMEN'S HEAVY DUTY DRILL PANTS

- Heavy duty 320gsm cotton drill
- Nickel zip fly
- Two jean-style side pockets
- One fob pocket (coin pocket)
- Two rear pockets
- Small cargo-style pocket on outside of right leg



Size	NAVY	KHAKI
REGULAR	Bishops Code	Bishops Code
6	55561426	—
8	55561428	—
10	55561430	55561530
12	55561432	55561532
14	55561434	55561534
16	55561436	55561536
18	55561438	55561538

REFLECTIVE HEAVY DUTY DRILL PANTS

- Heavy duty 320gsm cotton drill
- Nickel zip fly
- Two jean-style side pockets
- One fob pocket (coin pocket)
- Cargo-style pockets on outside of each leg
- Two rear pockets
- Hi-vis reflective 3M Scotchlite™ taping at the knees



Size	NAVY	KHAKI	OLIVE
REGULAR	Bishops Code	Bishops Code	Bishops Code
26	55560726	55560826	—
28	55560728	55560828	55560628
30	55560730	55560830	55560630
32	55560732	55560832	55560632
34	55560734	55560834	55560634
36	55560736	55560836	55560636
38	55560738	55560838	55560638
40	55560740	55560840	55560640
42	55560742	55560842	55560642
44	55560744	55560844	55560643
46	55560746	55560846	—

WOMEN'S REFLECTIVE HEAVY DUTY DRILL PANTS

- Heavy duty 320gsm cotton drill
- Nickel zip fly
- Two jean-style side pockets
- One fob pocket (coin pocket)
- Two rear pockets
- Cargo-style pocket on outside of right leg
- Hi-vis reflective 3M Scotchlite™ taping at the knees



Size	NAVY
REGULAR	Bishops Code
8	55561728
10	55561730
12	55561732
14	55561734
16	55561736
18	55561738



DRILL SHORTS & COVERALLS

CLOTHING & FOOTWEAR

HEAVY DUTY DRILL SHORTS

- 100% heavy duty cotton drill, 320gsm
- Two rear pockets with button closure
- One mobile phone pocket
- Zip front with metal button



Size	NAVY	KHAKI	OLIVE
	Bishops Code	Bishops Code	Bishops Code
28	–	55550328	55550228
30	55550130	55550330	55550230
32	55550132	55550332	55550232
34	55550134	55550334	55550234
36	55550136	55550336	55550236
38	55550138	55550338	55550238
40	55550140	55550340	55550240
42	55550142	55550342	55550242

HEAVY DUTY DRILL LONG SLEEVE COVERALLS

- 100% cotton, 200gsm
- Two chest pockets with zip closures
- Button up front
- Two rear pockets
- Two jean-style side pockets



Size	NAVY	ORANGE	KHAKI	OLIVE
	Bishops Code	Bishops Code	Bishops Code	Bishops Code
Small	55520109	55520209	55520309	55520409
Medium	55520110	55520210	55520310	55520410
Large	55520120	55520220	55520320	55520420
X-Large	55520130	55520230	55520330	55520430
2X-Large	55520140	55520240	55520340	55520440
3X-Large	55520150	55520250	55520350	55520450

REFLECTIVE HEAVY DUTY DRILL LONG SLEEVE COVERALLS

- 100% cotton, 200gsm
- Two chest pockets with zip closures
- Button up front
- Two rear pockets
- Two jean-style side pockets
- Hi-vis reflective 3M Scotchlite™ taping



Size	NAVY	ORANGE	KHAKI	OLIVE
	Bishops Code	Bishops Code	Bishops Code	Bishops Code
Small	55520505	55520605	55520705	55520805
Medium	55520510	55520610	55520710	55520810
Large	55520520	55520620	55520720	55520820
X-Large	55520530	55520630	55520730	55520830
2X-Large	55520540	55520640	55520740	55520840
3X-Large	55520550	55520650	55520750	55520850
4X-Large	55520560	55520660	–	–

REFLECTIVE HEAVY DUTY DRILL 2 TONE LONG SLEEVE COVERALLS

- 100% cotton, 200gsm
- Two chest pockets with zip closures
- Button up front
- Two rear pockets
- Two jean-style side pockets
- Hi-vis reflective 3M Scotchlite™ taping

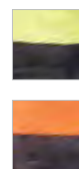

Size	YELLOW/NAVY	ORANGE/NAVY
	Bishops Code	Bishops Code
Small	55520959	55520909
Medium	55520960	55520910
Large	55520970	55520920
X-Large	55520980	55520930
2X-Large	55520990	55520940
3X-Large	55520995	55520950

MEN'S SIZE GUIDE

MEASUREMENTS

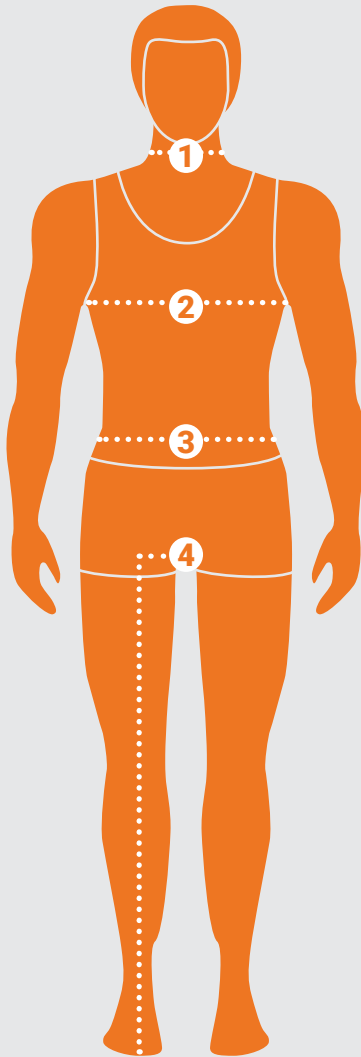

- 1 NECK:** Measure around the neck where the top of the shirt collar would sit.
- 2 CHEST:** Standing naturally, measure around the fullest part of the chest and shoulder, under the arms with your arms at resting position.
- 3 WAIST:** Measure over undergarments at the natural waistline (usually approx. 1cm below the navel).
- 4 IN-LEG:** Measure from crotch to floor, with shoes.

SHIRTS

Size	XS	S	M	L	XL	2XL	3XL	4XL	5XL	6XL
To fit neck size (cm)	36	37/38	39/40	41/42	43/44	46	48	50	52	54
To fit chest size (cm)	81	89	97	105	113	121	129	137	145	153
To fit chest size (inches)	32	35	38	41	44.5	47.5	50.5	54	57	60

PANTS

Size REGULAR	72R	77R	82R	87R	92R	97R	102R	107R	112R	117R	
Size		XS	S	M	L	XL	2XL	3XL	4XL	5XL	6XL
To fit waist size (cm)	72	77	82	87	92	97	102	107	112	117	122
To fit waist size (inches)	28	30	32	34	36	38	40	42	44	46	48
In-leg length (cm)	77	80	82	84	84	84	84	84	84	84	84

Size STOUT	87S	92S	97S	102S	107S	112S	117S	122S	127S	132S	
To fit waist size (cm)		87	92	97	102	107	112	117	122	127	132
To fit waist size (inches)		34	36	38	40	42	44	46	48	50	52
In-leg length (cm)		80	80	80	80	80	80	82	82	82	82

Size LONG	74L	79L	84L	89L	94L
To fit waist size (cm)	74	79	84	89	94
To fit waist size (inches)	29	31	33	35	37
In-leg length (cm)	84	86	88	88	88

JACKETS / JUMPERS & WET WEATHER GEAR

Size	XS	S	M	L	XL	2XL	3XL	4XL	5XL	6XL
To fit chest size (cm)	87	92	97	102	107	112	117	122	127	132
To fit chest size (inches)	34	36	38	40	42	44	46	48	50	52

OVERALLS

Sizes REGULAR	77R	82R	87R	92R	97R	102R	107R	112R	117R
To fit chest size (cm)	87	92	97	102	107	112	117	122	127
To fit chest size (inches)	34	36	38	40	42	44	46	48	50
To fit waist size (cm)	77	82	87	92	97	102	107	112	117
To fit waist size (inches)	30	32	34	36	38	40	42	44	46
In-leg length (cm)	76	78	80	80	80	80	80	80	80

Sizes STOUT	92S	97S	102S	107S	112S	117S	122S	127S	132S	
To fit chest size (cm)		102	107	112	117	122	127	132	137	142
To fit chest size (inches)		40	42	44	46	48	50	52	54	56
To fit waist size (cm)		92	97	102	107	112	117	122	127	132
To fit waist size (inches)		36	38	40	42	44	46	48	50	52
In-leg length (cm)		76	76	76	76	76	76	76	76	76

Sizes LONG	74L	79L	84L	89L	94L
To fit chest size (cm)	87	92	97	102	107
To fit chest size (inches)	34	36	38	40	42
To fit waist size (cm)	74	79	84	89	94
To fit waist size (inches)	29	31	33	35	37
In-leg length (cm)	80	82	84	84	84

Disclaimer: This editorial contains measurements and sizing that should be used as a guide only.

SEE PAGE 73 FOR THE WOMEN'S SIZE GUIDE



LONG SLEEVE COOL & DRILL SHIRTS

CLOTHING & FOOTWEAR

REFLECTIVE COOL LONG SLEEVE SHIRT



- Lightweight cool cotton, 160gsm
- Two button flap chest pockets, one with pencil opening
- Mesh air vents under back of collar and under arms
- Hi-vis reflective 3M Scotchlite™ taping
- Full button front
- Button cuffs



Mesh Air Vents



	NAVY	ORANGE	KHAKI
Size	Bishops Code	Bishops Code	Bishops Code
Small	55545402	55545468	55545418
Medium	55545404	55545469	55545420
Large	55545406	55545470	55545422
X-Large	55545408	55545471	55545424
2X-Large	55545410	55545472	55545426
3X-Large	55545412	55545473	55545428

REFLECTIVE COOL LONG SLEEVE 2 TONE SHIRT



- Lightweight cool cotton, 160gsm
- Full button front
- Two button flap chest pockets, one with pencil opening
- Mesh air vents under back of collar and under arms
- Hi-vis reflective 3M Scotchlite™ taping
- Button cuffs

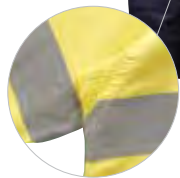
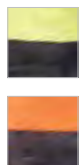

Mesh Air Vents



	YELLOW/NAVY	ORANGE/NAVY	YELLOW/NAVY	ORANGE/NAVY
Size	Bishops Code	Bishops Code	Size	Bishops Code
Small	55545434	55545450	2X-Large	55545442
Medium	55545436	55545452	3X-Large	55545444
Large	55545438	55545454	4X-Large	55545446
X-Large	55545440	55545456	-	-

HEAVY DUTY DRILL LONG SLEEVE 2 TONE SHIRT



- 100% cotton drill, 190gsm
- Full button front
- Two button flap chest pockets, one with pencil opening
- Double button cuff



	OLIVE/YELLOW	Size	OLIVE/YELLOW
Size	Bishops Code		Bishops Code
Small	55540897	X-Large	55540900
Medium	55540898	2X-Large	55540901
Large	55540899	3X-Large	55540902

REFLECTIVE LONG SLEEVE 2 TONE SHIRT



- 100% cotton drill, 190gsm
- Full button front
- Two button flap chest pockets, one with pencil opening
- Hi-vis reflective 3M Scotchlite™ taping
- Double button cuff

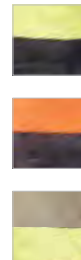

	YELLOW/NAVY	ORANGE/NAVY	OLIVE/YELLOW
Size	Bishops Code	Bishops Code	Bishops Code
Small	55545819	55545710	55545697
Medium	55545820	55545720	55545698
Large	55545840	55545740	55545699
X-Large	55545860	55545760	55545700
2X-Large	55545880	55545780	55545701
3X-Large	55545890	55545790	55545702
4X-Large	55545895	55545795	-

HEAVY DUTY DRILL LONG SLEEVE SHIRT



- 100% cotton drill, 190gsm
- Full button front
- Two button flap chest pockets, one with pencil opening
- Double button cuff



	NAVY	ORANGE	KHAKI	OLIVE
Size	Bishops Code	Bishops Code	Bishops Code	Bishops Code
Small	55540410	55540815	55540610	55540510
Medium	55540420	55540820	55540620	55540520
Large	55540440	55540840	55540640	55540540
X-Large	55540460	55540860	55540660	55540560
2X-Large	55540480	55540880	55540680	55540580
3X-Large	55540490	55540890	55540690	55540590
4X-Large	-	-	55540695	-

REFLECTIVE HEAVY DUTY DRILL LONG SLEEVE SHIRT



- 100% cotton drill, 190gsm
- Full button front
- Two button flap chest pockets, one with pencil opening
- Hi-vis reflective 3M Scotchlite™ taping
- Double button cuff



	NAVY	ORANGE	KHAKI	OLIVE	SKY BLUE
Size	Bishops Code	Bishops Code	Bishops Code	Bishops Code	Bishops Code
Small	55545310	55545915	55545210	55545110	55546005
Medium	55545320	55545920	55545220	55545120	55546006
Large	55545340	55545940	55545240	55545140	55546007
X-Large	55545360	55545960	55545260	55545160	55546008
2X-Large	55545380	55545980	55545280	55545180	55546009
3X-Large	55545390	55545990	55545290	55545190	55546010
4X-Large	-	-	55545295	-	55546011

HEAVY DUTY DRILL LONG SLEEVE SHIRT



- 100% cotton drill, 190gsm
- Full button front
- Two button flap chest pockets, one with pencil opening
- Double button cuff



	SKY BLUE		SKY BLUE
Size	Bishops Code	Size	Bishops Code
Small	55540701	2X-Large	55540705
Medium	55540702	3X-Large	55540706
Large	55540703	4X-Large	55540707
X-Large	55540704	-	-

HEAVY DUTY DRILL SHORT SLEEVE SHIRT



- 100% cotton drill, 190gsm
- Full button front
- Two button flap chest pockets, one with pencil opening



	NAVY	KHAKI	OLIVE
Size	Bishops Code	Bishops Code	Bishops Code
Small	55530010	55530210	55530110
Medium	55530020	55530220	55530120
Large	55530040	55530240	55530140
X-Large	55530060	55530260	55530160
2X-Large	55530080	55530280	55530180
3X-Large	55530090	55530290	55530190
4X-Large	55530095	-	55530195
5X-Large	55530100	-	-



SHORT SLEEVE DRILL & POLO SHIRTS

CLOTHING & FOOTWEAR

REFLECTIVE HEAVY DUTY DRILL SHORT SLEEVE SHIRT



- 100% cotton drill, 190gsm
- Full button front
- Two button flap chest pockets, one with pencil opening
- Hi-vis reflective 3M Scotchlite™ taping at critical areas



	NAVY	ORANGE	KHAKI
Size	Bishops Code	Bishops Code	Bishops Code
Small	55530400	55530440	55530420
Medium	55530402	55530442	55530422
Large	55530404	55530444	55530424
X-Large	55530406	55530446	55530426
2X-Large	55530408	55530448	55530428
3X-Large	55530410	55530450	55530430

REFLECTIVE HEAVY DUTY DRILL SHORT SLEEVE 2 TONE SHIRT



- 100% cotton drill, 190gsm
- Full button front
- Two button flap chest pockets, one with pencil opening
- Hi-vis reflective 3M Scotchlite™ taping

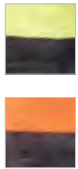

	YELLOW/NAVY	ORANGE/NAVY	YELLOW/NAVY	ORANGE/NAVY
Size	Bishops Code	Bishops Code	Size	Bishops Code
Small	55545615	55545515	X-Large	55545660
Medium	55545620	55545520	2X-Large	55545680
Large	55545640	55545540	3X-Large	55545690

HI-VIS 2 TONE POLO SHIRT



- 100% polyester
- One front pocket with pencil opening
- Fold down collar with three descending buttons
- Two tone stripe trims on collar and sleeves

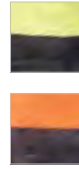

	ORANGE/NAVY	YELLOW/NAVY	ORANGE/NAVY	YELLOW/NAVY
Size	Bishops Code	Bishops Code	Size	Bishops Code
Small	55548180	55548100	X-Large	55548183
Medium	55548181	55548110	2X-Large	55548184
Large	55548182	55548120	3X-Large	55548185

HI-VIS REFLECTIVE 2 TONE POLO SHIRT



- 100% polyester
- One front pocket with small pen pocket
- Fold down collar with three descending buttons
- Two tone stripe trims on collar and sleeves
- Hi-vis reflective 3M Scotchlite™ taping

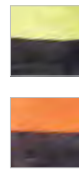

	YELLOW/NAVY	ORANGE/NAVY	YELLOW/NAVY	ORANGE/NAVY
Size	Bishops Code	Bishops Code	Size	Bishops Code
Small	55548162	55548190	X-Large	55548168
Medium	55548164	55548191	2X-Large	55548170
Large	55548166	55548192	3X-Large	55548172

REFLECTIVE HI-VIS 4 IN 1 OXFORD POLYESTER RAIN JACKET



- 100% polyester, PU coated
- Store away hood in the collar
- One mobile phone chest pocket
- Two large side pockets
- One accessory zip pocket on the left sleeve
- Adjustable velcro straps on each cuff
- Hi-vis reflective 3M Scotchlite™ taping
- Complies to standard AS/NZS 4602:1999 Class D/N



YELLOW		YELLOW	
Size	Bishops Code	Size	Bishops Code
Small	55510120	X-Large	55510126
Medium	55510122	2X-Large	55510128
Large	55510124	3X-Large	55510130

REFLECTIVE HI-VIS OXFORD POLYESTER RAIN JACKET



- 100% polyester PU coated breathable mesh
- Store away hood in the collar
- One mobile phone chest pocket
- Two large side pockets
- One accessory zip pocket on the left sleeve
- Adjustable velcro straps on each cuff
- Hi-vis reflective 3M Scotchlite™ taping
- Complies to AS/NZ 4602:1999 Class D/N



ORANGE		ORANGE	
Size	Bishops Code	Size	Bishops Code
Small	55510220	X-Large	55510226
Medium	55510222	2X-Large	55510228
Large	55510224	3X-Large	55510230

REFLECTIVE HI-VIS 4 IN 1 OXFORD POLYESTER 2 TONE RAIN JACKET



- 100% polyester, PU coated
- Store away hood in the collar
- One mobile phone chest pocket
- Two large side pockets
- One accessory zip pocket on the left sleeve
- Adjustable velcro straps on each cuff
- Hi-vis reflective 3M Scotchlite™ taping
- Complies to standard AS/NZS 4602:1999 Class D/N



ORANGE/NAVY		ORANGE/NAVY	
Size	Bishops Code	Size	Bishops Code
Small	55510100	X-Large	55510106
Medium	55510102	2X-Large	55510108
Large	55510104	3X-Large	55510110

REFLECTIVE HI-VIS OXFORD POLYESTER 2 TONE RAIN JACKET



- 100% polyester, PU coated
- Store away hood in the collar
- One mobile phone chest pocket
- Two large side pockets
- One accessory zip pocket on the left sleeve
- Adjustable velcro straps on each cuff
- Hi-vis reflective 3M Scotchlite™ taping
- Complies to standard AS/NZS 4602:1999 Class D/N



YELLOW/NAVY		YELLOW/NAVY	
Size	Bishops Code	Size	Bishops Code
Small	55510200	X-Large	55510206
Medium	55510202	2X-Large	55510208
Large	55510204	3X-Large	55510210



PVC RAINCOATS & PANTS

CLOTHING & FOOTWEAR

¾ LENGTH PVC RAINCOAT WITH HOOD



- Drawstring on hood
- Zip front
- Stud button closures
- Two pockets
- Available with or without reflective taping
- Yellow



NON-REFLECTIVE		REFLECTIVE TAPING	
Size	Bishops Code	Size	Bishops Code
Small	55010150	Small	55010250
Medium	55010160	Medium	55010260
Large	55010170	Large	55010270
X-Large	55010180	X-Large	55010280
2X-Large	55010185	2X-Large	55010282
3X-Large	55010190	3X-Large	55010284

¾ LENGTH PVC RAINCOAT WITH PANTS



- PVC trousers with elasticated waist
- Drawstring on hood
- Zip front
- Stud button closures
- Two pockets on jacket
- Yellow



Size	Bishops Code	Size	Bishops Code
Small	55010210	X-Large	55010240
Medium	55010220	2X-Large	55010242
Large	55010230	3X-Large	55010244

HIP LENGTH PVC RAINCOAT WITH HOOD



- Drawstring on hood
- Zip front
- Stud button closures
- Two pockets
- Yellow



Size	Bishops Code	Size	Bishops Code
Small	55010110	X-Large	55010140
Medium	55010120	2X-Large	55010142
Large	55010130	3X-Large	55010144

PVC RAIN PANTS



- Elasticated waist
- Plastic snap buttons on hems to adjust leg openings
- Yellow



Size	Bishops Code	Size	Bishops Code
Small	55010050	X-Large	55010065
Medium	55010055	2X-Large	55010070
Large	55010060	3X-Large	55010080



re going to make
the best gold mine
in the New Guinea.

QUALITY WORKWEAR FOR THE EVERYDAY HARDWORKING PEOPLE



HARDMAN
Workwear

SALES & SERVICE

PORT MORESBY 325 1088
LAE 472 3799
KIMBE 983 5500

MADANG
MT HAGEN
KOKOPO

422 1344
545 1990
982 9911

sales@bishopbros.com.pg
www.bishopbros.com.pg



RAIN PANTS, PONCHO & INSECT REPELLENT SHIRTS

CLOTHING & FOOTWEAR

REFLECTIVE OXFORD POLYESTER RAIN PANTS



- 100% polyester, PU coated
- Two pockets with velcro closure
- Zip fly with button top
- Elasticated waist with draw string
- Hi-vis reflective 3M Scotchlite™ tape below each knee
- Adjustable velcro straps around ankles
- Fitted with mesh lining internally



ORANGE

Size	Bishops Code
30	55510410
32	55510412
34	55510414
36	55510416
38	55510418
40	55510420

DISPOSABLE HOODED PONCHO

- Compact emergency rain coat with hood
- Single use
- One size fits all
- Grey



Item Code	Bishops Code
CG190	55510235

INSECT SHIELD FIELD SHIRT



IS-SUN3

- 60% cotton, 40% polyester, 3.5oz/120gsm
- 30+ UPF protection
- Lightweight shirt with vented back
- Long sleeves with button-tab for holding rolled up sleeves in place
- Two button cuffs
- Two velcro-close box pleat front pockets
- One velcro-close pocket on right sleeve
- Shirt-tail hem
- Light coloured horn-tone buttons
- Repels a variety of insects including mosquitoes, ticks, ants, flies, chiggers and midges (no-see-ums)
- Also available in khaki



BLUE

Size	Bishops Code	Size	Bishops Code
Small	55562600	X-Large	55562615
Medium	55562605	2X-Large	55562620
Large	55562610	3X-Large	55562622

INSECT SHIELD LONG SLEEVE TWILL WORK SHIRT



IS-ZS7

- 100% cotton, 4.8 oz twill
- Repels mosquitoes, ticks, ants, flies, chiggers and midges
- EPA-registered permethrin repellent built into the fabric
- Two front patch pockets with button closure
- Adjustable two-button cuff closure
- Shirt-tail hem



STONE

Size	Bishops Code	Size	Bishops Code
Small	55562150	2X-Large	55562158
Medium	55562152	3X-Large	55562160
Large	55562155	4X-Large	55562162
X-Large	55562156	-	-

GET MORE AT BISHOPS



INSECT REPELLENT SOCKS

Page 89



INSECT SHIELD REFLECTIVE LONG SLEEVE TWILL WORK SHIRT



IS-ZS7-HV

- 100% cotton, 4.4oz/150gsm twill
- Two chest pockets
- Two button cuffs
- Shirt-tail hem
- Hi-vis reflective taping at critical areas
- Repels a variety of insects including mosquitoes, ticks, ants, flies, chiggers and midges (no-see-ums)



MEDIUM BLUE

STONE

MEDIUM BLUE

STONE

Size	Bishops Code	Bishops Code	Size	Bishops Code	Bishops Code
Small	55562100	55562168	2X-Large	55562120	55562176
Medium	55562105	55562170	3X-Large	55562125	55562178
Large	55562110	55562172	4X-Large	55562130	-
X-Large	55562115	55562175	-	-	-

INSECT SHIELD REFLECTIVE LONG SLEEVE 2 TONE TWILL WORK SHIRT



IS-ZS10-HV

- 60% cotton, 40% polyester, 4.4oz/150gsm twill
- Two chest pockets
- Two button cuffs
- Shirt-tail hem
- Hi-vis reflective taping at critical areas
- Repels a variety of insects including mosquitoes, ticks, ants, flies, chiggers and midges (no-see-ums)



	YELLOW/ NAVY		ORANGE/ NAVY	
Size	Bishops Code	Bishops Code	Size	Bishops Code
Small	55562535	55562192	2X-Large	55562539
Medium	55562536	55562193	3X-Large	55562540
Large	55562537	55562194	4X-Large	55562198
X-Large	55562538	55562195	-	-

INSECT SHIELD WOMEN'S LONG SLEEVE TWILL WORK SHIRT



IS-ZS2

- 55% cotton 45% polyester, 4.8oz/160gsm twill
- Button down collar
- Repels a variety of insects including mosquitoes, ticks, ants, flies, chiggers and midges (no-see-ums)



	STONE		STONE	
Size	Bishops Code	Size	Bishops Code	
Small	55565150	X-Large	55565153	
Medium	55565151	2X-Large	55565154	
Large	55565152	3X-Large	55565155	

WOMEN'S SIZE GUIDE

MEASUREMENTS

- BUST:** Measure around the fullest part of the bust and shoulder, under the arms with your arms at resting position.
- NATURAL WAIST:** Measure over undergarments at the natural waistline (usually approx. 1cm above the navel).
- LOWER WAIST:** Measure over undergarments approx. 4cm below the natural waistline.
- HIP:** Measure over undergarments at hips (usually the widest part and is approx. 25cm below the waistline).
- IN-LEG:** Measure from crotch to floor, with shoes.

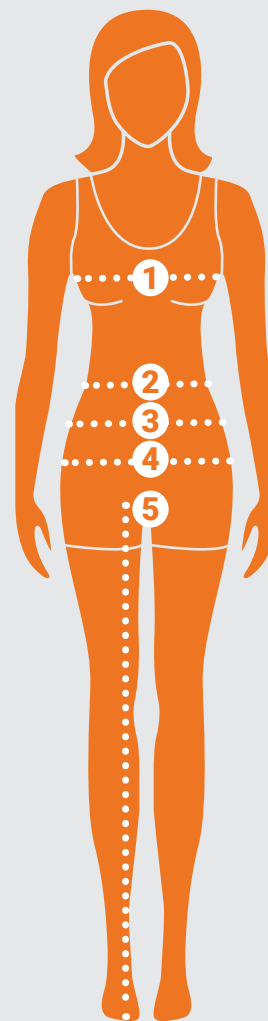

WOMEN'S Sizes

Size	6	8	10	12	14	16	18	20	22	24
To fit bust size (cm)	80	85	90	95	100	105	110	115	120	125
To fit natural waist size (cm)	60	65	70	75	80	85	90	95	100	105
To fit lower waist size (cm)	67	72	77	82	87	92	97	102	107	112
To fit hip size (cm)	87	92	97	102	107	112	117	122	127	132
In-leg length (cm)	75	75	77	77	80	80	80	80	80	80

Disclaimer: This editorial contains measurements and sizing that should be used as a guide only.



INSECT REPELLENT PANTS & JEANS

CLOTHING & FOOTWEAR

INSECT SHIELD CARGO PANTS



IS-VP5

- 100% cotton canvas, 7.5oz/250gsm
- Jean-style front pockets with right side coin pocket
- Cargo-style pockets on outside of each leg
- Back patch pockets with reinforced double layer
- Triple needle stitching at inseam
- Rivet reinforcement at front pockets
- Extra wide belt loops
- Repels a variety of insects including mosquitoes, ticks, ants, flies, chiggers and midges (no-see-ums)



Size	STONE	Size	STONE
REGULAR	Bishops Code	REGULAR	Bishops Code
30	55565130	38	55565134
32	55565131	40	55565135
34	55565132	42	55565136
36	55565133	44	55565137

INSECT SHIELD DENIM WORK JEANS



IS-KP2

- 100% cotton denim, 12oz/405gsm
- Antique brass button waistband
- Triple needle stitching
- Antique brass rivets on front pockets
- 5 pockets plus double utility pocket on right leg
- Hammer loop
- Reinforced front and hip pockets
- Repels a variety of insects including mosquitoes, ticks, ants, flies, chiggers and midges (no-see-ums)



Size	INDIGO	Size	INDIGO
REGULAR	Bishops Code	REGULAR	Bishops Code
30	55562200	38	55562230
32	55562210	40	55562235
34	55562220	42	55562240
36	55562225	-	-

INSECT SHIELD REFLECTIVE CARGO PANTS



IS-VP5-HV

- 100% cotton canvas, 7.5oz/250gsm
- Jean-style front pockets with right side coin pocket
- Cargo-style pockets on outside of each leg
- Back patch pockets with reinforced double layer
- Triple needle stitching at inseam
- Rivet reinforcement at front pocket
- Extra wide belt loops
- Hi-vis reflective taping at critical areas
- Repels a variety of insects including mosquitoes, ticks, ants, flies, chiggers and midges (no-see-ums)



Size	NAVY	STONE	Size	NAVY	STONE
REGULAR	Bishops Code	Bishops Code	REGULAR	Bishops Code	Bishops Code
30	55562362	55562325	40	55562369	55562350
32	55562364	55562330	42	55562370	55562355
34	55562366	55562335	44	55562371	-
36	55562367	55562340	46	55562372	-
38	55562368	55562345	48	55562373	-

BISHOPS

Bishops In-House Embroidery Services

Customise your workwear with company logos, employee names and more!

Contact Bishops Port Moresby & Lae branches to find out more.

Port Moresby (675) 325 1088 | Lae (675) 472 3799

FR & ARC FLASH CLOTHING

Flame Resistant (FR) garments are made from inherently fire resistant materials that self extinguish and provide thermal insulation protection for the wearer. FR rated clothing will provide the wearer a level of protection from an arc or flash fire incident, it is worth remembering they are not fire proof garments and are intended to minimise and reduce FR/arc flash injuries - not eliminate them.

It is highly recommended that workers who have the potential to be exposed to an FR/arc flash incident such as arc flashes (electricians, electric utility linemen, etc.), flash fires (refinery, chemical and pharmaceutical workers, etc.), or combustible dust (workers in food processing, paint and many more industries), plus workers who come in to contact with energised electrical equipment or radiant heat, should be wearing FR/arc rated clothing.

Arc flashes occur when an electrical current leaves its path and travels through the air from one conductor to another, causing an explosion. An arc flash can occur from accidental contact with electrical systems, build-up of conductive dust, corrosion, dropped tools or improper work procedures. Exposure to an arc flash can result in serious burn injuries or even death.

A flash fire occurs when air combines with a flammable substance and ignites. Flash fires have extremely high heat, a short duration and a rapidly moving flame. Flash fires are often catastrophic, causing extreme damage, injury and in some cases, death.

Garments offering FR/arc rated protection come in either a treated cotton or an inherent blend. Treated garments that offer flame resistance and arc flash protection will see their protection levels diminish with each wear and wash and are commonly used in short term projects. Inherent fabrics never lose their flame resistance or arc flash protection and are a more cost effective solution for long term wear.

Arc Thermal Performance Value (ATPV) is the minimum arc rating of the clothing, measured in calories per cm² (cal/cm²). The higher the value, the more insulated the garment is, therefore providing greater protection to the wearer.

What is an Arc Flash?

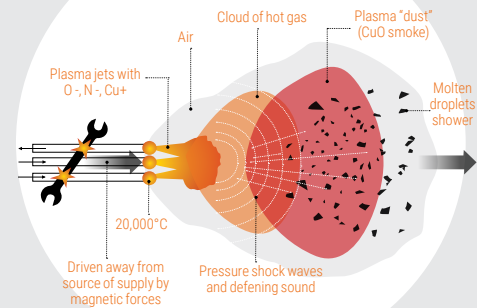

ASTM D6413 is the standard test method for flame resistance of textiles. A vertical flame test is used to determine the flame resistance of a garment and the material must pass the stipulated requirements of the test to comply with the standard, including after flame time, afterglow time and char length.

ASTM F1506 covers the performance specifications for flame resistant and electric arc protective clothing. Clothing that meets this standard covers the minimum requirements for this type of protective garment, including a range of tests that confirm a fabric's ability to protect the wearer.

IEC 61482 covers the requirements for garments designed to protect the wearer against thermal hazards from electric arcs. Clothing that claims to provide arc flash protection must conform to the requirements outlined in this standard.

AS/NZS 1020:1995 outlines recommendations relating to safe control of electrostatic charges generated incidentally by activities undertaken while wearing clothing. Garments meeting this standard will not create static electricity when worn.

PPE/Hazard Risk Categories (HRC) Categories

Employers should conduct a risk assessment to determine the level of protection employees need to wear when performing tasks involving electrical works. PPE levels are determined by testing electrical equipment to assess the potential of an explosion or arc flash. Like arc ratings, this is also measured in cal/cm². The equipment is then rated into a PPE category to ensure that the worker is wearing the appropriate protection from the potential energy that could be outputted in the case of an explosion or arc flash.

Arc Flash Boundaries

 LEVEL 1 The flash protection boundary can be greater than or less than the limited approach boundary.	 LEVEL 2 Limited Space	 LEVEL 3 Restricted Space	 LEVEL 4 Prohibited Space	ENCLOSURE Exposed Energized conductor or circuit part Zero Distance
 Limited Approach Boundary	 Restricted Approach Boundary	 Prohibited Approach Boundary		
PPE/Hazard Risk Category 1 FR/arc shirt and FR/arc pants or FR/arc coverall (1 layer). Min Arc Rating Required: 4 cal/cm ²	PPE/Hazard Risk Category 2 FR/arc shirt and FR/arc pants, FR/arc coverall or switching suit (1 or 2 layers). Min Arc Rating Required: 8 cal/cm ²	PPE/Hazard Risk Category 3 FR/arc switching suit (2 or 3 layers). Min Arc Rating Required: 25 cal/cm ²	PPE/Hazard Risk Category 4 FR/arc switching suit (3 or more layers). Min Arc Rating Required: 40 cal/cm ²	

Arc Flash Signage Example

- 1 Bus name or equipment name
- 2 Bus voltage level
- 3 Activity to be performed
- 4 Incident energy level
- 5 Hazard risk category/PPE
- 6 Arc flash boundary

				DANGER			
ARC FLASH HAZARD				<small>As per OCE, ENE, G01, 01</small>			
1	Equipment Name:	Coal Handling Plant #15V SWBD A Pass LS					
2	Voltage Level Volts	415	Fault Current, kA:	45.35			
3	DOOR OPEN Incident Energy Cal/cm ²	12.4	Arc Flash Boundary, m:	1.90			
4			6				
5	3		WARNING		Arc Flash Hazard Wear Category 3 PPE		

HEADER STAYS CONSTANT

INTERNAL MAY CHANGE

FOOTER STAYS CONSTANT



FLAME RESISTANT CLOTHING

CLOTHING & FOOTWEAR

INSECT SHIELD TECASAFE® FLAME RESISTANT REFLECTIVE WORK SHIRT



IS-VS4FR-HVE

- Tecasafe fabric: 48% modacrylic, 37% Lyocell, 15% Para-Aramid
- Repels mosquitoes, ticks, ants, flies, chiggers and midges
- EPA-registered permethrin repellent built into the fabric
- Flame resistant
- Hi-vis taping on upper arms
- Arc rating ATPV 9.0 calories/cm2 - NFPA 2112
- Long sleeve, button front
- Gusset side seam to allow ease of movement
- Banded topstitched collar
- Placket front with button closure



	NAVY		KHAKI	
Size	Bishops Code	Bishops Code	Size	Bishops Code
Small	55563292	55563280	X-Large	55563298
Medium	55563294	55563282	2X-Large	55563299
Large	55563296	55563284	3X-Large	55563290

CLOTHING STANDARDS

AS/NZS 1020:1995 outlines recommendations relating to safe control of electrostatic charges generated incidentally by activities undertaken while wearing clothing. Garments meeting this standard will not create static electricity when worn.

AS/NZS 1906.4:2010 specifies the requirements for high-visibility materials used in daytime, night time or other dark conditions. High visibility safety clothing should meet the requirements of this standard in order to provide adequate protection for the wearer.

AS/NZS 4399-1996 & AS/NZS 4399:2017 provides information on the capability of certain clothing materials to provide protection against ultraviolet radiation, including ultraviolet rays generated by the sun. Clothing that claims to provide UPF protection will need to conform to the requirements outlined in this standard.

ASTM F1506 covers the performance specifications for flame resistant and electric arc protective clothing. Clothing that meets this standard covers the minimum requirements for this type of protective garment, including a range of tests that confirm a fabric's ability to protect the wearer.

IEC 61482 covers the requirements for garments designed to protect the wearer against thermal hazards from electric arcs. Clothing that claims to provide arc flash protection must conform to the requirements outlined in this standard.

INSECT SHIELD TECASAFE® FLAME RESISTANT REFLECTIVE WORK PANTS



IS-VP3FR-HVE

- Tecasafe Fabric: 48% modacrylic, 37% Lyocell, 15% Para-Aramid
- Repels mosquitoes, ticks, ants, flies, chiggers and midges
- EPA-registered permethrin repellent built into the fabric
- Flame resistant
- Arc rating ATPV 10.1 calories/cm2 - HRC 2
- Waistband with button closure
- Two slack style front pockets
- Left back pocket with button closure
- Insect Shield logo over right rear pocket
- Hi-vis taping at legs



Size	NAVY	Size	NAVY
REGULAR	Bishops Code	REGULAR	Bishops Code
28	55563300	40	55563312
30	55563302	42	55563314
32	55563304	44	55563316
34	55563306	46	55563318
36	55563308	48	55563320
38	55563310	-	-

INSECT SHIELD TECASAFE® FIRE RETARDANT COVERALLS



FR-VC1A-HV

- 7oz/120gsm
- 45% modacrylic, 35% lyocell, 15% polyamide-imide, 5% aramid (navy only)
- 48% modacrylic, 37% lyocell, 15% para-aramid (tan and royal)
- HRC rating 2
- Arc rating ATPV 10.1cal/cm2
- Meets requirements of NFPA 2112
- One piece, top-stitched, lay-flat collar
- Two-way concealed Nomex® taped brass break-away zipper
- Concealed snap closures at top of zipper and neck and each cuff
- Elasticated waist
- Two front-swing pockets
- Two patch chest pockets, one with flap and concealed snap closure
- Two patch hip pockets
- Deep pleated action back
- Side vent opening
- EPA registered to last through 70 washes beyond the lifetime of most garments
- Repels a variety of insects including mosquitoes, ticks, ants, flies, chiggers and midges (no-see-ums)



	KHAKI
Size	Bishops Code
Small	55563230
Medium	55563234
Large	55563238
X-Large	55563242
2X-Large	55563246
3X-Large	55563250
4X-Large	55563254

FIRE RETARDANT DISPOSABLE COVERALLS



- Made from woodpulp and polyester
- Zip front with hood
- Elasticised wrist, waist and ankles
- Designed to be worn over, protect and extend the life of expensive primary thermal garments
- Protects against oil, grease and other substances
- Highly absorbent
- Strong breathable fabric
- Does not melt or drip when burnt
- Blue



Size	Bishops Code
Small	55520050
Medium	55520052
Large	55520053
X-Large	55520054
2X-Large	55520055
3X-Large	55520056

PROSHIELD® 20 COVERALLS



- CAT III Type 5 and 6 protection
- Breathable and lightweight SMS fabric
- Protection against non-hazardous particles, dirt and grime
- Suitable for low level protection requirements in warm climates
- Two piece hood with elasticated face seam
- Nylon zipper with protective flap
- Elasticated waist, ankles and wrists
- Stitched external seams
- Anti-static treatment
- Available in blue and white



WHITE		BLUE	
Item Code	Size	Item Code	Size
D15338118	Small	D15338174	Small
D15338122	Medium	D15338185	Medium
D15338134	Large	D15338191	Large
D15338149	X-Large	D15338209	X-Large
D15338157	2X-Large	D15338211	2X-Large
D15338160	3X-Large	D15338227	3X-Large
D15536392	4X-Large	D15536391	4X-Large

SPECIAL ORDER: PLEASE QUOTE ITEM CODE UPON ORDERING THIS PRODUCT

DISPOSABLE PAPER PE COATED COVERALLS



- Polypropylene spunbonded material
- Zip front with hood
- Elasticised wrist, waist and ankles
- Lightweight
- PE coating provides complete water, grease, oil and chemical resistance
- White



Size	Bishops Code
Small	55520005
Medium	55520010
Large	55520020
X-Large	55520030
2X-Large	55520035
3X-Large	55520040

TYVEK® 500 COVERALLS



- CAT III Type 5 and 6 protection
- High liquid and particulate protection including hazardous fine particles
- Good breathability thanks to air and moisture vapour permeability
- Overall ergonomic shape for perfect fit, comfort and protection when moving
- Tyvek® accessories also available in shoe covers, boot covers, sleeves, hoods, lab coats and aprons
- Xpert anti-static treatment on both sides, 500 Orange on inside
- Safety Orange option complies with EN ISO 20471 (High Visibility Clothing) for chromaticity and luminance
- TGA Listed ARTG IS 342911 (White Only)
- Complies with EN 14126 – Barrier to infective agents
- Complies with EN 1073-2 – Protection against radioactive contamination
- Complies with EN 1149-5 – Electrostatic properties (inductive charge)



XPERT – WHITE		SAFETY – ORANGE	
Item Code	Size	Item Code	Size
D14663953	Small	D15564072	Small
D14663967	Medium	D15564073	Medium
D14663977	Large	D15564074	Large
D14663986	X-Large	D15564075	X-Large
D14663997	2X-Large	D15564076	2X-Large
D14664003	3X-Large	D15564077	3X-Large
D1553613	4X-Large	D15564078	4X-Large

SPECIAL ORDER: PLEASE QUOTE ITEM CODE UPON ORDERING THIS PRODUCT



DIFFERENT TYPES OF COVERALLS: HOW THEY ARE TESTED AND WHEN TO WEAR THEM

Coveralls are a one-piece, loose-fitting suit that offers protection against outside contaminants over a large area of the body. Coveralls are essentially a full body protection suit, generally worn over the top of personal clothing. They can protect workers against a number of hazards, including hazards of a chemical, mechanical, thermal or biological nature. Coveralls can be made from numerous materials, offering differing resistance to many workplace hazards.

Coverall Standards

Coveralls are tested according to EN 14126, the standard which determines the performance requirements of protective clothing against infective agents. This standard focuses on the medium containing the bacteria or other infective agent, such as a liquid, aerosol or solid particulate and does not define performance requirements for specific infective agents. The standard consists of five tests which are conducted against fabrics only, and not the completed garment. This needs to be considered when selecting appropriate protective clothing for the workplace as hazards may be small enough to enter the suit through the opening of sewn seams for example, so welded seams may be the most suitable option. The 5 tests are;

- **ISO 16603:** Resistance to penetration by blood and bodily fluid using synthetic blood. This is a screening test which determines what pressure the ISO 16604 should be conducted under.
- **ISO 16604:** Resistance to penetration by blood-borne pathogens using a bacteriophage
- **EN ISO 22610:** Resistance to wet microbial penetration by biologically contaminated liquid
- **ISO/DIS 22611:** Resistance to liquid aerosol penetration by biologically contaminated liquid aerosols
- **ISO 22612:** Resistance to penetration by biologically contaminated dry, solid particles

Fabrics are given a class rating dependent on their performance in each of the above tests and how long it takes for the infective agent to penetrate the fabric, which can be found on their individual data sheets; the higher the class, the higher the level of protection. If the fabrics pass one of the above tests, they will be certified as EN 14126.

Type Classifications

Coveralls are subject to rigorous testing to determine their 'Type'. A coverall's Type indicates its suitability for certain environments and its level of protection against different hazards. Tests must comply with the above standards and will measure the coverall's performance against a number of variables including:

- Abrasions;
- Cracking;
- Tensile strength;
- Liquid repellence;
- Tear, puncture, chemical, ignition, spray and aerosol resistance.

Protective suits which have been constructed with EN 14126 compliant fabrics will then need to meet the requirements of their "Type" standard. Coveralls that have met the standards of their Type as well as the EN 14126 standard will be marked with the appropriate Type as well as "-b" which indicates that it is certified EN 14126.

Hazards

Hazards are divided into 3 categories

- **Category 1:** Minor hazards
- **Category 2:** Intermediate hazards
- **Category 3:** Serious or fatal hazards

EN 14126 - Protects against biologically contaminated particles, EN 14126.

EN 14126



EN 1149-5 - Electrostatic protection according to EN 1149-5 (with proper earthing).

EN 1149-5



EN 1073-2 - Protects against radioactive particle contamination in accordance with EN 1073-2 (not against radioactive radiation).

EN 1073-2



Type	Description	Relevant Standards
1a-B, 1b-B, 1c-B	Gas Tight	EN943-1:2002; EN943-2:2002
2-B	Non-Gas Tight	EN943-1:2002; EN943-2:2002
3-B	Protection Against Liquid	EN14605:2005 + A1:2009
4-B	Protection Against Liquid Spray	EN14605:2005 + A1:2009
5-B	Protection Against Airborne Particles	EN ISO 13982-1:2004 + A1:2010
6-B	Limited Protection Against Liquid Chemical Splash	EN 13034:2005 + A1:2009



Type 1: Gas Tight

Type 1 coveralls are gas tight and offer the highest level of protection against workplace hazards.

Type 1 suits are completely sealed against the environment, protecting the wearer against any chemical contamination in the form of either liquid or gas, as well as aerosols and solid particles. They are subjected to a test that ensures they are gas tight and are re-tested regularly. These coveralls are used in highly hazardous industrial environments and by emergency workers.



Type 2: Non-Gas Tight

Type 2 coveralls are non-gas tight. They prevent dust, liquids and vapours from entering the suit but must retain a positive pressure to do so. Type 2 suits, like Type 1 suits, are used in highly hazardous industrial areas and by emergency responders.



Type 3: Protection Against Liquid

Type 3 coveralls protect the wearer against liquids. They are tested by having strong jets of liquid blasted at weak points on the suit (seam joins, zip fastenings). Because of these testing requirements, suits of this nature require a barrier fabric and sealed seams.

Type 3 suits have a subcategory of classes which is determined by testing their breakthrough time; the amount of time it takes for liquid to enter the suit. Only a miniscule fraction of liquid is permitted to enter before it is deemed a failure. Lower end suits, Class 1, have a breakthrough time of 10 minutes with Class 6 suits on the higher end of the spectrum lasting for over 6 hours without liquid penetration.

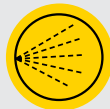

Type 4: Protection Against Liquid Spray

Type 4 overall suits offer protection against liquid spray and the saturation of liquids. Testing of this Type of coverall is similar to the testing carried out on Type 3 suits, however in this test, liquid is applied to the suit using less pressure and is then allowed to pool on and saturate the suit. During the test, the garment is subject to a shower of liquid over one minute while the subject wearing the suit rotates on a turntable. As with Type 3, this type of coverall requires welded seams so that no liquid can permeate through the suit and onto the wearer.



Type 5: Protection Against Airborne Particles

Type 5 overall suits protect the wearer against dust and dry particles. Type 5 coveralls are tested by having a subject perform exercise on a treadmill while a spray cabin is filled with dust. Particle counters inside the suit then calculate the amount of dust that enters the suit. They are suitable for industrial cleaning, site preparation, handling insulation and working with asbestos and are sometimes referred to as asbestos suits. When dealing with a hazard such as asbestos, it is important that workers are completely covered in reliable asbestos clothing gear to avoid the risk of contamination. It is also important that the suits are disposable because, if they have come into contact with asbestos, they should be destroyed as decontamination cannot be guaranteed.



Type 6: Protection Against Liquid Chemical Splash

Type 6 coveralls protect the wearer against light spray and splashes. They are similar to Type 3 and Type 4 suits however they are tested with a lighter spray of liquid which is not permitted to build up on the suit. In this instance, the subject rotates on a turntable as four nozzles spray liquid on to the suit and afterwards the inside of the suit is checked for any penetration. Dependent on the testing criteria and the amount of liquid inside the suit, it will be classed as a pass or a fail. They offer the lowest level of protection and should only be worn in low risk environments.

Coveralls With Multiple Types

Multiple Type numbers mean the coverall is a suitable form of protection against a variety of hazards and has met the criteria across multiple tests.

For instance, coveralls that are rated as Type 5/6 have passed the testing criteria for both Type 5 coveralls and Type 6 coveralls. This means they offer protection against all the hazards both types protect against.

TYVEK® 400 DUAL COVERALLS

- CAT III Type 5 and 6 protection
- Tyvek® fabric on front and arms
- Large breathable SMS back panel from head to ankle for increased comfort
- Tyvek® zipper and protective flap
- External stitched seams for enhanced protection against penetration from the outside to the inside of the garment
- Three piece hood with elasticated face seam
- Elasticated waist, wrists and ankles
- Suitable for asbestos removal, construction, mining, insulation and waste management
- White



Item Code	Size	Bishops Code	Item Code	Size	Bishops Code
D14809606	Small	*D14809606	D14809637	X-Large	55520063
D14809610	Medium	55520061	D14809645	2X-Large	55520064
D14809622	Large	55520062	D14809658	3X-Large	55520065

* - SPECIAL ORDER: PLEASE QUOTE ITEM CODE UPON ORDERING THIS PRODUCT

TYCHEM® 2000 COVERALLS

- CAT III Type 3, 4, 5 and 6 protection
- Tyvek® fabric with specialised polymeric coating
- Hood with elasticated face seam and adhesive chin flap
- Double self adhesive zipper flap offers high level protection
- Elasticated waist, ankles and wrists
- Protective seams are stitched and over taped with barrier tape providing barrier performance equal to that of the fabric
- Anti-static treatment on inside
- Provides protection against numerous concentrated inorganic chemicals and biohazards
- Yellow



Item Code	Size	Bishops Code	Item Code	Size	Bishops Code
D13675305	Small	*D13675305	D13675336	X-Large	55520075
D13675315	Medium	55520076	D13675340	2X-Large	55520077
D13675324	Large	55520074	D13675352	3X-Large	55520078

* - SPECIAL ORDER: PLEASE QUOTE ITEM CODE UPON ORDERING THIS PRODUCT

TYCHEM® 6000 F PLUS COVERALLS

- CAT III Type 3, 4, 5 and 6 protection
- Tychem® 6000 F Plus lightweight and durable fabric
- Elasticated hood with outer adhesive flap
- Double zipper system with self-adhesive zipper flap offers high level protection
- Elasticated wrists, ankles and waist
- Double knitted inner cuffs with thumb loops
- Protective seams are stitched and over-taped with barrier tape providing barrier performance equal to that of the fabric
- Antistatic treatment on inside
- Provides protection against numerous toxic industrial organic chemicals, highly concentrated inorganic chemicals and biohazards
- Chemical permeation data available for over 250 chemicals
- Grey



Item Code	Size	Item Code	Size
D15344179	Medium	D15344201	2X-Large
D15344186	Large	D15344210	3X-Large
D15344191	X-Large	-	-

SPECIAL ORDER: PLEASE QUOTE ITEM CODE UPON ORDERING THIS PRODUCT

BOUFFANT CAP HAIR NET



- Lightweight non-woven paper for comfort, hygiene and cleanliness
- 100 per bag
- White



Item Code	Bishops Code
SE1641	55580100

SHOE COVER



- Non-woven polypropylene spun-bonded material
- Elasticated top
- Keeps shoes clean and protected from damp and dirty surroundings
- One size fits most
- Blue
- Sold in pairs



Item Code	Bishops Code
SHOE COVER	55580410

PVC APRONS

- Durable PVC
- Blood, oil and fat resistant
- Offers some chemical resistance
- Full length fit for extra body protection
- Flexible and lightweight
- Dimensions: 1,200(l) x 900(w)mm



Colour	Bishops Code
White	55010025
Black	55010030
Blue	55010035

NYLON SNAKE GAITERS

- Heavy-duty waterproof green nylon
- Quick release webbing straps
- 25 mm heavy duty webbing with quick release buckle
- Full double thickness Hide leather lining



Colour	Bishops Code
Green	55090550



CHAINSAW PROTECTION, SUPPORT BELTS & HI-VIS VESTS

CLOTHING & FOOTWEAR

PPE CHAINSAW CHAPS



- 9 layers of leg protection in front and 5cm overlap of outer seam of left leg and inner seam of right leg
- Adjustable waist up to 116cm (46")
- Length: 86cm (34")



Item Code	Bishops Code
CXTWM103S	55090500

CHAINSAW PROTECTION KIT



Kit Includes:

- Forestry Helmet Set – Complies to EN397, EN352, EN1731
- Chainsaw Protective Gloves – Complies to EN381-7, class 1,20m/s
- Chainsaw Protective Chaps – Complies to EN381-5, class 1,20m/s
- Safety Glasses – Complies to EN166

Forestry Helmet Set

- Provides protection against flying particles
- Adjustable headgear
- Black brim provides overhead glare protection
- Standard brim hard hat
- Extra long padded headband for extended comfort earmuffs
- Economical cape



Chainsaw Protective Chaps

- 9 Layers of leg protection in front and 5cm overlap of outer seam of left leg and inner seam of right leg
- Adjustable waist up to 116cm (46")
- Length: 86cm (34")



Item Code	Bishops Code
KM15-4S010B	55045092

BACK SUPPORT BELT



- Easily adjustable elastic
- Tapered abdominal section for comfort
- Velcro closures



Size	Bishops Code
Medium – 32"–38"	55580710
Large – 38"–47"	55580720
X-Large – 46"–56"	55580730

REFLECTIVE HI-VIS NYLON DAY/NIGHT VEST



- More durable than mesh vests
- Ideal for printing company name or logo
- Hi-vis reflective 3M Scotchlite™ taping in H-pattern



	YELLOW	ORANGE	GREEN
Size	Bishops Code	Bishops Code	Bishops Code
Small	55010384	55010345	55010320
Medium	55010385	55010350	55010321
Large	55010390	55010355	55010322
X-Large	55010395	55010360	55010323
2X-Large	55010396	55010365	55010324
3X-Large	55010397	55010370	55010325
4X-Large	55010398	55010375	55010326
5X-Large	55010399	55010380	–

REFLECTIVE AIRTEX MESH SAFETY DAY/NIGHT VEST



- Lightweight mesh
- Breathable and comfortable
- Hi-vis reflective 3M Scotchlite™ taping in H-pattern
- Green



	GREEN		GREEN	
Size	Bishops Code	Size	Bishops Code	
Small	55010304	X-Large	55010300	
Medium	55010303	2X-Large	55010301	
Large	55010299	3X-Large	55010302	

HI-VIS AIRTEX MESH SAFETY DAY VEST



- Lightweight mesh
- Breathable and comfortable
- Hi-vis colour will help you stand out near high traffic and job site areas



	ORANGE	GREEN		ORANGE	GREEN
Size	Bishops Code	Bishops Code	Size	Bishops Code	Bishops Code
Small	55010306	–	X-Large	55010309	55010315
Medium	55010307	55010313	2X-Large	55010310	55010316
Large	55010308	55010314	3X-Large	–	55010317

FOOTWEAR

Australian Protective Footwear Standards

The Australia and New Zealand safety standard AS/NZS 2210 provides information and recommendations on the correct application of safety, protective and occupational footwear. Safety boots and shoes should comply with the standard and pass the minimum requirements if they are to be used in Australia and New Zealand. This standard is broken up into five subsections.

AS/NZS 2210.1:2010 provides a guide to the selection, care and use of safety, protective and occupational footwear.

AS/NZS 2210.2:2019 provides information on testing methods for safety footwear and the requirements to pass the tests.

AS 2210.3:2019:2019 stipulates basic requirements for safety footwear. Footwear that conforms to this standard must be fitted with safety toe caps that meet the minimum impact and compression resistance requirements. Toe caps must be resistant to 200 joules of impact force and be able to withstand a compression load of 15 kilonewtons.

AS/NZS 2210.4:2010 specifies basic requirements for protective footwear, as a lower level of protection than safety footwear. To conform to this standard, footwear must be fitted with toe caps that can withstand 100 joules of impact force and a 1 kilonewton compression load.

AS/NZS 2210.5:2009 specifies basic requirements for occupational footwear. Minimum requirements for this type of shoe does not include a safety toe cap, but does include other protective features, including slip and abrasion resistance.

EN ISO 20345 covers basic requirements and optional extras for general purpose safety footwear, including but not limited to slip resistance, thermal risks and mechanical risks.

Risk Assessment

It is important that the correct safety footwear is worn in relation to the work environment and tasks being undertaken. Hazard assessments should be performed at a worksite to determine the injury potential and the required protection for workers.

In relation to safety footwear, a risk assessment should consider:

- Environmental factors including temperature and surface conditions
- Risk of objects falling on the foot
- Equipment or materials used by the worker
- Sharp objects that may cut or penetrate the foot from the top, side or bottom
- Possible risks due to static electricity discharge, including explosives, flammable materials and sensitive electrical equipment
- Potential exposure to hazardous chemicals or substances
- Potential exposure to extreme temperatures

Key Components of Safety Footwear

STEEL TOE CAPS

Toe protection in safety footwear comes in either a steel toe cap or a composite toe cap. Both styles comply with the AS 2210.3:2019 safety standard, but steel cap boots are the most common style as they are mandatory in many workplaces. Each style of toe cap has their own benefits and limitations.



COMPOSITE TOE CAP

Pros

- Significantly lighter with superior flexibility
- Excellent thermal regulation – insulates against hot and cold
- Protects against spark ignition
- Rebounds after vertical or roll compression
- Airport friendly
- Can be X-rayed

Cons

- Average puncture resistance
- Can be more expensive



STEEL TOE CAP

Pros

- Cut resistant to power saw
- Puncture resistant to nail gun
- Prevents injury from falling objects up to a drop force of 200 joules

Cons

- Heavier than composite toe caps
- Need to be removed for airport security checks

Different Outer Soles

Understanding the difference between Thermoplastic Urethane (TPU) and nitrile rubber outsoles will help you choose the correct footwear for your working conditions.



TPU outsoles will suit most work environments. They are non-slip, resistant to most oils and chemicals and have a high tolerance to abrasion, splitting, cracking and cuts and tears. A TPU sole will withstand heat up to 130°C and is a more flexible and lightweight material than its counterparts.



Nitrile rubber outsoles are great for working in or around extreme temperatures as they are heat resistant up to 300°C and cold resistant down to -30°. They also provide premium chemical resistance, non-slip capabilities and resistance against abrasion, splitting, cracking and cuts and tears. The slip resistance of nitrile rubber outsoles improves the more they are worn and they also help reduce static electricity build up.



GUMBOOTS

NON-SAFETY PVC GUMBOOTS

- Suitable for general purpose applications
- Boot height: 360–400mm depending on size
- PVC
- Black

CLOTHING & FOOTWEAR



Size	Bishops Code	Size	Bishops Code	Size	Bishops Code
5	55025010	8	55025030	12	55025050
6	55025015	9	55025035	13	55025055
6.5	55025020	10	55025040	–	–
7	55025025	11	55025045	–	–

HERCULES PVC STEEL TOE GUMBOOTS

- Anti-perforation steel midsole and steel toecap for 200 joules
- Reinforced textile lining provides more ventilation, comfort and durability
- Heel energy absorption and a cleated sole for extra grip and anti-slipping
- Waterproof and anti-static
- Oil and fuel-resistant sole
- Reinforced pre-mould extra pad protection on back heel and front
- AS/NZS 2210.3 certified
- Boot height: 390mm

SAFETY JOGGER
SAFETY SHOES



Size	Bishops Code	Size	Bishops Code	Size	Bishops Code
5	55025110	8	55025140	12	55025170
6	55025120	9	55025145	13	55025180
7	55025135	10	55025150	–	–
7.5	55025137	11	55025160	–	–



RUBBER STEEL TOE GUMBOOTS

- Steel toe cap
- Hi-vis orange panels for added safety
- Soft top with drawstring to prevent dirt and debris entering the boot
- Ridged heel cap for added protection and easy on-and-off
- Non-slip sole



Size	Bishops Code	Size	Bishops Code	Size	Bishops Code
6	55025210	8	55025230	10	55025240
7	55025220	8.5	55025232	-	-
7.5	55025225	9	55025235	-	-

CAUSTIC RESISTANCE

Some safety boots offer protection against caustic chemicals that damage most materials that they come into contact with. Footwear that meets **EN 13832-2:2018** will provide protection against prolonged continuous contact with specific chemicals.

To meet this safety standard, chemical resistant footwear must prove resistance to at least two approved chemicals under laboratory conditions. The chemicals include sodium hydroxide 30%, sulphuric acid 95% and nitric acid 65%, among many others.

ELECTRICAL HAZARD AND ANTI-STATIC

Many safety boots have electrical protective properties that help to keep the wearer safe in electrical environments. The two varieties of electrical protection are electrical hazard resistant (also known as insulating) and anti-static.



Anti-static: Footwear which dissipates static electricity build up on the body by conducting it through the soles of the boots and into the ground. This provides protection against ignition hazards, such as flammable gases.



Electrical hazard resistant/insulating: Non-conductive footwear that is designed to help protect the wearer from hazardous step potential by reducing the amount of electricity conducted through the shoes. Only to be used as a supplemental form of electrical protection in conjunction with primary protective equipment, and not to be used if the wearer requires anti-static properties.

Safety standard ASTM F2413-18 covers the minimum design, performance, testing and classification requirements for safety footwear, and includes the minimum requirements for electrical hazard and anti-static footwear.



ELASTIC SIDED BOOTS

CLOTHING & FOOTWEAR

BRUT BLACK ELASTIC-SIDED STEEL TOE SAFETY BOOTS

- Full grain leather
- Certified to AS/NZ 2210.3
- Easy grip pull-on tabs
- Comfort Walk system
- Poron innersole and Thermolite linings
- Dual density Polyurethane and rubber sole for extra comfort and increased wear
- Wide safety steel toe cap
- Oil and heat resistant sole to 300°C



Size	Bishops Code	Size	Bishops Code	Size	Bishops Code	Size	Bishops Code	Size	Bishops Code
5	55030300	7	55030320	8.5	55030335	10	55030350	13	55030380
6	55030310	7.5	55030325	9	55030340	11	55030360	-	-
6.5	55030315	8	55030330	9.5	55030345	12	55030370	-	-

BRUT CLARET ELASTIC-SIDED STEEL TOE SAFETY BOOTS

- Quality Kip leather
- Certified to AS/NZ 2210.3
- Easy grip pull-on tabs
- Comfort Walk system
- Poron innersole and Thermolite linings
- Dual density Polyurethane and rubber sole for extra comfort and increased wear
- Wide safety steel toe cap
- Oil and heat resistant sole to 300°C



Size	Bishops Code	Size	Bishops Code	Size	Bishops Code	Size	Bishops Code	Size	Bishops Code
5	55030200	7	55030220	8.5	55030235	10	55030250	13	55030280
6	55030210	7.5	55030225	9	55030240	11	55030260	-	-
6.5	55030215	8	55030230	9.5	55030245	12	55030270	-	-

412471 KALAHARI ELASTIC SIDE SAFETY BOOTS WITH TPU SOLE



- This light, unlined boot is soft on your feet allowing for easy pull on/off
- Great for light, general-purpose work
- 200J steel toe cap and bump cap
- Pull-on style
- Woven pull-loops
- Elastic sided
- Buffalo barton water resistant pebbled leather
- EVA footbed with poly mesh cover
- Anti-static footbed
- PU injection anti-static midsole
- TPU anti-static outsole
- Colour: Black

Complies With:

- AS 2210.3:2019
- ASTM F2413
- EN ISO 20345



Size	Bishops Code	Size	Bishops Code	Size	Bishops Code
5	55036605	8	55036630	11	55036660
6	55036610	8.5	55036635	12	55036670
6.5	55036615	9	55036640	13	55036675
7	55036620	9.5	55036645	-	-
7.5	55036625	10	55036650	-	-

412452 KOKODA ELASTIC SIDE SAFETY BOOTS WITH TPU SOLE



- Elastic sides allow easy pull on/off, making this lined boot ideal for light industry and rural work
- Buffalo waxy or suede water resistant leather
- Fully-lined with poly mesh
- 200J steel toe cap
- Anti-static
- Woven pull-loops
- Elastic sided
- EVA footbed with poly mesh cover
- Anti-static footbed
- PU injection anti-static midsole
- TPU anti-static outsole
- Colour: Brown

Complies With:

- AS 2210.3:2019
- ASTM F2413
- EN ISO 20345



Size	Bishops Code	Size	Bishops Code	Size	Bishops Code
5	55036905	7.5	55036925	10	55036950
6	55036910	8	55036930	11	55036960
6.5	55036915	8.5	55036935	12	55036970
7	55036920	9	55036940	13	55036975

GET MORE AT BISHOPS ▶



BOOT LACES

Page 89

BOOT CLEANERS

Page 404



SAFETY GLASSES

From Page 12



GLOVE GRABBA

Page 8





LACE-UP BOOTS

CLOTHING & FOOTWEAR

NUBUCK LACE-UP 6" STEEL TOE SAFETY BOOTS

- Nubuck leather
- Certified to AS/NZ 2210.3
- Poron innersole
- Dual density Polyurethane and rubber sole
- Wide safety steel toe cap
- Full width tongue
- Heat resistant to 300°C
- Steel midsole
- Slip resistant
- Padded collar
- Brown



Size	Bishops Code	Size	Bishops Code	Size	Bishops Code	Size	Bishops Code	Size	Bishops Code
5	55036010	7	55036030	8.5	55036045	10	55036060	11.5	55036075
6	55036020	7.5	55036035	9	55036050	10.5	55036065	12	55036080
6.5	55036025	8	55036040	9.5	55036055	11	55036070	13	55036090

312102 ARGYLE® LACE-UP SAFETY BOOTS WITH TPU SOLE



- Lace up safety ankle boot
 - 200J Steel toe cap
 - Padded collar and tongue
 - TPU outsole heat resistant to 130°C
 - Directly moulded polyurethane midsole for greater shock absorption
 - Anti-static sole
 - Premium water resistant leather stitched with nylon thread
 - Trisole® Comfort Technology specially designed to cushion, cradle and support the entire foot from heel to toe
 - Endorsed by the Australian Physiotherapy Association
 - 7 eyelets
 - Height: 150mm
 - Colour: Black
- Complies With:**
- AS 2210.3:2019
 - ASTM F2413
 - EN ISO 20345



Size	Bishops Code	Size	Bishops Code
3	*312102-BL-030	9.5	55037540
4	*312102-BL-040	10	55037545
5	*312102-BL-050	10.5	55037550
5.5	*312102-BL-055	11	55037555
6	55037505	11.5	55037560
6.5	*312102-BL-065	12	55037565
7	55037515	12.5	*312102-BL-125
7.5	*312102-BL-075	13	55037575
8	55037525	13.5	*312102-BL-135
8.5	55037530	14	*312102-BL-140
9	55037535	-	-

* - SPECIAL ORDER: PLEASE QUOTE ITEM CODE UPON ORDERING THIS PRODUCT

382102 ARGYLE® LACE-UP SAFETY BOOTS WITH TPU SOLE



- Lace up safety ankle boot
 - 200J Steel toe cap and bump cap
 - Padded collar and tongue
 - TPU outsole heat resistant to 130°C
 - Directly moulded polyurethane midsole for greater shock absorption
 - Anti-static sole
 - Premium water resistant leather stitched with nylon thread
 - Trisole® Comfort Technology specially designed to cushion, cradle and support the entire foot from heel to toe
 - Endorsed by the Australian Physiotherapy Association
 - 7 eyelets
 - Height: 150mm
 - Colour: Black
- Complies With:**
- AS 2210.3:2019
 - ASTM F2413
 - EN ISO 20345



Size	Bishops Code	Size	Bishops Code
4	*382102-040-BLK	9.5	55037777
5	55037769	10	55037778
6	55037770	10.5	55037779
6.5	*382102-065-BLK	11	55037780
7	55037772	11.5	*382102-115-BLK
7.5	*382102-075-BLK	12	55037782
8	55037774	12.5	*382102-125-BLK
8.5	55037775	13	55037784
9	55037776	14	*382102-140-BLK

* - SPECIAL ORDER: PLEASE QUOTE ITEM CODE UPON ORDERING THIS PRODUCT

TPU OR NITRILE OUTSOLE? LET YOUR JOB DECIDE!

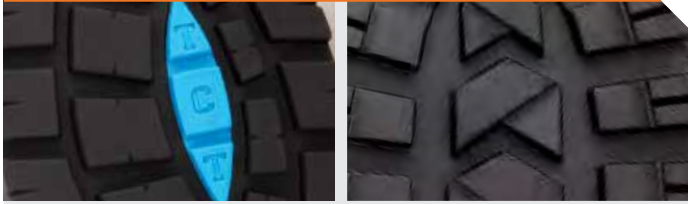

TPU Outsole

- Heat resistant to temperatures of 130°C (266°F)
- Highly resistant to most oils and chemicals
- High tolerance against abrasion, splitting, cracking and cuts/tearing
- Premium slip resistant capability

Nitrile Rubber Outsole

- Extreme heat tolerance – up to 300°C (572°F)
- Premium resistance to oil, mild acids, alkalis and animal fats
- Superior resistance to abrasion, splitting and cracking
- Premium cut resistance, tear strength and slip resistant capability (improves with wear)



As a general guide, TPU is the all-rounder and Nitrile is the premium specialist outsole marked with our easy guide icon.

382102 ARGYLE® LACE-UP SAFETY BOOTS WITH NITRILE OUTSOLE & BUMP CAP



- Lace-up safety ankle boot
- 200J Steel toe cap with durable polyurethane bump cap
- Padded collar and tongue
- Nitrile outsole, heat resistant to 300°C
- Directly moulded polyurethane midsole for greater shock absorption
- Penetration resistant midsole
- Premium water resistant leather stitched with nylon thread
- Anti-static sole
- Trisole® Comfort Technology specially designed to cushion, cradle and support the entire foot from heel to toe
- Endorsed by the Australian Physiotherapy Association
- 7 eyelets
- Height: 150mm
- Colour: Black



Complies With:

- AS 2210.3:2019
- ASTM F2413
- EN ISO 20345



Size	Bishops Code	Size	Bishops Code
4	*382102-040-BLK	9.5	*382102-095-BLK
5	55037769	10	55037778
6	55037770	10.5	55037779
6.5	*382102-065-BLK	11	55037780
7	55037772	11.5	*382102-115-BLK
7.5	*382102-075-BLK	12	55037782
8	55037774	12.5	*382102-125-BLK
8.5	55037775	13	55037784
9	55037776	14	*382102-140-BLK

* - SPECIAL ORDER: PLEASE QUOTE ITEM CODE UPON ORDERING THIS PRODUCT

412453 SIMPSON LACE-UP HIGH-LEG SAFETY BOOTS WITH TPU SOLE



- This heavy duty, lace-up boot provides extra ankle support
- The high leg offers protection beyond the ankle when working in muddy, sludgy conditions
- Buffalo waxy or suede water resistant leather
- Suede tongue
- Fully-lined with poly mesh
- 200J steel toe cap
- Anti-static
- PU foam padded collar
- EVA footbed with poly mesh cover
- Anti-static footbed
- PU injection anti-static midsole
- TPU anti-static outsole



Complies With:

- AS 2210.3:2019
- ASTM F2413
- EN ISO 20345



BLACK				BROWN			
Size	Bishops Code	Size	Bishops Code	Size	Bishops Code	Size	Bishops Code
5	*412453-BLK-050	9	55037040	5	*412453-BRN-050	9	55037140
6	55037010	10	55037050	6	55037110	9.5	55037145
6.5	55037015	11	55037060	6.5	55037115	10	55037150
7	55037020	12	55037070	7	55037120	11	55037160
7.5	55037025	13	55037075	7.5	55037125	12	55037170
8	55037030	14	*412453-BLK-140	8	55037130	13	55037175
8.5	55037035	-	-	8.5	55037135	14	*412453-BRN-140

* - SPECIAL ORDER: PLEASE QUOTE ITEM CODE UPON ORDERING THIS PRODUCT

312158 PARKES ZIP-UP SAFETY BOOTS WITH TPU SOLE



- Lace-up and zip sided safety ankle boot
- 200J Steel toe cap
- Padded collar and tongue
- TPU outsole heat resistant to 130°C
- Directly moulded polyurethane midsole for greater shock absorption
- Anti-static sole
- Premium water resistant leather stitched with nylon thread
- Trisole® Comfort Technology specially designed to cushion, cradle and support the entire foot from heel to toe
- Industrial grade side zip for easy, quick access
- Endorsed by the Australian Physiotherapy Association
- 6 eyelets
- Height: 95mm
- Colour: Wheat



Complies With:

- AS 2210.3:2019
- ASTM F2413
- EN ISO 20345



Size	Bishops Code	Size	Bishops Code
4	*312158-WH-040	9.5	*312158-WH-095
5	*312158-WH-050	10	55037645
6	55037605	10.5	*312158-WH-105
6.5	*312158-WH-065	11	55037655
7	55037615	11.5	*312158-WH-115
7.5	*312158-WH-075	12	55037665
8	55037625	12.5	*312158-WH-125
8.5	*312158-WH-085	13	*312158-WH-130
9	55037635	14	*312158-WH-140

* - SPECIAL ORDER: PLEASE QUOTE ITEM CODE UPON ORDERING THIS PRODUCT



ZIP-UP BOOTS

EXPLORER X ZIP-UP 8" STEEL TOE SAFETY BOOTS

- Quality Kip leather
- Certified to AS/NZ 2210.3
- Comfort Walk system
- Poron innersole and ThermoLite linings
- Dual density Polyurethane and rubber sole
- Wide safety steel toe cap
- Full width tongue to top of boot
- Oil and heat resistant sole to 300°C
- Steel midsole
- Slip resistant
- Padded collar
- Brown claret



CLOTHING & FOOTWEAR



Size	Bishops Code	Size	Bishops Code	Size	Bishops Code	Size	Bishops Code
6	55036210	8	55036230	9.5	55036245	12	55036270
7	55036220	8.5	55036235	10	55036250	13	55036280
7.5	55036225	9	55036240	11	55036260	-	-

312661 SOUTHERN CROSS® ZIP-UP SAFETY BOOTS WITH TPU SOLE

- Lace-up and zip ankle safety boot
- 200J steel toe cap with abrasion resistant scuff cap
- Padded collar and tongue
- Scalloped collar for ease of movement
- TPU outsole heat resistant to 130°C
- Directly moulded polyurethane midsole for greater shock absorption
- Anti-static sole
- Premium water resistant leather stitched with nylon thread
- Trisole® Comfort Technology specially designed to cushion, cradle and support the entire foot from heel to toe
- Industrial grade side zip for easy on and easy off
- Endorsed by the Australian Physiotherapy Association
- Height: 150mm
- Colour: Wheat



- Complies With:**
- AS 2210.3:2019
 - ASTM F2413
 - EN ISO 20345



Size	Bishops Code	Size	Bishops Code
4	*312661-WH-040	9.5	55037740
5	55037700	10	55037745
6	55037705	10.5	55037750
6.5	55037710	11	55037755
7	55037715	11.5	*312661-WH-115
7.5	55037720	12	55037765
8	55037725	12.5	*312661-WH-125
8.5	55037730	13	55037767
9	55037735	14	*312661-WH-140

* - SPECIAL ORDER: PLEASE QUOTE ITEM CODE UPON ORDERING THIS PRODUCT

412494 CANYON ZIP-UP SAFETY BOOTS WITH TPU SOLE

- This boot includes an added side zip for a quick fit and easy take on/off while still offering the support of a standard ankle boot
- Buffalo waxy or suede water resistant leather
- Suede tongue
- Fully-lined with poly mesh
- Zip sided lace-up
- Padded collar
- 200J steel toe cap
- Anti-static
- EVA footbed with poly mesh cover
- Anti-static footbed
- PU injection anti-static midsole
- TPU anti-static outsole



- Complies With:**
- AS 2210.3:2019
 - ASTM F2413
 - EN ISO 20345



BLACK				WHEAT			
Size	Bishops Code	Size	Bishops Code	Size	Bishops Code	Size	Bishops Code
5	55037205	8.5	55037240	5	55037300	8.5	55037335
6	55037215	9	55037245	6	55037310	9	55037340
6.5	55037220	10	55037255	6.5	55037315	10	55037350
7	55037225	11	55037265	7	55037320	11	55037360
7.5	55037230	12	55037275	7.5	55037325	12	55037370
8	55037235	13	*412494-BLK-130	8	55037330	13	*412494-WHT-130

* - SPECIAL ORDER: PLEASE QUOTE ITEM CODE UPON ORDERING THIS PRODUCT

412451 EVEREST PULL-ON HIGH-LEG SAFETY BOOTS WITH TPU SOLE



- Heavy-duty rigger style boot
- Ideal for building, manufacturing and the oil and gas industry
- Fully-lined with poly mesh
- 200J steel toe cap
- Anti-static
- Buffalo waxy water resistant leather
- Leather pull-loops
- EVA footbed with poly mesh cover
- Anti-static footbed
- PU injection anti-static midsole
- TPU anti-static outsole



Complies With:

- AS 2210.3:2019
- ASTM F2413
- EN ISO 20345



Size	Bishops Code	Size	Bishops Code	Size	Bishops Code
5	*412451-050	8	55037430	11	55037460
6	55037410	9	55037440	12	55037470
7	55037420	10	55037450	13	*412451-130

* - SPECIAL ORDER: PLEASE QUOTE ITEM CODE UPON ORDERING THIS PRODUCT

412450 AMAZON LACE-UP SAFETY SHOES WITH TPU SOLE



- Stylish and tough, this shoe allows you to move freely from office to worksite
- Fully-lined with poly mesh
- 200J steel toe cap
- Buffalo waxy water resistant leather
- PU foam padded collar
- Derby shoe
- EVA footbed with poly mesh cover
- Anti-static footbed
- PU injection anti-static midsole
- TPU anti-static outsole
- Colour: Black



Complies With:

- AS 2210.3:2019
- ASTM F2413
- EN ISO 20345



Size	Bishops Code	Size	Bishops Code	Size	Bishops Code
5	55036805	8	55036830	11	55036860
6	55036810	9	55036840	12	55036870
7	55036820	10	55036850	13	*412450-130

* - SPECIAL ORDER: PLEASE QUOTE ITEM CODE UPON ORDERING THIS PRODUCT

BAMBOO WORK SOCKS



- Super soft and comfortable to wear
- Naturally anti-fungal and anti-bacterial
- Hard wearing
- Highly absorbent
- Grey



Size	Bishops Code
5-7	55580010
7-10	55580020

INSECT SHIELD CREW SOCKS



IS-HCS1

- 76% combed cotton, 21% nylon, 3% Lycra
- Repel mosquitoes, ticks, ants, flies, chiggers and midges
- EPA-registered permethrin repellent built into the fabric
- Cushioned sole for comfort
- Small Insect Shield logo on each sock
- Khaki
- Two pairs per pack



Size	Bishops Code
9-11	55562377
10-13	55562378

BOOT LACES

- Available in two sizes
- Long length laces suit 8" Explorer safety boots
- Medium length laces suit all other safety boots
- Brown/Black



Size	Bishops Code
Medium - 6"	55039998
Long - 8"	55039999

WOMEN'S FIT SHOES

Workwear is traditionally designed for men, which meant in the past women in industry had no option but to wear smaller sizes of men's footwear. In reality, the anatomy of a female foot is quite different to that of a male foot and nowadays footwear is available that is designed specifically for female feet. This results in comfier footwear, better posture and healthier feet for women.



CONTACT BISHOPS FOR MORE INFORMATION ON WOMEN'S FOOTWEAR



03

WELDING & ABRASIVES

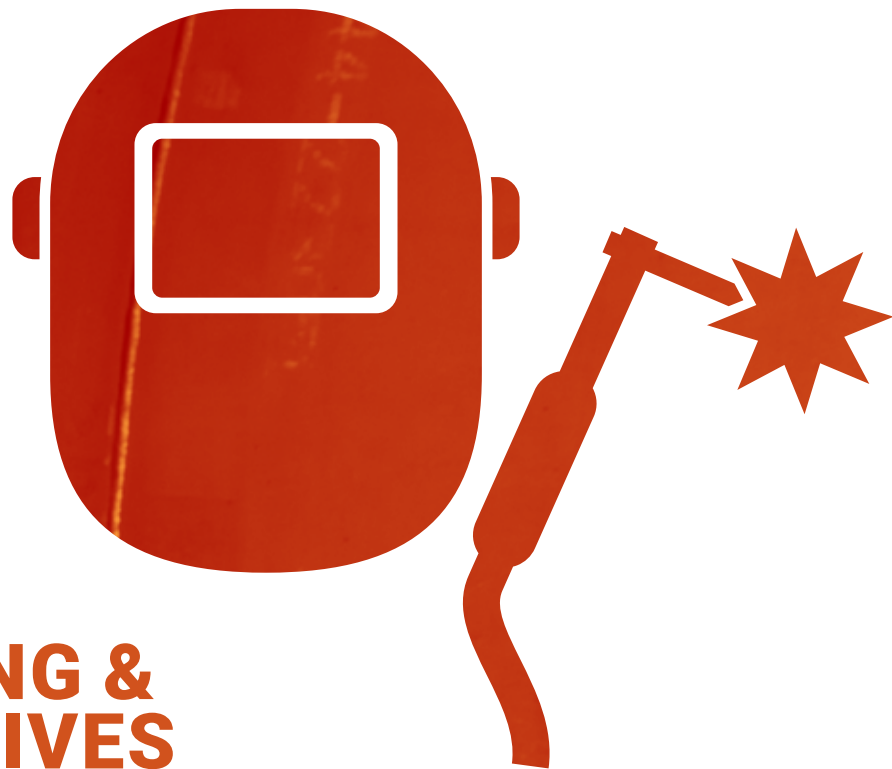

WELDING PROTECTION

Welding Helmets & Goggles.....	93
Welding Lenses.....	93
Welding Hoods & Protective Clothing.....	94–95
Welding Gloves.....	95
Welding Blankets, Screens & Curtains.....	96

WELDING MACHINES

MIG Welders.....	98
TIG, Multi-Process Welders.....	98–100
Arc Welders.....	100
Welder Inverters.....	100
Engine Driven Welders & Generators.....	101
Plasma Cutters.....	101

WELDING CONSUMABLES & ACCESSORIES

Welding Wire.....	102–103
Welding Guns & Torches.....	103
Electrodes & Brazing Rods.....	104–106
Electrode Heaters & Holders.....	106–107
Welding Leads, Clamp & Accessories.....	107–108
Arc Gouging.....	108

GAS WELDING, CUTTING & HEATING

Welding Gas Regulators & Flowmeters.....	108–109
Welding & Heating Tips.....	110–111
Blowpipes & Cutting Attachments.....	112
Flashback Arrestors.....	112
Cutting & Gouging Tips.....	113–114
Welding Hose & Fittings.....	114–115
Blowtorch.....	115
Welding & Cutting Kits.....	115–116

SOLDERING & BRAZING

Soldering Irons.....	116
Solder & Soldering Fluids.....	116–117

WELDING TOOLS & ACCESSORIES

Anti-Spatter, Flints & Tip Cleaners.....	118
Chipping Hammers & Welding Pliers.....	118
Measuring & Aligning Tools.....	118

CUTTING & ABRASIVES

Cut-Off Discs.....	121
Grinding Discs & Wheels.....	122–123
Mounted Points.....	123
Flap Wheels & Fibre Discs.....	123–124
Sanding Attachments.....	124–125
Flap Discs & Strip Discs.....	125
Wire Hand Brushes.....	126
Wire Wheel & Cup Brushes.....	126–127
Emery Cloth, Sandpaper & Sanding Belts.....	127–128
Wheel Dressers & Sanding Stones.....	128–129



SELECTING A WELDING HELMET

Passive or Auto-Darkening?

Passive, or traditional helmets, have a fixed shade lens, usually #10. When welding material is being positioned the helmet is worn above the head. Once the operator is ready to weld the helmet is pulled down to protect the face and eyes. This helmet type is economical and suited for novice or infrequent welders.

Auto-darkening helmets, as the name suggests, darken automatically once sensors on the helmet sense the arc start. This happens in a fraction of a second. This removes the need for it to be taken on and off for every weld, decreasing user fatigue or possible repetitive strain injury and better vision increases the quality of the weld. Auto-darkening helmets are ideal for everyday welders and industry professionals.

Auto-Darkening – Fixed or Variable Shade?

Auto-darkening helmets come in two varieties, fixed and variable shade.

Fixed shades auto-darken to a fixed #10 shade. This system combines economy with auto-darkening. These are suitable if your welding activities are repetitive with little differentiation.

Variable shade lenses typically adjust from shade #9 to shade #13 to allow the best possible view of the welding pool while still protecting your eyes. Premium models will allow adjustment of the sensitivity and delay controls to best suit your needs. This system is suitable if you engage in different welding processes (MIG, TIG, Stick), or vary in amperage frequently.

Sensor Sensitivity

Auto-darkening lenses use sensors to detect when the arc starts. For all helmets this happens in a fraction of a second, although if you spend the majority of your day welding, faster detection is beneficial and will reduce eye fatigue. Entry-level lenses are rated at approximately 1/3,600th of a second. Industrial grade helmets can be rated as high as 1/20,000th of a second. TIG sensor rating refers to the minimum amount of TIG amps required to activate the auto-darkening lens. If you weld under the minimum amp it is likely that the auto-darkening function will not work.

Viewing Area

Choosing a viewing area is a personal preference. Typically smaller viewing areas are most suited to light duties, whereas large screens are suited for industrial use.

Comfort & Fit

Be sure to try on your welding helmet, to ensure that it fits comfortably to your head. If you weld often, opt for a light-weight version that doesn't create pressure points on your head.



AUTO DARK WELDING HELMETS

- Impact resistant auto-darkening lens
- Made from high-impact polyamide nylon
- Solar powered with replaceable 3V lithium storage batteries
- Darkens in 1/25,000 of a second from when you begin welding
- Fitted with ratcheting headband and padded interior
- Provides full view of your welding work area as well as complete UV protection
- High/low light sensitivity adjustment
- Automatic power on/off with adjustable delay time
- Shades 8-13
- Lens size: 112 x 90.5 x 1.5mm
- AS/NZS 1338/ANSI Z87.1 approved



Design	Bishops Code
Black	55020180
Blue Flames	55020182
Blue	55020185
Black Stealth	55020189

PROLITE MATRIX 1.0 AUTO-DARKENING WELDING HELMET

- Quad 1 True Colour Lens with Blue Light Filter allows the operator to see truer colour at their work piece while reducing the operator's visual fatigue if concentrating on an arc all day
- Complies to Australian Standards
- 4 sensor auto-darkening filter lens
- Variable shade: 9-13
- High impact rating
- Low amperage TIG welding rating
- Magnification lens compatible
- Solar cells with battery back up
- 98 x 55mm viewing area
- Filter lens dimensions: 120 x 100 x 18mm
- Operating temperature: -5°C to 55°C
- AS/NZS 1337.1 & AS/NZS 1338.1



Item Code	Bishops Code
454344	55020187

FLIP UP ARC WELDING HELMET

- Flip-front lens makes it easy to inspect work
- Protects upper chest and throat from sparks and spatter during welding
- Comes with adjustable ratchet suspension
- The curved top of the mask provides extra protection to the head
- Lens: 114 x 50mm
- AS/NZS 1337:1992 approved



Description	Bishops Code
Flip Up Arc Welding Helmet	55020140
Helmet Suspension to Suit	55020195

HAND HELD WELDING MASK

- Made from moisture-proof polypropylene
- Tough, curved shell design with fixed front
- Provides full face protection from sparks
- Lens: 114 x 50mm



Item Code	Bishops Code
SE2735	55020130

OXY WELDING GOGGLES

- Soft, flexible vinyl frame
- Indirect ventilation
- 50mm round polycarbonate flip lens
- Can switch from welding to chipping for easy inspection
- Green shade 5
- Complies to standard CE EN175



Item Code	Bishops Code
	55015730

ROUND WELDING LENS

- CE EN166 approved
- Impact and spatter resistant polycarbonate lens
- Provides UV protection
- 50mm diameter

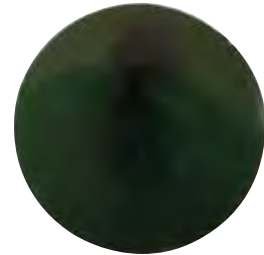

Colour	Bishops Code
Green	55015605
Clear	55015610

ARC WELDING LENSES

- Polycarbonate
- Impact and spatter resistant
- UV protection
- ANSI Z 87.1



Colour	Size	Bishops Code
Shade 9 Green	101.6 x 50mm	55015620
Shade 10 Green	101.6 x 50mm	55015630
Shade 11 Green	101.6 x 50mm	55015640
Shade 12 Green	101.6 x 50mm	55015650
Shade 13 Green	101.6 x 50mm	55015660
Shade 14 Green	101.6 x 50mm	55015665
Clear	114 x 50mm	55015670



HARMFUL AND VISIBLE LIGHT

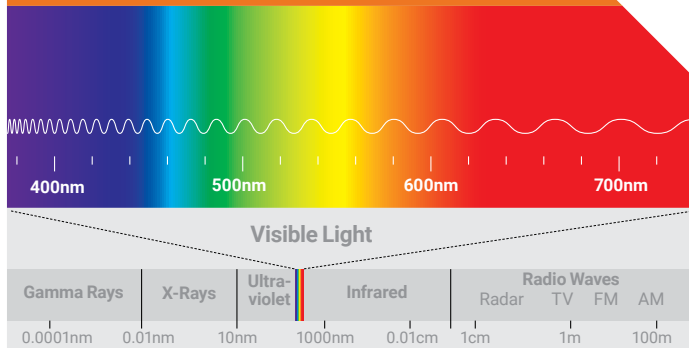

The welding arc emits three types of light – ultraviolet, visible light and infrared. Each element presents risks if the welder is not properly protected with quality equipment.

Ultraviolet Light

Exposure to ultraviolet light can cause of the cornea and conjunctiva, which is known as 'arc eye'. 'Arc eye' is caused by light damaging the outermost protective of the cornea. Gradually these damaged cells die, exposing highly sensitive nerves in the underlying cornea to the 'rough' inner eyelid. This causes severe pain, likened to sand in the eye.

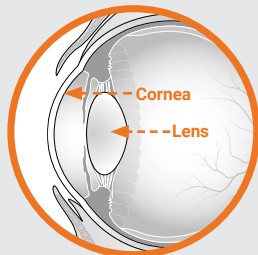

Visible Light

Intense wavelengths of visible light can irritate the cornea and the lens. Effects can differ depending on the duration, distance of the exposure and the individual's natural reflex action to close the eye. The irritation will not cause long-term effects, but may progressively reduce the ability to adapt to extreme light conditions.

Infrared Light

Infrared light is not visible, but is perceived by the body as heat. Continued exposure causes irreversible opacity of the lens leading to cataracts. While welding, any burning sensation on the skin surrounding the eyes may be caused by infrared light.



LEATHER WELDING HOOD

- Durable leather
- Includes adjustable neck straps and a flip front lens holder
- Suitable for arc welding jobs
- Protects chest, shoulders and head from sparks and splatter



Bishops Code
55020510

PYROMATE WELDERS HOOD

- Breathable flame resistant cotton
- Drawstring face closure for snug fit
- Side gussets for comfortable fit
- Maroon



Item Code	Bishops Code
PVHM	55020512

PROMAX WELDERS HOOD

- Lightweight and cool flame resistant cotton
- Hook and loop closure at front
- Drawstring face closure for snug fit
- Kevlar® heat resistant stitching to prevent seam failure
- Blue



Item Code	Bishops Code
WC-01795	55020514

LARGE CHROME LEATHER WELDERS JACKET

- Protects the wearer from sparks, spatter and radiant heat during welding
- Suitable for smelters, foundries and shipping, engineering and mining applications
- Snap button closure down the front, with a shirt-style collar
- Chrome Leather
- Length: 710mm



Bishops Code
55510010

CHROME LEATHER WELDING APRON

- Made from heavy duty fire retardant chrome split leather
- Excellent protection from welding splatter
- Adjustable heavy duty neck and waist straps with quick release buckles for easy fitting and removal
- Length: 1,066mm



Item Code	Bishops Code
WACL	55010040

WELDING KNEE PADS

- Chrome leather, foam filled
- Strap and buckle or Velcro® closure options



Description	Bishops Code
Leather Strap & Buckle Closure	55510060
Elastic/Velcro® Closure	55510050

WELDING GLOVES

- Full leather, reinforced double-palm
- Grey
- Length: 254mm
- One size
- Complies to standards EN388, EN420 and EN12477



Bishops Code
55040230

WELD SERIES GLOVES

- Premium quality blue cow split leather with gold Kevlar stitching to withstand high temperatures over extended periods of time
- Reinforced palm and thumb for added durability and protection
- Fully lined wear seams welted for extra strength
- Provides protection from welding spatter and dross heat
- Ideal for usage in welding and fabrication, metal castings, mining and construction
- Length: 406mm
- One size



Bishops Code
55040250

RED ARMOR WELDING GLOVES

- Full leather
- Reinforced thumb and double palm Kevlar
- Kevlar stitched in the optimum way to resist burning from sparks
- Suitable for all welding situations
- Red
- Length: 460mm



Bishops Code
55040240

BLUE BOMBERS WELDING GLOVES

- Cow split leather with Kevlar
- Fully lined with all wear seams welted for additional protection
- Provides protection from welding spatter and dross heat
- Blue
- Length: 406mm



Bishops Code
55040252

GET MORE AT BISHOPS ▶

FLAME RESISTANT CLOTHING

Page 76





WELDING BLANKETS & SCREENS

WELDING & ABRASIVES

LEATHER WELDING BLANKET

- Heavy duty cowhide leather
- Kevlar® stitching
- Designed to protect against grinding sparks and light to medium welding spatter
- Eyelets on each corner



Item Code	Bishops Code
8-LWB1818	55020525

WELDING SCREENS

- Safely surrounds and defines hazardous welding areas and protects co-workers from accidental welding flash
- Designed to absorb dangerous ultra-violet light during welding
- Suitable for safe observation of welding situations during safety checks
- All seams are welded for extra durability and strength
- Fitted with 200mm eyelets on all four sides for attaching to frame
- 1,300(w) x 1,800(h)mm
- Certified to AS 3957/NZ 5852:2006
- Frames not included



Colour	Luminance Factor	Bishops Code
Red	C3	55090210
Green	C5	55090215

WELDING SCREEN FRAME

- Light weight, portable, free standing, durable
- Includes 4 castors, 6 cable ties and 2 joiners
- Screens and curtains sold separately

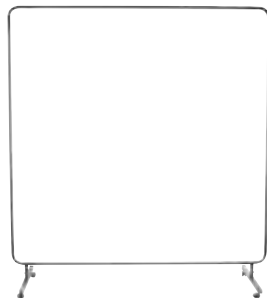

Size	Bishops Code
1.8 x 1.8m	55090295

WELDING CURTAINS

- Curtains include zip ties and rings, ready to install
- Frames sold separately
- Size: 1.8 x 1.8m



Item Code	Colour	Bishops Code
7-1818G	Green	55090230
7-1818R	Red	55090235

WELDING SCREENS



Creating A Safer Workplace

Welding is an inherently dangerous process. The instruments used to join two pieces of metal together can generate intense amounts of heat and light in doing so. If the welding process is not managed carefully, welders and those close by can be subjected to eye damage, burns, overexposure to UV light and even electric shock.

Just a glimpse of an arc torch in action can be enough to cause harmful flash burns. This is commonly known as **welder's flash or arc eye**. Symptoms include very mild to severe pain, light sensitivity, bloodshot or watery eyes and a sensation similar to sand in your eye.

Flash burn is like a sunburn to the eye and if left untreated, can result in serious infection. **If you think you have suffered a flash burn, stop work and seek urgent medical attention immediately.**

Welding curtains and screens exist to help prevent these dangers to welders and those nearby. Given the importance of good ventilation in a welding set-up, creating a more rigid enclosure can actually hinder air movement and result in a dangerous work space.

Use welding curtains, screens or strips to create a semipermeable enclosure that will help prevent those nearby from being affected by flashes of welding light, stray sparks and toxic fumes. However, welding curtains do not represent a total safety fix – the usual respiratory and fire safety precautions must always be taken to ensure a safe workplace.

Welding screens come with a variety of options. Mobile frames on castors are well suited to the welder on the move – simply adjust the screen to follow as you work along the weld.

Bishops can also supply custom solutions to suit your working environment. Contact us today to discuss your individual situation.

GET MORE AT BISHOPS



FIRE EXTINGUISHERS



Page 46

HOW TO SELECT A WELDING MACHINE

Unfortunately there is no one welding machine that is suitable for all welding applications. Each machine has its advantages and disadvantages.

Bishops is here to help you make an informed decision about your next welding machine. Got a question about one of the catalogued machines? Contact Bishops!

Welding Machine Power

Single or Three Phase Machine?

Welding machines come in single and three phase variations. Single phase machines require only one conductor, typical of domestic power points. A three phase machine requires three conductors, often only found at industrial work sites. Three conductors deliver significantly higher voltage, providing more 'grunt' to the machine and therefore making it more suitable for industrial use, as opposed to domestic or lighter applications.

Amps

The higher the current range the faster the weld, and the thicker the materials you will be able to work with.

Welding Processes:

Metal Inert Gas (MIG) welding is the process in which an electric arc forms between a consumable wire electrode and a metal work piece, which heats the metals causing them to melt and join. Shielding gas may feed through the welding gun along the electrode to shield the weld from any contaminants in the air. MIG welding is ideally used on steel, aluminium and other non-ferrous metals. Due to its versatility and speed the MIG weld process has become popular, however it tends to be more sensitive to external factors like wind, rain and dust.

Tungsten Inert Gas (TIG) welding is a welding process that uses a non-consumable tungsten electrode to produce a weld. The weld area is protected from oxidation by an inert shielding gas such as argon or helium. A TIG weld is commonly used to weld thin sections of stainless steel and non-ferrous metals such as aluminium, magnesium and copper alloys. This process creates stronger, higher quality welds, although it is more complex and difficult to master and significantly slower than alternative processes.

Arc welding uses electricity to create heat and bind metal with the aid of an electrode consumable. The weld region is protected from outside contaminants by a shielding gas. Arc welds are cost effective and versatile however they emit significant spatter and require cleaning upon completion.

Plasma cutting and welding uses ionised gases and electrodes that generate extremely hot plasma jets that are aimed at the welding area. The concentration of energy is good for narrow or deep welds, or increasing the speed of the welds.

Thermic Lancing is a process in which pure oxygen is supplied through a consumable steel pipe packed with steel wire. The resultant stream of liquid slag can rapidly cut through concrete and steel, making this an ideal process for demolition and emergency work.

Gas welding and cutting involves combining fuel gases with pure oxygen to increase the torch's heat to approximately 3,500°C, which is capable of melting steels. Also known as oxy/fuel welding, this technique was developed in 1903 making it one of the oldest processes. It is still used today in pipe and tube welding and cutting operations.

Soldering is used to form a permanent connection between electronic components. Two or more metals are joined together by melting and is therefore like a metallic 'glue' that holds parts together and forms a connection that allows for electrical current flow.





FAST FACT

Welding and cutting can release toxic fumes, including CO, CO₂, NO and NO₂.
Make sure you've got the right respiratory protection for the job!

WELDSKILL 250 MIG WELDER

- Excellent arc performance with solid and flux coated welding wires
- Suitable for use with CO₂, mixed gases or gasless operation
- Fan cooled with over temperature cut out
- Standard compliance
- Optional WeldSkill 4R Wire Feeder available separately
- Wire size range: 0.6–1.2mm (hard), 0.8–1.2mm (soft/cored)
- Supply voltage: 240V ±10% (50Hz)
- Generator requirement: 13kVA
- Current range: 50–270A
- Duty cycle (with upgraded supply lead and plug): 250A @ 20%
- Accepts 5kg and 15kg spools
- Dimensions: 1,020(d) x 470(w) x 1,050(h)mm
- Weight: 100kg
- 12 month conditional warranty

Includes:

- MIG torch
- Work lead
- Regulator/flowmeter
- Shielding gas hose assembly and adaptor
- Cylinder chain
- Spool adaptor
- Feed rolls
- Tips



CIGWELD



Item Code

W1004500

Bishops Code

71050230

WELDSKILL 350 MIG WELDER

- Excellent arc performance with solid and flux coated welding wires
- Suitable for use with CO₂, mixed gases or gasless operation
- Fan cooled with over-temperature cut out
- Standard compliance
- Optional WeldSkill 4R Wire Feeder available separately
- Wire size range: 0.6–1.2mm (hard), 0.8–1.2mm (soft), 0.8–1.6mm (cored)
- Supply voltage: 415V ±10% (50Hz), 3 phase
- Current range: 35–380A
- Duty cycle: 350A @ 30%
- Accepts 5kg and 15kg spools
- Dimensions: 1,050(h) x 470(w) x 1,020(d)mm
- Weight: 112kg
- 12 month conditional warranty

Includes:

- MIG torch
- Work lead
- Regulator/flowmeter
- Shielding gas hose assembly & adaptor
- Cylinder chain
- Spool adaptor
- Feed rolls
- Tips



CIGWELD



Item Code

W1004600

Bishops Code

71030250

EASYWELD 160 POWER PACK

CIGWELD

Includes:

- EasyWeld 160 QuickSet MIG
- MIG Consumables Kit – BZL-15 LH – Includes 8-Function MIG Pliers
- WeldSkill Essential Auto-Darkening Welding Helmet 9-13
- Heavy Duty Welding Gloves – Large
- WeldSkill Gasless Wire 0.9mm 4.5kg Handispool



Item Code

PPE160A21

Bishops Code

71050212

TRANSMIG 175I+ MIG/TIG/ARC WELDER

- Self-contained single phase welding inverter
- Multi-process capabilities – MIG, Stick and Lift TIG
- Built-in VRD (applicable in stick mode only)
- Digital voltage and amperage meters, integrated wire feed unit
- Wire size range: 0.6 0.9mm (hard), 0.8–1.0mm (soft), 0.8–1.2mm (cored)
- Supply voltage: 240V ±15%, 50/60Hz (15A plug)
- Current range: 10–185A (MIG), 10–175A (Stick), 10–175A (TIG)
- Duty cycle: 185A @ 20%, 23.3V (MIG)
175A @ 20%, 27.0V (Stick)
175A @ 25%, 17.0V (TIG)
- Accepts 1kg and 5kg spools
- Dimensions: 410(h) x 210(w) x 450(d)mm
- Weight: 14.6kg

Includes:

- MIG torch, regulator/flowmeter, feed rolls, contact tips, twistlock electrode holder and work clamp with leads, shielding gas hose assembly and bag with shoulder strap



Item Code

W1005185

Bishops Code

71030210

TIG WELDING TIPS

TIG requires a very clean surface to produce a clean arc and nice welds. Make sure you clean the work surface extremely well before you weld. For aluminium and stainless, use a dedicated stainless brush for each type of metal. The more time taken cleaning your work area before welding, the better the final results will be.

If you happen to touch your tungsten tip into the puddle, even for a split second, you have contaminated it and **you MUST regrind the tungsten electrode**. If you don't, the arc will start to wander badly and it will be difficult to keep a focused arc on the metal.

- TIG welding aluminium and steel – requires shielding gas
- TIG welding steel – is very easy, typically use DC polarity
- TIG welding aluminium – weld with AC polarity
- TIG welding stainless steel – welds almost like steel

TRANSMIG 255i MIG/TIG/STICK WELDER INVERTER



- 3-in-1 multi-process – MIG, Stick and TIG
- Duty cycle: 255A @ 40% (upgraded supply lead and plug)
- Input power 230/240V, 1Ph, 15A/25A
- Current range: 30–255A MIG
- Digital amperage and voltage meters
- 2 roll wire drive system
- Voltage Reduction Device (VRD), Stick mode only
- Optional spool gun available



Item Code	Bishops Code
W1005255	71030212

GET MORE AT BISHOPS ▶



WELDING CLAMPS
Page 204

BLUE VENOM XF186 MULTI PROCESS WELDING INVERTER



- MIG, Stick and Lift TIG DC.
- Synergic 3-in-1 welding inverter with MIG plate thickness selection
- Quick set, simple to set and weld
- Suitable for 100mm and 200mm diameter spools
- MIG Gasless and MIG Gas Shielded
- Blue LED meters for clear viewing
- Recommended MIG and TIG welding thickness range 0.6–10mm
- 10A plug
- 2 year conditional warranty



Item Code	Bishops Code
XF186	71050217

BLUE VENOM XF190 MIG/TIG/STICK WELDER



- Perfect solution for light fabrication, maintenance and repairs or for DIY around the home, workshop, worksite, or farm without compromising on quality, safety and performance!
- CIGWELD have introduced "Opti-Start", a feature that allows the user to customise their starting arc characteristics through Soft and Hard Start controls

Specifications:

- 10A 230V/240V
- MIG 185A @ 9% - Max Range 190A
- STICK 160A @ 10%
- TIG 190A @ 10%
- Power Source Weight 9.5kg
- 2 Year Warranty

Xtra Functions include:

- 2 x Roll All-Driven (top & bottom) Wire Drive system
- MIG Adjustable Wire Burnback & Inductance
- MIG Adjustable Soft & Hard Start (Opti-Start)
- MIG Wire Inch & Gas Purge Buttons
- MIG Anti de-spooling safety feature
- MIG Spool Gun Compatible
- STICK with Voltage Reduction Device (VRD)
- STICK Adjustable Hot Start & Arc Force
- STICK Anti-Stick
- TIG Foot Control and Dial Remote Torch Compatible

Includes:

- BlueVENOM XF190 Power Source
- CMGBZ15E3 MIG Gun 3m- Euro quick connector
- Work Clamp with 3m Lead
- Twist Lock Electrode Holder with 3m Lead
- 2 x Feed Rolls: 0.8/0.9mm Gasless, 0.8/0.9mm Solid Wires (Fitted).
- 2m Argon Gas Hose and Gas Regulator
- Nylon Inlet Guide for use on Soft Alloy Wires
- Operating Manual



Item Code	
W1400190	
SPECIAL ORDER: PLEASE QUOTE ITEM CODE UPON ORDERING THIS PRODUCT	

WELDSKILL 200HF TIG/ARC WELDER



- Single phase welding machine
- HF start (DC) TIG mode function
- Ultimate portability for light TIG fabrication and stainless steel work
- Supply voltage: 240V ±10%, 50/60Hz (15A plug)
- Current range: 10–200A (TIG), 10–180A (Stick)
- Duty cycle: 180A @ 20% (Stick), 200A @ 30% (TIG)
- User-friendly control panel
- Dimensions: 245(h) x 145(w) x 420(d)mm
- Weight: 8.2kg



Item Code	Bishops Code
W1008200	71050218



MULTI-PROCESS & ARC WELDING MACHINES & WELDER INVERTERS

WELDING & ABRASIVES

WELDKILL 205 AC/DC TIG/STICK PLANT WELDER



- Single phase AC/DC HF TIG, Stick
 - Input power: 230/240V, 1Ph, 15A
 - Current range: 10–205A (TIG), 10–160A (Stick)
 - Duty cycle: 205A @ 20% (HF TIG), 160A @ 20% (Stick)
 - AC/DC, HF TIG and Pulse on both AC and DC TIG
 - High frequency start
 - Adjustable pulse frequency, pulse width and wave balance
 - Supplied TIG torch with 8m lead and remote control
 - Digital meter
 - Suitable for 2.0, 2.5, 3.2 and 4.0mm stick electrodes
 - Compact and lightweight
 - 3 year limited warranty
- Complies With:
- AS 60974.1
 - IEC 60974-1



Item Code	Bishops Code
W1008205	71050200

ARC WELDERS

- Wheels allow convenient transport
- 3 phase
- Frequency: 50/60Hz
- Insulation Class H
- Yellow casing



71010120



71110130



71110140

Rated Input Capacity	Output Range	Voltage	Electrode Dia.	Duty Cycle	Dimensions	Weight	Bishops Code
6.2kVA	50–160A	240V	2.0–3.2mm	400A @ 35% 305A @ 60% 236A @ 100%	510(l) x 370(w) x 680(h)mm	48kg	71010120
12.6kVA	70–200A	240V	2.0–4.0mm	200A @ 35%	690(l) x 400(w) x 560(h)mm	58kg	71110130
30.5kVA	70–400A	380V	2.0–7.0mm	400A @ 60% 310A @ 100%	610(l) x 442(w) x 870(h)mm	112kg	71110140

AC/DC IN WELDING

For many welders **DC** is preferred for its ability to weld steel with a more stable arc, easier starts and less spatter. DC has either a positive or negative polarity. Positive polarity provides high penetration into steel, whereas negative results in less penetration. **AC** polarity flicks between negative and positive polarity.

The default for most welders is DC. However, aluminium is welded primarily with AC, as the alternating polarity creates a cleaning action that results in a smoother, higher quality weld.

WELDKILL MICROARC 140 WELDER INVERTER



- Extremely neat and compact welding inverter
 - Suitable for DIY and handyman work
 - Input power: 230/240V, 1Ph, 10A
 - Current range: 10–140A (Stick and Lift TIG)
 - Duty cycle: 140A @ 15% (Stick) and 140A @ 20% (Lift TIG)
 - Dimensions: 100(w) x 185(h)mm
 - Weight: 3kg
- Includes:
- 3m twist lock electrode holder
 - Work lead



Item Code	Bishops Code
W1008162	71050208

WELDKILL 180 INVERTER



- Compact and lightweight single phase welding machine
 - User friendly control panel
 - Ideal for tradesmen, farmers and maintenance workers
 - Supply voltage: 240V ±10%, 50/60Hz (15A plug)
 - Current range: 10–180A
 - Duty cycle: 180A @ 20% (Stick) and 180A @ 40% (TIG)
 - Dimensions: 220(h) x 130(w) x 340(d)mm
- Includes:
- 4m electrode holder
 - Work leads
 - Case with handle and carry strap



Item Code	Bishops Code
W1008180	71050214

MOBILE DIESEL ENGINE DRIVEN WELDERS

- DAS, auto engine protection shutdown system with warning lights in case of battery charger failure, high coolant temperature, low fuel level, low oil pressure
- 12V built-in battery with electric start
- Voltmeter
- Fuel level gauge
- Frequency: 50Hz
- Earth leakage circuit breaker (ELCB) (except 71080080)
- Engine hourmeter (except 71080020)
- Remote control socket (except 71080020)
- Central lifting eye (except 71080020)

Other Features for 71080020:

- Automatic idle device when no load is connected
- Arc force control switch

Other Features for 71080045:

- Emergency stop button
- Low-high amps switch for a more accurate arc control selection (30A ÷ 200A/30A ÷ 400A)
- Weld voltmeter and ammeter
- Arc force control with changeover switch basic/cellulose welding rods
- Lift start TIG facility
- CC/CV control for MIG welding
- Forklift pockets

Other Features for 71080080:

- Arc force control with changeover switch basic/cellulose welding rods
- Central lifting eye
- Forklift pockets



71080020

Description	Welding Processes	Duty Cycle	Output Range	Engine	Power	Speed	Noise Level	Dimensions	Weight	Bishops Code
1 x 16A, 400V – 50Hz Three-Phase EEC Socket 1 x 16A, 230V – 50Hz Single-Phase EEC Socket Protected By Circuit Breaker 1 x 48V – 50Hz Single-Phase Outlet (Safety Low Voltage)	SMAW (Stick)	170A @ 35% 140A @ 60%	40–170A	Yanmar L100 AE	10hp	3,000rpm	74dB	920(l) x 460(w) x 570(h)mm	148kg	71080020
1 x 32A, 400V – 50Hz Three-Phase EEC Socket 2 x 32A, 230V – 50Hz Single-Phase EEC Sockets Protected by Circuit Breakers 1 x 48V – 50Hz Single-Phase Outlet (Safety Low Voltage)	SMAW (Stick)/TIG/ CAG	500A @ 60% 400A @ 100%	30–500A	Deutz F3L912	38hp	1,500rpm	78dB	590(l) x 800(w) x 1,150(h)mm	920kg	71080080

PRACTICE SAFE WELDING

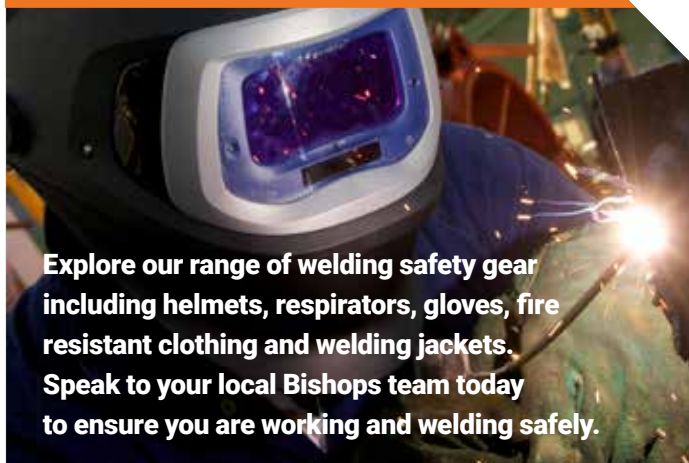

Explore our range of welding safety gear including helmets, respirators, gloves, fire resistant clothing and welding jackets. Speak to your local Bishops team today to ensure you are working and welding safely.

5KW DIESEL WELDER GENERATOR

- Advanced air-cooled diesel engine, electric start
- Single phase, four stroke engine
- Large fuel tank
- Stable welding current and waveform
- Dual function
- AC output
- Frequency: 60Hz
- Engine: KD186FAE
- Power: 8.6hp
- Output range: 50–180A, 2.2kVA
- Voltage: 240V
- Duty cycle: 180A @ 60%
- Noise level: 74–79dB
- 775(l) x 485(w) x 580(h)mm
- Weight: 154kg



Item Code	Bishops Code
5GF-MEW	74090050

CUTSKILL PLASMA CUTTERS



- Single phase
- Input air: 460kPa, 110lpm
- Comes with CutSkill 60A plasma torch, work cable and clamp, air filter wrench, 1/4" Nitto air line connector, shoulder strap and operating manual

Cutskill 35:

- Cutting capacity: 12–16mm (mild steel), 10mm (stainless), 8mm (aluminium)
- Supply plug: 10A

Cutskill 45:

- Cutting capacity: 16–24mm (mild steel), 12mm (stainless), 10mm (aluminium)
- Supply plug: 15A

CutSkill 60:

- Cutting capacity: 20–28mm (mild steel), 14mm (stainless), 12mm (aluminium)
- Supply plug: 15A
- Upgrade to 4mm² lead and 20A plug to achieve 60A @ 30% Duty Cycle



1-1601-40

Item Code	Description	Duty Cycle	Size	Weight	Bishops Code
1-1601-30	Cutskill 35	35A @ 35%	415(l) x 176(w) x 324(h)mm	11.8kg	71040152
1-1601-40	Cutskill 45	45A @ 35%	415(l) x 176(w) x 324(h)mm	11.8kg	71040154
1-1601-60	CutSkill 60	60A @ 20%	347(l) x 176(w) x 324(h)mm	13.2kg	71040155

ESAB CUTMASTER+ PLASMA CUTTERS



Cutmaster 40+

- Genuine Cutting & Piercing: 12mm
- Regular Hand Cutting: 16mm
- Max Severance Cut: 25mm
- Input Voltage: 230VAC +/- 10%, 50/60Hz, 1ph, 15A plug

Cutmaster 50+

- Genuine Cutting & Piercing: 16mm
- Regular Hand Cutting: 25mm
- Max Severance Cut: 32mm
- Input Voltage: 400AC +/- 15%, 50/60Hz, 3ph

Cutmaster 70+

- Genuine Cutting & Piercing: 20mm
- Regular Hand Cutting: 30mm
- Max Severance Cut: 38mm
- Input Voltage: 400AC +/- 15%, 50/60Hz, 3ph

Includes:

- Cutmaster+ Power Source
- SL60 75" torch and 5m lead
- 3m Work lead with ground clamp
- Consumables kit
- Air fitting 1/4" PT Nitto type
- Quick Start Guide
- Operating Manual



Cutmaster 50+

Item Code	Description	Power	Dimensions	Weight	Bishops Code
0559141006	Cutmaster 40+	40A @ 40%	465(l) x 200(w) x 315(h)mm	11.5kg	71040153
0559150006	Cutmaster 50+	50A @ 60%	465(l) x 200(w) x 315(h)mm	16kg	*0559150006
0559170006	Cutmaster 70+	70A @ 50%	465(l) x 200(w) x 315(h)mm	16kg	*0559170006

* – SPECIAL ORDER: PLEASE QUOTE ITEM CODE UPON ORDERING THIS PRODUCT



WELDING WIRES

FLUX CORED WELDING WIRE

• Sold in 15kg spools

Verti-Cor Ultra:

- General purpose, versatile rutile type flux cored wire
- Exclusively for CO₂ shielding gas
- All positional capabilities
- Low spatter and fume levels

Verti-Cor 3XP:

- Micro alloyed rutile type flux cored wire
- Versatile all positional capabilities

Supre-Cor 5:

- Second generation fully basic flux cored wire
- Improved low temperature impact toughness to -50°C

Verti-Cor 3XP H4:

- Versatile, copper coated seamless wire
- All positional capabilities
- Very low H4 class hydrogen levels
- Suits wide range of mild to medium strength steels

Verti-Cor 81 Ni1

- Higher strength, low alloy rutile type flux cored wire
- Suits argon + 20-25% CO₂ or equivalent shielding gas
- Versatile all positional capabilities



Item Code	Diameter	Bishops Code
VERTI-COR ULTRA		
720900	1.2mm	71870512
720902	1.6mm	71870516
VERTI-COR 3XP		
720919	1.2mm	71870508
720921	1.6mm	71870510
SUPRE-COR 5		
720982	1.2mm	71870315
VERTI-COR 3XP H4		
722919	1.2mm	71870507
VERTI-COR 81 NI1		
720391	1.6mm	71870518

CORESHIELD 8 FLUX CORED MILD STEEL WELDING WIRE



- Self shielded flux cored wire
- Designed to weld critical structural applications while maintaining excellent arc characteristics and high welder appeal using DCEN polarity
- All positional
- Diameter: 1.6mm
- 11.34kg spool



Item Code	Bishops Code
0242206399	71870504

WELDSKILL GASLESS WELDING WIRE

- Self-shielded flux cored wire
- For single and multiple pass applications
- Versatile, all positional capabilities
- Excellent tolerance to joint misalignment or poor joint fit-up
- Smooth rippled fillets with good edge wetting
- Ideal for welding thin section mild and galvanised steels
- 4.5kg handi spool



Item Code	Diameter	Bishops Code
WG4509	0.9mm	71870204
WG4512	1.2mm	*WG4512

* - SPECIAL ORDER: PLEASE QUOTE ITEM CODE UPON ORDERING THIS PRODUCT

AUTOCRAFT LW1-6 GAS SHIELDED WELDING WIRE



- A higher manganese/silicon wire for GMAW welding of mild and low alloy steels
- Designed for use with CO₂ and argon based shielding gases
- Large range of other sizes available
- 15kg spool

Classifications:

- AWS/ASME-SFA A5.18: ER70S-6



Item Code	Diameter	Bishops Code
720090	0.9mm	71870210
720096	1.2mm	71870214

AUTOCRAFT AL5356 GAS SHIELDED ALUMINIUM WELDING WIRE



- For the GMAW welding of wrought and cast aluminium alloys containing magnesium
- Patented lubrication process for superior wire feed ability



Item Code	Diameter	Spool Weight	Bishops Code
722226	0.9mm	7kg	71870409
723224	1.0mm	2kg	71870410
722224	1.0mm	7kg	71870411
722227	1.2mm	7kg	71870412

WELDSKILL SOLID MIG WELDING WIRE



- Copper coated steel wire for GMA welding
- Suitable for the positional Gas Metal Arc Welding (GMAW) of mild and low alloy steels used in general fabrication structural work

Classification:

- AS/NZS 2717.1: ES6-GC/M-W503AH
- AWS/ASME-SFA A5.18: ER70S-6



Item Code	Diameter	Bishops Code
WS5008	0.8mm	71870310
WS5009	0.9mm	*WS5009

* - SPECIAL ORDER: PLEASE QUOTE ITEM CODE UPON ORDERING THIS PRODUCT

COMWELD TIG MILD STEEL FILLER WIRE



- Uncoated filler rod suitable for oxy-acetylene fillet and butt welding of carbon steel and wrought iron, gas or TIG welding
- 5kg



Item Code	Diameter	Length	Bishops Code
321334	1.6mm	1m	71880116
321337	2.4mm	75cm	71880125

COMWELD TIG WELDING WIRE

Comweld 316L:

- Gold colour coded for easy identification
- High quality low carbon rod for gas and TIG welding

Comweld LW1-6:

- Copper coated low carbon steel rod for TIG and oxy-acetylene welding

Comweld AL5356:

- Premium quality aluminium-nominal 5% magnesium alloy rod
- For gas or TIG welding

Classifications:

- AS/NZS 14341: B G 55A 3 C1/M21/M24 S4M31
- B G 57A 3 C1/M21/M24 S4M31
- AWS/ASME-SFA A5.28: ER80S-D2 / ER90S-D2

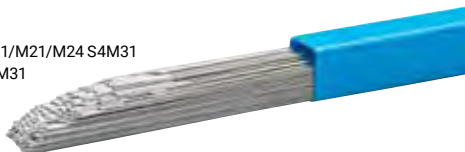

Item Code	Diameter	Pack Size	Bishops Code
COMWELD 316L			
321400	1.6mm	5kg	71875010
321401	2.4mm	5kg	71875012
COMWELD LW1-6			
321417	1.6mm	5kg	71875016
321418	2.4mm	5kg	71875018
COMWELD AL5356			
321640	1.6mm	2.5kg	71870620
321641	2.4mm	2.5kg	71870625

TIG TORCH 26F WITH FLEX HEAD

- 4m lead
- Trigger switch and remote control
- 50mm² dinse plug
- Rated for 200A DC @ 30% and 300A DC @ 14%



Item Code	Bishops Code
W4014604	71280425

TWECO STYLE MIG WELDING GUN

- Heavy duty design
- High impact resistant handle and components
- Large range of consumables available
- Metal jacketed conductor tube
- Oval handle shape reduces operator fatigue
- Heat resistant
- Tweco No. 5 – 3.6m



Item Code	Bishops Code
717211	71260442

CONTACT TIPS

- Suit TWE1 mini gun
- 10 pack



Item Code	Size	Bishops Code
TWT1109	0.9mm	71260090
TWT1110	1.0mm	71260091
TWT1112	1.2mm	71260092

HOW TO PREP A SURFACE FOR WELDING

A great weld starts with preparation. A poorly prepared metal surface can cause defects in the weld that make it weak. We've got all the tools you need for a strong weld – Find them at Bishops!

Find grinders in our **Power, Pneumatic & Engine Powered Tools** section.



Electric Grinders
Page 138

Pneumatic Grinders
Page 146

How to Prepare an Aluminium TIG Weld

Aluminium needs to be approached differently than steel prior to welding.

Use a stainless steel abrasive such as a stainless wire brush, stainless steel wool or an iron-free grinding disc to clean the surface thoroughly. Make sure this abrasive has not been used on any other metal to avoid contamination of the aluminium.

The more effort you put into your preparation, the cleaner and stronger the end result can be.

Bishops can supply specialist TIG cleaning products to get your welds shiny and clean. Call us for more information today!

GET MORE AT BISHOPS



SURFACE PREPARATION PRODUCTS

From Page 119



ELECTRODES

COBALARC WELDING ELECTRODES



Cobalarc 650:

- Basic electrode for the hard surfacing of steel components subjected to wet or dry hard particle abrasion and low to moderate impact loading

Cobalarc 750:

- Smooth running, rutile type electrode specifically designed for AC hard surfacing applications

- Resistant to hard particle abrasion

Cobalarc CR70:

- Highly alloyed manual arc electrode
- Ideal for coarse abrasion and low to moderate impact loading



Item Code	Diameter	Pack Size	Bishops Code
COBALARC 650			
611463N	3.2mm	5.0kg	71860014
611464N	4.0mm	5.0kg	71860018
COBALARC 750			
611473	3.2mm	5.0kg	71860022
611474	4.0mm	5.0kg	71860024
COBALARC CR70			
613494	4.0mm	5.0kg	71860030

WELDING ROD – E6013

- High speed
- A fill-freeze mild steel electrode
- Suitable for AC or DC output welding



Diameter	Pack	Bishops Code
2.5mm	2.5kg	71800026
2.5mm	5kg	71810026
3.2mm	5kg	71810032
4.0mm	5kg	71810040

STAINLESS ELECTRODES



Satinchrome 309Mo – 17:

- Smooth running rutile type stainless steel electrode
- All position (except vertical down) fillet and butt welding of 24Cr/13Ni type stainless steel

Satinchrome 316L – 17:

- Smooth running rutile type stainless steel electrode
- All position (except vertical down) fillet and butt welding of 19Cr/10Ni type stainless steel

Weldall:

- Highly alloyed stainless steel
- Deposits a strong and ductile duplex Austenitic-ferrite weld
- Extremely resistant to cracking
- Suitable for all types of steel



Item Code	Diameter	Pack Size	Bishops Code
SATINCHROME 309MO – 17			
611692N	2.5mm	1.7kg	71830458
611693N	3.2mm	1.9kg	71830460
611693N	4.0mm	4.4kg	71830462
SATINCHROME 316L – 17			
611661N	2.0mm	1.6kg	71830450
611662N	2.5mm	1.7kg	71830452
611663N	3.2mm	2.0kg	71830454
611664N	4.0mm	4.3kg	71830456
WELDALL			
610702	2.5mm	1.0kg	71830005
611702N	2.5mm	1.6kg	71830012
611703N	3.2mm	1.8kg	71830014

FERROUS ELECTRODES



Satincraft 13:

- General purpose, rutile type electrode
- All positional capabilities
- Smooth mitre fillet welds with low spatter
- Blue flux

ESAB SPEZIAL OK53.16:

- Double coated electrode combining the running characteristics of a rutile electrode with the mechanical properties of a basic electrode
- Small pack sizes reduce waste and cost
- Vacuum sealed to reduce moisture absorption and electrode damage
- Smooth running on AC and DC with low spatter

Ferrocrafft 21:

- Versatile rutile type, medium powder iron electrode
- All positional capabilities
- Easy striking – hot or cold
- Ideal for vertical down fillet welding

Ferrocrafft 22:

- Rutile type, high powder iron electrode
- High productivity fillet and butt welding in all downhand positions
- Self-releasing slag

Ferrocrafft 61:

- Basic coated, hydrogen controlled E4818/E7018 type electrode
- Superb AC/DC operator appeal
- Excellent out of position welding
- Reliable impact properties to -30°C

Smoothcraft E6013

- General purpose, rutile-Ilmenite type electrode
- Outstanding operator appeal, versatile – all positional capabilities, smooth mitre fillet welds with low spatter



Item Code	Diameter	Pack Size	Bishops Code
SATINCRAFT 13			
611182	2.5mm	5.0kg	71810070
611183	3.2mm	5.0kg	71810072
611184	4.0mm	5.0kg	71810074
ESAB SPEZIAL OK53.16			
53162534G1	2.5mm	1.8kg	*53162534G1
53163234G0	3.2mm	1.6kg	71810232
53164044G0	4.0mm	2.2kg	*53164044G0
FERROCRAFT 21			
611242	2.5mm	5.0kg	71810220
611243	3.2mm	5.0kg	71810222
611244	4.0mm	5.0kg	71810224
611245	5.0mm	5.0kg	71810226
FERROCRAFT 22			
611253N	3.2mm	5.8kg	71820344
611254N	4.0mm	5.3kg	71820346
FERROCRAFT 61			
611342	2.5mm	5.0kg	71810240
611343	3.2mm	5.0kg	71810242
611344	4.0mm	5.0kg	71810244
SMOOTHCRAFT E6013			
611042	2.5mm	5.0kg	71810060
611043	3.2mm	5.0kg	71810063
611044	4.0mm	5.0kg	71810064

* – SPECIAL ORDER: PLEASE QUOTE ITEM CODE UPON ORDERING THIS PRODUCT

SHAPING TUNGSTEN ELECTRODES



Rounded or tapered ball end electrodes are typically used for welding non-ferrous metals like aluminium and magnesium



Pointed tips are typically used for welding ferrous metals like steel

10 TIPS TO A SAFER WELDING WORKPLACE



1

Read the manual

Every piece of equipment is different. As such, many manufacturers provide an operating manual with their equipment to help you remain safe in the workplace. Make sure to become familiar with the contents of the manual and remember, if it gets lost, check online or contact the manufacturer.

2

Cover up

Ensure that none of your skin is exposed during the job. The rays and sparks that emit from the welder can be harmful to your skin. To help prevent any damage, make sure to always zip up, button up and cover up!

3

Dress to impress

Even the smallest jobs require the proper gear, this includes a helmet, gloves and the right clothing. Find flame resistant clothing in this catalogue from page 75 and welding protective clothing from page 92. Many modern clothing options are lightweight and offer fire resistance, so there's no excuses!

4

Wear the right footwear

Always wear enclosed shoes during the job. Hightop boots offer the best protection. Always make sure that your pants go over your boots to prevent sparks getting inside your footwear.

5

Air is a gift

Make sure that the workplace is well ventilated. Many fumes that are emitted during the welding process can be very hazardous to your health. It is recommended to use an exhaust hood to remove all of the fumes from the area. In certain welding applications you will need a respirator, purified or supplied fresh air to protect yourself.

6

Don't look into the light

Whilst arc rays are harmful to your skin, they are even more harmful to your eyes. Exposure to welding arcs may cause an arc flash which can cause burns that may not be noticeable straight away. Make sure to use a helmet with proper lens shading for the job. Welding screens should also be installed to protect those around you from exposure.

7

Auto-darkening helmets

Many modern day helmets have auto-darkening features. This allows the lens to darken in a fraction of a second after exposure to welding rays. Newer helmets also have different modes, allowing for the same helmet to be used for different jobs. Be cautious in cold weather as auto-darkening reaction times may be delayed.

8

No stress, no mess

Use of traditional fixed shade helmets can often lead to fatigue from snapping your neck to lower the lens. Auto-darkening helmets remove the need to do so and can reduce the neck fatigue that you experience.

9

Keep it clear

Working in a cluttered workplace can be dangerous and provides many tripping hazards. Keep your workplace clear of unnecessary clutter and cables, only the tools and equipment that you are using should be around.

10

A safe workplace is a happy one

Safety should be embedded into the daily habits of your workplace. Most safe workplaces use a combination of incentives and punishments to help encourage the use of safety gear. Find the perfect balance that works in your workplace.

www.bishopbros.com.pg



ELECTRODES, HEATERS & HOLDERS

CASTCRAFT 100 ELECTRODES

- Maintenance welding of cast irons
- Lime gluorspar/graphite coating
- Soft, ductile nickel deposit
- Easy starting and stable running on portable 240V welding machines
- Ideal for repair and maintenance jobs
- Smoother weld deposit surface finish
- Classification: AWS/ASME-SFA A5.15: ENI-CI



Item Code	Diameter	Pack Size	Bishops Code
611732N	2.5mm	2.0kg	71840313
611733N	3.2mm	2.0kg	71840314
611734N	4.0mm	2.0kg	71840315

COPPER ALLOY WELDING RODS

- Equivalent standards AWS RBCuZn-C
- Chemical composition: Sn0.9, Si0.1, Fe 0.8
- Low fuming bronze to gas weld or carbon arc weld bronze copper
- Can braze weld copper, steel or cast iron as well
- Melts at approximately 860°C
- For modern, high-speed production and general repair



Description	Description	Size	Pack Size	Bishops Code
322021	Flux Coated	3.0mm	2.5kg	71865050

COMWELD COMCOAT BRAZING RODS



- Self-fluxing rods suitable for a wide range of braze welding applications
- Comcoat C Manganese Bronze Filler Rod – Suitable for braze welding of steel, cast and malleable irons
- Comcoat T Tobin Bronze Filler Rod – Suitable for braze welding of certain brass and bronze surfaces, and low-strength brazing of steels. Not suitable for cast irons
- Comcoat N Nickel Bronze Filler Rod – Suitable for high strength braze welding of steels, cast or malleable irons, and fusion welding of copper-based alloys
- AS/NZS 1167.1, AS/NZS 1167.2
- AWS/ASME-SFA A5.8/A5.7



Item Code	Size	Flux Colour	Approx. Melting Point	Weight	Bishops Code
COMCOAT C					
321191	2.4mm	Blue	890°C	2.5kg Pack	71880324
322206	2.4mm	Blue	890°C	5 Rod Blister Pack	71880330
COMCOAT T					
322207	2.4mm	White	900°C	5 Rod Blister Pack	71880335
COMCOAT N					
322208	2.4mm	Pink	910°C	3 Rod Blister Pack	71880340

ELECTRODE HEATER

- Electrode stabilising in-shop oven
- Modular design with recessed controls for protection
- Removable shelves
- Compact and fully insulated
- Features nesting feet and sockets for easy stacking
- Fitted with thermostat control and pilot light
- Capacity: 159kg
- Electrode size: Up to 457mm long
- Voltage: 115V or 220V, AC only
- Temperature range: 37.8°C–287.8°C
- Outer dimensions: 559 x 559 x 622mm
- Inner dimensions: 356 x 405 x 482mm
- Weight: 50kg



Item Code	Bishops Code
GUL350220	71255020

ELECTRODE HEATER

- Portable electrode oven
- Fitted with thermostat control and a pilot light
- Not suitable for stacking
- Oven opens from the top with a lift-up lid
- Line cord: 2,428mm
- Element: 125W
- Capacity: 9kg
- Electrode size: Up to 457mm long
- Voltage: 115V or 220V, AC only
- Temperature range: 38°C–148°C
- Outer dimensions: 178(dia.) x 585(h)mm
- Inner dimensions: 76(dia.) x 483(h)mm
- Weight: 75kg



Item Code	Bishops Code
6-EC7510	71255009

TWIST-LOCK ELECTRODE HOLDERS



- Heavy duty twist-lock welding electrode holders



Item Code	Duty Cycle	Electrode Capacity	Bishops Code
646165	250A	5mm	71240690
CEH400TL	400A	5mm	71240695
646343	600A	8mm	71240699

GET MORE AT BISHOPS



WELDING GLOVES

Page 95

TWIST-LOCK ELECTRODE HOLDERS

- Twist type



Description	Bishops Code	Description	Bishops Code
400A	71240600	600A	71240650
500A	71240640	800A	71240680

TONG STYLE ELECTRODE HOLDERS

- Clamp type



Description	Bishops Code
300A	71240100
500A	71240300
600A	71240500

WELDING LEAD SETS

- 400A
- Comes with 50mm dinse



Item Code	Length	Bishops Code
646757	5m	71230917
646325	8m	71230919

WELDING LEADS

- 300A
- Length: 5m



Description	Bishops Code
Lead With Electrode Holder & Connector	71230900
Lead With Earth Clamp & Connector	71230910

WELDING WORK CLAMPS

- Heavy duty spring loaded jaw style clamps
- Copper jaws with copper braided shunt
- Zinc plate steel construction



Item Code	Duty Cycle	Jaw Opening	Suits Cable	Bishops Code
646348	200A @ 60%	63(d) x 38(h)mm	25mm ²	71235270
646349	400A @ 60%	76(d) x 63(h)mm	70mm ²	71235275
646350	600A @ 60%	76(d) x 76(h)mm	95mm ²	71235280

WELDING EARTH CLAMPS

- Spring type clamps



Description	Bishops Code
300A – Large	71235020
300A – Small	71235040
500A – Large	71235220
500A – Small	71235240
600A	71235260

G-STYLE WELDING EARTH CLAMP



- All brass construction with steel fixing screw
- Compact and durable clamp
- Suits 95mm² welding cable
- Duty cycle: 500A @ 60%
- Jaw opening: 40(d) x 42(h)mm



Item Code	Bishops Code
646351	71235300

WELDING CABLE

- Finely-stranded copper conductor
- Operating temperature: -25°C–+90°C
- 100V
- Sold per metre
- AS/NZS 1125, AS/NZS 1995 and AS/NZS 5000.1 approved
- Flame retardant to standard AS/NZS 1660.5.6



Item Code	Size	Max. Current	Bishops Code
7901220	16mm ²	225A @ 30%	71230016
7901221	25mm ²	300A @ 30%	71230025
7901222	35mm ²	375A @ 30%	71230035
7901223	50mm ²	475A @ 30%	71230050
7901273	70mm ²	590A @ 30%	71230070
7901225	95mm ²	715A @ 30%	71230095



ARC GOUGING & PRESSURE REGULATORS

WELDING & ABRASIVES

CABLE CONNECTORS

- MechConnector Style
- Compatible with Lincoln, Cigweld and more
- Joiner male and female set
- Suit cable size: ≤70mm²



Item Code	Bishops Code
WC-01499	71230250

DINSE SOCKETS & PLUGS

Sockets

- Allows maximum current carrying capacity, minimising wear and increasing cost-effectiveness
- 50mm

Plugs

- Designed to fit welding cables to welding machines
- Male connection
- 50mm



71230555

Item Code	Description	Bishops Code
704460	Socket	71230555
704461	Plug	71230550

ARC GOUGING TORCH

- For gouging, cutting, bevelling, piercing and flushing metal
- Uses the Air Carbon-Arc cutting process to remove any kind of metal
- 2 flair with 2.1m swivel cable
- Fitted with rubber guard over connector piece
- Max. DC current: 600A
- Max. AC current: 450A



Item Code	Bishops Code
K3	71480180

POINTED DC GOUGING CARBONS

- Fast, clean, smooth, hassle free gouging
- Used to remove metal from a wide range of common ferrous and non-ferrous metals
- Designed for DC operation
- Superior arc stability
- Air pressure: 550–690kPa
- Length: 305mm
- 50 per pack



Item Code	Diameter	Current Range	Bishops Code
22043003	6.5mm	300–400A	71890060
22053003	8.0mm	350–450A	71890080
22063003	9.5mm	450–600A	71890090

CUTSKILL REGULATORS



- Excellent performance
 - For use with most light to medium cutting and welding applications
 - Based on CIGWELD's COMET™ design
 - Strong, robust construction combined with renowned CIGWELD quality
 - Fail safe against over pressure and diaphragm protected against flashback
 - Factory set to deliver maximum pressure
 - Captive control knob prevents loss and tampering
 - Colour coded for easy identification
 - Connection outlet: 5/8"–18 UNF
- Complies With:
- AS4267



210103



210222



210223

Item Code	Rated Air Flow	Gauge Range Inlet	Gauge Range Outlet	Connection Inlet	Outlet	Bishops Code
LPG – MAX. OUTLET PRESSURE: 400KPA						
201003	230L/min	–	600kPa	AS2473 Type 21 (0.880" – 14 NGO LH Ext)	LH Ext	71460100
OXYGEN – MAX. OUTLET PRESSURE: 800KPA						
210222	310L/min	30,000kPa	1,600kPa	AS2473 Type 10 (5/8" BSP RH Ext)	RH Ext	71460041
ACETYLENE – MAX. OUTLET PRESSURE: 150KPA						
210223	150L/min	4,000kPa	300kPa	AS2473 Type 20 (5/8" BSP LH Ext)	LH Ext	71460021

REGULATORS



- Brass valve stems
- Australian standard fittings



71460020



71460090

Description	Max. Inlet Pressure	Includes	Bishops Code
Acetylene Regulator	2,000kPa @ 15°C	2 x Dial Indicators	71460020
Oxygen Regulator	20,000kPa @ 15°C	2 x Dial Indicators	71460040
LPG/Propane Regulator	400kPa @ 15°C	1 x Safety Gauge Dial	71460090

OXYGEN PRESSURE GAUGES

- Low and high pressure options



71468000



71468100

Description	Max. Pressure	Bishops Code
Low Pressure	1,000kPa	71468000
Low Pressure	1,400kPa	71468040
High Pressure	28,000kPa	71468100

ACETYLENE PRESSURE GAUGES

- Low and high pressure options



71468540

Description	Max. Pressure	Bishops Code
Low Pressure	200kPa	71468540
High Pressure	2,800kPa	71468580

COMET™ EDGE OXY/ACETYLENE REGULATORS

- Regulators incorporating advanced design, proven performance, and unsurpassed safety
- Engineered for professional applications
- Suitable for the majority of cutting, welding and heating applications
- Gas guard nipple ensures total gas shut off in the event that the inlet connection is broken
- Colour coded for easy identification
- Vertical inlet



71460022

71460042

Item Code	Description	Max. Outlet Pressure	Bishops Code
310532	ESV4 Acetylene Regulator	150kPa	71460022
310637	ESV4 Oxygen Regulator	1,000kPa	71460042

MIG & TIG SHIELDING GAS REGULATORS

- Argon and Argon/CO₂ mixture regulators are designed for use with MIG and TIG welding processes
- Outlet Connection: 5/8"-18 UNF RH Ext



71464102



71464100



Item Code	Description	Rated Air Flow	Max. Outlet Pressure	Inlet Connection	Bishops Code
201031	Argon	30L/min	345kPa	5/8" BSP -18 Type 10 Side	71464100
301526	Argon, Ar/CO ₂	40L/min	400kPa	AS 2473 Type 10 (5/8" BSP RH Ext)	71464102

COMET™ NITROGEN HIGH PRESSURE WELDING REGULATOR

- Specifically designed for high pressure applications
- Designed for cylinder fill pressures up to 31,500kPa
- Encapsulated seat with protective sintered filter
- Tube outlet connectors designed to prevent accidental connection of low pressure equipment
- Individually tested and set to a maximum delivery pressure
- Connection outlet: 1/4" tube fitting
- Max. outlet pressure: 20,000kPa
- Rated air flow: 2,000L/min
- Gauge range: 50,000kPa (inlet), 30,000 kPa(outlet)
- Connection inlet : AS2473 Type 11 (5/8" BSP RH Ext)



Item Code	Bishops Code
301565	71460048

ARGON FLOWMETER REGULATOR



- Brass fittings
- Max. inlet pressure: 25,000kPa @ 15°C
- Includes 2 x dial indicators for pressure and flow



Item Code	Bishops Code
201-50LM-AR	71464120

FAST FACTS – GAS HEATING



For light duty heating & burning applications a LPG only set up will suffice.

For heavy duty applications, mixed gas equipment can be employed. Oxy/LPG and Oxy/Acetylene will both produce a much higher flame temperature than LPG alone.

- **Oxy/LPG** is an ideal combination in high heat applications, as LPG creates a higher heat in the secondary flame.
- **Oxy/Acetylene** releases the majority of its heat in the primary flame, giving it a more concentrated heat output.

CO2 REGULATOR & FLOWMETER

- Suitable for MIG/TIG applications
- Single stage construction
- Forged brass body for maximum strength
- Chrome bonnet
- Neoprene diaphragms
- Sintered metal inlet filter to trap impurities
- Accurate gas flow regulator
- Safety relief valve is set for all gases
- No soldered joints, for easy maintenance
- Flowmeter with easy-to-read tube and transparent polycarbonate outer cover for impact resistant
- Side entry
- Flow rate: 25L/min
- Max. working pressure: 315bar



Item Code	Bishops Code
101-25FL-CD	71464110



WELDING TIPS & HEATING NOZZLES

WELDING & ABRASIVES

STANDARD GAS WELDING TIPS

- Swaged welding tips
- Suitable for oxygen/acetylene fuel gases



Tip Size	Steel Thickness	Bishops Code	Tip Size	Steel Thickness	Bishops Code
No. 8	2mm	71430080	No. 15	5-6.5mm	71430150
No. 10	2.6mm	71430100	No. 20	8.2-10mm	71430200
No. 12	3.2-4mm	71430120	No. 32	25mm	71430320

ACETYLENE HEATING NOZZLE

- MG-H Series
- Suits MG-243 mixer



Item Code	Bishops Code
MH-H	71425020

GAS EQUIPMENT CONFIGURATION GUIDE

Whether you're welding, cutting, gouging or heating, you'll need to configure your gas set up carefully. Each set up will need different components, and you can find them all right here at Bishops.

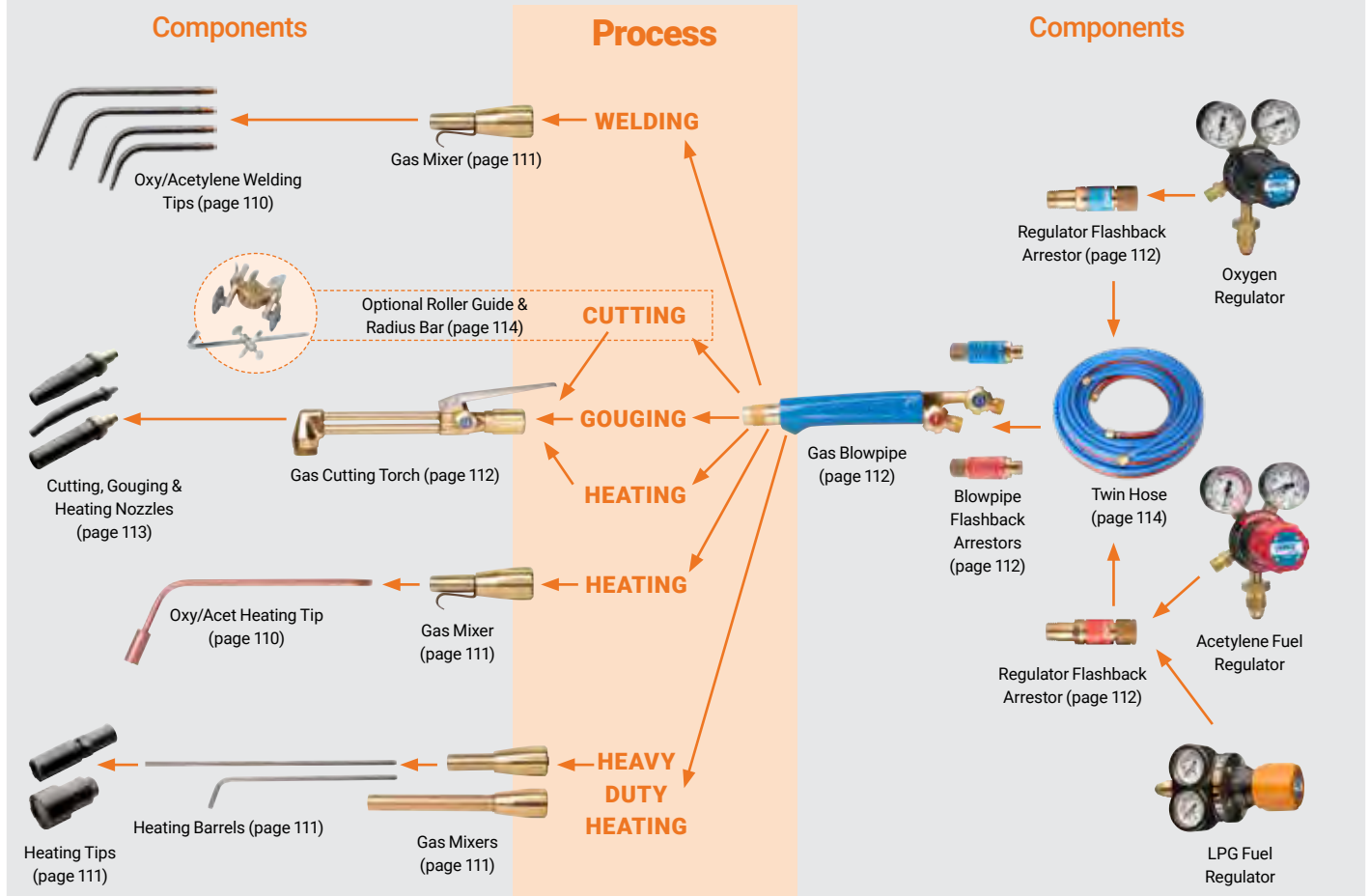

If you can't find what you need in these pages, give us a call and we'll get it for you.

LPG/GAS HEATING TIPS

- Suit HE-505
- Designed with flame release slots to prevent forced flash back of oxygen/fuel gas
- Use with 2393 stainless steel heating tube
- Assemble with F-43 mixer and 43-2 torch handle



71425510



71425030

Description	Tip Size	Oxygen Pressure	Oxygen Flow	Propane Pressure	Propane Flow	Heat Output	Bishops Code
2290-2H	1.1 x 25mm	2-3kg/cm ²	5.9-12.8L/min	0.5kg/cm ²	1.5-3.2L/min	33.5 x 106-71.4 x 106cal/hr	71425510
2290-3H	1.3 x 25mm	3-4kg/cm ²	8.5-22.9L/min	1kg/cm ²	2.2-5.7L/min	49 x 106-127.1 x 106cal/hr	71425512
2290-4H	1.1 x 33mm	4-5kg/cm ²	14.2-28.4L/min	1kg/cm ²	3.6-7.1L/min	80.3 x 106-158 x 106cal/hr	71425514
2290-5H	1.3 x 33mm	5-6kg/cm ²	17-39.7L/min	1-2kg/cm ²	4.3-10L/min	96 x 106-223 x 106cal/hr	71425516

ACETYLENE HEATING TIPS

- Suit 2290A05C



Description	Tip Size	Oxygen Pressure	Oxygen Flow	Acetylene Pressure	Acetylene Flow	Heat Output	Bishops Code
Acetylene 8 x 12	2290-1HA	150kPa	45-58L/min	100kPa	41-55L/min	180MJ/hr	71425050
Acetylene 12 x 12	2290-2HA	200kPa	74L/min	100kPa	65L/min	215MJ/hr	71425060

LPG HEATING TORCH KIT

- HE-505 heating torch with 4 tips
- Standard lengths: 650mm/750mm/1,050mm/1,250mm
- Oxy pressure: 3.5-5.0kg/cm²
- Propane pressure: 0.4kg/cm²
- Oxy consumption: 9,000-16,000L/hr
- Propane consumption: 2,200-4,000L/hr
- Range: 5-50mm
- Tip sizes: 1.1 x 25, 1.3 x 25, 1.1 x 33 and 1.3 x 33

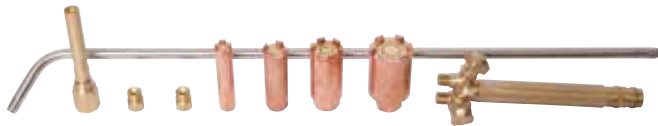

Item Code	Bishops Code
HE-505-BI	71480130

WELDING & HEATING MIXER

- Suits Morris Blowpipe Hand Piece (MG-241) type 550
- Acetylene gas mixer
- Hose connection: 3/8"-26N
- Length: 10mm



Item Code	Bishops Code
MG-243	71480340

HEATING MIXER

- Suits Morris Blowpipe Hand Piece (MG-241) type 570
- Fitted with securing clip
- Length: 13mm



Item Code	Bishops Code
MG-343	71480345

GET MORE AT BISHOPS ▶

SAFETY & WARNING SIGNS

Page 54



BLOWPIPES & FLASHBACK ARRESTORS

WELDING & ABRASIVES

BLOWPIPE HAND PIECE

- Medium duty handle
- Hose connection: 5/8"-18N
- Cuts up to 150mm and welds up to 9mm
- Lightweight and comfortable aluminium coated handle
- Comes with two high quality brass and stainless steel needle valves with internal springs
- Locking teeth allow the handle to lock into position tightly
- Fits cutting attachment MG-242 or MG-342



Item Code	Bishops Code
MG-241	71480320

COMET™ 3 HEAVY DUTY BLOWPIPE & CUTTING ATTACHMENT



COMET™ 3 Blowpipe:

- Suitable for fusion and braze welding, brazing, soldering, heating, hand cutting, sheet metal cutting, rivet cutting, powder facing and flame cleaning

COMET™ Cutting Attachment:

- Attaches quickly and easily to the COMET™ 3 blowpipe by hand
- Suits oxy/acetylene, oxy/LP gas or oxy/natural gas
- For use with Type 41 and 44 nozzles



71480322



71480362

Item Code	Description	Bishops Code
304001	Blowpipe	71480322
304005	Cutting Attachment	71480362

CUTTING ATTACHMENT

- Type 41 nozzle
- Cuts up to 150mm/6"
- Stainless steel needle valve provides fast and accurate flame adjustment
- Locking teeth allow the handle to lock into position tightly
- The double O-ring seal forms a gas-tight seal
- Fitted with a press lever for easy cutting use
- Special design twin tubes with mixer
- Suits Morris Blowpipe Hand Piece (MG-241) hand piece
- Length: 285mm

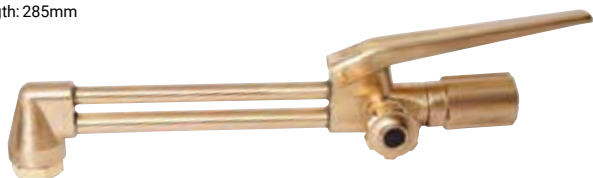

Item Code	Bishops Code
MG-242	71480360

HAND CUTTING TORCH

- Heavy duty cutting torch
- Stainless steel lever and needle valves
- 90° angle head
- Comes with adaptors
- Cutting capacity: 3-300mm
- Length: 500mm



Item Code	Bishops Code
1601A	71480140

WELDING FLASHBACK

Avoid A Nasty Flashback!

Always use fit-for-purpose flashback arrestors with all common gas fuel systems. If flashback arrestors are not used, possible flashbacks will not be stopped and have the potential to cause major property damage and injury.

For hoses 3 metres or less, flashback arrestors should be fitted to each gas line at the regulator outlet. For hoses over 3 metres, two flashback arrestors should be fitted to each gas line, one at the blowpipe connection and one at the regulator outlet.

All flashback arrestors must comply with Australian Standard AS4603 to be sold on the Australian market. Flashback arrestors need to be tested at least every 12 months to make sure that they are still working effectively.

FLASHBACK ARRESTORS



- Single piece type arrestors with non-return valve, flame arrestor and dust filter
- Suitable for small flow rate applications
- EN 730-1:2002
- Max. working pressure: 15bar (oxy/compressed air), 1.5bar (acetylene), 3.5bar (hydrogen), 5bar (fuel/gas)
- Length: 51.5mm
- Diameter: 21mm



71435100 71435200 71435300 71435400

Description	Bishops Code
To Suit Oxygen Torch	71435100
To Suit Gas Torch	71435200
To Suit Oxygen Regulator	71435300
To Suit Gas Regulator	71435400

COMET™ FLASHBACK ARRESTORS



- Provides protection against flashbacks, backfires and sustained backfires
- NV - Non-Return Valve prevents reverse flow of gases
- FA - Stainless Steel Flame Arrestor extinguishes any returning flame
- TV - Gas flow will be shut-off if arrestor becomes overheated
- DF - Dust Filter protects the gas non-return valve against contamination
- Standards compliant to AS4603; ISO 5175-1; UL 1357



Torch Mount Regulator Mount

Item Code	Description	Mount	Bishops Code
208516	FBA COMET - Oxygen	Regulator	71435302
208517	FBA COMET - Fuel	Regulator	71435402
208514	FBA COMET - Oxygen	Torch	71435102
208515	FBA COMET - Fuel	Torch	71435202

FAST FACTS – CYLINDER FALL PROTECTION

Snap Safe & Gas Guard are safety features designed to reduce the risks and hazards that can occur if a welding gas cylinder topples over due to incorrect storage, placement or handling.

If the gas regulator on top of a cylinder breaks off during a fall, potentially explosive gas under high pressure can escape rapidly, turning your cylinder into an unguided missile. These features ensure gas shut off if the inlet connection is broken.

Always properly secure and regularly inspect your gas cylinders!

LPG CUTTING TIPS

- Type 44 BOC style



Item Code	Cutting Capacity	Bishops Code
44-8	5–10mm	71420708
44-12	20–50mm	71420712
44-15	50–80mm	71420715

OXY/ACETYLENE GAS CUTTING MACHINE NOZZLES

- Divergent type nozzles with stainless steel insert screwed into tip end of the cutting oxygen port
- Maintains a constant high quality cutting performance that also improves nozzle life



71270702

Item Code	Size	Plate Thickness	Bishops Code
306116	1	10–15mm	71270700
306117	2	15–30mm	71270702
306118	3	30–40mm	71270704
306119	4	40–50mm	71270706



CUTSKILL GAS CUTTING NOZZLES



- Type 41 oxy/acetylene
- Economical alternative to the COMET™ range
- Two seat designed nozzles for use with COMET™ 3, multi-purpose and sabre cutting torches
- Manufactured from copper for better heat resistance



71420258

Item Code	Size	Cutting Thickness	Fuel/Gas Flow Rate @ 100kPa	Oxy Flow Rate	Bishops Code
206047	8	6–10mm	3.5L/min	20L/min @ 200kpa	71420258
206048	12	12–20mm	4.0L/min	38L/min @ 200kpa	71420260
206049	15	25–75mm	7.0L/min	75L/min @ 350kpa	71420270
206050	20	100–125mm	9.0L/min	134L/min @ 400kpa	71420275

COMET™ TYPE 41 OXY/ACETYLENE CUTTING NOZZLES



- Type 41 nozzles
- Wider seating areas ensure gas tight seals with less tightening
- Protective flange to safeguard tapered seat from damage
- Consistent high quality performance and long nozzle life
- Less slag adhesion
- Individual flame testing of COMET™ nozzles guarantees consistent high quality performance



Item Code	Size	Cutting Thickness	Fuel/Gas Flow Rate @ 100kPa	Oxy Flow Rate	Bishops Code
306051	24	150–200mm	20L/min	420L/min @ 600kPa	71420280

TYPE 41 ACETYLENE CUTTING TIPS



- For 1600B and MG-242 cutting torch and cutting attachment
- One piece
- Length: 72mm



Tip Size	Cutting/Plate Thickness	Oxygen Pressure	Acetylene Pressure	Bishops Code
No. 6	1.0–5mm	1.5bar	0.5bar	71420060
No. 8	5.0–10mm	1.5bar	0.5bar	71420080
No. 12	20–50mm	2.5bar	1.0bar	71420120
No. 15	50–80mm	2.5bar	1.0bar	71420150
No. 20	80–100mm	3.0bar	1.5bar	71420200
No. 32	150–200mm	4.0bar	1.5bar	71420250

GET MORE AT BISHOPS

FLAMMABLE LIQUID STORAGE CABINETS

Page 320





CUTTING & GOUGING TIPS, GUIDES, WELDING HOSES & ACCESSORIES

WELDING & ABRASIVES

CUTSKILL CUTTING & GOUGING TIPS

- Suits Cutskill Plasma
- Pack of 5



71270000

Item Code	Size	Amperage	Bishops Code
CUTTING TIPS			
CSP337001	0.8mm	35A	71270000
CSP337002	0.9mm	45A	71270001
CSP337095	1.1mm	60A	71270002
GOUGING TIPS			
CSP337096	1.1mm	60A	71270005

TYPE 41 BENT GOUGING TIPS

- Oxy-Acetylene gouging tips
- For MG-242 and 1600B cutting torches
- One piece
- 7 holes medium preheat
- For gouging and weld removal
- Length: 100mm



Tip Size	Cutting/Plate Thickness	Oxygen Pressure	Acetylene Pressure	Bishops Code
MG-32GB	8mm	5.0bar	1.0bar	71432080
MG-48GB	11mm	5.5bar	1.0bar	71432110
MG-64GB	13mm	6.0bar	1.0bar	71432130

CUTSKILL PLASMA ACCESSORIES

Suitable for:

- 35/45A Plasma
- 60A Plasma Torch



71280431



71280432

Item Code	Description	Bishops Code
CSP337005	Shield Cup	71280431
CSP337004	Stand-Off Guide	71280432

ROLLER GUIDES

- Combination Roller/Circle Guide For COMET™ Torches
- Can be fitted to COMET™ torches to allow accurate control whilst cutting straight lines and circles



Item Code	Bishops Code
308354	71470140

TWIN WELDING RUBBER HOSES



- Highly resistant to abrasion and flame
- Black/blue hose for oxygen, and red hose for fuel gas
- Includes fittings



Gas Type	Colour	Length	Nominal Bore Diameter	Bishops Code
Oxy/Acetylene	Black & Red	4.5m	¼"	71450520
Oxy/Acetylene	Black & Red	6m	¼"	71450530
Oxy/Acetylene	Black & Red	10m	¼"	71450540
Oxy/Acetylene	Blue & Red	20m	¼"	71450546

OXY/ACETYLENE WELDING HOSE

- Oxygen/acetylene
- Resistant to abrasion and flame
- Blue and red colour coding
- Normal bore diameter: 5mm
- Sold per metre



Bishops Code
71450580

COMET SINGLE INERT RUBBER ARGON WELDING HOSE

- 5mm diameter
- Sold per metre
- Black
- Compliant to AS1335



Item Code	Bishops Code
7904520	71450590

ACETYLENE COUPLING

- LP240
- Left hand coupling
- Brass



Item Code	Bishops Code
18-LP240	71450090

NUT & TAIL CONNECTORS

- GA5 type
- Left hand and right hand options



Item Code	Description	Bishops Code
GCWA45	Left Hand	71450040
960-R	Right Hand	71450050

OXY/ACETYLENE HOSE CONNECTOR KIT **CIGWELD**

- Screw type
- 5mm



Item Code	Bishops Code
LP265	71450020

HOSE JOINERS **CIGWELD**

- 5mm
- 5/8-18 UNF
- Male both ends



Item Code	Description	Bishops Code
WB34	RH	71450010
WB35	LH	71450020

BUTANE GAS TORCH KIT

- Butane gas canister with burner handle
- Adjustable flame
- Manual ignition



Description	Bishops Code
Butane Torch Kit	71450592
200g Butane Gas Refill	71450595

15 PIECE OXY/ACETYLENE WELDING & CUTTING KIT **MORRIS**

- Contains tools that can cut up to 150mm/6" and weld up to 9mm/3/8" steel
- Suitable for welding, brazing, soldering, hard facing, heat treating, priming, descaling, scarfing, gouging, flame cleaning, rivet washing and cutting

Includes:

- Torch handle, cutting attachment and mixer
- #6, #8, #10, #12, #15, #20, #26 and #32 welding tips
- 8, 12, 15 and 20 type 41 cutting tps
- 3/8"-18N hose nut
- Twin wheel circle guide
- Supplied in a durable blowmold tool case



Item Code	Bishops Code
GCW-30P	71410040

CUTSKILL TRADESMAN PLUS OXY/ACETYLENE WELDING KIT **CIGWELD**

- Value priced outfit
- Everything you need for oxy/acetylene gas cutting or welding

Includes:

- CutSkill oxygen regulator
- CutSkill acetylene regulator
- CutSkill blowpipe
- CutSkill cutting attachment
- CutSkill mixer
- 2 x flashback arrestors – F2R & F6
- 3 x cutting nozzles – 8, 12 & 15
- 3 x welding tips – 8, 12 & 15
- Heating tip – 8 x 12HT
- Gas welding goggles
- Twin gas hose – 10m
- Roller guide and radius bar
- Tip cleaners
- Flint lighter



Item Code	Bishops Code
208007	71410031

COMET™ EDGE PROFESSIONAL PLUS OXY/ACETYLENE WELDING KIT **CIGWELD**

- Designed for professional gas cutting, welding and heating applications
- Gas Guard safety feature fitted to the regulators as standard
- Components comply with the relevant clauses of AS 4839

Includes:

- COMET™ Edge ESV4 oxygen regulator
- COMET™ Edge ESV4 acetylene regulator
- COMET™ 3 blowpipe
- COMET™ 3 cutting attachment
- COMET™ 3 mixer assembly
- 4 x cutting nozzles – size 6, 8, 12 & 15
- 5 x welding tips – size 8, 10, 12, 15 & 20
- Heating tip – size 8 x 12HT
- Tip cleaners
- Twin gas hose – 5m
- F6 blowpipe flashback arrestor
- F2R regulator flashback arrestor
- Roller guide
- Flint lighter
- Combination spanner
- Gas welding goggles
- Stainless steel toolbox



Item Code	Bishops Code
308313	71410032



WELDING & CUTTING KITS & SOLDERING PRODUCTS

WELDING & ABRASIVES

WELDING & CUTTING KITS

- Applications include precise welding, brazing, soldering, hard facing, heating/treating and priming, straightening, descaling and scarfing, gouging, flame cleaning, rivet washing and cutting
- Cuts up to 150mm, welding up to 9mm steel
- Torch handle has two needle valves for fast, accurate flame adjustment and resists backfire
- Special design locking teeth enables reposition and locking strength
- Two separate gas tubes for safety
- Aluminium coated makes handle lighter and more comfortable
- Cutting attachment has double O-rings seal for quick, hand tight connection and leak free
- Press lever for easy cutting use
- Swaged copper welding tips for best flame characteristics

Includes:

- Torch handle, cutting attachment, mixer, oxygen and acetylene regulators, as well as welding, heating and cutting tips
- Complete accessory package including hose, sparklighter, goggles, tip cleaner and replacement O-rings and seals
- Supplied in a steel tool box



Item Code	Description	Bishops Code
GCW24-TB	Oxygen/Acetylene Kit	71410030
GCW24-TB-BIA	Oxygen/Propane Kit	71410050

FAST FACTS – WELDING & CUTTING GASES

Different Welding Gases

Oxy/Acetylene

The combination of oxygen and acetylene gives a concentrated heat output for quick piercing and cutting of materials. It is versatile and able to be used in most welding jobs. In comparison to alternatives, oxy/acetylene can be expensive and unstable.

Oxy/LPG

Oxygen and LPG is ideal for high heat applications, as the secondary flame creates a higher heat. Overall, this gas combo is easy to source, relatively inexpensive and stable. Although it creates a hotter flame, the heat is not as focused making piercing slower.

SOLDERING IRONS

- Pre-tinned tip is ready for use
- No tip preparation required
- Good thermal conductivity – heats quickly
- Electroplated copper tip for extended life
- Rugged long-life element
- Stainless steel components provide corrosion resistance and extended life
- Stay cool handle – provides user comfort even after long periods of use
- Cushion Comfort Grip on models 15W, 25W, 40W and 80W
- Temperature range: 400°C
- Made in Australia



Item Code	Description	Voltage	Output Power	Hertz	Length	Bishops Code
SP25DAU	Light Home & Hobby Work	240V	25W	50Hz	210mm	75095025
SP40DAU	General Home Soldering, Electrical Wiring & Connections	240V	40W	50Hz	210mm	75095040
SP80DAU	Electrical Soldering, Light Alloy or Metal Soldering	240V	80W	50Hz	238mm	75095080
SP120DAU	Medium Duty, Heavy Electrical Connections, Light Sheetmetal Work	240V	120W	50Hz	289mm	75095120
SP200DAU	Heavy Duty, Heavy Sheetmetal Assembly Includes Stand	240V	250W	50Hz	350mm	75095250

SOLDERING IRON

- 3.3V
- 20-100W
- Low voltage safety
- Automatic switch off
- PSU transformer sold separately



Item Code	Bishops Code
SS	75095910

RESIN CORE SOLDER

- 500g spool
- Multi-purpose solder
- Recommended for working with electrical wiring, copper and tin



Description	Diameter	Bishops Code
Grade C 40/60	2.3mm	72030123
Grade C 40/60	3.2mm	72030132
Grade F 50/50	1.6mm	72030316
Grade F 50/50	2.3mm	72030323
Grade F 50/50	3.2mm	72030332
Grade KP 60/40	0.71mm	72030407
Grade KP 60/40	1.2mm	72030412
Grade KP 60/40	1.6mm	72030416
Grade KP 60/40	2.3mm	72030425
Grade KP 60/40	3.25mm	72030432

COMWELD 40/60 SOLDER

- Comweld 40/60 Solder is a low cost general purpose solder
- Suitable for general sheet metal work, plumbing such as gutters and flashings and automotive radiator repairs
- Flux cored
- 15g



Item Code	Bishops Code
322220	71880355

PLUMBERS SOLDER BARS

- Tin-lead alloy
- An ideal electrical grade solder
- 250g per stick



Description	Bishops Code	Description	Bishops Code
Grade H 35/65	72010035	Grade F 50/50	72010050
Grade C 40/60	72010040	Grade KP 60/40	72010060

FINE RADIATOR SOLDER

- 38/2/60
- 12 sticks per kilogram



Item Code	Bishops Code
174350	72020038

SOLDERING FLUIDS & PASTE

Soldering Fluid:

- General purpose flux for soldering, copper, brass, tin plate, tinned metal and clean steel sheet

Soldering Paste:

- For when a fluid is not practical in soldering copper, brass, small tinned parts and for electrical work



Description	Size	Bishops Code	Description	Size	Bishops Code
Soldering Fluid	250ml	71205040	Soldering Paste	150g	71205510
Soldering Fluid	500ml	71205060	Soldering Paste	400g	71205520
Soldering Fluid	1L	71205080	-	-	-

SOLDERING FLUID

- Highly active, universal brazing flux for soldering difficult metals such as stainless steel, monel, nickel and more
- 250ml



Item Code	Bishops Code
90240647	71215040

COMWELD FLUX

Comweld 965

- When used in conjunction with Comweld Soft Solders, enables excellent joints to be made on almost all metals and combinations of metals

Comweld Aluminium

- All purpose flux for fusion welding sheet and cast aluminium
- Eliminates the need for a number of different types of aluminium welding alloys

Comweld General Purpose SBA Silver

- Recommended for use with Cadmium bearing and Cadmium free brazing alloys with a low to medium silver content
- Excellent flux for medium to high temperature brazing
- For silver brazing of carbon steel, stainless steels and dissimilar metals

Comweld SBA No. 2

- High silver content, produce excellent joints on carbon steel, stainless steel, nickel alloys and copper and brass
- Used in a paste form

Comweld Copper & Brass

- Specially developed for the braze welding of copper, brass, and bronze and the brazing of copper and steel



Item Code	Description	Size	Bishops Code
321890	Comweld 965	125ml Bottle	71880360
321740	Comweld Aluminium	250g	71880372
321850	Comweld GP SBA Silver	200g	71880375
321840	Comweld SBA No. 2	200g	71880365
321822	Comweld Copper & Brass	250g	71210060

CHROMEBRIGHT PICKLING PASTE

- 2.5kg bucket



Item Code	Bishops Code
321918	71895130

GET MORE AT BISHOPS



SPILL KITS

From Page 41



ANTI-SPATTER & WELDING ACCESSORIES

ANTI-SPATTER NOZZLE DIP

- Nozzle Dip is a non-toxic gel used to help prevent welding spatter adhering to sensitive torch components such as nozzles, contact tips etc.
- Simply dip the hot nozzle 1cm into the nozzle dip as required



Item Code	Bishops Code
707958	71895120

SINGLE FLINT GUN LIGHTER

- Produces a spark that easily ignites any flame source but quickly extinguishes, in order to ensure a safe, controlled flame
- A compact and economical alternative to matches and butane lighters
- Single flint cup type lighter
- Flat file
- Replacement flints available



Description	Bishops Code
Flint Gun Lighter	71440020
Replacement Flints - 10 Pack	71440075

OXY/ACETYLENE BOTTLE KEY

- Spanner-style key for use on oxy/acetylene bottles
- Easily fits into any tool box
- Comes with a hole in the end for easy storage on a hook or key ring



Bishops Code
71440320

TIP CLEANER SET

- Foldable tip cleaner
- 201 Stainless steel



Item Code	Bishops Code
I0-TC13G	71440520

WELDER'S CHIPPING HAMMER

- Spring grip
- Used for the removal of slag and spatter around welds



Bishops Code
71250100

WELDER'S CHIPPING HAMMERS

- Used for chipping off slag and spatter around welds, especially in holes and difficult corners
- Head forged from first grade high carbon spring steel
- Sharp, finely pointed ends are heat treated for longevity
- Head is properly balanced on the handle and is comfortable to work with
- Rubber grip handle for comfort and insulation from radiant heat whilst welding
- Spring grip handle to lessen shock, with a loop to attach a lanyard
- Handle size: 260mm



Item Code	Description	Weight
5WHRG	Rubber Grip	3.2kg
5WHSP	Spring Grip	4.5kg

SPECIAL ORDER: PLEASE QUOTE ITEM CODE UPON ORDERING THIS PRODUCT

MIG PLIERS

- High quality MIG welding pliers
- Specifically designed for MIG welding applications
- Overall length: 210mm



Item Code	Bishops Code
WSPLIER	71270663

WRAP A ROUND CURV-O-MARK

- Inexpensive tool for marking straight lines around pipe or for use as a straight edge
- Flexible gasket material construction with good resistance to heat and cold
- Imprinted with inches and millimeters



Size	Width	Length	Fit Pipe Size	Bishops Code
Medium	100mm/3.88"	914mm/3'	3"-6"/80-150mmNB	60080922
Large	100mm/3.88"	1,830mm/6'	3"-10"/80-250mmNB	60080924
X-Large	127mm/5"	2,134mm/7'	4"-12"/100-300mmNB	60080926
X-Large	127mm/5"	2,743mm/9'	6"-16"/150-400mmNB	60080928

THE COMPLETE ABRASIVES CHEAT SHEET

Don't let abrasives grind you down. Glide through them without any friction using this handy cheat sheet.

Specification Breakdown

All abrasive discs are manufactured with a specification that allows you to quickly identify features about the disc. The following diagram, based on EN 12413, will make it easy for you to find the abrasives you need to get the job done. Remember, each manufacturer may do things differently, so be sure to check out their guides!

41	A	46	R	BF	60
Shape/Profile	Abrasive Type	Grit Size	Hardness Grade	Bond Type	Max. Operating Speed
41 – Flat 42 – Depressed Centre 27 – Depressed Centre (Grinding)	A – Aluminium Oxide C – Silicon Carbide ZA – Zirconium Alumina CO – Ceramic Oxide	Fine – 80–100 Medium – 30–60 Coarse – 16–24	A – Z Classified using the alphabet from softest to hardest (A to Z). Check supplier specs for more details.	B – Fibre reinforced resinoid bond with cloth BF – Resinoid bond & other duroplastic organic bonds	Maximum operating speed of disc (rpm). Do not exceed this speed.

Put It To Practice

Abrasive Type

- Aluminium Oxide** Most common abrasive. Good for grinding carbon steel, alloy steel, high speed steel, annealed malleable iron, wrought iron and bronzes.
- Silicon Carbide** Used for grinding grey iron, chilled iron, brass, soft bronze and aluminium as well as stone, rubber and other non-ferrous materials.
- Zirconium Alumina** Tough and durable for rough applications such as cut-off operations on a broad range of steels and steel alloys.
- Ceramic Oxide** High purity, fractures at a controlled rate at the sub-micron level, hard and strong. Used for demanding applications on steel and alloys.

Grit Size

- Abrasive Grade** Grit size simply refers to the abrasive grade of a product. In general, the higher the grade, the smaller in size the abrasive grain is and the smoother the finish will be.

Hardness Grade

- Soft Grade** Designed to release new grains quickly, will remove the maximum stock while creating the least amount of heat in the base material.
- Hard Grade** Slowly sheds its dull grains making it durable. Removes less stock than its soft grade counterpart but increases the amount of heat in the base material.

Bond Type

- Vitrified** Rigid, strong and porous. Not affected by water, acid, oil or variations in temperature.
- Resinoid** Synthetic resin, suitable for applications that require rapid stock removal and where a cleaner finish is required. Designed to operate at high speeds.
- Rubber** Offers smooth grinding action, suitable for applications that require a smooth finish.

CUT & GRIND A LOT?
 Ask Bishops how **BUY BULK & SAVE** can help you save money in the workplace.

GET MORE AT BISHOPS ▶

ELECTRIC ANGLE GRINDERS

Page 138





CUT-OFF & GRINDING DISCS SAFETY



✓ Dos

Handle and store discs carefully. If possible, keep discs in their original packaging

Inspect your discs for any damage before mounting. If damaged, dispose of the disc

Use a safety guard that is correctly positioned and secured

Always ensure your equipment is switched 'off' and unplugged from the socket before changing the disc

Ensure the speed of your equipment does not exceed the maximum operating speed printed on the disc

Let newly mounted discs run at operating speed for a reasonable time before any cutting or grinding

Always wear appropriate personal protective equipment such as safety glasses or goggles, dust mask, gloves, ear plugs and safety shoes

Ensure work piece is firmly secured while it is being cut or grinded

Keep your working area clutter-free around any cutting or grinding operations

✗ Don'ts

Don't store discs in any situation in which they may become damaged, such as damp atmospheres or extreme temperatures

Don't use or mount a damaged disc

Don't exceed the maximum operating speed printed on the disc

Don't force discs onto your equipment

Don't use discs without proper ventilation

Don't apply extreme pressure to the disc so that the driving motor decelerates

Don't stop the disc by applying pressure to the edge or face. Instead switch off equipment and allow disc to stop revolving

Don't let disc become trapped or pinched in the cut

Don't use a machine that is in poor mechanical condition

Don't forget to wear appropriate personal protective equipment such as safety glasses or goggles, dust mask, gloves, ear plugs and safety shoes

**For more information or any safety related questions, contact your Industrial Safety Experts today!
Call your local Bishops branch or visit www.bishopbros.com.pg**

ULTRA-THIN CUT-OFF WHEELS

- Ultra-thin for fast, precise cutting
- Iron-free
- Complies with Australian Standard AS1788.1-1987 and EN12413
- Specifications: 41 A54 P BF
- Abrasive type: Aluminium oxide
- Disc type: Pressed – flat
- Grade: Medium
- Suitable for most metals particularly steel and INOX (stainless steel)



Diameter	Thickness	Bore	Max. Speed	Bishops Code
100mm	1.0mm	16mm	15,300rpm	65021020
115mm	1.0mm	22mm	13,300rpm	65021045
125mm	1.0mm	22mm	12,250rpm	65021060

ULTRA-THIN TRADIES CUT-OFF DISCS

- Available in ultra thin 1.00mm thickness for quick burn free cutting to 2.5mm for more durable applications
- All wheels are reinforced for the demanding nature of cutting-off metals or masonry with right angle grinders
- Ultra thin fast cut reinforced straight wheel for fast cutting off where minimal material loss is desired
- For stainless steel, metal, aluminium, copper, non ferrous metals, masonry, concrete, tiles, PVC, rubber and timber
- Durable resin bond designed for fast cut while retaining excellent wheel life
- C60T – Premium grade Silicon carbide grain



Item Code	Specification	Dia. x Thick x Bore	Max. Speed	Bishops Code
66253370634	C60T-BF41	100 x 1.0 x 16mm	15,300rpm	65011250
66253370635	C60T-BF41	115 x 1.0 x 22mm	13,300rpm	65011255
66253370636	C60T-BF41	125 x 1.0 x 22mm	12,250rpm	65011260

METAL CUT-OFF WHEELS

- Suitable for steel, structural steel and cast iron
- Complies with ANSI B7.1 and O.S.H.A. regulations



Description	Diameter	Thickness	Bore	Max. Speed	Bishops Code
A36TB	100mm	2.5mm	16mm	15,300rpm	65010020
A24R	115mm	2.5mm	22mm	13,300rpm	65010040
A36TBF	125mm	2.5mm	22mm	12,200rpm	65010060
A24RBF	180mm	3.0mm	22mm	8,500rpm	65010080
A24RBF	230mm	3.0mm	22mm	6,600rpm	65010100
A24RBF	250mm	3.2mm	25mm	6,100rpm	65010140
A24RBF	305mm	3.2mm	25mm	5,100rpm	65010160
A24HS	305mm	3.8mm	22mm	5,100rpm	65010180
A24RBF	350mm	3.2mm	25mm	4,300rpm	65010200
A24RBF	355mm	3.8mm	25mm	4,300rpm	65010210
A24RBF	405mm	3.2mm	25mm	3,800rpm	65010220
BR054968	400mm	4.5mm	25mm	3,800rpm	65010240

FLAT CUT-OFF DISCS

- Right angle cut-off wheel line consists of Type 01 straight and Type 27 depressed centre cut-off wheels from 100mm to 230mm diameters
- All wheels are reinforced for the demanding nature of cutting-off metals or masonry with right angle grinders
- Fast cut reinforced straight wheel for cutting off
- For steel and hard ferrous metals
- Durable resin bond designed for fast cut while retaining excellent wheel life
- A36S – Aluminium oxide grain



Item Code	Specification	Dia. x Thick x Bore	Max. Speed	Bishops Code
66252841558	FH38-A36S-BF41	100 x 2.5 x 16mm	15,300rpm	65011020
66252841560	FH38-A36S-BF41	115 x 2.5 x 22mm	13,300rpm	65011040
66252841561	FH38-A36S-BF41	125 x 2.5 x 22mm	12,250rpm	65011060
66252841566	FH38-A36S-BF41	180 x 2.5 x 22mm	8,500rpm	65011080
66252841574	FH38-A36S-BF41	230 x 2.5 x 22mm	6,650rpm	65011100
66252841576	FH38-A36S-BF41	230 x 2.5 x 25.4mm	6,650rpm	65011120

HI-SPEED EASY CUTTING CUT-OFF DISCS

- High speed cut-off abrasive wheels provide the industry's leading performance in all high speed gas and electric-powered portable cut-off saws for asphalt, concrete, ductile and metal applications
- Easy cut reinforced straight wheel for cutting off
- For structural steel bar and hard ferrous metals
- Durable resin bond designed for fast cut while retaining excellent wheel life
- A30Q – Aluminium oxide medium grit medium hardness



Item Code	Specification	Dia. x Thick x Bore	Max. Speed	Bishops Code
66252919916	1HU700QR	406 x 4.0 x 25.4mm	4,800rpm	65011200

FLAT HIGH PERFORMANCE CUT-OFF DISCS

- Right angle cut-off wheel line consists of Type 01 straight and Type 27 depressed centre cut-off wheels from 100 to 230mm diameters
- These wheels come in ultra thin 1.00mm thickness for quick burn free cutting to 2.5mm for more durable applications
- All wheels are reinforced for the demanding nature of cutting-off metals or masonry with right angle grinders
- Ultra thin fast cut reinforced straight wheel for fast cutting off where minimal material loss is desired
- For stainless steel, alloy steels & hard ferrous metals
- Durable resin bond designed for fast cut while retaining excellent wheel life
- A46T – Mega Inox using premium grade Aluminium oxide grain



Item Code	Specification	Dia. x Thick x Bore	Max. Speed	Bishops Code
66252841585	A46T-BF41 M/INOX	100 x 1.0 x 16mm	15,300rpm	65021025
66252919966	A46T-BF41 M/INOX	115 x 1.0 x 22mm	13,300rpm	65021040
66252919991	A46T-BF41 M/INOX	125 x 1.0 x 22mm	12,250rpm	65021065
66252920062	A46T-BF41 M/INOX	230 x 2.0 x 22mm	6,650rpm	65021100

MASONRY CUT-OFF WHEELS

- All wheels are reinforced for the demanding nature of cutting-off metals or masonry with right angle grinders
- Fast cut reinforced straight wheel for cutting off
- For dry cutting of brick, concrete, ceramic and stone
- Durable resin bond designed for fast cut while retaining excellent wheel life
- C30T – Silicon carbide grain



Item Code	Specification	Dia. x Thick x Bore	Max. Speed	Bishops Code
66252841642	FH64 C30T-BF41	100 x 3.2 x 16mm	15,300rpm	65016020
66252841644	FH64 C30T-BF41	125 x 3.2 x 22.2mm	12,250rpm	65016025
66252841649	FH64 C30T-BF41	180 x 3.2 x 22.2mm	8,500rpm	65016040
66252841655	FH64 C30T-BF41	230 x 3.2 x 22.2mm	6,650rpm	65016060



GRINDING & CHOP SAW DISCS & WHEELS

METAL GRINDING DISCS

- For use on cast iron and steels
- Thickness: 6mm
- Grit: A24
- Complies with ANSI B7.1 and O.S.H.A. regulations



Diameter	Bore	Max. Speed	Bishops Code
100mm	16mm	15,300rpm	65014020
115mm	22mm	13,300rpm	65014040
125mm	22mm	12,200rpm	65014060
180mm	22mm	8,500rpm	65014080
230mm	22mm	6,600rpm	65014100

DEPRESSED CENTRE GRINDING DISCS **flexOvit**

- The depressed centre design allows the flange/lock nut to recess within the wheel so that it can be used for various grinding and cutting applications
- Depressed centre wheels are designed to handle the most severe right angle grinding applications from heavy stock removal to rough blending
- Excellent performance for fast stock removal
- For steel and hard ferrous metals
- Durable resin bond designed for grinding while retaining excellent wheel life
- A24S – Aluminium oxide grain



Item Code	Specification	Dia. x Thick x Bore	Max. Speed	Bishops Code
66252841705	A30S-BF27	100 x 6.0 x 16mm	15,300rpm	65015020
66252841709	A30S-BF27	115 x 6.0 x 22mm	13,300rpm	65015040
66252841682	A24/30T-BF27	125 x 6.8 x 22mm	12,250rpm	65015060
66252841689	A24/30T-BF27	180 x 6.8 x 22mm	8,500rpm	65015080
66252841695	A24/30T-BF27	230 x 6.8 x 22mm	6,650rpm	65015100

DEPRESSED CENTRE GRINDING DISCS **flexOvit**

- Depressed centre wheels are designed to handle the most severe right angle grinding applications from heavy stock removal to rough blending
- Excellent performance for fast stock removal
- For stainless steel and hard ferrous metals
- Durable resin bond designed for grinding while retaining excellent wheel life
- A30S – Aluminium oxide medium grit medium grade



Item Code	Specification	Dia. x Thick x Bore	Max. Speed	Bishops Code
66252841739	A30S-BF27 I/F	100 x 6.0 x 16mm	15,300rpm	65023020
66252841742	A30S-BF27 I/F	115 x 6.0 x 22mm	13,300rpm	65023040
66252841744	A24/30T-BF27 I/F	125 x 6.8 x 22mm	12,250rpm	65023060

FLAT CHOP SAW DISCS **flexOvit**

- Chop saw cut-off wheels are designed with finer grit, softer grades, and reinforcement layers that match the application
- Fast cut reinforced straight wheel for cutting off
- For stainless steel, ferrous metals, bar and tubing
- Durable resin bond designed for fast cut while retaining excellent wheel life
- A36SB – Aluminium oxide grain



Item Code	Specification	Dia. x Thick x Bore	Max. Speed	Bishops Code
66252841615	A36S-BF41	305 x 3.8 x 25.4mm	5,100rpm	65011210
66252841617	A36S-BF41	356 x 3.0 x 25.4mm	4,400rpm	65011220
66252841618	A36S-BF41	406 x 3.0 x 25.4mm	3,850rpm	65011225

GRINDING WHEELS

- Suitable for drills and tool steel
- Aluminium oxide
- White



Diameter	Thickness	Bore	Max. Speed	Grit	Bishops Code
125mm	40mm	31.75mm	3,820rpm	WA60 KV	65032010
150mm	13mm	31.75mm	3,820rpm	WA60 KV	65032060
205mm	25mm	31.75mm	3,820rpm	WA46 KV	65026120
205mm	25mm	31.75mm	3,820rpm	WA60 KV	65026140

GRINDING WHEELS

- General purpose
- Grey



Diameter	Thickness	Bore	Max. Speed	Grit	Bishops Code
152mm	20mm	25.4mm	4,460rpm	A46 Medium	65024020
152mm	25mm	25.4mm	4,460rpm	A46 Medium	65024060
200mm	25mm	25.4mm	3,340rpm	A46 Medium	65024120
250mm	25mm	25.4mm	3,340rpm	A36M Medium	65024210
200mm	40mm	38.1mm	3,340rpm	A36 Coarse	65024150
152mm	20mm	25.4mm	4,460rpm	A60 Fine	65024030
200mm	25mm	25.4mm	3,340rpm	A60 Fine	65024130

ALUMINIUM OXIDE GRINDING WHEELS



- General purpose suitable for grinding most types of steel and soft iron
- Comes with a multiple bush to assist with mounting
- Grey colour with vitrified bond



Item Code	Grade	Dia x Thick x Bore	Max. Speed	Bishops Code
66253130865	A46MVBE	150 x 20 x 25.4mm	4,140rpm	65024005
66253130583	A60MVBE	150 x 20 x 31.75mm	4,200rpm	65024006
66253130539	A36PVBE	152 x 20 x 25.4mm	4,460rpm	65024010
66253130429	A36PVBE	200 x 25 x 25.4mm	3,340rpm	65024110

SILICON CARBIDE GRINDING WHEEL

- Suitable for tungsten carbide
- 35m/s
- Diameter: 200mm
- Thickness: 25mm
- Bore: 25.4mm
- Max. speed: 3,340rpm
- Grit: 80
- Green



Diameter	Bishops Code
200mm	65026540

GREEN SILICON CARBIDE GRINDING WHEELS



- Sharp, green silicon carbide performance applications on carbide tooling and non-ferrous materials
- Vitrified bonded for superb shape holding and resistance to wear
- Speed rated for standard RPM bench and pedestal grinders
- For tungsten carbide
- Type 1



Item Code	Specification	Size	Max. Speed	Bishops Code
69083141538	39C60JVK	150 x 20.0 x 31.75mm	4,200rpm	65026510
66243545476	39C60KVKPL	200 x 25.0 x 25.4mm	3,150rpm	65026520

MOUNTED POINTS

- Primarily suited to foundry, steel mill, general engineering and stone industry applications
- Designed for rapid stock removal
- Recommended speed range: 30–50m/sec
- Shank size: 6.35mm



Shape	Grit	Bond	Bishops Code	Shape	Grit	Bond	Bishops Code
A22	60	Resinoid	65038060	A37	60	Resinoid	65038110
A23	60	Resinoid	65038065	-	-	-	-

GET MORE AT BISHOPS



BENCH GRINDERS

Page 139

5 PIECE MOUNTED POINT SETS

- Grinder stone sets suitable for die grinders
- Chrome Corundum heads
- Suitable for light to medium grinding



Item Code	Description	Bishops Code
QB-9211	1/8" Shank Mounted Point Set – Cylindrical Heads	65038800
QB-9213	1/8" Shank Mounted Point Set – Assorted Heads	65038805

VITRIFIED MOUNTED POINTS



- Primarily suited to foundry, steel mill, general engineering and stone industry applications
- Designed for rapid stock removal
- Recommended speed range: 25–50m/sec
- Shank size: 6.35mm



Item Code	Shape	Grit	Bishops Code	Item Code	Shape	Grit	Bishops Code
61463624375	A1	60	65038005	66253183099	A21	60	65038055
66253183154	A2	46	65038010	66253183100	A24	60	65038070
61463624378	A3	60	65038015	66253183101	A25	60	65038075
66253183094	A4	46	65038020	66253183102	A26	60	65038080
66253183095	A5	46	65038025	66253183103	A31	60	65038085
61463624385	A11	60	65038030	66253183105	A36	60	65038105
66253183096	A12	60	65038035	66253183106	A38	60	65038115
66253183097	A13	60	65038040	66253183107	A39	60	65038120
66253291536	A14	60	65038045	61463624544	W200	60	65038722
66253183098	A15	60	65038050	66253183139	W252	60	65038740

FLAP WHEELS

- An abrasive mop that can be attached to hand-held machines
- Suitable for profiled workpieces, inner surfaces, bottlenecks and hard to reach areas



Shaft	Size	Grit	Bishops Code
1/8"	40 x 10mm	60 Medium	65570020
1/8"	40 x 10mm	120 Fine	65570040
1/4"	60 x 15mm	80 Medium-Fine	65570130
1/4"	60 x 30mm	60 Medium	65570220
1/4"	60 x 30mm	80 Medium-Fine	65570230
1/4"	60 x 30mm	120 Fine	65570240
1/4"	60 x 30mm	240 Fine	65570250
1/4"	60 x 50mm	60 Medium	65570320
1/4"	60 x 50mm	80 Medium-Fine	65570330
1/4"	80 x 30mm	60 Medium	65570420
1/4"	80 x 30mm	80 Medium-Fine	65570430
1/4"	80 x 30mm	120 Fine	65570440
1/4"	80 x 50mm	60 Medium	65570520
1/4"	80 x 50mm	80 Medium-Fine	65570530
1/4"	80 x 50mm	120 Fine	65570540
1/4"	80 x 50mm	320 Extra Fine	65570560



FIBRE DISC BREAKDOWN

Fibre backed discs are circular discs made of fibre with one resin and abrasive coated side. These discs are made for grinding on a variety of different materials. All fibre backed discs require a backing pad to operate, so be sure to see what fits before you buy.

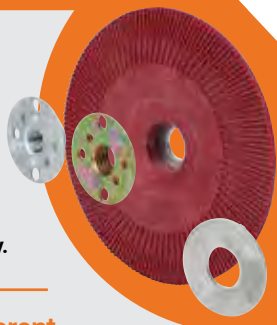

Much like other abrasives, different coating materials are best suited for different jobs. Let's recap how each abrasive performs.

Aluminium Oxide is best suited for grinding carbon steel, alloy steel, high speed steel, annealed malleable iron, wrought iron and bronzes.

Ceramic Oxide fractures at a controlled rate at the sub-micron level and is best suited for demanding applications on steel and alloys.

Zirconia Alumina is tough and durable, best suited for a broad range of steels and steel alloys.

Quick Mounting

Some fibre discs feature mounting points which allow for much faster disc changes, allowing improved productivity in grinding applications. These discs however are not universal and will only be able to be mounted on the accompanying backing pad, so be sure to check manufacturer specifications before using them.



RUBBER BACKING PADS

- For fibre discs



Diameter	Thread	Bishops Code
100mm	M10 x 1.25mm	76005010
100mm	M10 x 1.5mm	76005020
115mm	M14 x 2.0mm	76005040
125mm	M14 x 2.0mm	76005060

FIBRE DISCS

- Sanding disc suitable for use on metal surfaces
- 25 per pack



Diameter	Bore	Grit	Bishops Code
100mm	16mm	AA16	65510010
100mm	16mm	AA24	65510020
100mm	16mm	AA36	65510030
100mm	16mm	AA60	65510050
100mm	16mm	AA100	65510070
100mm	16mm	AA120	65510080
125mm	22mm	AA16	65510310
125mm	22mm	AA24	65510320
125mm	22mm	AA36	65510330
125mm	22mm	AA60	65510350
125mm	22mm	AA100	65510370
125mm	22mm	AA120	65510380
178mm	22mm	AA16	65510510
178mm	22mm	AA24	65510520
178mm	22mm	AA36	65510530
178mm	22mm	AA60	65510550
178mm	22mm	AA100	65510570
178mm	22mm	AA120	65510580

EXPERT C470 DELTA SANDPAPER



- Fast sanding of paint and wood
- 6 hole perforation
- Sheet dimensions: 93 x 93mm
- Suits Delta sanders



Item Code	Description	Grit	Pack Qty
2608900832	Delta Sandpaper Set	60/120/240	6
2608900825	Delta Sandpaper	80	5
2608900827	Delta Sandpaper	120	5
2608900829	Delta Sandpaper	240	5

SPECIAL ORDER: PLEASE QUOTE ITEM CODE UPON ORDERING THIS PRODUCT

EXPERT C470 DELTA SANDING PAPER



- Delta style sanding paper
- 11 hole perforation
- Sheet dimensions: 100 x 140mm
- 10 per pack



Item Code	Grit
2608608330	120
2608608331	240
2608608329	80
2608608328	40

SPECIAL ORDER: PLEASE QUOTE ITEM CODE UPON ORDERING THIS PRODUCT

EXPERT AVZ 32 RT10 SANDING FINGER



- Effectively sands in tight gaps
- Bosch Carbide Technology for durability
- Easy to clean and maintain
- Starlock mount for optimum power transfer and convenient blade change



Item Code	Working Width	Working Depth
2608900039	32mm	50mm

SPECIAL ORDER: PLEASE QUOTE ITEM CODE UPON ORDERING THIS PRODUCT

EXPERT AVZ 90 SANDING PLATES



- Bosch Carbide Technology for durability and long life
- Delta shape reaches into corners
- Starlock mount for optimum power transfer and convenient blade change

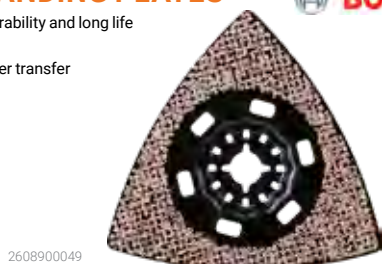

2608900049

Item Code	Description	Diameter	Grit
2608900045	AVZ 90 RT2	90mm	20
2608900047	AVZ 90 RT4	90mm	40
2608900049	AVZ 90 RT6	90mm	60
2608900043	AVZ 90 RT10	90mm	100

SPECIAL ORDER: PLEASE QUOTE ITEM CODE UPON ORDERING THIS PRODUCT

EXPERT 3 MAX AVZ 70 RT4 GROUTING PLATE



- Versatile multipurpose accessory
- Reaches into corners with its pointed tip
- Starlock mount for optimum power transfer and convenient blade change



Item Code	Diameter	Cutting Width
2608900041	70mm	2.5m

SPECIAL ORDER: PLEASE QUOTE ITEM CODE UPON ORDERING THIS PRODUCT

GRINDING DISC OR FLAP DISC?

When choosing between a grinding disc or a flap disc, it is important to first decide what is most important to you; time, finish or money?

Flap Discs, typically made from Zirconia, are generally gentler on surfaces, leaving a much smoother finish. This reduces the time needed to prepare the surface for finish or paint. However, these discs typically come at a higher cost.

Grinding Discs/Wheels are economical and good for removing material, but do not leave a smooth finish.

GET MORE AT BISHOPS



HALF-FACE RESPIRATORS

Page 21

ZIRCONIA FLAP DISCS



- Flexovit Megaline Blue HD R860 flap discs offer a high-end zirconia solution designed to reduce process costs through more aggressive cutting, improved quality, longer life and higher material removal
- Aggressive zirconia grain for high initial cut
- Strong polyester cloth and reinforced fibreglass backing for excellent product life and more material removal per disc
- Lower disc wear allows longer grinding time without loss of cut throughout disc life
- Fewer disc changes saves the end user time and money, reduces waste and reduces CO2 emissions in transportation



Item Code	Dia. x Bore	Grit	Max. Speed	Bishops Code
78072761187	100 x 16mm	C40	15,300rpm	65575020
78072761188	100 x 16mm	C60	15,300rpm	65575030
78072761192	100 x 16mm	C80	15,300rpm	65575040
78072761274	100 x 16mm	C120	15,300rpm	65575050
78072761220	125 x 22.2mm	C40	12,250rpm	65575320
78072761221	125 x 22.2mm	C60	12,250rpm	65575340
78072761222	125 x 22.2mm	C80	12,250rpm	65575341
78072761277	125 x 22.2mm	C120	12,250rpm	65575342

BLAZE RAPID CERAMIC STRIP DISCS



- Norton Blaze RapidStrip is ideal for fast stripping and cleaning without gouging or causing excessive stock removal on metal
- Depressed centre and Quick-Change discs are available and can withstand heavy applications such as stripping rust encrusted metal, without shedding
- Not only tough, Blaze RapidStrip discs are also extremely versatile, by using a lighter pressure Blaze RapidStrip can also be used as a surface finishing disc
- Heavy coating of Norton SG Blaze ceramic alumina grain delivering up to twice the life of equivalent products]Does not shed on rust-encrusted pieces or load on soft material
- Lighter pressure will deliver a finish similar to that of a medium grit surface conditioning disc and additional pressure will remove material, strip and clean



Item Code	Dia. x Bore	Max. Speed	Bishops Code
63642509505	100 x 16mm	15,000rpm	65575650
66623303783	115 x 22mm	12,000rpm	65575655
66623303916	125 x 22mm	12,000rpm	65575660
66623303920	180 x 22mm	8,000rpm	65575665

VORTEX RAPID FINISHING DISC



- Designed to dramatically reduce process times
- With its high density 3D microstructure, aggregate grain, Vortex Rapid Blend can do the job of a flap disc, surface conditioning disc and polishing disc in just one step on light welds
- High performance engineered grain for aggressive, fast stock removal, reduced cycle times and increased part quality
- Thick nylon web enables longer life and more parts per disc, resists loading
- No need to change power tools, ideal for TIG weld removal can be used in place of, or in sequence with, fibre and flap discs for improved part quality



Item Code	Dia. x Bore	Bishops Code
66254429268	115 x 22mm	65575600



WIRE BRUSHES & WHEELS

4 ROW WIRE HAND BRUSH

- Plastic handle is impervious to most oils, thinners and brake fluids
- Ideal for use in mechanical workshops



Bishops Code
76060020

WIRE HAND BRUSHES

- Ideal for cleaning and preparing surfaces where a manual application is needed
- Removal of rust, paint and slag
- Wooden handle
- 4 rows of bristles



Description	Bishops Code
Hi-Tensile Steel Bristles	76060060
Stainless Steel Bristles	76060080

CRIMPED WIRE WHEEL BRUSHES

- Brass wire construction for carbon-free brushing
- Heavy duty
- Suitable for most bench and pedestal grinders
- Rust and light paint removal
- 30gge



Diameter	Width	Bore	Max. Speed	Bishops Code
100mm	12.7mm	1/2"	4,500rpm	76065020
125mm	20mm	5/8"-1/2"	6,000rpm	76065040
150mm	20mm	5/8"-1/2"	6,000rpm	76065050
200mm	22mm	1"-5/8"	4,500rpm	76065070
250mm	28mm	1"-5/8"	3,000rpm	76065090
300mm	30mm	1"-5/8"	3,000rpm	76065094

3 PIECE CRIMPED WIRE WHEEL BRUSH SET

- Brass wire construction for carbon free brushing
- Max. speed: 4,500rpm
- Includes:**
 - 1 x 50mm cup brush
 - 1 x 50mm wheel brush
 - 1 x 25mm end brush



Bishops Code
76065095

WHAT TO USE TWIST KNOT OR CRIMPED WIRE?

In order to choose the right wire brush for the job, you must look at how rough the surface is and how aggressive the action must be to get the job done.

Crimped Wire Brushes feature loose hanging wires that allow for a lighter action compared to twist knot cup brushes. These brushes are most suited for light duty cleaning applications.

Twist Knot Brushes feature braided metal wires that produce a much more aggressive action compared to crimped wire cup brushes. These brushes are most suited for heavy duty jobs.

STAINLESS STEEL TWIST KNOT BEVEL WIRE BRUSHES

- Designed for use on stainless steel and aluminium
- Suitable for rust and paint removal
- Cleaning and deburring
- Surface preparation and conditioning
- Single row
- Wire size: 0.50mm



Diameter	No. of Knots	Gauge	Bore	Max. Speed	Bishops Code
100mm	18	25gge	10 x 1.5mm	12,500rpm	76070450
125mm	20	25gge	14 x 2mm	10,000rpm	76070860

CRIMPED WIRE CUP BRUSHES

- Ideal for cleaning and polishing
- Removal of flash, rust and paint
- Pipe, carbon and weld cleaning
- Deburring
- Wire size: 0.30mm



Diameter	Gauge	Bore	Max. Speed	Bishops Code
75mm	30gge	10 x 1.25mm	12,500rpm	76070020
75mm	30gge	10 x 1.5mm	12,500rpm	76070030
75mm	30gge	14 x 2mm	12,500rpm	76070040
100mm	30gge	14 x 2mm	8,500rpm	76070080
125mm	30gge	14 x 2mm	6,000rpm	76070100

WELDING & ABRASIVES

STAINLESS STEEL CRIMPED WIRE CUP BRUSHES

- Designed for use on stainless steel and aluminium
- Ideal for polishing and cleaning
- Removal of flash, rust and paint
- Pipe, carbon and weld cleaning
- Deburring



Diameter	Gauge	Bore	Max. Speed	Bishops Code
75mm	30gge	10 x 1.25mm	12,500rpm	76070210
75mm	30gge	10 x 1.5mm	12,500rpm	76070214

TWIST KNOT WIRE CUP BRUSHES

- Suitable for cleaning large surfaces, rust removal and deburring
- Can be used with power tools
- Wire size: 0.50mm



Diameter	No. of Rows	Gauge	Bore	Max. Speed	Bishops Code
75mm	1	25gge	10 x 1.25mm	11,000rpm	76070320
75mm	1	25gge	10 x 1.5mm	11,000rpm	76070330
75mm	1	25gge	14 x 2mm	11,000rpm	76070340
100mm	1	25gge	14 x 2mm	8,500rpm	76070360
100mm	2 with Skirt	25gge	14 x 2mm	6,000rpm	76070370
125mm	1	25gge	14 x 2mm	9,000rpm	76070380

STAINLESS STEEL TWIST KNOT WIRE CUP BRUSHES

- Designed for use on stainless steel and aluminium
- Ideal for cleaning welds and removal of paint
- Wire size: 0.50mm



Diameter	No. of Rows	Gauge	Bore	Max. Speed	Bishops Code
75mm	1	25gge	10 x 1.25mm	11,000rpm	76070410
75mm	1	25gge	10 x 1.5mm	11,000rpm	76070414
125mm	1	25gge	14 x 2mm	6,500rpm	76070430

EMERY CLOTH SHEET

- Suitable for hand grinding of all types of materials
- Sheet size: 230 x 280mm
- Sold per sheet

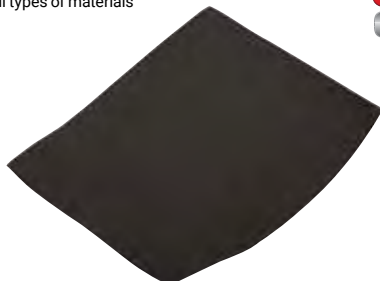

Grit	Bishops Code	Grit	Bishops Code
80g	65530030	180g	65530070
120g	65530050	240g	65530090

WATERPROOF SANDING PAPER

- Waterproof abrasive paper
- Non-loading
- Aluminium oxide
- Sheet size: 230 x 280mm
- Sold per sheet



Grit	Bishops Code	Grit	Bishops Code
60g	65520020	180g	65520070
80g	65520030	240g	65520090
100g	65520040	400g	65520120

SILICON CARBIDE WET & DRY SHEET

- Suitable for wet and dry sanding of metal or painted surfaces
- Sheet size: 230 x 280mm
- Sold per sheet



Grit	Bishops Code	Grit	Bishops Code
60g	65525020	320g	65525110
80g	65525030	360g	65525120
100g	65525040	400g	65525130
120g	65525050	500g	65525140
150g	65525060	600g	65525150
180g	65525070	800g	65525160
220g	65525080	1,000g	65525170
240g	65525090	1,200g	65525180
280g	65525100	-	-

METALITE EMERY CLOTH ROLLS

- Cloth rolls are typically used for polishing lathe turnings, rolls and cylinders, light deburring, blending machine tool marks, removing rust and scale, and fine sanding and polishing
- P-graded aluminum oxide abrasive grain for fast cut rate and consistent finish on metals
- Flexible J-wt. backing for superior conformability to complex surfaces and better finishes
- Cloth rolls are packaged in a protective, convenient dispenser which eliminates costly waste and permits neat, easy storage



25MM X 50M			50MM X 50M		
Item Code	Grit	Bishops Code	Item Code	Grit	Bishops Code
66623320795	P60	65550020	66623320796	P60	65550520
66623320801	P80	65550030	66623320802	P80	65550530
66623320811	P120	65550050	66623320805	P100	65550540
66623320821	P180	65550070	66623320809	P120	65550550
66623320818	P240	65550090	66623320819	P180	65550570
66623320815	P320	65550110	66623320817	P240	65550590
-	-	-	66623320813	P320	65550600



SANDING ROLLS, BELTS & ACCESSORIES & WHEEL DRESSERS

FLOOR PAPER ROLL

- Width: 300mm
- 50m roll



Grit	Bishops Code
40g	65560120
60g	65560140
100g	65560180

SANDING BELTS

- Abrasive cloth suitable for wood working and metal applications



Size	Grit	Bishops Code	Size	Grit	Bishops Code
75 x 533mm	40g	65540020	75 x 1,180mm	80g	65540180
75 x 533mm	60g	65540030	75 x 1,180mm	120g	65540190
75 x 533mm	80g	65540040	75 x 2,000mm	60g	65540200
75 x 533mm	120g	65540060	75 x 2,000mm	80g	65540210
75 x 610mm	40g	65540120	100 x 560mm	80g	65540240
75 x 610mm	60g	65540130	100 x 560mm	100g	65540250
75 x 610mm	80g	65540140	150 x 2,000mm	40g	65540870
75 x 610mm	120g	65540160	150 x 2,000mm	60g	65540872
75 x 610mm	150g	65540165	150 x 2,000mm	80g	65540874
75 x 1,180mm	60g	65540170	150 x 2,000mm	120g	65540876

SANDING BELTS

- Advanced full resin bond system for exceptional grain adhesion and longer life
- Applications include weld removal and the finishing of ferrous and nonferrous materials
- Strong cloth backing provides a multi-purpose product ideal for sanding wood and grinding metal



50 X 915MM			100 X 610MM		
Item Code	Grit	Bishops Code	Item Code	Grit	Bishops Code
66623321297	40g	65540720	66623381797	40g	65540320
66623321298	60g	65540740	66623381807	60g	65540330
66623321299	80g	65540760	66623381818	80g	65540340
66623321184	120g	65540780	66623381824	100g	65540350
-	-	-	66623381835	120g	65540360

HAWK 900 SANDING BLOCK

- Accepts sand paper approx. 210 x 70mm
- Block size: 130 x 70mm



Item Code	Bishops Code
000-3008	65599990

WHEEL DRESSERS

- Accurately and easily reconditions grinding wheels to their original shape
- Rugged cast handle
- Corrugated high quality hardened steel cutters
- Spare wheels readily available



Item Code	Description	Weight	Bishops Code
62204	Wheel Dresser No. 0	800g	65094520
62205	Wheel Dresser No. 1	1.2kg	65094540

Item Code	Description	Size	Bishops Code
67188	Spare Wheel No. 0	6.7(ID) x 30.7(OD)mm	65094570
67189	Spare Wheel No. 1	13(ID) x 38.5(OD)mm	65094580

WHEEL DRESSER & STAR CUTTERS

- Designed for dressing, truing, sharpening and removing glaze from solid abrasive wheels
- Powder coated finish on body
- Cast iron handle is ergonomically designed for comfortable grip
- The cutters have star shaped teeth that expose new grains and provide a fresh unloaded surface on wheels
- Dresser wheel range: 500mm
- Dresser length: 255mm
- Cutter diameter: 32mm
- Spare cutters available



Item Code	Description	Bishops Code
WD/00	Wheel Dresser - Size 0	65094020
WDC/00	Replacement Star Cutters - Size 0	65094040

KNOW YOUR GRADES

Not all belts are defined by their grit, some are better explained with their grade. To give you a better idea of what each grade means, this is how they are defined by ISO 6344.

Extra Coarse grades include 12, 16, 20, 24, 30 & 36 grit.

Coarse grades include 40 & 50 grit.

Medium grades include 60 & 80 grit.

Fine grades include 100 & 120 grit.

Very Fine grades include 150, 180, 220, 240, 280, 320 & 360 grit.

Super Fine grades include 800, 1,000 & 1,200 grit.

HOW TO CHOOSE A SHARPENING STONE

Aluminium Oxide

Aluminium oxide stones are durable and smooth cutting. They create a fine edge on blades and tools. Orange or brown in colour, aluminium oxide must be used with a lubricant.

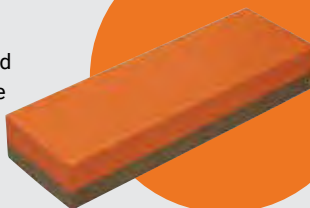

Silicon Carbide

Silicon carbide stones sharpen faster but with less fineness. Dark grey in colour, they are a good option for time critical sharpening. Silicon carbide must be used with a lubricant.

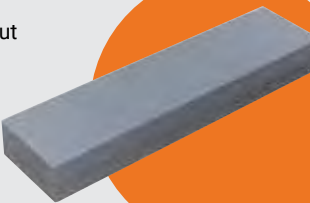

Diamond Stone

Diamond stones are high quality sharpening utensils, delivering fast blade sharpening. Unlike other sharpening stones they can be used with or without a lubricant. Even though diamond stones are the most expensive, they are long lasting and in the long term may be cost comparable.

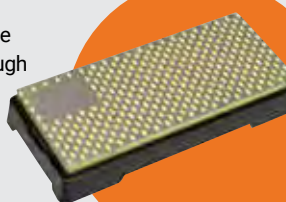

Oil Filled or Non-Oil

Aluminium oxide and silicon carbide sharpening stones can be purchased oil filled or without oil. Oil filled stones have been treated with lubricant in factory, making them ready for use. Non oil stones have not undergone this treatment and need to be lubricant soaked before use. For best practice, always re-lubricate your stone before use no matter the type.

SHARPENING BENCH STONE

- Combination stone with coarse finish on one side and a fine finish on the other side
- 200(l) x 50(w) x 25(h)mm

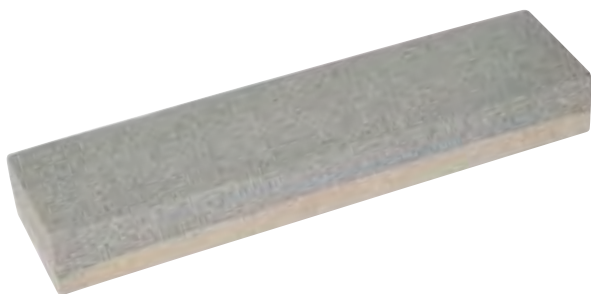

CHOOSING YOUR SANDBLASTING MEDIUM

When it comes to sandblasting, a wide variety of different bead sizes and materials are available for use. In order to help you decide, Bishops has created this easy reference guide for you to compare sizes of grit.

Abrasive Size Conversion Chart

Grit Size (Microns)			Microns	Reference
Minimum	Maximum	Grit Equivalent		
1,400	2,300	10	841	Granulated Sugar
660	1,350	20		
360	815	30	595	Coffee
240	560	45		
165	400	60	400	Black Pepper
100	300	80		
60	200	100	297	Table Salt
50	165	120		
40	140	150	250	Powdered Sugar
25	115	180		
20	100	220	210	Human Hair
25	85	240		
9	70	280	177	
14	60	320		
11	45	400	149	
9	35	600		
2	23	1,000	125	
			105	
			88	

*Not to scale

Bead Hardness

Whilst grit makes a big difference in sandblasting applications, so does the material you choose. Different materials will give you different finishes and some can even speed up the time taken to remove the surface of your working material.

Soft Abrasives such as walnut and plastic have little ability to indent the underlying surface of your sandblasting material. These abrasives are mostly used for removing the surface of soft materials where you do not want to damage the underlying surface.



Medium Abrasives such as glass and sand are suitable for removing the top layer of a surface and often leave a smooth finish behind. These abrasives are used for general purpose sandblasting and will suit most applications.



Hard Abrasives such as garnet are suitable for removing the top layer of hard surfaces. Due to their hardness and often rigid finish, these beads will heavily mark softer surfaces and are not suitable for finishing applications.



Can't find what you're looking for?

Bishops is able to supply all the little things you need, even sandblasting abrasives, so give us a call and we'll help you out!

Item Code
5760314

Bishops Code
65036060





04

POWER, PNEUMATIC & ENGINE POWERED TOOLS

CORDLESS POWER TOOLS

Cordless Tool Kits.....	134–136
Angle Grinder.....	136
Screwdriver.....	136
Impact Wrench.....	136
Planers, Sanders & Polishers.....	136–137
Tool Batteries & Chargers.....	137

ELECTRIC POWER TOOLS

Angle & Die Grinders.....	138–139
Bench Grinders & Linishers.....	139
Impact & Rotary Hammer Drills.....	140
Demolition Hammers.....	140
Magnetic Base Drills.....	141
Drill Presses.....	141
Circular & Cut-Off Saws.....	142
Mitre & Table Saws & Stands.....	142–143
Jigsaws, Router & Nibblers.....	143
Oscillating Multi-Tool & Attachments.....	143–144
Heat Gun.....	144
Rebar Cutters & Bender/Straighteners.....	144
Planers, Sanders & Polishers.....	144–145

PNEUMATIC POWER TOOLS

Angle & Die Grinders & Kits.....	146
Hand Drills.....	147
Impact & Ratchet Wrenches.....	147–148
Shears & Needle Scalers.....	149
Hammer Chisels.....	150
Orbital Sanders.....	150
Riveters & Engravers.....	150
Blow Guns & Cleaning Guns.....	150

ENGINE POWER TOOLS

Earth Auger Drill.....	152
Cut-Off Saws.....	152
Chainsaws & Saw Mills.....	152–153
Hedge Trimmer & Pruners.....	153
Brushcutters & Grass Trimmers.....	154
Lawnmowers.....	155
Leaf Blower.....	155



BISHOPS' TOOL GLOSSARY: POWER TOOLS

How They're Powered

CORDLESS

Cordless/Battery Operated

Cordless tools are operated by battery. Removing the cord eliminates the tools reliance on a power point and increases its portability. Batteries do need to be recharged frequently and replaced periodically. If you do not have a spare battery, a dead battery will leave you in the lurch.

ELECTRIC

Electric/Corded

Corded tools are not limited by their battery life and will operate whenever they are plugged into a power point. They provide consistent and reliable torque, powered by the constant flow of electricity. Corded tools often last longer than cordless tools.

PNEUMATIC

Pneumatic

Pneumatic tools are driven by compressed air from an air compressor. As they don't have a battery on board they tend to be lighter than electric or battery operated tools. As there is no working electrical motor, a pneumatic tool can be run constantly, with the use of a filter regulator lubricator, without having to break to cool the motor.

ENGINE

Petrol/Diesel

Engine powered tools are engineered with two or four-cycle engines, making them much more powerful than their electric counterparts, while still providing the convenience of being cordless. This makes them suitable for industrial applications such as concrete cutting. Like your car, petrol and diesel engine operated tools require regular maintenance to ensure that they run smoothly.

THIS SECTION IS LAID OUT BY HOW THE TOOL IS POWERED.

Get the job done right every time using the best tool possible!

Whether you are on the tools every day, or just need one handy for odd jobs – we have the tool for you. We want to make the process of choosing the right tool as easy as possible. This glossary simply explains the uses for some common tools and what attributes you should be looking for when considering your usage. Need more assistance? Give one of our knowledgeable team members a call!

Angle Grinders **CORDLESS** **ELECTRIC** **PNEUMATIC**

They are the masters of cutting and grinding metal or stone. They work by spinning an abrasive disc at high speeds (anywhere from 8,000rpm to 12,000rpm). When purchasing an angle grinder, the first thing to check is the disc diameter. The disc diameter determines what size cutting or grinding disc is compatible with the grinder. Generally, the larger the disc diameter the more power the grinder has. 'No load speed' indicates how quickly the disc spins when no load is applied. The optimal speed changes depending on the application; the faster the disc, the more heat created, along with increased cutting capacity. A slower moving disc doesn't generate as much heat and is recommended for applications such as polishing.

Die Grinders **ELECTRIC** **PNEUMATIC**

Small, lightweight hand held grinders are used for grinding, sanding, honing and polishing metal. Their size makes them ideal for fine detail work in tight spaces. They typically have a high 'no load speed' but low torque. Mounted points or carbide burs are attached to the die grinder by a collet. Carbide burs come in a range of shapes and sizes to suit any application. See the Hand & Cutting Tools section for Bishops' range of carbide burs. When choosing a die grinder, consider the 'no load speed'. The higher the speed, the faster the die grinder will cut.

Impact Drivers **CORDLESS**

Short and stubby in their appearance, they are ideal for driving in fasteners. During light duty applications the driver will behave like a cordless screwdriver. Once the driver hits opposing torque it applies a series of rapid rotary impulses which deliver a substantial amount of torque to assist driving the fastener. This adaptive design reduces the likelihood of over-torqued, stripped or damaged fasteners. Look for an impact driver with high power. The additional power will make light work of jobs too difficult for standard electric drivers and may actually be easier on the wrist than other drilling options.

Hammer Drills – Impact **CORDLESS** **ELECTRIC**

Hammer drills contain more power than an average impact drill. As well as the rotating action, a hammer drill also delivers rapid perpendicular blows, ideal for drilling into masonry and rock. It has an adjustable clutch mechanism to match power output to the application and fastener size. This prevents fasteners from being over-torqued and stripped, damaged or sheared-off. 'Blows per minute' and 'impact energy' are good indicators of a quality hammer drill. The higher the impact and impact energy, the better the tool will drill, drive or chisel into masonry. Keep in mind that increased power will come at the cost of portability and weight.



BISHOPS' TOOL GLOSSARY: POWER TOOLS

Hammer Drills – Rotary **CORDLESS** **ELECTRIC**

A rotary hammer drill is powered by a piston driven crankshaft instead of a clutch. This mechanism creates more impact energy and a longer stroke. The added power makes rotary hammer drills ideal for heavy duty jobs. Most rotary hammer drills have multiple modes such as drill only, hammer drill or hammer only. Like the impact hammer drill, the impact energy is a good indicator of a high powered rotary hammer. Anything from 3 – 5J will be ideal for medium to heavy duty tasks. The revolutions per minute (rpm) measures how fast the drill is. In heavy duty applications the rpm should be over 2,000.

Magnetic Base Drills **ELECTRIC**

These portable drills are used to drill holes in a variety of metals. Their portability makes them ideal for drilling holes in large heavy workpieces. The magnet contained within the base attaches to ferrous metal surfaces. Magnetic base drills can be placed in almost any position, even upside down, to access hard to reach areas. Take into consideration where and when you will most use your magnetic base drill. Smaller, lightweight models are better for working at height and tight spaces. For drilling through thick pieces of metal, look for a model with high rpm and variable speeds.

Impact Wrenches **CORDLESS** **PNEUMATIC**

Impact wrenches are used to loosen and tighten nuts, bolts and fasteners by applying rotational force in short bursts. Because the force is released in bursts, the impact wrench is able to apply much more torque. Impact wrenches are all about torque. The higher the maximum torque, the more easily the wrench will be able to loosen or tighten. You don't need all that power for light duty jobs; for more versatility opt for a model with adjustable torque settings.

Circular Saws **ELECTRIC**

Circular saws are typically hand held and portable, and used to cut through wood, masonry, plastic or metal with minimal effort. A blade with teeth is attached to an arbor which moves at high speed in a rotary motion. Multiple blade options are available depending on the material being cut. Check out our Hand & Cutting Tools section for Bishops' range of circular saw blades. Keep an eye on your maximum cutting depth, making sure that the depth is slightly larger than the material that you are planning to cut. Also note the motor wattage and rpm. A higher motor wattage will result in a higher rpm and the ability to cut tougher materials.

Mitre Saws **ELECTRIC**

Mitre saws are much like circular saws, however the actual saw part of the mitre saw is manoeuvrable, allowing angled cuts. Mitre saws are usually small and portable but are not hand held and need to be used on a bench or the floor. Take into account the angles that the mitre saw can cut on and whether it can only be adjusted from one side or from the left and right. Models adjustable from both sides are typically easier to use. Also make sure that the depth at each angle is deep enough for the materials being cut.

Cut-Off Saws **ELECTRIC** **ENGINE**

A cut-off saw resembles the mitre saw. Like the mitre saw it is portable, but needs to be used on a bench or floor. The only distinct difference is that the cut-off saw does not manoeuvre like the mitre saw, therefore only offers cuts at a 90° angle. It does however provide a more stable means than hand held saws to secure the material on the saw while the cut is in progress. Like other saws, make sure the depth the saw provided is deep enough for the materials being cut. Again, the higher the rpm, the tougher the materials the saw will be able to power through.

Reciprocating Saws **CORDLESS**

Out of all the electric saws, the reciprocating saw most resembles the traditional manual saw by moving a thin, long toothed blade in a fast back-and-forth motion. The blade is exposed, allowing access to tight and awkward spaces where a circular saw would be impractical. Decide what is more important – usability or speed? If it is usability, go for a lightweight model with a smaller motor. If it is speed, opt for a model with a larger motor. Stroke per minute (spm) indicates how fast the saw will cut – the higher the spm, the faster the cut.

Disc Sanders **CORDLESS** **ELECTRIC** **PNEUMATIC**

Sanders are typically hand held and are used to smooth and clean surfaces using abrasive paper or pad. Choose between orbital or circular sanders. Orbital sanders work by moving rapidly in a random orbital fashion, making them ideal for smoothing curves. The higher the rpm, the faster the surface will smooth. This is not always ideal, especially in fine and detailed jobs. Make sure that the sander itself has an ergonomic design to reduce hand fatigue. Some models come with dust extraction connections to keep the worksite tidy and safe.

Belt Sanders **ELECTRIC**

Belt sanders use abrasive paper belts that are fitted to the sander. Belt sanders are typically larger than disc sanders and best used on large flat surfaces where their task is to smooth large surfaces as quickly as possible. Some models come with dust extraction connections to keep the worksite tidy and safe.



THIS IS A HANDFUL OF WHAT WE STOCK.
WE COULDN'T FIT IN OUR MASSIVE RANGE OF POWER TOOLS.

FOR MORE
CONTACT BISHOPS



CORDLESS TOOL KITS

POWER, PNEUMATIC & ENGINE POWERED TOOLS

M18 FUEL™ 125MM ANGLE GRINDER KIT

Includes:

- 1 x M18 FUEL™ 125mm Angle Grinder w. Deadman Paddle Switch (tool only)
- 2 x M18™ REDLITHIUM™-ION 5.0Ah Batteries
- 1 x M12™ & M18™ Rapid Charger



Item Code	Bishops Code
M18FAG125XPD-502C	75060280

M18™ COMPACT DRILL/DRIVER KIT

Includes:

- 1 x M18™ 13mm Compact Brushless Drill/Driver (tool only)
- 2 x M18™ REDLITHIUM™-ION 3.0Ah Batteries
- 1 x M12™ & M18™ Rapid Charger



Item Code	Bishops Code
M18CBLDD-302C	75060200

M12 FUEL™ HAMMER DRILL/DRIVER KIT

Includes:

- 1 x M12™ 13mm Hammer Drill/Driver (tool only)
- 2 x M12™ REDLITHIUM™-ION 2.0Ah Compact Batteries
- 1 x M12™ Lithium-Ion Charger



Item Code	Bishops Code
M12FPD-2202C	75060220

IMPACT DRIVERS

Impact Drivers are essentially motorised screwdrivers with an impact hammer drive to further enhance the screwing efficiency. They use a combination of bit rotation and powerful, concussive blows to deliver much more torque than your standard drill driver.

Impact Drivers are designed to drive screws, which they can do with more speed and ease than any other tool. If you're serious about driving your fasteners, consider an impact driver.

18V BRUSHLESS 13MM HAMMER DRILL KIT



- Best power-to-size ratio in Bosch's 18V category – with brushless motor and impact drilling function
- Ideal combination of power and size due to 60Nm of hard torque and a 174-mm head length
- KickBack Control for increased user protection, safer work, and perfect tool control; precision clutch for convenience
- Bluetooth Connectivity option to connect directly to a smartphone for additional tool control

Includes:

- 1 x GSB 18V-60C 18V 13mm Hammer Drill
- 1 x 4.0 Ah LI Battery
- 1 x 18V-40 Charger
- 1 x Tool Bag



Item Code	Bishops Code
0.615.990.J9U	75002270

18V BRUSHLESS 26MM HAMMER DRILL KIT



- KickBack Control and Electronic Precision Control for better tool handling and increased user protection
- Delivers 2.6J of impact energy for fast drilling and high chisel removal performance

Includes:

- 1 x GBH P 18V-26 C 18V 26mm Hammer Drill
- 1 x 4.0 Ah LI Battery
- 1 x 18V-40 Charger
- 1 x Tool Bag



Item Code	Bishops Code
0.611.909.000	75002275

M18 FUEL™ SDS PLUS ROTARY HAMMER KIT

Includes:

- 1 x M18 Fuel™ 26mm SDS Plus Rotary Hammer (tool only)
- 2 x M18™ REDLITHIUM™-ION HIGH OUTPUT™ 6.0Ah Batteries
- 1 x M12™ & M18™ Rapid Charger



Item Code	Bishops Code
M18FH-602C	75060120

M18 FUEL™ 3 PIECE POWER PACK

Includes:

- 1 x M18 FUEL™ 13mm Hammer Drill/Driver (tool only)
- 1 x M18 FUEL™ ¼" Hex Impact Driver (tool only)
- 1 x M18 FUEL™ 125mm Angle Grinder w. Deadman Paddle Switch (tool only)
- 2 x M18™ REDLITHIUM™-ION 5.0Ah Batteries
- 1 x M12™ & M18™ Rapid Charger



Item Code	Bishops Code
M18FPP3L2-502B	75060250

2 PIECE 18V BRUSHLESS COMBO KIT

Hammer Drill:

- Best power-to-size ratio in Bosch's 18V category – with brushless motor and impact drilling function
- Ideal combination of power and size due to 60Nm of hard torque and a 174mm head length
- KickBack Control for increased user protection, safer work, and perfect tool control; precision clutch for convenience
- Bluetooth Connectivity option to connect directly to a smartphone for additional tool control

Impact Driver:

- 2-in-1 tool holder with ¼" internal hex and ½" square drive guarantees flexibility for the widest range of applications
- Brushless motor with 200Nm tightening torque and 350Nm breakaway torque for excellent battery runtime and long tool lifetime
- Better control of speed and torque due to the variable speed trigger

Includes:

- 1 x GSB 18V-60C 13mm Hammer Drill
- 1 x GDX 18V-200 Impact Driver
- 2 x 4.0 Ah Battery
- 1 x 18V 4.0A Charger
- 1 x Tool Bag



Item Code	Bishops Code
0.615.991.FH5 KIT	75002260

4 PIECE 18V BRUSHLESS COMBO KIT

- Perfect combo kit containing all the brushless tools and accessories you need to get the job done

Includes:

- 1 x GSB 18-85C Hammer Drill
- 1 x GDX 18V-200 Impact Driver
- 1 x GWS 18V-10 125mm Angle Grinder
- 1 x GBH 18V-26 26mm SDS Hammer
- 2 x 5.0 Ah Battery
- 1 x 18V 5.0A Charger
- 1 x Tool Bag



Item Code	Bishops Code
0.615.990.M19	75002265

M18™ 2 PIECE POWER PACK

Includes:

- 1 x M18™ 13mm Brushless Hammer Drill/Driver (tool only)
- 1 x M18™ ¼" Hex Impact Driver (tool only)
- 1 x M18™ REDLITHIUM™-ION 4.0Ah Battery
- 1 x M12™ & M18™ Rapid Charger



Item Code	Bishops Code
M18BLPP2A2-402C	75060110

18V BRUSHLESS IMPACT WRENCH KIT

- Compact and lightweight impact wrench with adjustable modes for multi-purpose use
- Two default screw modes for multi-purpose use
- Each mode can be adjusted and individualised via the Bosch Toolbox App
- Powerful 330Nm tightening and 560Nm breakaway torque performance
- Versatile three-speed/torque settings for more flexibility and control

Includes:

- 1 x GDS 18V-330 HC 18V Brushless 330Nm Impact Wrench
- 1 x 4.0 Ah LI Battery
- 1 x 18V-40 Charger
- 1 x Tool Bag



Item Code	Bishops Code
0.601.9L5.000	75002285



CORDLESS TOOL KITS & CORDLESS TOOLS

POWER, PNEUMATIC & ENGINE POWERED TOOLS

M18 FUEL™ ½" HIGH TORQUE IMPACT WRENCH KIT

Includes:

- 1 x M18 FUEL™ ½" High Torque Impact Wrench with Friction Ring (tool only)
- 2 x M18™ REDLITHIUM™-ION 5.0Ah Batteries
- 1 x M12™ & M18™ Rapid Charger



Item Code	Bishops Code
M18FHIWF12-502C	75060290

M12 FUEL™ RECIPROCATING SAW KIT

Includes:

- 1 x M12 FUEL™ HACKZALL™ Reciprocating Saw (tool only)
- 1 x M12™ REDLITHIUM™-ION 4.0Ah Battery
- 1 x M12™ Lithium-Ion Charger



Item Code	Bishops Code
M12CHZ-401C	75060240

M12™ SPOT POLISHER/SANDER KIT

Includes:

- 1 x M12™ Spot Polisher/Detail Sander (tool only)
- 1 x 5 Piece accessory pack - 3" polishing backing pad, 2" sanding backing pad, wool pad, yellow foam pad & white foam pad
- 2 x M12™ REDLITHIUM™-ION 2.0Ah Compact Battery
- 1 x M12™ Lithium-ion Battery Charger
- 1 x Side Handle



Item Code	Bishops Code
M12BPS-202B	75060230

GWS 18V-10 CORDLESS BRUSHLESS 125MM ANGLE GRINDER



- Powerful brushless motor
- Drop Control, Kickback Control and intelligent brake system for improved user safety and convenience
- Equivalent power to a 1,000W corded angle grinder
- No load speed: 9,000rpm
- Disc diameter: 125mm
- Spindle thread: M14
- Weight (excl. battery): 2.1kg
- Battery not included



Item Code	Bishops Code
0.601.9J4.002	75002280

GTB 18V-45 PROFESSIONAL CORDLESS DRYWALL SCREWDRIVER



- Comes with PowerSAVE mode, brushless motor, and retractable depth stop, offering maximum ease of use
- For a silent job, the motor will be activated automatically as soon as the screw touches the wall when PowerSAVE mode is switched on
- Significantly extends the runtime and increases the number of screws per battery charge, compared to a switched off PowerSAVE mode
- Retractable depth stop eliminates the need to remove the depth stop for unscrewing the screws by keeping depth setting unchanged
- Max. torque: 6Nm
- No-load speed: 0–4,500rpm
- Weight excl. battery: 0.95kg
- Battery not included



Item Code	Bishops Code
0.601.9K7.005	
SPECIAL ORDER: PLEASE QUOTE ITEM CODE UPON ORDERING THIS PRODUCT	

GDS 18V-1000 C ½" CORDLESS IMPACT WRENCH



- Powerful ½" cordless impact wrench with adjustable modes
- BITURBO Brushless technology providing 1,000Nm tightening torque and 1,600 breakaway torque
- User interface with two default modes, metal (A) and wood (B)
- Additional modes can be adjusted and individualised via the Toolbox App
- More flexibility and control via three speed/torque settings
- Voltage: 18V
- Max. torque: 1,000Nm
- No-load speed: 1,750 rpm
- Weight excl. battery: 2.9kg



Item Code	Bishops Code
0.601.9J8.000	75002540

GHO 18V-LI CORDLESS PLANER



- Delivers impressive performance in the 18V category.
- Continuously adjustable depth-of-cutting setting of up to 1.6mm, enabling fast, uninterrupted work progress
- Fitted with ultra-sharp and durable carbide reversible blades, producing high-quality, accurate surface results
- Lightweight design ensures easy, comfortable handling
- Dual ejection system, motor brake, ECP
- No-load speed: 14,000rpm
- Planing depth: 1.6mm
- Rebating depth: 0–8mm
- Planing width: 82mm
- Weight excl. battery: 1.5kg



Item Code	Bishops Code
0.601.5A0.307	
SPECIAL ORDER: PLEASE QUOTE ITEM CODE UPON ORDERING THIS PRODUCT	

GET MORE AT BISHOPS



SANDING PADS

Page 127

GSS 18V-13 18V BRUSHLESS ORBITAL SANDER



- Optimal control through superior ergonomics and excellent tool balance
- Fast work progress thanks to brushless motor and Bosch's Professional 18V system
- Intuitive operation with three interchangeable sanding plates
- 1/3 sheet (80x130)
- 1/4 sheet (100x110)
- Delta Pad
- 3 x sanding paper
- No-load orbital stroke rate: 12,000–20,000opm
- No load speed: 6,000–10,000rpm
- 1.6mm orbit diameter
- Variable speed motor



Item Code

06019L0140

SPECIAL ORDER: PLEASE QUOTE ITEM CODE UPON ORDERING THIS PRODUCT

GEX 18V-125 18V BRUSHLESS 125MM RANDOM ORBITAL SANDER



- Outstanding balance close to the workpiece and supreme ergonomics of palm rest and grip offer optimal tool control
- Brushless motor and Bosch's Professional 18V system ensure fast work progress and high endurance
- Easy and intuitive operation
- Sanding pad diameter: 125mm
- No-load speed: 6,000–10,000rpm
- Orbital stroke rate: 12,000–20,000opm
- Orbital diameter: 2.5mm
- Dust bag included
- Weight: 1.1kg



Item Code

0.601.372.241

SPECIAL ORDER: PLEASE QUOTE ITEM CODE UPON ORDERING THIS PRODUCT

M18™ 125MM CORDLESS ORBITAL SANDER

- Variable speed control
- Overload protection
- Pad size: 125mm
- Oscillating speed: 12,000opm
- Tool only, battery sold separately



Item Code

M18BOS125-0

Bishops Code

75060380

GBA 18V 4.0AH PROFESSIONAL BATTERY



- 4.0Ah battery with extended runtime in the 18V category
- Delivers 100% more runtime than the 18V 2.0Ah model due to its higher battery capacity
- COOLPACK 1.0 improves heat dissipation from the inside to the outside of the battery for longer lifetime and runtime
- Compatible with all tools and chargers of the Bosch Professional 18V System and the AMPShare Alliance
- Charge level indicator
- 80(w) x 100(l) x 150(h)mm
- Weight: 0.6kg



Item Code

1.600.A00.163

Bishops Code

75016054

M12™ & M18™ CORDLESS TOOL BATTERIES

- Batteries to suit M12 and M18 range of cordless tools



Item Code	Description	Capacity	Bishops Code
M18HB3	M18™ REDLITHIUM™-ION High Output Battery	3.0Ah	75060505
M18HB6	M18™ REDLITHIUM™-ION High Output Battery	6.0Ah	75060510
M12B3	M12™ REDLITHIUM™-ION Compact Battery	3.0Ah	75060520
M12B6	M12™ REDLITHIUM™-ION Battery	6.0Ah	75060525

18V BATTERY CHARGER



- The GAL 18V-40 offers a highly compact modern design
- With its 4A charging current it charges a GBA 18V 4.0Ah battery up to 80% in only 48 minutes and a GBA 18V 2.0 Ah battery up to 80% within 24 minutes
- This compact charger is part of the Bosch Professional 18V System and is 100% compatible with all Bosch Professional 18V batteries
- Wall-mountable



Item Code

1.600.A01.9RN

Bishops Code

75016056

M12™ & M18™ RAPID BATTERY CHARGER

- Fast charging time
- Sequential charging function
- Suits all M12 and M18 batteries
- Charging level indicator



Item Code

M12-18FC

Bishops Code

75060500

CONTRACTORS POWER TOOL BAGS

- 600D water resistant fabric
- Carry handles and detachable shoulder strap
- Reinforced base
- Durable zipper closure
- Ideal for storing and transporting power tools and accessories



Item Code	Description	Size	Bishops Code
48553490	Contractor Bag	430(l) x 228(w) x 254(h)mm	75060600
48553530	Contractor Bag – X-Large	600(l) x 305(w) x 300(h)mm	75060605



ELECTRIC ANGLE GRINDERS

POWER, PNEUMATIC & ENGINE POWERED TOOLS

ANGLE GRINDERS – 750W

- 56mm diameter slim rounded housing for comfortable holding
- Dimple surface for anti-slip
- Powerful and robust 720W motor
- Specially designed air inlets for optimal air flow and cooling
- Small gear head for working in tight spaces
- Gear head can be rotated in 90° steps
- Armoured coils that protect motor against sharp grinding dust for longer service life
- Auto cut-off carbon brushes
- Two-motion switch for maximum user safety
- Spindle lock for easy disc change
- Anti-rotation protective guard to provide reliable protection
- The handle can be fitted to both the left and right sides



GWS 750-100

Item Code	Disc Dia.	No Load Speed	Spindle	Weight	Bishops Code
GWS 750-100	100mm	11,000rpm	M10 x 1.5mm	1.8kg	75010100
GWS 750-125	125mm	11,000rpm	M14 x 2mm	1.9kg	75010325

GWS 880 125MM ANGLE GRINDER – 880W

- Small angle grinder with powerful 880W motor for fast work progress
- Superior tool control due to its small grip size and ergonomic design
- Restart protection feature prevents uncontrolled starts for increased control and higher user safety
- Side switch and handle
- No-load speed: 11,000rpm
- Spindle size: M14
- Weight: 1.9kg



Item Code	Bishops Code
0.601.396.042	75010200

GWS 1400 C 125MM ANGLE GRINDER – 1,400W

- Extremely powerful 1,400W Champion motor
- Anti-rotation protective guard – quickly and easily adjustable, provides reliable protection
- Vibration Control auxiliary handle ensures your joints are protected during working
- Direct cooling for high overload capability and long lifetime
- No-load speed: 11,000rpm
- Rated input power: 1,400W
- Power output: 820W
- Spindle size: M14
- Weight: 2.2kg



Item Code	Bishops Code
0.601.824.241	75010335



GWS 15-125 CIEP 125MM ANGLE GRINDER – 1,500W

- Deadman switch turns tool off when disc is jammed
- Kickback stop
- Vibration control auxiliary handle for user health and safety
- Restart protection prevents sudden restart after loss of power
- Burst proof guard for increased user protection with tool-less adjustment
- Constant electronic for fast and efficient work even under heavy load
- The handle can be fitted to both left and right sides
- PROtection switch
- 220–240V
- Rated power input: 1,500W
- Power output: 820W
- No-load speed: 2,800–11,500rpm
- Grinding spindle thread: M14
- Disc diameter: 125mm
- Rubber sanding plate diameter: 125mm
- Wire cup brush diameter: 75mm
- Weight: 2.5kg



Item Code	Bishops Code
0.601.796.242	75010350

GWS 24-180 LVI 180MM ANGLE GRINDER – 2,400W

- High-powered 2,400W motor ensures strong results for advanced work
- User protection increased to an especially high level due to KickBack Control and restart protection
- Vibration Control main handle and Vibration Control auxiliary handle reduce vibration up to 50%
- Rated power input: 2,400W
- No-load speed: 8,500rpm
- Grinding spindle thread: M14
- Disc diameter: 180mm
- Weight: 5.4kg



Item Code	Bishops Code
0.601.892.H40	75010425

GWS 24-230 LVI 230MM ANGLE GRINDER – 2,400W

- Strong results also for advanced work are ensured by a high-powered 2,400W motor
- User protection increased to an especially high level due to KickBack Control and restart protection
- Vibration Control main handle and Vibration Control auxiliary handle reduce vibration up to 50%
- Rated power input: 2,400W
- No-load speed: 6,500rpm
- Grinding spindle thread: M14
- Disc diameter: 230mm
- Weight: 5.5kg



Item Code	Bishops Code
0.601.893.H40	75010525



GGG 28 LCE STRAIGHT DIE GRINDER – 650W



- Powerful 650W motor for fast work progress with soft start
- Extra long grinding spindle – ideal for grinding in tight spots
- KickBack stop detects when grinding stone gets jammed and shuts down the tool immediately for high user protection
- No-load speed: 10,000–28,000rpm
- Weight: 1.6kg



Item Code	Bishops Code
0.601.221.140	75010553

BENCH GRINDER – 150MM



- Powerful induction motor
- Power: 280W
- Rated voltage: 240V – 10A plug
- 2,880rpm
- Wheel size: 150mm(6")
- Vibration absorption pads on base for smoother running and a better finish
- 25mm wide grinding wheels
- 36 and 60 grit wheels standard for fast removal of material
- Wide wheel guards
- Cast iron body and base for hardwearing,
- Capacitor start-stop motor for maximum performance
- Complete with fully adjustable tool rests and eye shields
- 3 year warranty
- Weight: 10.3kg



Item Code	Bishops Code
ATBG280/6	
SPECIAL ORDER: PLEASE QUOTE ITEM CODE UPON ORDERING THIS PRODUCT	

INDUSTRIAL BENCH GRINDER – 200MM



- Powerful Induction motor full 3/4hp PLUS
- Power: 600W
- Rated voltage: 240V – 10A plug
- 2,880rpm
- Wheel size: 200mm(8")
- Vibration absorption pads on base for smoother running and a better finish
- 25mm wide grinding wheels
- 36 and 60 grit wheels standard for fast removal of material
- 50mm wide wheel guards
- Cast iron body and base for hardwearing, long lasting performance
- Capacitor start-stop motor for maximum performance
- Complete with fully adjustable tool rests and eye shields
- 3 year warranty
- Weight: 23kg



Item Code	Bishops Code
ATBG600/8	75010580

BENCH GRINDERS

- For grinding and shaping metal or metallic equipment
- Supplied with coarse and fine grit grinding wheels
- Emergency stop button in the front for those critical moments
- Frequency: 50/60Hz
- No load speed: 2,950rpm



Grinding Wheels	Input Power	Voltage	Motor	Dimensions	Weight	Bishops Code
150(6") x 20 x 12.7mm	250W	240V	0.5hp	350(l) x 185(w) x 235(h)mm	11.5kg	75530100
200(8") x 20 x 32mm	350W	240V	0.5hp	420(l) x 260(w) x 270(h)mm	15kg	75530200
250(10") x 25 x 32mm	750W	415V	1.0hp	485(l) x 350(w) x 360(h)mm	26kg	75530300

INDUSTRIAL BENCH GRINDERS

- Heavy duty industrial design
- Supplied with coarse and fine grit grinding wheels
- Emergency stop button in the front for those critical moments
- 3 phase
- Motor: 1.2hp



Grinding Wheels	Input Power	Voltage	Frequency	Weight	Speed	Bishops Code
200(8") x 32 x 32mm	800W	415V	50Hz	26.5kg	2,850rpm	75530410
250(10") x 32 x 32mm	900W	415V	50Hz	33kg	2,950rpm	75530420
300(12") x 50 x 75mm	2,200W	415V	50/60Hz	84kg	1,450rpm	75530450

BELT & DISC BENCH GRINDER

- Universal applications
- Suitable for deburring and grinding both flat and contoured surfaces
- Powerful 3 phase motor and user friendly safety switch
- Motor power: 1.1kW, 240V
- Frequency: 50Hz
- Grinding disc: 150mm
- Disc speed: 1,410rpm
- Abrasive belt: 75 x 1,180mm
- Belt speed: 11m/s
- Belt size: 75 x 1,180mm
- 665(l) x 460(w) x 370(h)mm
- Weight: 62kg



Item Code	Bishops Code
	75076150

INDUSTRIAL GRINDER & LINISHER



- Allows for fast changes to the working angle without disassembly
- Top platen is suitable for flat surface grinding and can be moved out of the way for convenient free strapping
- Easy belt tracking adjustment knob and lock
- Fast belt changes with self-locking push in push out arm
- Linishing side on right
- Linishing belt: 915 x 50mm, 240 grit
- Linishing belt diameter: 178mm
- Grinding side on left
- Grinding wheel: 25mm(w), 60 grit



Item Code	Grinder Size
AA362W6	150mm (6")
AA362W8	200mm (8")

SPECIAL ORDER: PLEASE QUOTE ITEM CODE UPON ORDERING THIS PRODUCT

LINISHING BELT ATTACHMENT



- Left or right hand side installation on most 150mm and 200mm grinders
- Design allows for fast changes to the working angle without disassembly in 6" increments
- Top platen can be used for flat surface grinding and can be moved out of the way for free strapping
- Easy belt tracking adjustment knob and lock
- Self-locking push in push out arm
- Belt: 915 x 50mm, 240 grit
- Disc: 178mm, 120 grit
- 89mm contact wheel



Item Code	
AA362	
SPECIAL ORDER: PLEASE QUOTE ITEM CODE UPON ORDERING THIS PRODUCT	



ELECTRIC IMPACT & ROTARY DRILLS & HAMMERS

POWER, PNEUMATIC & ENGINE POWERED TOOLS

GSB13RE KLC IMPACT DRILL – 650W



- Robust, twin-sleeve keyless chuck made of metal for fast bit changes
- Speed pre-selection with setting wheel
- Softgrip for a secure hold
- Electronic control for exact pilot drilling
- Forward/reverse rotation
- Continuously variable speed control
- Right-hand/left-hand rotation
- Rated power input: 650W
- No-load speed: 3,150rpm
- Drilling diameter: 13mm (Masonry), 25mm (Wood)
- Torque: 1.8Nm
- Chuck capacity: 1.5–13 mm
- Weight: 1.6kg



Item Code	Bishops Code
0.601.227.142	75006065

GBH 2-26 ROTARY HAMMER – 800W



- Gets the work done quickly due to fast drilling rate and high chiselling performance
- Reliable and robust with long lifetime due to high-quality components
- Wide range of applications with rotation stop for chiselling work
- 800W powerful motor
- 240V
- 2.7J impact energy
- Impact rate at rated speed: 0–4,000bpm
- Rated speed: 0–900rpm
- Tool holder: SDS plus
- Weight: 2.8kg



Item Code	Bishops Code
0.611.2A3.040	75008088

PREMIUM ROTARY HAMMERS



- Optimised hammer mechanism technology and high performance motor
- Good handling for both left and right handed users
- Vibration control
- Tool holder: SDS-Max
- 240V



GBH 12-52 DV

Item Code	Rated Input	Rated Speed	Impact Energy	Impact Rate	Weight	Bishops Code
GBH 5-40 DCE	1,150W	170–340rpm	2–11J	1,500–3,050bpm	6.8kg	75008125
GBH 12-52 DV	1,700W	105–215rpm	19J	1,025–2,100bpm	11.9kg	75008130

GBH 8-45 DV ROTARY HAMMER



- Perfect power-to-weight ratio for performing many SDS max tasks
- Durable due to robust metal components
- Powerful motor enables the delivery of 12.5 J of impact energy for fast drilling and high removal rate
- Impact rate: 1,475–2,700bpm
- Rated speed: 165–300rpm
- Rated input power: 1,500W
- Tool holder: SDS-Max
- Weight: 8.2kg



Item Code	Bishops Code
0.611.265.040	75008128

HAMMER ACTION: IMPACT VS ROTARY

Do you know the drill? Both these drill types pound the cutting surface with force while the end twists to create the hole. However, of the two, the rotary drill reigns supreme in terms of power.

Rotary drills use a piston mechanism instead of a clutch. This causes the drill to deliver a much more powerful hammer blow, making it possible to drill bigger holes much faster.

Our tests show that despite the increased power, rotary drills feel lighter on the hands. Bishops' customers prefer the rotary drill for larger jobs involving harder concrete.

GSH 5 CE DEMOLITION HAMMER SDS-MAX



- 12 chisel position settings for convenience
- Constant electronic capabilities
- Rated Power Input: 1,150W
- Impact Energy: 2–13J
- Impact Rate: 1,300–2,900bpm
- Weight: 6.2kg



Item Code	Bishops Code
0.611.321.040	75008092

GSH 16-30 DEMOLITION HAMMER – 1,750W



- Extremely high material removal rate – up to 13t per day
- Long lifetime due to robust design and high quality material construction
- Vibration control allows longer operating time
- Trolley is supplied as standard for easy and convenient transportation
- Excellent handling thanks to the large handle
- The perfectly positioned on/off switch prevents the tool from being switched off unintentionally
- Rated power input: 1,750W
- Impact energy: 45J
- Impact rate at rated speed: 1,300bpm
- 760(l) x 255(w)mm
- Weight: 16.5kg



Item Code	Bishops Code
0.611.335.140	75008095

MAGNETIC BASE DRILL

- 13,000N or 1,445kg magnetic holding power of base
- Provides stable and accurate drilling
- Suitable for onsite or workshop applications
- Frequency: 50Hz



Output Power	Max. Drilling Capacity	Voltage	Power	Speed	Max. Travel	Bishops Code
1,100W Motor	23mm	220V	1.5hp	330rpm	180mm	75090180
1,600W Motor	32mm	380V	2.14hp	150rpm	220mm	75090185

BENCH DRILL PRESS – 16MM

- ZJ4116 motor
- Emergency stop button in the front for those critical moments
- 0.7hp, 240V, 500W
- Drilling capacity: 16mm
- Spindle travel: 85mm
- Spindle taper: MT2
- 16 speed change
- Speed 50/60Hz: 170–3,080/210–3,700rpm
- Swing: 360mm
- Working table: 290 x 290mm
- Base: 460 x 280mm
- Column diameter: 72mm
- Total height: 1,000mm
- Weight: 38kg



Bishops Code
75520200

MAGNETIC BASE DRILL

- Suitable for engineering, construction, fabrication, infrastructure, mining and marine industries
- Easy operation and high performance
- Heavy duty high power motor
- Durable, high quality construction
- 900ml integrated coolant tank
- Overload protection feature
- Power cut-off safety restart feature
- Sidelock adaptor: 19mm
- 240V, 1,050W
- Hole drilling capacity: 35mm diameter, 50mm deep



Item Code	Bishops Code
SMD35-2	75090197

FLOOR DRILL PRESS – 25MM

- Emergency stop button in the front for those critical moments
- 0.75hp, 240V, 550W
- Drilling capacity: 16mm
- Spindle travel: 85mm
- Chuck: 3–16mm MT2
- 16 speed change
- Speed: 180–2,770rpm
- Swing: 325mm
- Working table: 290 x 290mm
- Base: 460 x 272mm
- Column diameter: 72mm
- Height: 1,580mm
- Weight: 60kg



Bishops Code
75520600

BENCH DRILL PRESS – 13MM

- ZJ4113 motor
- Emergency stop button in the front for those critical moments
- 0.3hp, 250W
- Drilling capacity: 13mm
- Spindle travel: 50mm
- Spindle taper: B16
- 5 speed change
- Speed 50/60Hz: 620–2,620/740–3,140rpm
- Swing: 210mm
- Working table: 160 x 160mm
- Base: 290 x 190mm
- Column diameter: 46mm
- Total height: 590mm
- Weight: 19kg



Bishops Code
75520100

MILLING & DRILLING MACHINES

- Precision machine for drilling, milling and tapping
- No. 4 Morse taper spindle
- 6 step speed



75570200

Cutting Capacity	Table Size	Bishops Code
45mm	800 x 240mm	75570130
40mm	600 x 190mm	75570200



ELECTRIC CIRCULAR SAWS, MITRE & TABLE SAWS

POWER, PNEUMATIC & ENGINE POWERED TOOLS

GKS 190 184MM CIRCULAR SAW – 1,400W

- For rip, cross and mitre cuts in wood and similar materials, mainly in free handling
- Spindle lock for easy changing of saw blades
- Also suitable for left-handers
- Comes with 2 blades
- Blade diameter: 184mm
- No-load speed: 5,500rpm
- Rated power input: 1,400W
- 68mm cut
- 20mm bore
- Weight: 4.1kg



Item Code	Bishops Code
0.601.623.041	75004040

GKS235 235MM CIRCULAR SAW – 2,100W

- Robust stamped steel base plate
- Closed anti-sag aluminium die-cast lower guard without riving knife for longer service life
- Optimised chip ejection system for cleaner material surface
- Ambidextrous lock-off switch on both sides of grip
- Dual guided bevel setting for more stability
- Blade diameter: 235mm
- Blade bore: 25mm
- No-load speed: 5,000rpm
- Rated power input: 2,100W
- Weight: 7.6kg



Item Code	Bishops Code
0.601.5A2.040	75004045

315MM CUT-OFF METAL SAW

- Designed for cutting through hard materials that cannot be cut by a regular grinder
- Ideal for steel fabrication jobs
- Comes on stand
- 3 phase
- Blade speed: 38/19rpm
- 1.1kW input power
- 400V
- Frequency: 50Hz
- Cutting range at 0° round: 70mm
- Cutting range at 0° rectangular: 130 x 70mm
- Cutting range at 0° square: 70 x 70mm
- Cutting range at 45° round: 70mm
- Cutting range at 45° rectangular: 90 x 70mm
- Cutting range at 45° square: 70 x 70mm
- Overall dimensions: 920(l) x 640(w) x 1,510(h)mm
- Weight: 235kg



Item Code	Bishops Code
	75084400

GCO 14-24 J 355MM METAL CUT OFF SAW – 2,400W

- Powerful and robust with high overload capacity even for demanding jobs
- Patented clamping system ensures increased disc utilisation by 20%
- Large base with rubber feet ensures stability on slightly uneven surfaces
- Spindle lock
- Soft start function avoids sudden inrush current during tool start-up
- Cutting disc size: 355mm x 25.4mm (bore)
- No-load speed: 3,800rpm
- Rated power input: 2,400W
- Weight: 18.1kg



Item Code	Bishops Code
0.601.B37.240	75014100

GCM 10 MX 255MM MITRE SAW – 1,800W

- Durable multi-material cutting mitre saw
- Torsion spring carbon brush system with auto-stop function for the longest lifetime
- Solid and compact base with rubber feet
- D-handle with dimples for perfect grip in any condition
- Saw blade diameter: 255mm
- Saw blade bore: 25.4mm
- No-load speed: 4,800rpm
- Rated power input: 1,800W
- Weight: 14.1kg



Item Code	Bishops Code
0.601.B29.040	75004010

GCM 12GDL 305MM COMPACT GLIDE SAW – 1,800W

- Sliding compound mitre saw
- Patented Axial-Glide™ System
- Integrated dual line laser
- Square lock quick release fence
- Up to 110mm height and 341mm cutting width
- Saw blade diameter: 305mm
- Saw blade bore: 30mm
- 2,000W glide saw
- No-load speed: 3,800rpm
- Mitre setting: 52°/60°
- Rated power input: 1,800W
- Weight: 32kg



Item Code	Bishops Code
0.601.B23.640	75004022

GTS 10 XC TABLE SAW & STAND

- Multifunctional table saw
- 2,100W motor with brake, soft start, overload protection and constant speed electronics
- Toolless height adjustable riving knife
- Table size: 584 x 759mm
- No-load speed: 3,200rpm
- Saw blade diameter: 254mm
- Saw blade bore: 25.4mm
- Incline setting: 47°L/1°R
- Weight: 35kg
- Saw stand sold separately



Item Code	Bishops Code
0.601.B30.440	75004025

T1B MITRE SAW STAND

- Lightweight stand for mitre and combo saws
- Universal, compact and easy to transport
- Sturdy design with height adjustment in one leg
- Legs have rubber end caps, and are easily foldable with push button
- Length of work bench: 1,220–2,630mm
- Height: 940mm
- Weight (with accessories) 19kg, (without accessories) 15kg



Item Code	Bishops Code
0.601.B12.310	75004030

GMR 1 PALM ROUTER – 550W

- Suitable for rounding off deck planks and railings, hinge mortising, decorative working on edges, groove cutting, dovetail cutting, window cutouts, decorative inlays, flush trimming and more
- Robust aluminium base is durable, solid and precise
- Depth setting for rough and fine adjustment
- Unique handle recesses for additional stability
- Practical front spindle lock on the motor for easy router bit changes with an open-ended spanner
- Quick-change system for easy locking of the motor
- Angled cable outlet keeps cable out of the way
- Rated power input: 550W
- No-load speed: 33,000rpm
- Weight: 1.5kg



Item Code	Bishops Code
0.601.60A.040	75004035

GTA 6000 SAW STAND

- Stand to suit GTS 10 XC Professional table saw
- Foldable design with lockable folding mechanism
- Easy to store, quick to set up, and simple to transport for convenient work on the go
- 750(l) x 602(h)mm



Item Code	Bishops Code
0.601.B24.100	75004027

GNA 75-16 NIBBLER – 750W

- Strong 750W motor provides optimum power for cutting various materials
- Perfect handling is ensured by the tool's narrow grip circumference
- Nibbler head offers excellent manoeuvrability in curves
- Suitable for steel up to 400N/mm²
- Rated input power: 750W
- Power output: 400W
- No-load stroke rate: 2,600spm
- Weight: 1.8kg



Item Code	Bishops Code
0.601.529.440	75010629

GST 75 BE JIGSAW – 650W

- Bosch SDS for easy, tool-free, two-hand saw blade changes
- Accelerator function switch for smooth pilot sawing
- Sawdust blower enables a clear view, can also be switched off for effective dust extraction
- Exemplary smooth running ensures best results as well as fatigue-free working
- 4-stage pendulum action for tear-free cuts
- Robust steel base plate and aluminium front cap for precise working
- No-load stroke rate: 500–3,100spm
- Rated power input: 650W
- Stroke height: 23mm
- Weight: 2.6kg



Item Code	Bishops Code
0.601.58F.040	75010617

GOP 30-28 OSCILLATING TOOL – 300W

- Best price-to-performance ratio in the Bosch StarlockPlus category
- 300W motor combined with a superior Starlock interface with an optimised 3-dimensional tight-fitting connection between the machine and accessory for the highest possible power transmission
- Small ergonomic handle grip provides comfortable handling and better tool control
- Magnetic mounting enabling easy accessory changes
- Rated input power: 300W
- No-load oscillation: 8,000–20,000opm
- Oscillation angle on left and right: 1.4°
- Weight: 1.5kg



Item Code	Bishops Code
0.601.237.041	75010705

GST 160 CE JIGSAW – 800W

- Compact, lightweight design with narrow grip provides optimal control
- Barrel grip enables ideal cuts from underneath
- Patented double roller saw blade guidance reduces bending for excellent precision
- Reliable 800W motor and constant speed deliver cuts in even the hardest materials
- Rated input power: 800W
- Stroke rate at no load: 800–3,000spm
- Saw stroke length: 26mm
- Weight: 2.2kg



Item Code	Bishops Code
0.601.517.040	75010622

GET MORE AT BISHOPS ▶

WORK BENCHES

Page 158



4 PIECE TILING MULTI-BLADE SET



- Versatile tile set for renovation and reconstruction work
- For use with the Bosch GOP multi-function tools

Includes:

- 1 x Segment saw blade
- 1 x Sanding plate
- 1 x Scraper
- 1 x Metal plunge-cutting saw blade



Item Code
2.608.661.695

Bishops Code
75020129

4 PIECE FLOORING/FITTING SET



- Versatile set for floor/installation work
- For use with the Bosch GOP multi-function tool

Includes:

- 1 x Wood & metal segment saw blade
- 1 x Hard wood plunge-cutting saw blade
- 1 x Wood plunge-cutting saw blade
- 1 x Scraper



Item Code
2608661696

Bishops Code
75020127

23 PIECE ALL-IN-ONE SET



- For use with Bosch GOP 250 CE Professional tool

Includes:

- 1 x Wood & metal segment saw blade
- 1 x Wood & metal plunge-cutting saw blade
- 1 x Scraper
- 10 x Wood-top sanding sheets
- 10 x White paint sanding sheets



Item Code
2608661694

Bishops Code
75020128

GHG 20-63 HEAT GUN – 2,000W



- Two airflow settings and an additional cooling at 50°C, digitally adjustable temperature by steps of 10°C
- High-powered heat gun reaches up to 630°C smoothly thanks to strong 2,000W motor
- Automatic thermal protection switches off the heating unit if motor overheats for increased protection and long lifetime
- Rated power input: 2,000W
- Working temperature: 50°C–630°C
- Airflow: 150–500L/min
- Dimensions: 245(l) x 201(h)mm
- Weight (without cable): 0.65kg



Item Code
0.601.2A6.240

Bishops Code
75010610

DIAMOND ELECTRIC REBAR CUTTER

- Adjusting stopper to suite rebar diameter
- Max. cutting capacity: 20mm (3/4")
- Cutting speed: 4 seconds
- Max. tensile strength: 650N/mm²
- Cutting pressure: 15t
- 230V, 1,050W
- 408 x 109 x 215mm
- Weight: 11.5kg



Item Code
DC20HL

Bishops Code
75040100

DIAMOND REBAR CUTTER

- Can cut up to and including 32mm rebar with 500N/mm² tensile strength
- Cutting speed: 12 seconds
- Cutting pressure: 45t
- 240V
- 591 x 180 x 272mm
- Weight: 35.8kg



Item Code
DC32WH

Bishops Code
75040110

DIAMOND ELECTRIC REBAR BENDER/STRAIGHTENER

- Can bend and straighten up to 32mm rebar with 500N/mm² tensile strength
- Max. diameter capacity: 32mm (1 1/4")
- Bending speed: 12 seconds/90°
- Max. tensile strength: 620N/mm²
- 240V, 2,000W
- 686 x 284 x 217mm
- Weight: 28kg



Item Code
DBR-32HD

Bishops Code
75040120

GHO 26-82 D PLANER – 710W



- Strong 710W motor delivers fast and accurate results
- Adjustable dual chip extraction system for comfortable dust removal and clean work surface
- Compact shape provides convenient handling and performs well in hard-to-reach spaces
- Rated power input: 710W
- Planing depth: 2.6mm
- Planing width: 82mm
- Adjustable rebating depth: 0–9mm
- No-load speed: 18,000rpm
- Weight: 2.8kg
- Replacement blades sold separately



Item Code
0.601.5A4.340

Bishops Code
75012100

GEX 125-1 AE RANDOM ORBITAL SANDER – 400W



- Low vibration for reduced fatigue
- Fully decoupled housing for the best removal rate and highest surface quality of its class
- High mobile dust collection rate with Bosch Micro filter dust box – environmentally friendly
- Comes with interchangeable 125mm and 150mm Velcro pads
- Greaseless friction brake for quick stops
- Direct access to vacuum cleaner hose without an adaptor
- No-load speed: 5,500–12,000rpm
- Sanding plate diameter: 125mm
- Oscillating circuit diameter: 4mm
- Rated power input: 400W
- Weight: 2.4kg



Item Code	Bishops Code
0.601.387.540	75004065

GEX 40-150 6" RANDOM ORBITAL SANDER



- The high-performance 150mm random orbit sander for professional finishes
- Housing with a decoupled sanding unit for consistent contact pressure, enabling high-quality surface results
- Unique vibration damping produces very low vibrations for continuous work
- Multi-hole sanding pad for sanding sheets with different hole pattern and for significantly increased dust extraction
- Velcro disc
- Disc size: 150mm
- Rated input power: 400W
- 230V
- No-load speed: 5,500–12,000rpm
- Orbital stroke rate: 11,000–24,000opm
- Eccentricity: 2mm
- Weight: 2.4kg



Item Code	Bishops Code
0.601.37B.240	75004070

ORBITAL SANDERS



- Automatic paper tensioning
- Low vibration for fatigue-free working
- Long lifetime due to sealed ball bearing and the high quality white sanding plate
- Accepts 93 x 230mm clamp-type sanding sheets and 93 x 185mm Velcro-type sanding sheets



GSS 23 AE

Item Code	Rated Power Input	No-Load Speed	Oscillating Circuit Dia.	Weight	Bishops Code
GSS 23 AE	190W	7,000–12,000rpm	2.0mm	1.7kg	75004078
GSS 280 AVE	350W	8,000–11,000rpm	2.4mm	2.7kg	75004079

GPO 12 CE SANDER POLISHER – 1,250W



- Optional side handle and D-handle
- Variable speed control for adapting to a wide range of applications
- Ergonomic handle design with softgrip for comfortable handling
- Integrated lock-on function for easy control
- Spindle lock for convenient accessory change
- Comes with lambswool bonnet for polishing plate
- Rated power input: 1,250W
- No load speed: 750–3,000rpm
- Sanding plate: 180mm
- Grinding spindle thread: M14



Item Code	Bishops Code
0.601.389.040	75004062

SET UP YOUR PNEUMATIC WORKSHOP

No matter what parts and accessories you need for your pneumatic workshop, you can find them at Bishops.

Air Compressors

We've got a great range of machines to choose from. If you want an electric model, choose between single or 3 phase power input. If you're looking at engine powered, choose between petrol or diesel models. Whether you want to pick up a smaller, mobile option or a heavier stationary model, Bishops is your one stop pneumatic shop. Check 'em out in the Workshop section starting page 327.



Air Hose & Fittings

Bishops has all the air hose and fittings you could ever need. Pick up an air hose assembly with hose and fittings included, or purchase hose cut to length and fittings separately. Air hose starts from page 476 and fittings are just after on page 488.



Filters, Regulators & Lubricators

Without these little things in place, you run the risk of contaminants in your air supply affecting your tools and workpiece, leading to delays, potential danger and damage in your workshop. Make sure you're covered – see our full range starting on page 503.



We've got all the little things you need to power and maintain your pneumatic powered workshop. Find them at Bishops!



PNEUMATIC ANGLE & DIE GRINDERS

POWER, PNEUMATIC & ENGINE POWERED TOOLS

PNEUMATIC ANGLE GRINDERS

- Front exhaust
- Powerful 0.78hp motor provides sufficient power for most grinding applications
- Strengthened alloy steel bevel gears dramatically improve performance and durability
- Equipped with safety throttle lever
- Spindle: 3/8"-24
- Free speed: 11,000rpm
- Avg. air consumption: 6.0cfm (170L/min)
- Air pressure: 90psi (6.3bar)
- Air hose: 3/8"
- Sound pressure: 87.8dBA
- Overall length: 230mm
- Weight: 3.24kg



Item Code	Disc Diameter	Bishops Code
QB114	100mm	73625025
QB115	125mm	73625035

180MM PNEUMATIC ANGLE GRINDER

- Front exhaust
- Powerful 1.0hp motor provides plenty of power for rust and material removal
- Unique motor controller (Governor) virtually eliminates over speed
- Disc diameter: 7"
- Free speed: 7,000rpm
- Avg. air consumption: 9.0cfm (255L/min)
- Air pressure: 90psi (6.3bar)
- Air hose: 1/2"
- Sound pressure: 89.7dBA
- Overall length: 343mm
- Weight: 3.24kg



Item Code	Bishops Code
QB-117	73625065

1/4" MICRO PNEUMATIC DIE GRINDER

- Cushioned handle grip provides non-slip surface
- Stainless steel front housing eliminates rust
- Ideal for machining dies, moulds or other tiny grinding applications
- Collet size: 1/8"
- Free speed: 60,000rpm
- Avg. air consumption: 2.7cfm (76L/min)
- Air pressure: 90psi (6.3bar)
- Hose length: 1.5m
- Air hose: 3/8"
- Sound pressure: 70dBA
- Overall length: 152mm
- Weight: 0.22kg



Item Code	Bishops Code
QA-421	73625905

1/4" PNEUMATIC DIE GRINDER

- Handy and ergonomic design provides excellent manoeuvrability
- Speed regulator allows precise speed control
- 1/8" and 1/4" collets are included
- Equipped with 5" extended working shaft
- Free speed: 25,000rpm
- Avg. air consumption: 10cfm (283L/min)
- Air pressure: 90psi (6.3bar)
- Motor: 0.3hp
- Air hose: 3/8"
- Sound pressure: 81.5dBA
- Overall length: 280mm
- Weight: 0.63kg



Item Code	Bishops Code
QA-315B	73625140

1/4" HEAVY DUTY PNEUMATIC DIE GRINDER

- 0.9hp high power motor efficiently handles the toughest jobs
- 1/8" and 1/4" collets included
- Free speed: 20,000rpm
- Avg. air consumption: 10cfm (283L/min)
- Air pressure: 90psi (6.3bar)
- Air hose: 3/8"
- Sound pressure: 75.7dBA
- Overall length: 190mm
- Weight: 0.65kg



Item Code	Bishops Code
QA-211B	73625130

15 PIECE PNEUMATIC DIE GRINDER SET

- Free speed: 25,000rpm
 - Avg. air consumption: 10cfm (283L/min)
 - Air pressure: 90psi (6.3bar)
 - Motor: 0.3hp
 - Air hose: 3/8"
 - Sound pressure: 81.5dBA
 - Overall length: 155mm
 - Weight: 0.38kg
- Includes:**
- 1 x 1/4" Air die grinder
 - 1 x 1/8" Collet
 - 2 x Spanner wrenches
 - 5 x 1/8" Grinder stones
 - 5 x 1/4" Shank stones
 - 1 x Plug



Item Code	Bishops Code
QA-0115B	73625180

15 PIECE HEAVY DUTY PNEUMATIC DIE GRINDER SET

- Free speed: 20,000rpm
 - Avg. air consumption: 10cfm (283L/min)
 - Air pressure: 90psi (6.3bar)
 - Motor: 0.9hp
 - Air hose: 3/8"
 - Sound pressure: 75.7dBA
 - Overall length: 190mm
 - Weight: 0.65kg
- Includes:**
- 1 x 1/4" Air die grinder
 - 1 x 1/8" Collet
 - 2 x Spanner wrenches
 - 5 x 1/8" Grinder stones
 - 5 x 1/4" Shank stones
 - 1 x Plug



Item Code	Bishops Code
QA-0215B	73625170

GET MORE AT BISHOPS



MOUNTED POINTS

Page 123

3/8" PNEUMATIC REVERSIBLE DRILL

- Capable of retracting drill bit reversely after drilling
- Convenient forward/reverse switch allows fast direction change
- Handle exhaust efficiently reduces noise and directs air away from working area
- Keyed chuck
- Chuck size: 10mm
- Free speed: 1,800rpm
- Avg. air consumption: 6.5cfm (184L/min)
- Air pressure: 90psi (6.3bar)
- Air hose: 3/8"
- Sound pressure: 92dBA
- Overall length: 203mm
- Weight: 1.1kg



Item Code	Bishops Code
QE-333	73615020

1/2" PNEUMATIC REVERSIBLE DRILL

- Capable of retracting drill bit reversely after drilling
- Convenient forward/reverse switch allows fast direction change
- Handle exhaust efficiently reduces noise and directs air away from working area
- Side handle bar included, improving stability
- Keyed chuck
- Chuck size: 13mm
- Free speed: 800rpm
- Avg. air consumption: 6.5cfm (184L/min)
- Air pressure: 90psi (6.3bar)
- Air hose: 3/8"
- Sound pressure: 97.5dBA
- Overall length: 230mm
- Weight: 1.8kg



Item Code	Bishops Code
QF-343	73615040

1/2" PNEUMATIC IMPACT WRENCH

- Equipped with twin hammer impact mechanism
- Compact volume, ideal for confined working environment
- Low noise, lightweight, yet strong and powerful
- Torque range: 150–350ft-lb (203–475Nm)
- Max. torque: 400ft-lb (542Nm)
- Free speed: 10,000rpm
- Avg. air consumption: 4.2cfm (119L/min)
- Air pressure: 90psi (6.3bar)
- Air hose: 3/8"
- Sound pressure: 90.6dBA
- Weight: 4.6kg



Item Code	Bishops Code
NC-4210	73630040

1/2" PNEUMATIC IMPACT WRENCH

- Equipped with twin hammer impact mechanism
- Efficient and reliable torque output during operation
- Handle exhaust efficiently reduces the noise and directs air away from the working spot
- Torque range: 180–500ft-lb (244–678Nm)
- Max. torque: 700ft-lb (949Nm)
- Free speed: 7,500rpm
- Avg. air consumption: 4.5cfm (127L/min)
- Air pressure: 90psi (6.3bar)
- Air hose: 3/8"
- Sound pressure: 87dBA
- Weight: 4.5kg



Item Code	Bishops Code
NC-4230	73630060

PICKING A PNEUMATIC IMPACT WRENCH

If you've ever tried to loosen a large, fretted or corroded fastener then you must have wished you had a Pneumatic Impact Wrench. Many professions and industries use impact wrenches, including automotive repair, product assembly, machinery maintenance and building construction.

Torque

Match the torque of your tool to the requirements of your job. Having enough torque to remove a fastener is the most important factor. Higher torque makes for a more capable impact wrench. We recommend going for high torque first, then as high as you can with the impact rate.

The maximum torque an impact drill can achieve goes hand-in-hand with the drive inch size of the drill – the larger the drive inch, the greater the possible maximum torque – for example 1/2" can handle less torque than 3/4". The most important thing is to make sure your impact wrench has the right torque needed to finish the job as each application has different requirements.

Drive Size

Impact wrenches are available in every standard socket wrench drive size, from small 1/4" drive tools for small assembly and disassembly, up to 3 1/2" and larger square drives for major construction. The most common sizes are 1/2" and 3/4", with the latter being our most popular due to its higher maximum torque.

Impact Rate

BPM (Beats Per Minute) should be suitably high enough because this power tool requires a lot of contact to push down a screw or bolt to tighten or loosen it.

Weight

Impact wrenches should be light enough for extended use and ease in carrying. Lighter is always better if you are using the tool to screw in nuts and bolts with force.

How Much Torque Do I Need?

Bolt Size	Max. Torque Needed	RECOMMENDED CHOICE						
		1/4"	3/8"	1/2"	3/4"	1"	1 1/2"	
M8	45Nm	Green	Green	Green	Green	Green	Green	
M10	90Nm	Green	Green	Green	Green	Green	Green	
M14	260Nm	Green	Green	Green	Green	Green	Green	
M16	400Nm	Green	Green	Green	Green	Green	Green	
M18	550Nm	Green	Green	Green	Green	Green	Green	
M20	800Nm	Green	Green	Green	Green	Green	Green	
M24	1,300Nm	Green	Green	Green	Green	Green	Green	
M27	2,000Nm	Green	Green	Green	Green	Green	Green	
M30	2,700Nm	Green	Green	Green	Green	Green	Green	
M30 <	2,700Nm <	Green	Green	Green	Green	Green	Green	

Green: Suited for the job
 Yellow: Infrequent use only, consider upgrading/downgrading

1/2" PNEUMATIC IMPACT WRENCH



- Designed for heavy duty and industrial work
- Aluminium alloy housing
- Powerful twin hammer
- Durable CR-MO anvil square driver
- Variable speed trigger
- Muffled handle exhaust
- Standard anvil
- Length: 194mm
- Weight: 2.8kg
- Avg. air consumption: 125L/min
- Air inlet: 1/4" BSPT
- Max. torque: 880Nm
- No load speed: 8,000rpm



Item Code	Bishops Code
33411-050	73630520



PNEUMATIC IMPACT & RATCHET WRENCHES

POWER, PNEUMATIC & ENGINE POWERED TOOLS

3/4" PNEUMATIC IMPACT WRENCH



- Designed for heavy duty and industrial work
- Aluminium alloy housing
- Powerful twin hammer
- Durable CR-MO anvil square driver
- Variable speed trigger
- Muffled handle exhaust
- Standard anvil
- Length: 228mm
- Weight: 4.5kg
- Avg. air consumption: 198L/min
- Air inlet: 1/4" BSPT
- Max. torque: 1,085Nm
- No load speed: 6,500rpm



Item Code	Bishops Code
33621-075	73630550

3/4" PNEUMATIC IMPACT WRENCH



- Lightweight
- One-handed F/R control, easy forward/reverse switch
- 4-speed power setting, full speed in reverse
- TPR Handle that can help to reduce the effect of vibration on the operator
- Max. torque: 1,100ft-lb (1,491Nm)
- Free speed: 8,000rpm
- Avg. air consumption: 6.7cfm (190L/min)
- Air inlet: 1/4" BSPT
- Sound pressure: 96dBA
- Weight: 2.35kg



Item Code	Bishops Code
33681-100	73630120

3/4" PNEUMATIC IMPACT WRENCH



- Aluminium alloy housing
- Powerful new twin hammer
- Durable CR-MO anvil square driver
- Variable speed trigger
- Designed for heavy duty and industrial work
- Long anvil
- Avg. air consumption: 198L/min
- Air inlet: 1/4" BSPT
- Max. torque: 1,085Nm
- No load speed: 6,500rpm
- Length: 330mm
- Weight: 5kg



Item Code	Bishops Code
33622-075	73630560

1" PNEUMATIC IMPACT WRENCH

- Twin hammer type
- 6" extended anvil
- Max. torque: 1,800ft/lb
- No load speed: 6,000rpm
- Avg. air consumption: 9.0cfm (254L/min)
- Air pressure: 90psi
- Air hose: 1/2"
- Sound pressure: 102dBA
- Length: 487mm
- Weight: 8.4kg



Item Code	Bishops Code
NC-8226	73630564

1" PNEUMATIC IMPACT WRENCH



- Aluminium alloy housing
- Powerful new twin hammer
- Durable CR-MO anvil square driver
- Variable speed trigger
- Designed for heavy duty and industrial work
- Standard anvil
- Avg. air consumption: 255L/min
- Air inlet: 1/2" BSPT/NPT
- Max. torque: 2,440Nm
- No load speed: 4,000rpm
- Length: 371mm
- Weight: 11.5kg



Item Code	Bishops Code
33831-180	73630570

1" PNEUMATIC IMPACT WRENCH



- Aluminium alloy housing
- Powerful new twin hammer
- Durable CR-MO anvil square driver
- Variable speed trigger
- Designed for heavy duty and industrial work
- Long anvil
- Avg. air consumption: 255L/min
- Air inlet: 1/2" BSPT/NPT
- Max. torque: 2,440Nm
- No load speed: 4,000rpm
- Length: 523mm
- Weight: 12.5kg



Item Code	Bishops Code
33832-180	73630580

1 1/2" PNEUMATIC IMPACT WRENCH



- Chrome vanadium alloy steel
- Phosphate sunk finish
- Aluminium alloy housing
- Nickel chrome molybdenum square drive
- Variable speed trigger
- Muffled on handle exhaust
- Air inlet: 1/2" BSPT
- Avg. air consumption 453L/min
- Max. torque 4,065Nm
- No load speed: 3,000 RPM



Item Code	Bishops Code
33921-300	73630590

QUICK RELEASE PNEUMATIC RATCHET WRENCHES



- Quick release button enables fast and efficient socket change
- High speed of revolution (rpm) allows fast positioning
- Hardened gears, needle and ball bearings provide longer lifetime
- Ultimate torque: 45ft-lb
- Torque range: 10-45ft-lb (13.5-61Nm)
- Max. torque: 60ft-lb (81Nm)
- Free speed: 160rpm
- Avg. air consumption: 4.0cfm (113.28L/min)
- Air pressure: 90psi (6.3bar)
- Air hose: 3/8"
- Overall length: 265mm
- Weight: 1.22kg



Item Code	Square Drive	Sound Pressure	Bishops Code
NE-322	3/8"	90.5dBA	73640145
NE-434	1/2"	89.8dBA	73640150

PNEUMATIC SHEARS

- Heat treated shear blades for long lasting cutting performance
- Cutting capacity: up to 1.5mm (aluminium), 1.2mm (steel) and 1.0mm (stainless steel)
- Stroke: 2,600spm
- Air consumption: 6.5cfm (184L/min)
- Air pressure: 90psi (6.3bar)
- Air hose: 3/8"
- Sound pressure: 89.1dBA
- Vibration level: 2.9m/s²
- Overall length: 210mm
- Weight: 1.1kg



Item Code	Bishops Code
QG-202	73635110

PNEUMATIC NEEDLE SCALER

- Wide and complete air tool range
- Adding extra chisels allows for a wider working range
- Scaling rods made from special spring steel, improving the life span of the product
- Stroke length: 28mm
- Blows per minute: 4,600bpm
- Avg. air consumption: 15cfm (424L/min)
- Air pressure: 90psi (6.3bar)
- Air hose: 3/8"
- Sound pressure: 91dBA
- Overall length: 460mm
- Weight: 2.8kg

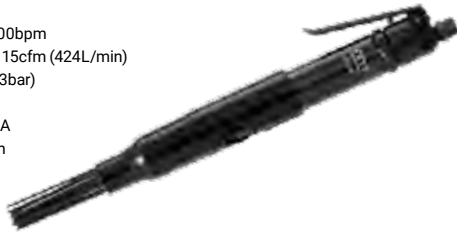

Item Code	Bishops Code
SN-1268	73610106

STRAIGHT PNEUMATIC NEEDLE GUN

- Straight style
- Includes 12 needles
- Needle size: 3 x 125mm
- Stroke length: 32mm
- Blows per minute: 5,500bpm
- Air consumption: 3cfm (90psi)
- Inlet: 1/4"
- Length: 290mm



Item Code	Bishops Code
SN-1288A	73610108

JET CHISEL PNEUMATIC NEEDLE GUN

- Straight type
- Medium duty jet chisel
- Removes weld slag, rust, paint and scale from most surfaces
- Ideal for bridgework, bricks, stone, and many other materials used in industrial and maritime applications
- Air pressure: 85psi
- Air consumption: 201L/min (7.1cfm)
- Strokes/min: 4,000
- 12 needles, 3 x 180mm (2mm needles optional)
- Hose: 3/8" ID
- Weight: 2.4kg



Item Code	Bishops Code
JT-20	73610100

JET CHISEL PNEUMATIC NEEDLE GUN

- Straight type
- Low vibration outer sleeve construction
- Adjusts automatically to any surface contour
- Maximum performance
- Includes 3mm needles (2mm needles optional)
- Strokes/min: 4,000
- Air consumption: 200L/min (7.1cfm)
- Hose: 3/8" ID
- Weight: 2.4kg



Item Code	Bishops Code
JEX-20	73610105

PISTOL GRIP PNEUMATIC NEEDLE GUN

- Pistol style grip
- Includes 19 needles
- Needles size: 180 x 3.0mm
- Stroke length: 33mm
- Blows per minute: 3,700bpm
- Air consumption: 15cfm (90psi)
- Inlet: 1/4"
- Length: 330mm



Item Code	Bishops Code
SN-2110	73610109

JET CHISEL PNEUMATIC NEEDLE GUN

- Universal type
- Pistol grip
- Square needle guide provides intense descaling
- Delivers years of trouble-free, efficient operation
- Includes 3mm needles (2mm needles optional)
- Strokes/min: 4,000
- Air consumption: 220L/min (9.5cfm)
- Hose: 3/8" ID
- Weight: 2.7kg



Item Code	Bishops Code
JEX-24	73610107

JET CHISEL PNEUMATIC NEEDLE GUN

- Pistol grip
- Ideal for heavy duty applications
- Cleans and descales all jobs fast
- Includes 3 and 4mm needles (2mm needles optional)
- Powered by a piston which produces no irregular power
- Heavy duty
- Air consumption: 250L/min (12.4cfm)
- Strokes/min: 4,500
- Hose: 3/8" ID
- Weight: 3.5kg



Item Code	Bishops Code
JEX-28	73610110



PNEUMATIC CHISEL HAMMERS, SANDERS, RIVETERS & BLOWGUNS

POWER, PNEUMATIC & ENGINE POWERED TOOLS

7 PIECE PNEUMATIC CHISEL HAMMER SET



- Includes:**
- Air hammer
 - 5 x Hex shank chisel kit
 - Spring retainer
 - Blow moulded case



Item Code	Bishops Code
5H210BP	73610040

7 PIECE PNEUMATIC CHISEL HAMMER SET



- Alloyed steel cylinder and piston improves the lifetime of the product
 - Round shank
 - Shank opening: 10.2mm
 - Blows per minute: 3,200bpm
 - Avg. air consumption: 4.0cfm (113L/min)
 - Air pressure: 90psi (6.3bar)
 - Air hose: 3/8"
 - Sound pressure: 98dBA
 - Overall length: 175mm
 - Weight: 1.7kg
- Includes:**
- 1 x Air hammer
 - 5 Piece chisel kit
 - 1 x Spring retainer



Item Code	Bishops Code
	73610030

6" PNEUMATIC RANDOM ORBITAL SANDER – NON-VACUUM



- Rubber palm grip allows one hand operation
- Lightweight cast aluminium housing improves durability and lifetime
- Excellent for refinishing or smoothing the surface of metal, wood and leather
- 5mm orbit for fine finishes
- USA. made, 6 hole, hook and loop type urethane pad
- Free speed: 10,000rpm
- Avg. air consumption: 3.85cfm (109L/min)
- Air pressure: 90psi (6.3bar)
- Motor: 0.24hp
- Air hose: 3/8"
- Sound pressure: 74.4dBA
- Overall length: 166mm
- Weight: 0.85kg



Item Code	Bishops Code
QB-42602	73650110

6" PNEUMATIC RANDOM ORBITAL SANDER – SELF-GENERATED VACUUM



- Rubber palm grip allows one hand operation
- Special rubber shroud provides maximum vacuum and no air leakage
- Air hose and vacuum hose are both included
- 5mm orbit for fine finishes
- USA. made, 6 hole, hook and loop type urethane pad
- Excellent for refinishing or smoothing the surface of metal, wood and leather
- Free speed: 10,000rpm
- Avg. air consumption: 3.85cfm (109L/min)
- Air pressure: 90psi (6.3bar)
- Motor: 0.24hp
- Air hose: 3/8"
- Sound pressure: 83dBA
- Overall length: 221mm
- Weight: 1.54kg



Item Code	Bishops Code
QB-43902	73650120

1/4" HEAVY DUTY PNEUMATIC HYDRAULIC RIVETER



- Aluminium alloy forged plunger housing provides greater strength and durability
- Adjustable rivet clamping is designed for obtaining the most effective stroke and riveting speed
- Durable alloy steel chuck jaws equipped to improve performance and lifetime of the product
- Universal air inlet efficiently prevents air hose winding around
- Refer to the specification table of riveters prior to purchase
- Comes with 2.4, 3.2, 4.0 and 4.8mm nosepieces
- Traction power: 900ft·kg (1,983ft·lb)
- Stroke length: 18mm
- Capacity: 2.4–4.8mm
- Air pressure: 90psi (6.3bar)
- Avg. air consumption: 1.8cfm (50L/min)
- Air hose: 3/8"
- Sound pressure: 75.3dBA
- Weight: 1.74kg



Item Code	Bishops Code
PA-312	73635210

PNEUMATIC ENGRAVING PEN



- Comfortable handle allows smooth operation
- Long lifetime and low vibration
- Stainless steel front housing eliminates rust
- 13,000rpm
- Average air consumption: 1.0cfm (29L/min)
- Air pressure: 90psi (6.3bar)
- Motor: 1,420hp
- Air hose: 3/8"
- Sound pressure: 78dBA
- Overall length: 140mm
- Weight: 230g



Item Code	Description	Bishops Code
QA-511	Engraving Pen	73625910
QA-511P12	Thick Plate Needle to Suit	73695580

PNEUMATIC ENGINE CLEANING GUN

- Most suitable for cleaning vehicle engines and body work
- Nitto style fittings
- Aluminium pot
- Cup capacity: 600cc
- Operating pressure: 90psi
- Air inlet: 1/4"



Item Code	Bishops Code
	73620020

BLOW GUNS



- Ideal for cleaning
- Steel nozzle and nylon fiber handle
- BSPT air inlet
- Air consumption:
 - 1/4" hose: 13cfm (350L/min)
 - 3/8" hose: 15cfm (430L/min)
- Sound pressure: 85–90dB
- Working pressure: 75–120psi (5–8kg)
- Recommended air pressure: 90psi
- Max pressure: 220psi (15kg)



Item Code	Overall Length	Nozzle Length	Weight	Bishops Code
79900-04	242mm	100mm	200g	73605070
79900-10	402mm	250mm	240g	73605074
79900-20	652mm	500mm	300g	73605076



BISHOPS

STIHL



Bishops have fully equipped Stihl workshops in all branches and carry over 1,000 different spare parts in PNG.

Find your nearest Stihl workshop at any of these locations

Port Moresby

Wards Road
Ph: (675) 325 1088
Fax: (675) 325 0083

Kimbe

San Remo Drive
Ph: (675) 983 5500
Fax: (675) 983 5308

Madang

Kaislan Avenue
Ph: (675) 422 1344
Fax: (675) 422 1594

Lae

Cnr Malaita & Malekula St
Ph: (675) 472 3799
Fax: (675) 472 6327

Kokopo

Kamuk Street
Ph: (675) 982 9911
Fax: (675) 982 9912

Mt Hagen

Okuk Highway
Ph: (675) 545 1990
Fax: (675) 545 1019



EARTH AUGER DRILL, CUT-OFF SAWS & CHAINSAWS

POWER, PNEUMATIC & ENGINE POWERED TOOLS

BT 45 2 STROKE EARTH AUGER

STIHL

- Hand-held petrol drill that can be used for many different farming and commercial applications
- Displacement: 27.2cm³
- Power output: 0.8 kw (1.1bhp)
- Tank volume: 240.00
- Weight: 4.8kg



Item Code	Bishops Code
4314200 0025	75092065

TS 420 350MM CUTQUIK® CUT-OFF SAW

STIHL

- Compact and robust 3.2kW cut-off saw with a 350mm cutting wheel for use on all types of jobs
- The innovative long-life air filter system with cyclone air routing ensures an extremely long filter service life and increases service intervals
- Can be operated by hand or together with an FW 20 cart
- STIHL 2-MIX engine features an advanced stratified charge system that boosts power
- Long-life air filter system with cyclone air routing
- Compensator – controller in the carburettor prevents the fuel-air mixture getting richer as the air filter becomes clogged
- Anti-vibration system
- Manual fuel pump
- Decompression valve
- Ergonomic grip position
- Cut-off wheel: 350mm
- Displacement: 66.7cc
- Power output: 3.2kW(4.4bhp)
- Weight (without fuel & blade): 9.6kg



Item Code	Description	Bishops Code
4238 011 2808	TS 420 Cut-Off Saw	76570208
0835 090 7044	D-B20 Diamond Cutting Wheel to Suit – 350 x 3mm	75843780

TS 800 400MM CUTQUIK® CUT-OFF SAW

STIHL

- Powerful 5.0kW cut-off saw for 400 or 416mm cutting wheels
- Suitable for cutting metal, concrete and asphalt in commercial applications
- Extremely long filter service life and increased service intervals thanks to innovative long-life air filter system with cyclone air routing
- Can be operated by hand or together with an FW 20 cart
- STIHL 2-MIX engine features an advanced stratified charge system that boosts power
- ElastoStart reduces the shock caused by the compression of the engine during starting
- Compensator – controller in the carburettor prevents the fuel-air mixture getting richer as the air filter becomes clogged
- Long-life air filter system with cyclone air routing
- Anti-vibration system
- Decompression valve
- Ergonomic grip position
- Manual fuel pump
- Cut-off wheel: 400mm
- Displacement: 98.5cc
- Power output: 5kW(6.7bhp)
- Weight: 13kg



Item Code	Description	Bishops Code
4224 011 2808	TS 800 Cut-Off Saw	76570210
0835 090 7044	D-B20 Diamond Cutting Wheel to Suit – 400 x 3mm	75843785

MS 250 CHAINSAW

STIHL

- The MS 250 is light enough to move through smaller tasks like clearing or cleanup but packs a powerful enough punch to cut through small limbs and trees
- A combination of features and a high power-to-weight ratio makes this one of the best homeowner chainsaws on the market
- Power-to-weight ratio: 2 kg/kW
- Sound pressure level: 99dB(A)
- Sound power level: 111dB(A)
- Vibration level: 5.7m/s² (left), 6.8m/s² (right)
- Saw chain pitch: 3/8" P
- STIHL Oilomatic saw chain type: Picco Micro 3 (PM3)
- 50cm/20" bar
- Displacement: 45.4 cm³
- Power output: 2.3 kW/3.1bhp
- Weight: 4.6 kg



Item Code
MS 250

SPECIAL ORDER: PLEASE QUOTE ITEM CODE UPON ORDERING THIS PRODUCT

MS 382 CHAINSAW

STIHL

- This commercial chainsaw provides power and performance for heavy-duty farming and commercial applications. Ideal for logging and cutting firewood
- This saw has a decompression valve and ElastoStart for easier starting
- Anti-vibration system
- Compensator – controller in the carburettor prevents the fuel-air mixture getting richer as the air filter becomes clogged
- STIHL Oilomatic saw chain pitch: 3/8"
- 50cm (20") bar
- Displacement: 72.2cc
- Power output: 3.9kW (5.3hp)
- Power-to-weight ratio: 1.7kg/kW
- Weight: 6.6kg



Item Code	Bishops Code
1119 200 0352	75092014

MS 661 NON M-TRONIC CHAINSAW

STIHL

- Displacement: 91.1 cm³
- Power output: 5.4kW (7.3bhp)
- Weight: 7.4 kg
- Power-to-weight ratio: 1.4kg/kW
- Sound pressure level: 105dB(A)
- Sound power level: 118dB(A)
- Vibration level left-right: 6.9-5.6m/s²
- Saw chain pitch: 3/8"
- STIHL Oilomatic saw chain type: Rapid Super



Item Code	Bishops Code
1144 200 0505	75092020

MS 720 FORESTRY CHAINSAW

STIHL

- Anti-vibration system
- Decompression valve
- Compensator – controller in the carburettor prevents the fuel-air mixture getting richer as the air filter becomes clogged
- Ematic-System ensures pinpoint lubrication of the saw chain links and guide bar rails
- Single-lever master control
- Displacement: 105.7cc
- Power output: 4.8kW (6.5bhp)
- Weight: 10.8kg



Item Code	Bishops Code
1106 200 0021	75092024

HS 45 HEDGE TRIMMER

STIHL

- Compact and lightweight
- Suitable for trimming and shaping hedges in domestic and light commercial applications
- Anti-vibration system
- Double-sided blade
- ElastoStart reduces the shock caused by the compression of the engine during starting
- Electronic ignition module ensures reliable starting and trouble-free running
- Manual fuel pump
- Cutter blade: 450mm
- Displacement: 27.2cc
- Power output: 0.75kW (1.0bhp)
- Weight: 5kg



Item Code	Bishops Code
4228 011 2935	75092062

ENGINE POWERED SAWMILLS

- Electric start
- Honda engine
- Double cut capable
- 1.0 and 1.3m diameter log options – although any diameter may be sawn

75857005 & 75857010:

- Manual blade swing
- Single end horizontal sizing
- Double end vertical sizing
- Log setup taper alignment included

75857015 & 75857025:

- Automatic blade swing
- Operable in both auto and manual modes
- Single end horizontal and vertical sizing



Item Code	Power	Log Dia.	Log Cut Length	Milling Capacity	Bishops Code
M6-13M	13hp	1.0m	4.2m	<4m ³ /day	75857005
M8-13M	13hp	1.3m	6.0m	<4m ³ /day	75857010
M8	22hp	1.3m	6.0m	<6m ³ /day	75857015
M10-28A	22hp	1.3m	6.0m	<6m ³ /day	75857025

HT 105 PETROL POLE PRUNER

STIHL

- Powerful 1.05kW pole pruner for professional users working in tree maintenance, orchards and municipal maintenance
- For pruning trees, removing dead wood and breakage from storms, and for cutting fruit trees
- 1/2" PM3 saw chain, lightweight magnesium transmission with cast-on, robust branch hook for easy removal of loose cuttings from the tree
- Particularly rigid and guidable professional telescopic shaft with rapid adjustment for precise biting characteristics and a precise cut
- Captive nut and integrated direction guide on the sprocket cover
- 4-MIX® engine with simplified start system
- Lateral chip ejection to reduce clogging
- Total length: 270–390cm
- Displacement: 31.4cm³
- Tank volume : 530L
- Saw chain pitch: 1/4"P
- Total length (max): 3.9cm²
- Bar length: 30cm
- Weight: 7.9kg



Item Code	Bishops Code
4182 200 0205	75092064

PORTABLE ALASKAN SAWMILL



- The Edging Mill converts logs into timber or smooth lumber
- Comes complete with 12' of aluminium guide rail in 2' lengths, with screws
- The Alaskan Mill is the advanced design lumber mill for versatile, heavy duty use
- Allows timber to be milled on-site from fallen trees or logs
- Converts rough logs into perfectly-dimensioned timber with a beautiful even re-sawn finish

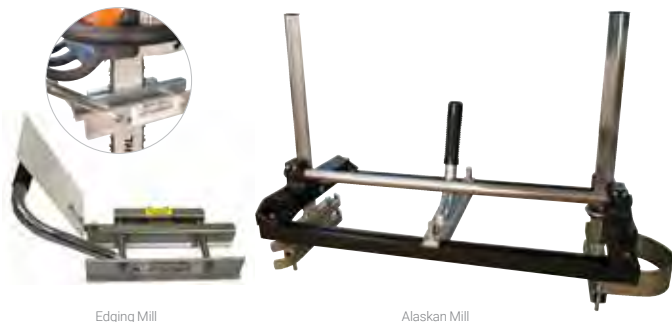

Edging Mill

Alaskan Mill

Item Code	Description	Bishops Code
G555-B	Edging Mill	75092096
G776-36	Alaskan Mill – 36"	75092098

GET MORE AT BISHOPS



CHAINSAW CHAPS

Page 80



FS 55 CE BRUSHCUTTER

- Compact and lightweight grass trimmer for domestic and light-commercial mowing and clearing applications
- Includes Easy2Start for effortless starting
- Bullbar handle



STIHL

Item Code	Bishops Code
4140 200 0567	75092039

FS 55 R CE BRUSHCUTTER

- Displacement: 27.2 cm³
- Power output: 0.75/1kW/bhp
- Sound pressure level with plastic tool: 95 dB(A)
- Sound power level: 108 dB(A)
- Cutting tool: AutoCut 25-2
- Vibration level, left/right with plastic tool: 8.5/8.5 m/s²
- Total length: 170cm
- Weight: 4.4 kg



STIHL

Item Code	Bishops Code
4140 200 0566	75092048

FS 230 PROFESSIONAL BRUSHCUTTER – BIKE HANDLE

- Robust and powerful clearing saw for mowing with metal tools or a nylon mowing head
- Anti-vibration system
- Ergonomic bike handle ideal for working on large areas and allows the machine to be easily guided, thus reducing fatigue
- ElastoStart which reduces the shock caused by the compression of the engine during starting
- Multi-function handle puts all the engine controls at your fingertips, allowing easy and safe operation
- Compensator – controller in the carburettor prevents the fuel-air mixture getting richer as the air filter
- Tool free handle adjustment
- Standard cutter blade: Metal blade + AutoCut
- Displacement: 40.2cm³
- Power output: 1.55kW (2.2hp)
- Weight: 7.3kg



STIHL

Item Code	Bishops Code
4151 200 0004	75092058

FS 261 C-E BRUSHCUTTER – BIKE HANDLE

- Utilises the sheer power of Stihl 2-Mix technology to do the job with ease
- Low vibration and reduced fuel consumption round this tool off nicely for the operator
- Extremely balanced for its size
- Sits nicely by your side
- Metal blades can be attached to tackle thick shrubs, weeds and wood overgrowth
- The Stihl 2-Mix tech saves up to 20% on fuel and produces less emission into the environment when compared to an equivalent standard 2-stroke engine
- Tank volume: 750ml
- Idle speed: 2.800U/min
- Displacement: 41.6cc
- Power output: 2.0kW (2.7hp)
- Sound pressure level: 100db(A)
- Sound power level: 112db(A)
- Weight: 7.8kg



STIHL

Item Code	Bishops Code
4147 200 0496	75092060

FS 38 GRASS TRIMMER – LOOP HANDLE

- Powerful and durable
- Suitable for domestic trimming and lawn edging
- Loop handle is ideal for working in areas where space is limited
- Multi-function handle puts all the engine controls at your fingertips, allowing easy and safe operation
- Standard cutter blade: AutoCut C 5-2
- Displacement: 27.2cc
- Power output: 0.65kW (0.9hp)
- Weight: 4.1kg



STIHL

Item Code	Bishops Code
4140 012 2350	75092042

FS 45 GRASS TRIMMER – LOOP HANDLE

- Compact, powerful, lightweight and easy to handle
- Suitable for domestic trimming and lawn edging
- Loop handle is ideal for working in areas where space is limited
- Multi-function handle puts all the engine controls at your fingertips, allowing easy and safe operation
- Standard cutter blade: AutoCut C 5-2 Twin-Line Bump Feed
- Displacement: 27.2cc
- Power output: 0.75kW (1.0hp)
- Weight: 4.1kg



STIHL

Item Code	Bishops Code
4140 012 2351	75092044

22" LAWMOWER

- 22" Cut with side discharge
- 625E Series™ 190cc Briggs & Stratton engine
- Hand push
- Weight: 29kg



Bishops Code
75092006

21" LAWMOWER

- 21" Cut with catcher
- 750EX Series™ 161cc Briggs & Stratton engine
- Hand push
- Weight: 39kg



Item Code	Bishops Code
LM21	75092004

BG 56 BLOWER

- Blower with excellent power-to-weight ratio
- Quickly clears leaves and grass cuttings from any surface
- Supplied with a round nozzle
- STIHL 2-MIX engine
- Manual fuel pump (purger)
- Multi-function handle puts all the engine controls at your fingertips, allowing easy and safe operation
- Max. air throughput: 730m³/h
- Displacement: 27.2cc
- Weight: 4.2kg



Item Code	Bishops Code
4241 011 1761	75092076

GET MORE AT BISHOPS ▶

BACKPACK SPRAYER

Page 343



SHOVELS & RAKES

Page 239

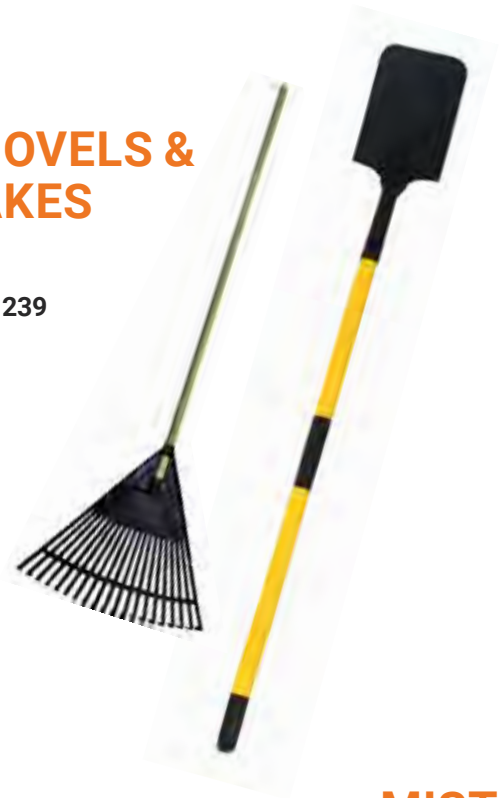

MIST BLOWER

Page 343





KING TONY

05

HAND & CUTTING TOOLS



TOOL STORAGE

Work Benches & Stations	158
Site, Tray & Truck Boxes	158-160
Tool Boxes, Chests, Cabinets & Trolleys	160-161
Tool Bags, Belts & Trays	162

TOOL KITS

Tool Bag & Box Kits	163-164
Tool Chest, Cabinet & Trolley Kits	164-165

SOCKETS & ACCESSORIES

Impact Socket Sets	166-167
Impact Sockets	168-171
Impact Socket Adaptors & Joints	171
Tool & Socket Kits	172
Socket & Ratchet Sets	173-178
Chrome Socket Sets	179
Chrome Sockets	180-183
Specialty Chrome Sockets & Sets	183-186
Socket Ratchets & Handles	187-188
Joints, Adaptors & Bit Holders	189
Socket & Torque Wrenches	190-191

HAND TOOLS

Spanner Sets	192-194
Spanners	195-197
Slogging Spanners & Adjustable Wrenches	197-198
Pipe, Chain, Strap & Drum Wrenches	198-199
Pliers Sets	200-201
Combination, Linesman & Long Nose Pliers	201-202
Fencing & Circlip Pliers	202-203
Multi-Grip, Slip Joint & Locking Pliers	203-204
Clamps	204-205
Cutting Pliers	207
Wire Crimping, Cutting & Stripping Pliers	208
Scissors & Snips	208-209
Bolt & Cable Cutters	209-210
Tube & Pipe Cutters	210-212
Flaring Tools & Puller/Separators	212
Socket Extractors & Spring Compressor Sets	213
Crowbars, Pry & Wrecking Bars	214-215
Podger Bars & Pins	215
Chisels & Sets	216
Punches & Sets	216-219
Hand Files & Sets	220

Claw & Ball Pein Hammers	222-223
Club, Sledge & Deadblow Hammers	224-225
Soft Face Hammers & Mallets	225-226
Hand Saws	227
Utility Knives & Cutters	228
Scrapers & Multi-Tools	229
Screwdriver Sets	230-231
Screwdrivers	232
Hex Keys & Sets	233-235
Drill Chucks & Arbors	236
Power Tool Bits & Nutsetters	236-237
Riveters & Staplers	238
Shovels & Gardening Tools	239
Inspection Mirrors & Pick-Up Tools	240
Hooks & Picks	240

MEASURING TOOLS

Rulers	241
Tape Measures	241-242
Spirit Levels & Plumb Bobs	242
Laser Measuring & Thermometers	243-244
Vernier & Spring Calipers & Dividers	245-246
Dial Gauges & Stands	246
Micrometers	247
Gauges, Scribes & Squares	248-250

CUTTING & DRILLING TOOLS

Saw Blades	251-254
Carbide Burrs	254-255
Jobber Drills & Sets	258-260
Reduced Shank & Taper Drills	260-261
Reduction Sleeves	261
Masonry Drills	262
Step Drills	263
Centre Drills, Slot & Endmills	264
Reamers & Annular Cutters	264-265
Holesaws & Accessories	266
Lathe Tools & Screw Extractors	267

TAPPING & THREADING

Tapping Drills	267-270
Tap Wrenches & Die Holders	270
Button Dies & Die Nuts	271-272
Tap & Drill & Tap & Die Sets	272-273
Pipe Dies, Threaders & Thread Repair	274-275



WORK BENCHES & SITE TOOL BOXES

HAND & CUTTING TOOLS

MOD SERIES INDUSTRIAL WORK STATIONS

- Heavy duty professional quality
- Rigid, sturdy and stable
- Bench top made from 3mm steel plate (800kg load capacity)
- All drawers are fitted with ball bearing slides
- Powder coated blue chassis with black top
- Lockable cabinets come with two adjustable shelves
- Suitable for tool rooms, workshops and warehouse counters
- Ideal for mechanics, engineers and tool makers
- 1,800(w) x 750(d) x 900(h)mm



61072970



61072975



61072980

Item Code	Description	Bishops Code
MOD 1	Work Bench	61072970
MOD 2	Work Bench With Lockable Cabinet & Single Drawer	61072975
MOD 3	Work Bench With Two Drawers	61072980

WORKBENCH PLUS 3 DRAWER CHEST & WALL CABINETS



- Ball bearing slide
- 2 x wall cabinets
- 3 drawer chest: 660(w) x 307(d) x 251(h)mm
- 2 drawer: 569(w) x 275(d) x 50(h)mm
- 1 drawer: 569(w) x 275(d) x 75(h)mm
- Wall cabinet: 400(w) x 200(d) x 500(h)mm
- Overall dimensions: 1,525(w) x 700(d) x 1,520(h)mm
- Weight: 104.2kg



Item Code	Bishops Code
87502	61072960

PLASTIC SITE BOXES



- Ideal for tradespeople and building sites
- Lockable latches
- Made from UV stabilised LLDPE (low linear density polyethylene) plastic
- Water and damp resistant when closed and sealed
- Side handles
- Heavy duty hinges
- Stackable



Item Code	Dimensions	Capacity	Bishops Code
TR55463336T	550(w) x 450(d) x 310(h)mm	60L	61072500
TR70464136T	720(w) x 450(d) x 430(h)mm	100L	61072502
TR90464436T	900(w) x 450(d) x 420(h)mm	140L	61072504
TR13046436T	1,300(w) x 450(d) x 450(h)mm	216L	61072508

PATROL BOXES

- Lightweight sheet metal construction
- Suitable for light duty applications
- Provides plenty of storage in a secure unit
- Can be locked by attaching a padlock to the front latch
- Side handles for ease of lifting



61572250

Description	Dimensions	Capacity	Bishops Code
Standard	500(w) x 300(d) x 250(h)mm	0.04m³	61572250
Standard	700(w) x 350(d) x 350(h)mm	0.09m³	61572300
Heavy Duty	900(w) x 500(d) x 500(h)mm	0.225m³	61572500

GET MORE AT BISHOPS



EXTENSION LEADS

Page 368

STEEL SITE BOX

- Durable powder-coat for long life
- Weatherproof design
- Sturdy piano hinges
- Forklift tong channel
- 1.2mm thick steel body
- 1.5mm thick steel lid
- 2 x gas struts
- 2 x hidden padlock recesses (bolt cutter proof)
- 2 x steel handles (hinged, flush mount)
- Dimensions: 1,030(l) x 600(w) x 640(h)mm



Item Code	Bishops Code
RLSIT1030	61072485

JOBSITE BOX

- Internal locking bar system
- Padlock fixing for security locks
- Round handles for easy and safe movement
- Waterproof and heavy duty
- Suitable for both indoor and outdoor use



Dimensions	Capacity	Bishops Code
1,270(w) x 640(d) x 775(h)mm	0.4392m ²	61072515

ALUMINIUM TOOL BOXES

- Made from 1.5mm aluminium checker plate and fully welded
- Riveted butt hinges
- Anti-rust plated chest handles
- 2 x gas struts
- Ideal for mobile service personnel, mining, agricultural industries and workshops
- 61072402 comes with hasp and staple suitable for padlock
- 61072405 and 61072412 come with flush key lock and 2 keys

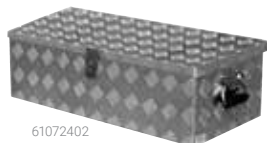

61072402



61072405



Item Code	Dimensions	Weight	Bishops Code
RLAL765	765(w) x 335(d) x 250(h)mm	5.6kg	61072402
RLAL1250	1,250(w) x 380(d) x 380(h)mm	12.6kg	61072405
AL1450	1,450(w) x 520(d) x 460(h)mm	18.4kg	61072412

UNDER TRAY UTE TOOL BOX

- Made from aluminium checker plate and fully welded
- Designed to fit on the back of work vehicles
- Flip-down door with rubber seal to protect from the elements
- Fitted with T-handle keyed lock
- Size: 750/520(w) x 225/270(d) x 440(h)mm
- Weight: 6.6kg



61072410



Item Code	Description	Bishops Code
UTB-L	Under Tray LHS Tool Box	61072410
UTB-R	Under Tray RHS Tool Box	61072415

LOW PROFILE ALUMINIUM BOXES

- Made from 2mm aluminium checker plate and fully welded
- Lower profile means more visibility from cabin
- Lid lifts almost to vertical position for easy access
- Fitted with gas struts
- Stainless steel concealed piano hinge
- Rubber seal helps keep dust and water out
- LP950 model features one T-handle keyed lock, the larger models have two
- 2 x gas struts



61072425

Dimensions	Weight	Bishops Code
1,250(w) x 600(d) x 500(h)mm	18.7kg	61072425
1,550(w) x 600(d) x 500(h)mm	27.3kg	61072430

ALUMINIUM ONE TONNER TOOL BOXES

- Made from 2mm aluminium checker plate and fully welded
- 2 x T-handles with keyed alike locks
- Rubber seal to help keep dust and water out
- Concealed stainless steel piano hinge
- 2 x gas struts
- Suits the back of utes and service vehicles
- Single shelf supplied with fasteners to be fitted by purchaser



61072400

Item Code	Dimensions	Weight	Bishops Code
AL1210	1,210(w) x 500(d) x 680(h)mm	25.0kg	61072400
AL1500	1,500(w) x 500(d) x 680(h)mm	30.0kg	61072401



TRUCK BOXES & TOOL BOXES

HAND & CUTTING TOOLS

STEEL TOOL TRUCK BOXES

- Ultra tough for harsh weather conditions
- Sealed bearing slide construction will take plenty of punishment
- Ideal for mobile service personnel, mining and agricultural industries
- Full height front door for added weather protection
- Huge capacity for mobile tradespersons
- Ideal for the back of vehicles
- Large drawers with sealed bearing slides (100kg rating)
- T-handle keyed locking mechanism
- Powder coated finish
- 2 x gas struts
- 4 x heavy duty handles
- The BKAT1770FD comes with fork lift points for easy transport
- Ripple white



61072434



61072436



61072438



61072440

Item Code	Description	Dimensions	Bishops Code
BKAT700FD	Two Drawers	700(l) x 600(d) x 750(h)mm	61072434
BKAT1210FD	Two Drawers	1,210(l) x 640(d) x 750(h)mm	61072436
BKAT1500FD	Two Drawers	1,500(l) x 600(d) x 750(h)mm	61072438
BKAT1770FD	Four Drawers	1,770(l) x 600(d) x 750(h)mm	61072440

PLASTIC TOOL BOX



- Multi-function box with extra space for tools and parts
- Lightweight durable design for tool storage
- Removable tool tray for small parts
- Lay-flat handle for easy stacking
- Dimensions: 445(l) x 240(w) x 206(h)mm
- Weight: 1.74kg
- Capacity: 22ltr



Item Code	Bishops Code
87407	61072130

UTILITY TOOL BOXES

- Lockable tool box
- Ideal for keeping in the work vehicle
- Handy and portable storage units for any tradesman



61072322

Size	Dimensions	Net Weight	Bishops Code
Small	410(w) x 154(d) x 95(h)mm	1.3kg	61072322
Medium	420(w) x 175(d) x 140(h)mm	1.6kg	61072325
Large	430(w) x 200(d) x 170(h)mm	2.2kg	61072330

CANTILEVER TOOL BOX

- 4 tray, cantilever style
- Provides plenty of storage in one compact unit
- Perfect for keeping in the work vehicle and transporting tools between work sites



Dimensions	Net Weight	Bishops Code
400(w) x 200(d) x 195(h)mm	3.3kg	61072340

ALUMINIUM TOOL BOX WITH HANDLE



- Made from 1.5mm aluminium checker plate and fully welded
- Convenient carry handle on top of lid
- 3 x 75mm butt hinges
- Suitable for mobile service personnel, mining, agricultural industries and workshops
- Built ultra tough
- Size: 580(w) x 245(d) x 210(h)mm
- Weight: 3.5kg



Item Code	Bishops Code
RLAL580	61072403

3 DRAWER SLIDE TYPE PORTABLE TOOL CHEST



- Heavy gauge steel
- Closing the cover synchronously locks all of the drawers
- Powder coating
- Drawer size: 504(w) x 195(d) x 52(h)mm
- Overall size: 535(w) x 220(d) x 290(h)mm
- Weight: 10.21kg



Item Code	Bishops Code
87401-3	61072520

6 DRAWER TOOL CHEST



- Heavy gauge steel
- Drawer slides type-ball bearing
- Grooved full width drawer pulls add strength and space to list contents of drawer
- Fold down locking system
- Powder coating finish
- With drawer liners and 4 bottom rubber mats
- Plastic drawer divider for chest (2 short divider + 2 long divider)
- Overall size: 660(w) x 307(d) x 374(h)mm
- Weight: 25.4kg



Item Code	Bishops Code
87411-6B	61072530

5 DRAWER BALL BEARING TYPE TOOL TROLLEY



- 26" roll-wagon (with bulk storage compartment)
- Frame constructed with one piece steel sheet for integral strength
- 4 industrial castors can be loaded 300kg grossly (size: 5" x 1 1/4")
- Useful tool tray/special side handle for easy moving tool trolley
- Grooved full width drawer pulls add strength and space to list contents of drawers
- Central locking system
- 10mm top mat
- Powder coating finish
- Overall size: 670(w) x 460(d) x 812(h)mm
- Weight: 56kg



Item Code	Bishops Code
87432-5G	61072580

EXTRA WIDE 7 DRAWER MOBILE TOOL CABINET



- Single piece steel frame for integral strength
- Side handle and lock castors for easy transportation
- Full width drawer pulls add strength
- Heavy duty ball bearing drawer slides and strong castors
- Includes rubber tray liner to protect tools and 10mm work mat on top surface
- Powder coated finish
- Dimensions: 1,070(w) x 460(d) x 980(h)mm
- Load Capacity: 600kg
- Weight: 129kg

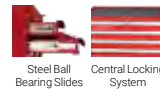

Item Code	Bishops Code
87439-7B	61073000

13 DRAWER TOOL CHEST TROLLEY



- 525 piece tool kit contents available separately
- Single piece steel frame for integral strength
- Side handle and lock castors for easy transportation
- Full width drawer pulls add strength
- Heavy duty ball bearing drawer slides and strong castors
- Includes rubber tray liner to protect tools and 10mm work mat on top surface
- Powder coated finish
- Load capacity: 600kg
- Dimensions: 1,358(w) x 460(d) x 980(h)
- Weight: 166kg

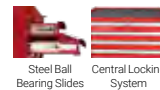

Item Code	Bishops Code
87435-13B	61073010

1 DRAWER BALL BEARING TYPE SHELF TROLLEY



- Two 88.9mm deep trays are positioned for convenience
- Cuff: 2.7kg
- Overall size: 716(w) x 410(d) x 750(h)mm
- Weight: 23.2kg



Item Code	Bishops Code
87441-1B	61072920



TOOL BAGS & PARTS TRAY

HAND & CUTTING TOOLS

FABRIC TOOL BOX

- Waterproof 1200D nylon oxford
- Light weight stainless bar and comfortable EVA handle
- Velcro cover for easy access and quickly take out tools
- Adjustable ambi-bag with soft padded shoulder strap
- 39 inner pockets for multiple-tools storage
- 50% lighter compared to metal box
- Overall size: 550(l) x 285(w) x 370(h)mm
- Weight: 3kg



Item Code
87711C

Bishops Code
61072105

ELECTRICIAN'S CANVAS TOOL BAGS

- Waterproof canvas construction with PVC base
- High-visibility reflective strip and piping
- Tools not included



61022040



61022050

Item Code	Description	Size	Bishops Code
91970062	Small	340 x 270 x 120mm	61022040
91970063	Medium	450 x 120 x 270mm	61022050
302907	Large	500 x 110 x 280mm	61022060

LEATHER NAIL BAG

- Made from split leather with rivet reinforced stress points
- Features two pockets for carrying a wide range of tools
- Fitted with adjustable 50mm webbing belt
- Fits waist up to 115cm



Item Code
11202

Bishops Code
62554300

ROUND MAGNETIC PARTS & TOOL HOLDER

- Stainless steel tray resists corrosion
- Can be used horizontally, vertically, and upside down
- Convenient for collecting small parts and tools
- 150mm diameter
- Weight: 4.3kg



Item Code
9TE11

Bishops Code
62080290

NAVIGATING & CHOOSING TOOL KITS

WITH SO MANY OPTIONS AND COMBINATIONS AVAILABLE, NAVIGATING THE RANGE OF TOOL KITS CAN BE DAUNTING.

Plus, we've only included the most commonly requested kits. There are hundreds of different configurations available at Bishops.

IT'S EASY AT BISHOPS!

To help you navigate, use this handy guide to understand the most common features of the tool kits and then look for these in the naming of the kit.

We've even laid them out in the order below throughout the catalogue in increasing size range, so you can work your way through the options in a logical order.

KEY FEATURES & ATTRIBUTES

TOOL BOXES

Small, lightweight and portable, but not at the expense of range. Cantilevered tool boxes pack the most into the smallest volume.



TOOL CHESTS

Tool chests offer a great combination of range and portability. Whatever the job, there's a tool chest to suit.



TOOL CABINETS

Tool cabinets are seriously big. Ideal for workshops or garages. Options include number of drawers and optional accessories such as side shelves.



TOOL CUPBOARDS

Suitable for wall mounting in workshops or similar environment. Comprehensive selections combined with tidy and visible organisation.



KING TONY

21 PIECE ELECTRICIAN'S TOOL KIT

- Comes with a variety of tools to suit electrician tradespeople, including 1,000V insulated hand tools

Includes:

- 1 x 1,000V Combination pliers – 210mm
- 1 x 1,000V Diagonal cutting pliers – 160mm
- 1 x 1,000V Long nose pliers – 160mm
- 1 x 1,000V Wire stripper – 160mm
- 1 x Terminals pliers – 220mm
- 2 x 1,000V Electrician screwdrivers – 4 x 125 & 6.5 x 150
- 2 x 1,000V Phillips screwdrivers – PH1 & PH2
- 5 x Electrician screwdrivers – 3 x 100, 4 x 125, 5.5 x 150, 6.5 x 150 & 8 x 175mm
- 1 x Voltage tester
- 1 x 1,000V Knife
- 1 x Stoning hammer – 1kg
- 1 x Electrician's scissors – 145mm
- 1 x Magnetic measuring tape – 5 x 25mm
- 1 x Hacksaw



Item Code	Bishops Code
69536	61074210

33 PIECE ELECTRICIAN'S TOOL KIT



Includes:

- 2 x Phillips screwdrivers – PH1 x 80mm, PH2 x 100mm
- 4 x Slotted screwdrivers – 5 x 75, 5 x 100, 6.5 x 100, 6.5 x 150mm
- 1 x VDE Insulated Phillips screwdriver – PH2 x 100mm
- 1 x VDE Insulated slotted screwdriver – 6.5 x 150mm
- 1 x 9 Piece ball hex key set – 1/16", 5/64", 3/32", 1/8", 5/32", 3/16", 1/4", 5/16" & 3/8"
- 1 x VDE Insulated combination pliers – 7 1/2"
- 1 x VDE Insulated diagonal cutting pliers – 6 1/2"
- 1 x VDE Insulated long nose pliers – 8 1/4"
- 1 x VDE Insulated wire stripping pliers – 6 1/4"
- 1 x Utility knife – 165mm
- 1 x Adjustable Wrench – 25mm
- 1 x Tape measure – 3m(10')
- 1 x Waterproof 600D Oxford fabric tool bag



Item Code	Bishops Code
91333MQ	61074460

43 PIECE MECHANICS TOOL BAG SET



- Soft case
- Tool bag size: 250(l) x 400(w) x 30(h)mm
- Weight: 2.5kg

Includes:

- 7 x 1/4" Hex size shank drivers (for Torx internal) – T10, T15, T20, T25, T27, T30 & T40
- 3 x 1/4" Hex size shank drivers (Pozidriv type) – PZ1, PZ2 & PZ3
- 4 x Phillips screwdrivers – PH0 x 60mm, PH1 x 100mm, PH2 x 38mm & PH2 x 150mm
- 3 x Slotted screwdrivers – 3.0 x 75mm, 6.5 x 38mm & 6.5 x 150mm
- 11 x 1/4" Drive 6 point metric standard sockets – 4, 5, 6, 7, 8, 9, 10, 11, 12, 13 & 14mm
- 7 Piece aluminium folding hex key wrench set
- 1 x 1/4" Drive bit holder
- 1 x 1/4" Drive driving handle (PP+TPR)
- 1 x 1/4" Drive universal joint
- 1 x Adjustable wrench
- 1 x European style combination pliers
- 1 x Groove joint pliers
- 1 x Tape measure
- 1 x 18mm Cutter with blades
- 1 x 1/4" Drive socket rail & clip
- 1 x 1/4" Drive socket rail clip



Item Code	Bishops Code
92543MR01	61074270

62 PIECE TOOL BOX KIT



- Tool box size: 470(l) x 220(w) x 255(h)mm
- Weight: 15.9kg

Includes:

- 7 piece metric combination wrench set
- 6 piece metric screwdriver set
- 3 piece European style combination pliers
- 6 piece 1/2" drive wrench set
- 20 piece 1/2" drive 6 point metric socket set
- 20 piece combination tool set



Item Code	Bishops Code
902-062MR	61074560

63 PIECE TOOL BOX KIT



- Tool box size: 470(l) x 220(w) x 260(h)mm
- Weight: 14kg

Includes:

- 10 x Combination wrenches – 8, 10, 12, 13, 14, 17, 19, 21, 22 & 24mm
- 9 x Ball hex keys (extra long arm) – 1.5, 2, 2.5, 3, 4, 5, 6, 8 & 10mm
- 3 x Phillips screwdrivers – PH1 x 80mm, PH2 x 38mm & PH3 x 150mm
- 3 x Slotted screwdrivers – 5.5 x 100mm, 6.5 x 38mm & 8 x 175mm
- 1 x Centre punch – Ø4 x 120mm
- 2 x Flat chisels – Ø17 x 150mm & Ø23 x 200mm
- 4 x Pin punches – Ø3 x 125mm, Ø4 x 150mm, Ø5 x 165mm & Ø6 x 180mm
- 1 x Adjustable wrench
- 1 x European style combination pliers
- 1 x European style line long nose pliers
- 1 x German style line groove joint pliers
- 1 x American style hammer
- 6 Piece 1/2" drive wrench set for tool box
- 20 piece 1/2" drive socket set metric 6 point for tool chest



Item Code	Bishops Code
902-164MR	61074570

68 PIECE TOOL BOX KIT



- Tool box size: 470(l) x 220(w) x 255(h)mm
- Weight: 15.9kg

Includes:

- 14 x Combination wrenches – 8, 10, 11, 12, 13, 14, 15, 16, 17, 18, 19, 21, 22 & 24mm
- 3 x Phillips screwdrivers – PH1 x 80mm, PH2 x 38mm & PH3 x 150mm
- 3 x Slotted screwdrivers – 5.5 x 100mm, 6.5 x 38mm & 8 x 175mm
- 1 x Centre punch – Ø4 x 120
- 2 x Flat chisels – Ø17 x 150mm & Ø23 x 200mm
- 4 x Pin punches – Ø3 x 40mm, Ø4 x 50mm, Ø5 x 55mm & Ø6 x 55mm
- 1 x Adjustable wrench
- 1 x European style combination pliers
- 1 x European style line long nose pliers
- 1 x Groove joint pliers
- 1 x German style hammer
- 1 x Hacksaw
- 1 x 6 Piece 1/2" drive wrench set
- 1 x 20 Piece 1/2" drive metric 6 point socket set



Item Code	Bishops Code
902-068MR	61074575



METRIC? IMPERIAL?

Unless otherwise specified in the product title, all tool kits displayed in this catalogue contain a mix of both metric and imperial tools.



77 PIECE TOOL BOX KIT



- Tool box size: 470(l) x 220(w) x 255(h)mm
- Weight: 27.4kg

Includes:

- 1 x 15 Piece metric combination wrench set
- 1 x 6 Piece metric screwdriver set
- 1 x 29 Piece 1/2" 12 point socket set
- 1 x 6 Piece 1/2" drive accessories
- 1 x 10 Piece 3/4" drive socket set
- 1 x 11 Piece pliers and hex key set



Item Code

908-077CR01

Bishops Code

61074302

109 PIECE TOOL BOX KIT



- Tool box size: 470(l) x 220(w) x 255(h)mm
- Weight: 25.5kg

Includes:

- 19 x Combination wrenches – 8, 9, 10, 11, 12, 13, 14, 15, 16, 17, 18, 19, 21, 22, 23, 24, 27, 30 & 32mm
- 9 x Ball hex keys (extra long arm) – 1.5, 2, 2.5, 3, 4, 5, 6, 8 & 10mm
- 7 x Star L-wrenches (standard type) – T10, T15, T20, T25, T27, T30 & T40
- 4 x Phillips screwdrivers – PH0 x 60mm, PH1 x 100mm, PH2 x 100mm & PH3 x 150mm
- 6 x Slotted screwdrivers – 3 x 75mm, 4 x 100mm, 5 x 75mm, 5.5 x 125mm, 6.5 x 150mm & 8 x 175mm
- 2 x Flat chisels – Ø20 x 175mm & Ø26 x 300mm
- 8 x Pin punches – Ø2 x 115mm, Ø3 x 125mm, Ø4 x 150mm, Ø5 x 165mm, Ø6 x 180mm, Ø8 x 200mm, Ø12 x 230mm & Ø14 x 250mm
- 1 x Hacksaw
- 6 Piece 1/2" drive wrench set for tool box
- 20 Piece 1/2" drive socket set metric 6 point for tool chest
- 6 Piece flare nut wrench set
- 12 Piece angled socket wrench set
- 1 x European style combination pliers
- 1 x European style heavy duty diagonal cutting nippers
- 1 x European style line long nose pliers
- 1 x European style line end cutting pliers
- 1 x German style line groove joint pliers
- 1 x American style hammer
- 1 x Tape measure
- 1 x Adjustable wrench
- 1 x Lock-grip pliers



Item Code

902-109MR

Bishops Code

61074585

68 PIECE TOOL CHEST KIT



- Chest size: 535(l) x 220(w) x 290(h)mm
- Weight: 18.8kg

Includes:

- 1 x 3 drawer slide type portable tool chest
- 1 x 6 piece metric screwdriver set
- 1 x 38 piece 1/2" drive metric 6 point socket set with 1/2" drive 32 teeth reversible ratchet
- 1 x 4 piece European type pliers set
- 1 x 21 piece combination tool set



Item Code

901-068MR

Bishops Code

61074590

107 PIECE TOOL CHEST KIT



- Chest size: 660(w) x 307(d) x 374(h)mm
- Weight: 25.4kg

Includes:

- 1 x 6 Drawer chest
- 1 x 7 Piece ball hex key set
- 1 x 9 Piece ball hex key set
- 1 x 42 Piece 1/2" drive 12 point socket wrench set
- 1 x Ball peen hammer
- 1 x 6 Piece Phillips & slotted screwdriver set
- 1 x 4 Piece pliers set
- 1 x 38 Piece wrench set

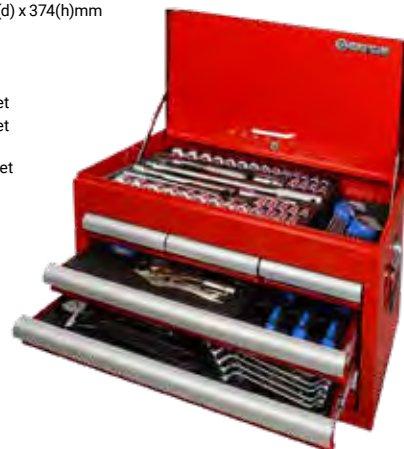

Item Code

911-002CR

Bishops Code

61074610

187 PIECE TOOL CHEST KIT



- Chest size: 660(w) x 307(d) x 374(h)mm
- Weight: 25.4kg

Includes:

- 1 x 6 Drawer chest
- 1 x 31 Piece combination wrench and hey key set
- 1 x 26 Piece combination wrench and hey key set
- 1 x 45 Piece combination wrench and screwdrivers set
- 1 x European type straight internal circlip pliers – 180mm
- 1 x European type straight external circlip pliers – 180mm
- 1 x Locking curved jaw grip pliers – 225mm
- 1 x European type combination pliers – 213mm
- 1 x European type heavy duty diagonal cutting nippers – 200mm
- 1 x European type line long nose pliers – 200mm
- 1 x Ball peen hammer
- 1 x Tape measure – 5m(16ft)



Item Code

911-004CRV

Bishops Code

61074625

219 PIECE TOOL CHEST KIT



- Chest size: 660(w) x 307(d) x 374(h)mm
- Weight: 48.1kg
- Includes:**
- 1 x 6 Drawer tool chest (87411-6B)
- 1 x 48 Piece 1/4" drive 6 point socket set
- 1 x 70 Piece 1/2" & 3/8" drive 12 point socket set
- 1 x 28 Piece wrench, punch & hammer set
- 1 x 29 Piece screwdriver, plier & hex key set
- 1 x Hacksaw
- 1 x 2 Piece pliers set
- 1 x 4 Piece circlip pliers set
- 1 x 38 Piece wrench set



Item Code	Bishops Code
911-000CR	61074630

173 PIECE TOOL TROLLEY KIT



- Trolley size: 670(w) x 460(d) x 812(h)mm
- Weight (inc contents): 80.7kg
- Includes:**
- 1 x 5 Drawer ball bearing type tool trolley
- 1 x 6 Piece pin punch set
- 1 x 16 Piece metric combination wrench set
- 1 x 11 Piece 75° offset box end wrench set
- 1 x 8 Piece L-handle ball point hex key set
- 1 x 8 Piece Torx key set
- 1 x 10 Piece metric screwdriver set
- 1 x 7 Piece pliers set
- 1 x 33 Piece 1/2" drive metric 6pt socket set
- 1 x 40 Piece 1/4" & 1/2" drive socket wrench set
- 1 x 3 Piece combination tool set
- 1 x 31 Piece combination tool set



Item Code	Bishops Code
932-003MR01A	61074655

234 PIECE 6 DRAWER TOOL CHEST KIT



- Chest size : 660(l) x 307(w) x 374(h)mm
- All sets supplied in tool chest ready trays
- Includes:**
- 1 x 48 Piece 1/4" Drive 6pt socket set
- 1 x 2 Piece pliers set
- 1 x 4 Piece circlip pliers set
- 1 x 78 Piece 3/8" & 1/2" drive socket set
- 1 x 53 Piece hex key, snips, bit & striking tool set
- 1 x 20 Piece screwdriver, pliers & bit socket set
- 1 x 29 Piece combination wrench set



Item Code	Bishops Code
911-003CR01	61074633

306 PIECE 5 DRAWER TOOL CHEST KIT



- 5 drawer, extra deep tool box with EVA foam inserts
- Heavy duty ball bearing drawer slides
- Rubber tray liners to protect tools
- Fully lockable with smooth push-in lock
- Dimensions: 660(l) x 455(w) x 483(h)mm
- Includes:**
- 1 x 5 Drawer tool chest
- 1 x Tape measure – 8m(26ft)
- 1 x Hacksaw – 300mm
- 1 x 20 Piece combination wrench set
- 1 x 24 Piece combination wrench set
- 1 x 10 Piece screwdriver set
- 1 x 103 Piece 1/4", 3/8" & 1/2" Drive socket wrench set
- 1 x 17 Piece pliers, punch & hammer set
- 1 x 40 Piece 1/4", 3/8" & 1/2" Drive socket wrench set
- 1 x 90 Piece wrench, bit & hex key set



Item Code	Bishops Code
919-306CRVB	61074635

GET MORE AT BISHOPS

STEEL CAP BOOTS

From Page 84



170 PIECE MOBILE CABINET KIT



- Overall size: 670(w) x 460(d) x 1,186(h)mm
- Weight: 106.2kg
- Includes:**
- 1 x 6 Drawer chest
- 1 x 5 Drawer tool trolley
- 1 x 16 Piece metric combination wrench set
- 1 x 3 Piece 15° flare nut wrench set
- 1 x 11 Piece 75° offset box end wrench set
- 1 x 10 Piece extra long ball point hex key set
- 1 x 8 Piece L-handle torx hex key set
- 1 x 26 Piece 1/4" drive socket set metric
- 1 x 22 Piece 3/8" drive 12 point metric socket set
- 1 x 24 Piece 1/2" drive 12 point metric socket set
- 1 x 3 Piece European type combination pliers set
- 1 x 9 Piece 1/2" drive torx bit socket set
- 1 x 9 Piece 1/2" drive hex bit socket set
- 1 x 10 Piece 1/2" drive impact driver set
- 1 x 3 Piece combination tool set
- 1 x 6 Piece screwdriver set metric
- 1 x 10 Piece punch set
- 2 x Lock modules



Item Code	Bishops Code
941-101MR	61074660



A GUIDE TO SOCKETS

**IMPACT SOCKETS OR STANDARD SOCKETS?
SO MANY OPTIONS TO CHOOSE FROM –
FIND THEM AT BISHOPS!**



IMPACT SOCKETS

Use impact sockets with powered impact tools such as electric or pneumatic wrenches. These sockets have thick walls and a phosphate sunk finish that will not crack or flake off under repeated stress. Impact sockets are heat treated to a low hardness and optimised for impact resistance.

CHROME SOCKETS

Chrome sockets are suitable for use with hand tools. They have thinner walls for better clearance. Chrome sockets are heat treated to a higher hardness for increased strength. Do not use chrome sockets with powered impact tools! You run the risk of injury and delayed or damaged work.



SOCKET SETS

Impact socket sets include a range of different socket sizes to prepare you for any job. Chrome socket sets typically include a ratcheting socket wrench and other accessories to help with accessibility, such as universal joints or extensions.



8 PIECE 1/2" DRIVE IMPACT SOCKET SET – METRIC



- 6 points, standard length
- Metal case size: 270(l) x 73(w) x 46(h)mm
- Weight: 1.3kg

Includes:

- Sizes: 10, 12, 13, 14, 17, 19, 21 & 24mm



Item Code

4408MP

Bishops Code

76252308

8 PIECE 1/2" DRIVE IMPACT SOCKET SET – IMPERIAL



- Metal case size: 270(l) x 73(w) x 46(h)mm
- Weight: 1.3kg

Includes:

- Sizes: 3/8", 7/16", 1/2", 9/16", 11/16", 3/4", 13/16" & 15/16"



Item Code

4408SP

Bishops Code

76252108

14 PIECE 1/2" DRIVE IMPACT SOCKET SET – IMPERIAL



- 6 points, standard length
- Metal case size: 270(l) x 100(w) x 49(h)mm
- Weight: 2.4kg

Includes:

- Sizes: 3/8", 7/16", 1/2", 9/16", 5/8", 11/16", 3/4", 13/16", 7/8", 15/16", 1", 1 1/16", 1 1/8" & 1 1/4"



Item Code

4414SP

Bishops Code

76252115

15 PIECE 1/2" DRIVE IMPACT SOCKET SET – METRIC



- 6 points, deep version
- Chrome molybdenum alloy steel
- Phosphate sunk finishing
- Metal case size: 445(l) x 135(w) x 50(h)mm
- Weight: 4.9kg

Includes:

- Sizes: 10, 11, 12, 13, 14, 15, 16, 17, 18, 19, 21, 24, 26, 29 & 32mm



Item Code

4415MP

Bishops Code

76252315

SOCKET SETS – EASY ID

Impact socket sets are available in metric and imperial.
King Tony socket sets are easily recognised by their colour.



Metric sizes are always highlighted in blue.

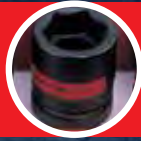

Imperial sizes are always highlighted in red.



GET MORE AT BISHOPS



PNEUMATIC IMPACT WRENCHES

From Page 147

8 PIECE 3/4" DRIVE IMPACT SOCKET SET – METRIC



- 6 point, Standard length
 - Material: Chrome molybdenum alloy steel
 - Phosphate sunk finish
- Includes:**
- Sizes: 21, 22, 24, 27, 30, 32, 36 & 41mm



Item Code

6409MP03

Bishops Code

76260308

11 PIECE 3/4" DRIVE BIT IMPACT SOCKET SET – METRIC



- Chrome molybdenum alloy steel
 - Phosphate sunk finishing
 - Metal case size: 270(l) x 100(w) x 49(h)mm
 - Weight: 1.5kg
- Includes:**

- 4 x 3/4" Drive impact hex bits – 10, 12, 14 & 17mm
- 5 x 3/4" Drive impact hex bits – 19, 22, 24, 27 & 32mm
- 1 x 3/4" Drive impact bit holder
- 1 x 3/4" Drive impact bit holder



Item Code

6411MP

Bishops Code

61006115

8 PIECE 3/4" DRIVE IMPACT SOCKET SET – METRIC



- 6 points, standard/lightweight type
 - Chrome molybdenum alloy steel
 - Phosphate sunk finishing
 - Metal case size: 241(l) x 124(w) x 68(h)mm
 - Weight: 3.9kg
- Includes:**
- Sizes: 19, 22, 24, 27, 30, 32, 36 & 38mm



Item Code

6408MP

Bishops Code

76260306

8 PIECE 1" DRIVE IMPACT SOCKET SET – METRIC



- 6 points, standard length
 - Chrome molybdenum alloy steel
 - Phosphate sunk finishing
 - Metal case size: 280(l) x 130(w) x 74(h)mm
 - Weight: 6.4kg
- Includes:**
- Sizes: 24, 27, 30, 32, 33, 36, 38 & 41mm



Item Code

8410MP

Bishops Code

76268308

8 PIECE 3/4" DRIVE IMPACT SOCKET SET – IMPERIAL



- 6 points, standard/lightweight type
 - Chrome molybdenum alloy steel
 - Phosphate sunk finishing
 - Metal case size: 241(l) x 124(w) x 68(h)mm
 - Weight: 3.5kg
- Includes:**
- Sizes: 3/8", 7/8", 15/16", 1 1/16", 1 3/16", 1 1/4", 1 7/16" & 1 1/2"



Item Code

6408SP10

Bishops Code

76260108

8 PIECE 1" DRIVE IMPACT SOCKET SET – IMPERIAL



- 6 points, standard length
 - Chrome molybdenum alloy steel
 - Phosphate sunk finishing
 - Metal case size: 280(l) x 130(w) x 74(h)mm
 - Weight: 6.4kg
- Includes:**
- Sizes: 15/16", 1 1/16", 1 3/16", 1 1/4", 1 7/16", 1 7/8", 1 1/2" & 1 5/8"



Item Code

8410SP

Bishops Code

76268108



1/2" IMPACT SOCKETS

HAND & CUTTING TOOLS

1/2" DRIVE STANDARD IMPACT SOCKETS – METRIC

- Chrome molybdenum alloy steel
- Phosphate sunk finishing
- Thin walled design on square driving side
- DIN 3129, ISO2725-2

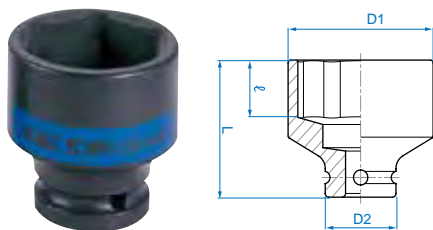

Item Code	Size	D1	D2	ℓ	Length	Weight	Bishops Code
453508M	8mm	14mm	25mm	7mm	38mm	67g	76247008
453509M	9mm	15mm	25mm	7mm	38mm	67g	76247009
453510M	10mm	17mm	25mm	8mm	38mm	70g	76247010
453511M	11mm	18mm	25mm	8mm	38mm	71g	76247011
453512M	12mm	19mm	25mm	9mm	38mm	72g	76247012
453513M	13mm	20mm	25mm	10mm	38mm	72g	76247013
453514M	14mm	22mm	25mm	10mm	38mm	77g	76247014
453515M	15mm	23mm	30mm	11mm	38mm	112g	76247015
453516M	16mm	24mm	30mm	11mm	38mm	112g	76247016
453517M	17mm	26mm	30mm	12mm	38mm	115g	76247017
453518M	18mm	27mm	30mm	13mm	38mm	115g	76247018
453519M	19mm	28mm	30mm	13mm	38mm	120g	76247019
453521M	21mm	30mm	30mm	14mm	40mm	125g	76247021
453522M	22mm	32mm	30mm	14mm	40mm	143g	76247022
453523M	23mm	33mm	30mm	15mm	40mm	143g	76247023
453524M	24mm	34mm	30mm	15mm	42mm	152g	76247024
453525M	25mm	36mm	30mm	15mm	42mm	168g	76247025
453526M	26mm	37mm	30mm	15mm	42mm	173g	76247026
453527M	27mm	38mm	30mm	16mm	44mm	176g	76247027
453528M	28mm	41mm	30mm	16mm	44mm	194g	76247028
453529M	29mm	41mm	30mm	17mm	44mm	194g	76247029
453530M	30mm	42mm	30.5mm	17mm	44mm	201g	76247030
453532M	32mm	46mm	30mm	19mm	44mm	205g	76247032

1/2" DRIVE STANDARD IMPACT SOCKETS – IMPERIAL

- Chrome molybdenum alloy steel
- Phosphate sunk finishing
- Thin walled design on square driving side
- ANSI/ASME B107.2

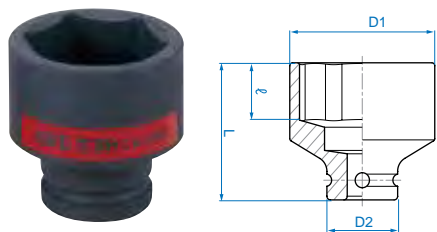

Item Code	Size	D1	D2	ℓ	Length	Weight	Bishops Code
453510S	5/16"	14mm	25mm	7mm	38mm	67g	76246031
453512S	3/8"	17mm	25mm	7mm	38mm	70g	76246037
453514S	7/16"	18mm	25mm	8mm	38mm	71g	76246043
453516S	1/2"	20mm	25mm	10mm	38mm	72g	76246050
453518S	9/16"	22mm	25mm	10mm	38mm	77g	76246056
453520S	5/8"	24mm	25mm	11mm	38mm	112g	76246062
453522S	11/16"	26mm	30mm	12mm	38mm	115g	76246068
453524S	3/4"	28mm	30mm	13mm	38mm	120g	76246075
453526S	13/16"	30mm	30mm	14mm	40mm	125g	76246081
453528S	7/8"	32mm	30mm	14mm	40mm	143g	76246087
453530S	15/16"	34mm	30mm	15mm	42mm	152g	76246093
453532S	1"	36mm	30mm	15mm	42mm	168g	76246100
453534S	1 1/16"	38mm	30mm	16mm	44mm	176g	76246106
453536S	1 1/8"	41mm	30mm	17mm	44mm	194g	76246112
453538S	1 3/16"	42mm	30.5mm	17mm	44mm	201g	76246118
453540S	1 1/4"	46mm	30mm	18mm	44mm	205g	76246125



1/2" DRIVE DEEP IMPACT SOCKETS – METRIC

- Chrome molybdenum alloy steel
- Phosphate sunk finishing
- Thin walled design on square driving side
- DIN 3121



Item Code	Size	D1	D2	ℓ	Length	Weight	Bishops Code
443508M	8mm	14mm	25mm	12mm	78mm	116g	76247508
443510M	10mm	17mm	25mm	12mm	80mm	136g	76247510
443511M	11mm	18mm	25mm	13mm	80mm	144g	76247511
443512M	12mm	19mm	25mm	14mm	80mm	157g	76247512
443513M	13mm	20mm	25mm	14mm	80mm	157g	76247513
443514M	14mm	22mm	25mm	14mm	80mm	172g	76247514
443515M	15mm	23mm	30mm	16mm	80mm	223g	76247515
443516M	16mm	24mm	30mm	16mm	80mm	230g	76247516
443517M	17mm	26mm	30mm	16mm	80mm	240g	76247517
443518M	18mm	27mm	30mm	17mm	80mm	255g	76247518
443519M	19mm	28mm	30mm	18mm	80mm	236g	76247519
443521M	21mm	30mm	30mm	20mm	80mm	240g	76247521
443522M	22mm	32mm	30mm	22mm	80mm	296g	76247522
443523M	23mm	33mm	30mm	24mm	80mm	300g	76247523
443524M	24mm	34mm	30mm	24mm	80mm	308g	76247524
443525M	25mm	36mm	30mm	24mm	80mm	342g	76247525
443526M	26mm	37mm	30mm	27mm	80mm	344g	76247526
443527M	27mm	38mm	30mm	27mm	80mm	356g	76247527
443529M	29mm	41mm	30mm	27mm	80mm	404g	76247529
443530M	30mm	42mm	30.5mm	30mm	80mm	416g	76247530
443532M	32mm	46mm	30mm	32mm	80mm	510g	76247532
443536M	36mm	47mm	30mm	36mm	80mm	556g	76247536

1/2" DRIVE DEEP IMPACT SOCKETS – IMPERIAL

- Chrome molybdenum alloy steel
- Phosphate sunk finish
- Thin walled design on square driving side
- ANSI/ASME B107.2



Item Code	Size	D1	D2	ℓ	Length	Weight	Bishops Code
443516S	1/2"	20mm	25mm	14mm	80mm	159g	76246550
443518S	9/16"	22mm	25mm	14mm	80mm	170g	76246556
443520S	5/8"	24mm	25mm	14mm	80mm	232g	76246562
443522S	11/16"	26mm	30mm	16mm	80mm	235g	76246568
443524S	3/4"	28mm	30mm	18mm	80mm	251g	76246575
443526S	13/16"	30mm	30mm	20mm	80mm	243g	76246581
443528S	7/8"	32mm	30mm	22mm	80mm	292g	76246587
443530S	15/16"	34mm	30mm	24mm	80mm	308g	76246593
443532S	1"	36mm	30mm	24mm	80mm	336g	76246600
443536S	1 1/8"	41mm	30mm	27mm	80mm	401g	76246612
443540S	1 1/4"	46mm	30mm	32mm	80mm	423g	76246625



3/4" DRIVE STANDARD IMPACT SOCKETS - METRIC



- Chrome molybdenum alloy steel
- Phosphate sunk finishing
- Thin walled design on square driving side
- DIN 3129

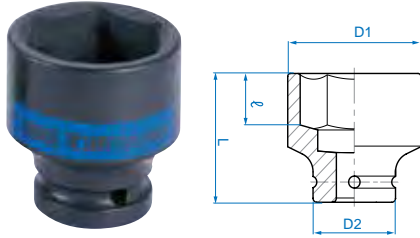

Item Code	Size	D1	D2	ℓ	Length	Weight	Bishops Code
653517M	17mm	29mm	44mm	10mm	50mm	316g	76255017
653519M	19mm	32mm	44mm	10mm	50mm	329g	76255019
653521M	21mm	35mm	44mm	13mm	50mm	341g	76255021
653522M	22mm	36mm	44mm	13mm	50mm	346g	76255022
653523M	23mm	37mm	44mm	15mm	50mm	350g	76255023
653524M	24mm	38mm	44mm	15mm	50mm	352g	76255024
653526M	26mm	40mm	44mm	15mm	53mm	358g	76255026
653527M	27mm	42mm	44mm	18mm	53mm	380g	76255027
653528M	28mm	44mm	44mm	18mm	53mm	394g	76255028
653530M	30mm	46mm	44mm	20mm	53mm	412g	76255030
653532M	32mm	48mm	44mm	20mm	57mm	460g	76255032
653533M	33mm	50mm	44mm	20mm	57mm	479g	76255033
653534M	34mm	51mm	44mm	22mm	57mm	491g	76255034
653535M	35mm	52mm	44mm	22mm	57mm	497g	76255035
653536M	36mm	53mm	44mm	22mm	57mm	519g	76255036
653538M	38mm	56mm	44mm	22mm	57mm	540g	76255038
653541M	41mm	59mm	44mm	24mm	58mm	580g	76255041
653542M	42mm	61mm	44mm	24mm	58mm	616g	76255042
653543M	43mm	62mm	44mm	24mm	58mm	636g	76255043
653546M	46mm	66mm	44mm	24mm	62mm	717g	76255046
653550M	50mm	71mm	54mm	26mm	65mm	955g	76255050

3/4" DRIVE IMPACT STANDARD SOCKETS - IMPERIAL



- Chrome molybdenum alloy steel
- Phosphate sunk finishing
- Thin walled design on square driving side
- ANSI/ASME B107.2

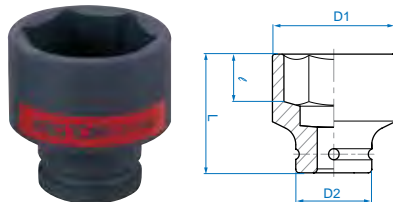

Item Code	Size	D1	D2	ℓ	Length	Weight	Bishops Code
653522S	11/16"	29mm	38mm	10mm	50mm	225g	76254068
653524S	3/4"	32mm	38mm	10mm	50mm	238g	76254075
653526S	13/16"	35mm	38mm	13mm	50mm	252g	76254081
653528S	7/8"	36mm	38mm	13mm	50mm	257g	76254087
653530S	15/16"	37mm	38mm	15mm	50mm	288g	76254093
651532S	1"	38mm	38mm	15mm	53mm	320g	76254100
653534S	11/16"	42mm	40mm	18mm	53mm	325g	76254106
653536S	1 1/8"	44.7mm	40mm	18mm	53mm	355g	76254112
653538S	1 3/16"	46mm	40mm	20mm	53mm	365g	76254118
653540S	1 1/4"	48mm	44mm	20mm	57mm	460g	76254125
653542S	1 5/16"	50mm	44mm	20mm	57mm	479g	76254131
653544S	1 3/8"	52mm	44mm	22mm	57mm	497g	76254137
653546S	1 7/16"	54mm	44mm	22mm	57mm	529g	76254143
653548S	1 1/2"	56mm	44mm	22mm	57mm	540g	76254150
653550S	1 9/16"	58mm	44mm	22mm	58mm	567g	76254156
653552S	1 5/8"	59mm	44mm	24mm	58mm	580g	76254162
653554S	1 11/16"	63.5mm	44mm	25mm	58mm	636g	76254168
653556S	1 3/4"	64mm	44mm	25mm	62mm	676g	76254175
653558S	1 13/16"	66mm	44mm	25.5mm	62mm	717g	76254181
653560S	1 7/8"	68mm	54mm	27mm	65mm	925g	76254187
653564S	2"	72mm	54mm	28mm	68mm	1.03kg	76254200
653568S	2 1/8"	76mm	54mm	30mm	68mm	1.12kg	76254212
653570S	2 3/16"	77mm	54mm	30.5mm	70mm	1.15kg	76254218
653572S	2 1/4"	79mm	54mm	32.5mm	70mm	1.20kg	76254225
653576S	2 3/8"	84mm	54mm	33.5mm	70mm	1.34kg	76254237

3/4" DRIVE DEEP IMPACT SOCKETS - METRIC



- Chrome molybdenum alloy steel
- Phosphate sunk finishing
- Thin walled design on square driving side
- DIN 3121

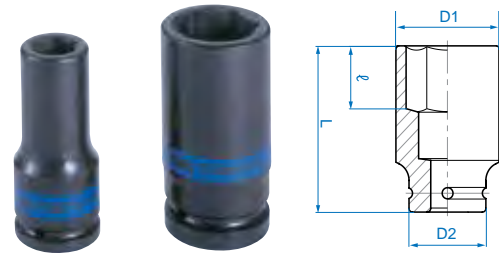

Item Code	Size	D1	D2	ℓ	Length	Weight	Bishops Code
643519M	19mm	32mm	44mm	16mm	90mm	558g	76255519
643521M	21mm	35mm	44mm	18mm	90mm	592g	76255521
643522M	22mm	36mm	44mm	18mm	90mm	607g	76255522
643523M	23mm	37mm	44mm	23mm	90mm	607g	76255523
643524M	24mm	38mm	44mm	23mm	90mm	626g	76255524
643525M	25mm	40mm	44mm	25mm	90mm	661g	76255525
643526M	26mm	40mm	44mm	25mm	90mm	623g	76255526
643527M	27mm	42mm	44mm	27mm	90mm	623g	76255527
643528M	28mm	44mm	44mm	27mm	90mm	670g	76255528
643530M	30mm	46mm	44mm	27mm	90mm	691g	76255530
643532M	32mm	48mm	44mm	30mm	90mm	728g	76255532
643533M	33mm	50mm	44mm	30mm	90mm	790g	76255533
643536M	36mm	53mm	44mm	32mm	90mm	809g	76255536
643538M	38mm	56mm	44mm	34mm	90mm	882g	76255538
643541M	41mm	59mm	44mm	34mm	90mm	938g	76255541
643544M	44mm	64mm	44mm	38mm	95mm	1.18kg	76255544
643546M	46mm	66mm	44mm	38mm	95mm	1.21kg	76255546
643550M	50mm	71mm	44mm	40mm	95mm	1.47kg	76255550

3/4" DRIVE DEEP IMPACT SOCKETS - IMPERIAL



- Chrome molybdenum alloy steel
- Phosphate sunk finishing
- Thin walled design on square driving side
- ANSI/ASME B107.2

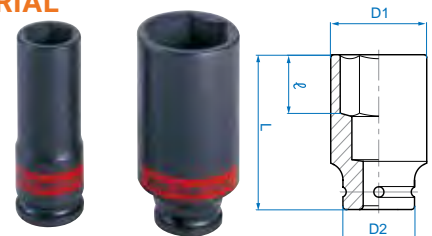

Item Code	Size	D1	D2	ℓ	Length	Weight	Bishops Code
643530S	15/16"	37mm	38mm	23mm	90mm	495g	76254593
643532S	1"	38mm	38mm	25mm	90mm	500g	76254595
643534S	1 1/16"	42mm	44mm	27mm	90mm	624g	76254606
643536S	1 1/8"	45mm	44mm	27mm	90mm	680g	76254612
643538S	1 3/16"	46mm	44mm	27mm	90mm	684g	76254618
643542S	1 5/16"	50mm	54mm	30mm	90mm	789g	76254631
643544S	1 3/8"	52mm	44mm	32mm	90mm	804g	76254637
643546S	1 7/16"	54mm	44mm	32mm	90mm	844g	76254643
643548S	1 1/2"	56mm	44mm	34mm	90mm	871g	76254650

GET MORE AT BISHOPS



CHROME SOCKETS

Page 182



1" IMPACT SOCKETS

1" DRIVE STANDARD IMPACT SOCKETS - METRIC



- Chrome molybdenum alloy steel
- Phosphate sunk finishing
- Thin walled design on square driving side
- DIN 3129, ISO 2725-2

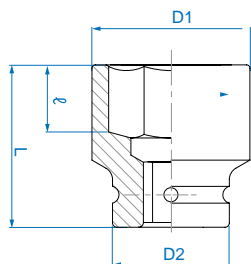

Item Code	Size	D1	D2	ℓ	Length	Weight	Bishops Code
853519M	19mm	35mm	54mm	15mm	58mm	508g	76263019
853521M	21mm	37mm	54mm	15mm	58mm	537g	76263021
853522M	22mm	38mm	54mm	15mm	58mm	520g	76263022
853524M	24mm	41mm	54mm	17mm	58mm	529g	76263024
853525M	25mm	42mm	54mm	17mm	58mm	562g	76263025
853527M	27mm	44mm	54mm	19mm	58mm	538g	76263027
853528M	28mm	45mm	54mm	19mm	58mm	538g	76263028
853530M	30mm	48mm	54mm	20mm	60mm	592g	76263030
853532M	32mm	51mm	54mm	20mm	62mm	679g	76263032
853533M	33mm	52mm	54mm	20mm	62mm	700g	76263033
853535M	35mm	54mm	54mm	20mm	62mm	779g	76263035
853536M	36mm	56mm	54mm	20mm	65mm	729g	76263036
853538M	38mm	58mm	54mm	22mm	65mm	742g	76263038
853541M	41mm	61mm	54mm	22mm	70mm	846g	76263041
853546M	46mm	68mm	54mm	26mm	75mm	1.07kg	76263046
853550M	50mm	73mm	54mm	26mm	75mm	1.10kg	76263050
853555M	55mm	79mm	54mm	32mm	83mm	1.43kg	76263055
853560M	60mm	86mm	54mm	32mm	87mm	1.75kg	76263060
853565M	65mm	92mm	54mm	34mm	90mm	1.75kg	76263065
853570M	70mm	97mm	54mm	34mm	93mm	2.11kg	76263070
853575M	75mm	104mm	86mm	36mm	95mm	3.18kg	76263075
853580M	80mm	110mm	86mm	43mm	95mm	3.35kg	76263080
853585M	85mm	115mm	86mm	43mm	95mm	3.25kg	76263085
853590M	90mm	122mm	86mm	43mm	100mm	3.95kg	76263090

1" DRIVE DEEP IMPACT SOCKETS - IMPERIAL



- Chrome molybdenum alloy steel
- Phosphate sunk finishing
- Thin walled design on square driving side
- ANSI/ASME B107.1

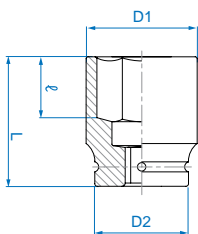

Item Code	Size	D1	D2	ℓ	Length	Weight	Bishops Code
843536S	1 1/8"	46.3mm	54mm	25mm	90mm	900g	76262612
843540S	1 1/4"	51mm	54mm	38mm	90mm	970g	76262625
843548S	1 1/2"	58mm	54mm	32mm	92mm	1.02kg	76262650
843550S	1 9/16"	60mm	54mm	32mm	92mm	1.07kg	76262656
843552S	1 5/8"	61mm	54mm	32mm	92mm	1.08kg	76262662
843556S	1 3/4"	67mm	54mm	32mm	92mm	1.12kg	76262675
843558S	1 13/16"	68mm	54mm	35mm	95mm	1.13kg	76262681
843560S	1 7/8"	70mm	54mm	35mm	95mm	1.4kg	76262687
843562S	1 15/16"	72mm	54mm	35mm	95mm	1.48kg	76262693
843564S	2"	74mm	54mm	35mm	95mm	1.57kg	76262700
843568S	2 1/8"	78mm	54mm	40mm	100mm	1.57kg	76262712
843570S	2 1/16"	79mm	54mm	40mm	100mm	1.86kg	76262718
843572S	2 1/4"	82mm	54mm	42mm	100mm	1.9kg	76262725

1" DRIVE STANDARD IMPACT SOCKETS - IMPERIAL



- Chrome molybdenum alloy steel
- Phosphate sunk finishing
- Thin walled design on square driving side
- ANSI/ASME B107.2

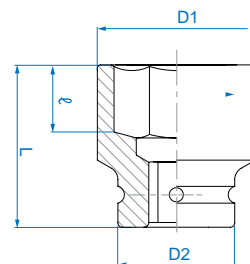

Item Code	Size	D1	D2	ℓ	Length	Weight	Bishops Code
853526S	1 1/16"	37mm	54mm	15mm	58mm	529g	76262081
853530S	1 5/16"	41mm	54mm	17mm	58mm	529g	76262093
853532S	1"	42mm	54mm	17mm	58mm	567g	76262100
853534S	1 1/16"	44mm	54mm	19mm	58mm	538g	76262106
853536S	1 1/8"	47mm	54mm	19mm	58mm	600g	76262112
853538S	1 3/16"	48mm	54mm	20mm	60mm	592g	76262118
853540S	1 1/4"	51mm	54mm	20mm	62mm	679g	76262125
853542S	1 5/16"	54mm	52mm	20mm	62mm	700g	76262131
853544S	1 3/8"	54mm	54mm	20mm	62mm	779g	76262137
853546S	1 7/16"	56mm	54mm	20mm	65mm	729g	76262143
853548S	1 1/2"	58mm	54mm	22mm	65mm	742g	76262150
853550S	1 9/16"	60mm	54mm	22mm	65mm	800g	76262156
643552S	1 5/8"	61mm	54mm	34mm	70mm	846g	76262162
853554S	1 11/16"	64mm	54mm	22mm	70mm	890g	76262168
853556S	1 3/4"	67mm	54mm	26mm	70mm	1.0kg	76262175
853558S	1 13/16"	68mm	54mm	26mm	75mm	1.07kg	76262181
643560S	1 7/8"	70mm	54mm	26mm	75mm	1.08kg	76262187
853562S	1 15/16"	72mm	54mm	26mm	75mm	1.14kg	76262193
853564S	2"	74mm	54mm	30mm	75mm	1.23kg	76262200
853566S	2 1/16"	75mm	54mm	30mm	80mm	1.3kg	76262206
853568S	2 1/8"	78mm	54mm	30mm	80mm	1.4kg	76262212
853570S	2 3/16"	79mm	54mm	32mm	83mm	1.43kg	76262218
853572S	2 1/4"	82mm	54mm	32mm	83mm	1.5kg	76262225
853574S	2 5/16"	83mm	54mm	32mm	83mm	1.54kg	76262231
853576S	2 3/8"	86mm	54mm	32mm	87mm	1.75kg	76262237
853578S	2 7/16"	88mm	54mm	34mm	87mm	1.76kg	76262243
853580S	2 1/2"	90mm	54mm	34mm	87mm	1.75kg	76262250
853582S	2 9/16"	92mm	54mm	34mm	90mm	1.75kg	76262256
853584S	2 5/8"	94mm	54mm	34mm	90mm	1.96kg	76262262
853588S	2 3/4"	97mm	54mm	34mm	93mm	2.11kg	76262275
853590S	2 11/16"	99mm	86mm	36mm	93mm	2.92kg	76262281
853592S	2 7/8"	102mm	86mm	36mm	93mm	3.05kg	76262287
853594S	2 15/16"	104mm	86mm	36mm	95mm	3.18kg	76262293
853596S	3"	106mm	86mm	36mm	95mm	3.20kg	76262300
8535AOS	3 1/8"	110mm	86mm	43mm	95mm	3.35kg	76262312

1" DRIVE DEEP IMPACT SOCKETS - METRIC



- Chrome molybdenum alloy steel
- Phosphate sunk finishing
- Thin walled design on square driving side
- DIN 3121

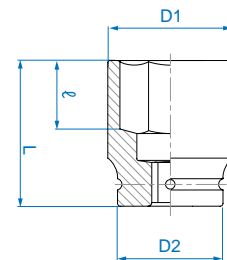

Item Code	Size	D1	D2	ℓ	Length	Weight	Bishops Code
843532M	32mm	51mm	54mm	28mm	90mm	970kg	76263432
843536M	36mm	56mm	54mm	32mm	92mm	1.03kg	76263436
843541M	41mm	61mm	54mm	32mm	92mm	1.08kg	76263441

1" DRIVE REAR WHEEL SOCKETS – METRIC

- Chrome molybdenum alloy steel
- Phosphate sunk finishing
- Length: 76mm
- DIN 3121

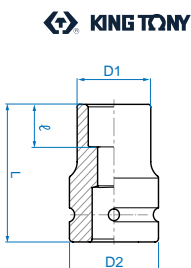

Item Code	Size	D1	D2	ℓ	Length	Weight	Bishops Code
853417M	17mm	38mm	54mm	23.5mm	76mm	628g	76264320
853419M	19mm	43mm	54mm	23.5mm	76mm	682g	76264330
853421M	21mm	47mm	54mm	23.5mm	76mm	733g	76264380

1½" DRIVE STANDARD IMPACT SOCKETS – METRIC

- Chrome molybdenum alloy steel
- Phosphate sunk finishing
- Thin walled design on square driving side
- DIN 3129

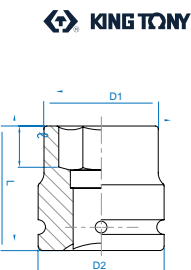

Item Code	Size	D1	D2	ℓ	Length	Weight	Bishops Code
953536M	36mm	62mm	86mm	26mm	80mm	1.994kg	76272036
953538M	38mm	64mm	86mm	26mm	80mm	2.001kg	76272038
953541M	41mm	68mm	86mm	28mm	80mm	2.056kg	76272041
953546M	46mm	73mm	86mm	30mm	85mm	2.451kg	76272046
953550M	50mm	78mm	86mm	32mm	85mm	2.246kg	76272050
953555M	55mm	85mm	86mm	36mm	93mm	2.52kg	76272055
953560M	60mm	90mm	86mm	40mm	95mm	2.757kg	76272060
953565M	65mm	96mm	86mm	42mm	100mm	3.134kg	76272065
953570M	70mm	103mm	86mm	46mm	103mm	3.529kg	76272070
953575M	75mm	108mm	86mm	48mm	105mm	3.713kg	76272075
953595M	95mm	134mm	127mm	50mm	110mm	7.224kg	76272095
9535A0M	100mm	140mm	127mm	53mm	115mm	7.729kg	76272100
9535A5M	105mm	146mm	127mm	53mm	115mm	7.856kg	76272105
9535B0M	110mm	152mm	127mm	56mm	125mm	8.845kg	76272111
9535B5M	115mm	160mm	127mm	60mm	125mm	9.454kg	76272115
9535C0M	120mm	166mm	127mm	62mm	130mm	9.96kg	76272120

1½" DRIVE STANDARD IMPACT SOCKETS – IMPERIAL

- Chrome molybdenum alloy steel
- Phosphate sunk finishing
- Thin walled design on square driving side
- DIN 3129

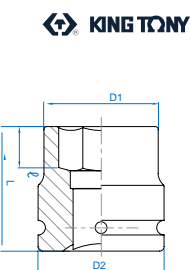

Item Code	Size	D1	D2	ℓ	Length	Weight	Bishops Code
953566S	2 1/16"	82mm	86mm	36mm	85mm	2.364kg	76273206
953568S	2 3/8"	84mm	86mm	36mm	90mm	2.508kg	76273212
953570S	2 3/16"	85mm	86mm	43mm	93mm	3.204kg	76273218
953572S	2 1/4"	87mm	86mm	43mm	93mm	5.209kg	76273225
953576S	2 3/8"	90mm	86mm	45mm	95mm	2.622kg	76273237
953578S	2 1/16"	93mm	86mm	44mm	95mm	2.711kg	76273243
953580S	2 1/2"	95mm	86mm	46mm	97mm	2.833kg	76273250
953582S	2 3/16"	96mm	86mm	49mm	100mm	2.863kg	76273256
953584S	2 5/8"	99mm	86mm	48mm	100mm	2.958kg	76273262
953586S	2 11/16"	101mm	86mm	48mm	100mm	3.055kg	76273275
953588S	2 3/4"	103mm	86mm	48mm	103mm	3.217kg	76273281
953590S	2 9/16"	105mm	86mm	50mm	105mm	3.306kg	76273287
953592S	2 7/8"	107mm	86mm	50mm	105mm	3.60kg	76273290
953594S	2 5/16"	108mm	86mm	50mm	105mm	3.455kg	76273295
953596S	3"	111mm	86mm	50mm	105mm	3.59kg	76273300

IMPACT UNIVERSAL JOINTS

- Chrome molybdenum alloy steel
- Phosphate sunk finishing
- DIN 3121



Item Code	Description	Length	Weight	Bishops Code
4797	½" Drive	65mm	0.172kg	76250580
6797	¾" Drive	114mm	0.742kg	76260520
6798P	¾" Drive with Ball	108mm	0.736kg	76260525
8797P	1" Drive with Ball	125mm	1.53kg	76266580

IMPACT ADAPTORS

- Chrome molybdenum alloy steel
- Phosphate sunk finishing
- DIN 3121



Item Code	Size	Weight	Bishops Code
4866	½" F x ¾" M	174g	76250510
6864	¾" F x ½" M	313g	76250520
6868	¾" F x 1" M	413g	76260540
8866	1" F x ¾" M	562g	76266520
8869P	1" F x 1½" M	963g	76266540

IMPACT EXTENSION BARS

- Chrome molybdenum alloy steel
- Phosphate sunk finishing
- Extension bar with ball
- DIN 3121



4260-03

Item Code	Size	Length	Weight	Bishops Code
4260-03	½" Drive	75mm	0.197kg	76250320
4260-05	½" Drive	125mm	0.277kg	76250350
4260-10	½" Drive	250mm	0.452kg	76250360
6260-07	¾" Drive	175mm	0.867kg	76260320
6260-10	¾" Drive	250mm	1.155kg	76260330
6260-13	¾" Drive	330mm	1.423kg	76260340
8260-07	1" Drive	175mm	1.393kg	76266320
8260-10	1" Drive	250mm	1.891kg	76266340
8260-13	1" Drive	330mm	2.455kg	76266360

10 PIECE ½" DRIVE IMPACT TORQUE EXTENSION SET

- Colour coded and engraved with Nm and ft.lb setting
- Helps to eliminate overtorqued lug nut
- Comes with handy wall mountable storage rack
- Max. torque ranges: 90–200Nm (65–150ft.lb)
- Overall length: 195mm



Item Code	Bishops Code
4481PP1	76252330



SOCKET TOOL KITS

HAND & CUTTING TOOLS

54 PIECE METRIC SOCKET & TOOL KIT KING TONY

- High density polyethylene case
- Case dimensions: 340(l) x 263(w) x 80(h)mm
- Weight: 3.85kg

Includes:

- 14 x 3/8" Drive 12 point standard sockets – 6, 7, 8, 9, 10, 11, 12, 13, 14, 15, 17, 18, 19 & 22mm
- 5 x 3/8" Drive 6 point deep sockets – 8, 10, 12, 13 & 14mm
- 2 x 3/8" Drive rubber spark plug sockets 16 & 21 point
- 2 x 3/8" Drive extension bars – 3" & 6"
- 7 x 3/16" Torx head bits – T10, T15, T20, T25, T30, T40, T45 & T50
- 7 x Combination spanners – 8, 10, 12, 13, 14, 17 & 19mm
- 7 x Ball hex keys – H1.5, H2, H2.5, H3, H4, H5 & H6mm
- 1 x Phillips screwdriver – PH2 x 100mm
- 1 x Slotted screwdriver – 5.5 x 100mm
- 1 x European style combination pliers
- 1 x 3/8" Drive 32 teeth reversible ratchet quick-release
- 1 x Bit holder
- 1 x Universal joint



Item Code	Bishops Code
3054MR	61074280

77 PIECE 1/4" & 1/2" DRIVE COMBINATION SOCKET SET KING TONY

- Case size: 475(l) x 360(w) x 90(h)mm
- Weight: 7.9kg

Includes:

- 5 x 1/4" Hex bits (hexagon head) – H3, H4, H5 & H6
- 3 x 1/4" Hex bits (Phillips head) – PH1, PH2 & PH3
- 4 x 1/4" Hex bits (slotted head) – 3, 4, 5 & 6mm
- 7 x 1/4" Hex bits (Torx head) – T10, T15, T20, T25, T27, T30 & T40
- 8 x Combination wrenches – 8, 10, 12, 13, 14, 15, 17 & 19mm
- 3 x Standard arm hex keys – 1.5, 2 & 2.5mm
- 3 x Phillips screwdrivers – PH1 x 80mm, PH2 x 100mm & PH3 x 150mm
- 2 x Slotted screwdrivers – 4 x 100mm & 6.5 x 100mm
- 4 x 1/4" Drive 12 point deep sockets – 8, 10, 12 & 13mm
- 9 x 1/4" Drive 12 point standard sockets – 4, 5, 6, 7, 8, 9, 10, 11 & 12mm
- 13 x 1/2" Drive 12 point standard sockets – 12, 13, 14, 15, 17, 18, 19, 21, 22, 24, 27, 30 & 32mm
- 1 x 1/4" Drive bit holder – 25mm
- 1 x 1/4" Drive driving handle – 150mm
- 1 x 1/4" Drive extension bar – 75mm
- 1 x 1/4" Drive flexible extension bar – 150mm
- 1 x 1/4" Drive sliding t-handle – 115mm
- 1 x 1/4" Drive 24 teeth reversible ratchet – 134mm
- 1 x 1/4" Drive universal joint
- 1 x 3/8"-1/2" Adaptor
- 2 x 1/2" Drive extension bar – 125 & 250mm
- 2 x 1/2" Drive 6 point spark plug sockets – 3/8" & 13/16"
- 1 x 1/2" Drive 32 teeth reversible ratchet – 262mm
- 1 x 1/2" Drive universal joint
- 1 x Combination pliers – 180mm
- 1 x Groove joint pliers – 253mm
- 1 x German-style hammer



Item Code	Bishops Code
7077MR	61074300

81 PIECE 1/4" & 1/2" DRIVE SOCKET & TOOL SET KING TONY

- 5 x 1/4" Hex Head Sockets – H3, H4, H5, H6 & H7
- 4 x 1/4" Torx Head Bits – T20, T25, T30 & T40
- 10 x Combinations Wrenches – 6, 7, 8, 10, 12, 13, 14, 15, 17 & 19
- 9 x Extra Long Arm Ball Hex Keys – H1.5, H2, H2.5, H3, H4, H5, H6, H8 & H10
- 7 x Star L-Wrenches – T10H, T15H, T20H, T25H, T27H, T30H & T40H
- 2 x Phillips Screwdrivers – PH1 x 80 & PH2 x 100
- 3 x Slotted Screwdrivers – 4 x 100mm, 5.5 x 125mm & 6.5 x 150mm
- 12 x 1/4" Drive 12pt Sockets – 4, 4.5, 5, 5.5, 6, 7, 8, 9, 10, 11, 12 & 13mm
- 10 x 1/2" Drive 6pt Sockets – 10, 11, 12, 13, 14, 15, 17, 19, 22 & 24mm
- 1 x 1/4" Drive extension bar
- 1 x 1/4" Drive 72 teeth mini bit holder ratchet
- 1 x 1/4" Drive universal joint
- 1 x 1/2" Drive extension bar – 125mm
- 2 x 1/2" Drive 12pt rubber spark plug sockets – 16 & 20.8mm
- 1 x 1/2" Drive 32 teeth quick-release reversible ratchet
- 1 x 1/2" Drive universal joint
- 1 x Combination pliers – 164mm
- 1 x Long nose pliers – 160mm
- 1 x Groove joint pliers – 253mm
- 1 x 1/4" Magnetic bit holder – 60mm
- 1 x Centre punch – 4mm
- 1 x Flat chisel – 15mm
- 1 x Pin punch – 4mm
- 1 x German style hammer
- 1 x 3W SMD LED pen light
- 1 x 6-24V Circuit tester



Item Code	Bishops Code
P7081MR	61074304

83 PIECE 1/4", 5/16" & 1/2" DRIVE COMBINATION SOCKET SET KING TONY

- Case size: 410(l) x 280(w) x 60(h)mm
- Weight: 4.96kg

Includes:

- 4 x 5/16" Hex size shank drivers (hexagon head) – H8, H10, H12 & H14
- 2 x 5/16" Hex size shank drivers (Phillips head) – PH3 & PH4
- 3 x 5/16" Hex size shank drivers (slotted head) – 8 x 1.2mm, 10 x 1.6mm & 12 x 2mm
- 4 x 5/16" Hex size shank drivers (for Torx) – T40, T45, T50 & T55
- 2 x 5/16" Hex size shank drivers (Pozidriv head) – PZ3 & PZ4
- 3 x 1/4" Drive slotted bit sockets – 4, 5.5 & 6.5mm
- 7 x 1/4" Drive Torx bit sockets – T8, T10, T15, T20, T25, T27 & T30
- 4 x 1/4" Drive hex bit sockets – H3, H4, H5 & H6
- 2 x 1/4" Drive Pozidriv bit sockets – PZ1 & PZ2
- 8 x Combination wrenches – 8, 10, 12, 13, 14, 15, 17 & 19mm
- 13 x 1/4" Drive 6 point metric standard sockets – 4, 4.5, 5, 5.5, 6, 7, 8, 9, 10, 11, 12, 13 & 14mm
- 12 x 1/2" Drive 6 point metric standard sockets – 14, 15, 16, 17, 18, 19, 20, 22, 24, 27, 30 & 32mm
- 1 x 1/4" Drive driving handle
- 1 x 1/4" Drive flexible extension bar
- 2 x 1/4" Drive extension bars – 55 & 100mm
- 1 x 1/4" Drive 24 teeth reversible ratchet
- 1 x 1/4" Drive universal joint
- 1 x 1/4" Drive socket adaptor – 25mm
- 1 x 1/2" Drive bit holder
- 1 x 1/2" Drive extension bar
- 2 x 1/2" Drive 6 point spark plug socket – 16 & 21mm
- 1 x 1/2" Drive 32 teeth reversible ratchet
- 1 x 1/2" Drive universal joint
- 1 x 3W LED pen light



Item Code	Bishops Code
7582MR	61074290

87 PIECE 1/4" & 1/2" DRIVE COMBINATION SOCKET SET



- Case size: 475(l) x 360(w) x 90(h)mm
- Weight: 9.2kg
- Includes:**
- 10 x Combination wrenches – 8, 10, 12, 13, 14, 15, 17, 18, 19 & 22mm
- 7 x Ball hex keys (long arm) – 2.5, 3, 4, 5, 6, 8 & 10mm
- 7 x Star L-wrenches (standard type) – T10, T15, T20, T25, T27, T30 & T40
- 2 x Phillips screwdrivers – PH1 x 80mm & PH2 x 100mm
- 2 x Slotted screwdrivers – 4 x 100mm & 5.5 x 100mm
- 6 x 10mm Hex size shank drivers (hexagon head) – H5, H6, H7, H8, H10 & H12
- 4 x 10mm Hex size shank drivers (spline head) – 6, 8, 10 & 12mm
- 6 x 10mm Hex size shank drivers (for Torx head) – T30, T40, T45, T50, T55 & T60
- 1 x Wheel nut wrench
- 5 x 1/4" Drive 12 point deep sockets – 7, 8, 10, 12 & 13mm
- 9 x 1/4" Drive 12 point standard sockets – 5, 5.5, 6, 7, 8, 10, 11, 12 & 13mm
- 14 x 1/2" Drive 12 point metric standard sockets – 10, 12, 13, 14, 15, 17, 18, 19, 21, 22, 24, 27, 30 & 32mm
- 1 x 1/4" Drive flexible extension bar
- 1 x 1/4" Drive sliding t-handle – 115mm
- 1 x 1/4" Drive 24 teeth reversible ratchet
- 1 x 1/4" Drive universal joint
- 1 x 1/2" Drive bit holder
- 1 x 1/2" Drive flexible handle
- 2 x 1/2" Drive 12 point spark plug socket – 5/8" & 13/16"
- 1 x 1/2" Drive 32 teeth reversible ratchet
- 1 x 1/2" Drive universal joint
- 1 x Combination pliers
- 1 x Heavy duty diagonal cutting nippers
- 1 x Groove joint pliers



Item Code	Bishops Code
7087MR	61074305

15 PIECE 1/4" BIT & MINI SOCKET SET



- 5° gear action degree (72 teeth)
- Two teeth pawl action
- Includes:**
- 1 x Ratchet – 111mm
- 4 x Hex head bits – 3, 4, 5 & 6mm
- 2 x Phillips head bits – 1 & 2mm
- 3 x Torx – 10, 15 & 20mm
- 4 x Standard sockets 5, 5.5, 6, 7 & 8mm



Item Code	Bishops Code
2515MR	61036315

NAVIGATING SOCKET & RATCHET SETS

Follow this simple guide to find the socket set to suit you best.

All of these socket wrench sets include metric and imperial sockets, unless otherwise specified in the product title.

We've ordered all sets by drive size first, then by number of pieces included in the set.

Remember, this catalogue contains the little things, but not everything. If you can't find what you're looking for or if you need a special combination, just give Bishop Bros a call and we can source it for you.



18 PIECE 1/4" DRIVE 6 POINT SOCKET WRENCH SET – METRIC



- Metal case size: 198(l) x 105(w) x 32(h)mm
- Weight: 0.92kg
- Includes:**
- 2 x 1/4" Drive extension bars – 2" & 4"
- 2 x 1/4" Drive metric double square sockets – 8 & 10mm
- 10 x 1/4" Drive 6 point metric standard sockets – 4, 4.5, 5, 6, 7, 8, 9, 10, 11 & 12mm
- 1 x 1/4" Drive flexible handle
- 1 x 1/4" Drive sliding T-handle
- 1 x 1/4" Drive 24 teeth reversible ratchet
- 1 x 1/4" Drive universal joint



Item Code	Bishops Code
2519MR	61036320

18 PIECE 1/4" DRIVE 6 POINT SOCKET WRENCH SET – IMPERIAL



- Metal case size: 198(l) x 105(w) x 32(h)mm
- Weight: 0.92kg
- Includes:**
- 2 x 1/4" Drive extension bars – 2" & 4"
- 2 x 1/4" Drive imperial double square sockets – 5/16" & 3/8"
- 10 x 1/4" Drive 6 point imperial standard sockets – 5/32", 3/16", 7/32", 1/4", 9/32", 5/16", 11/32", 3/8", 7/16" & 1/2"
- 1 x 1/4" Drive flexible handle
- 1 x 1/4" Drive sliding T-handle
- 1 x 1/4" Drive 24 teeth reversible ratchet
- 1 x 1/4" Drive universal joint



Item Code	Bishops Code
2519SR	61036120



1/4" & 3/8" SOCKET & RATCHET SETS

HAND & CUTTING TOOLS

26 PIECE 1/4" DRIVE 6 POINT SOCKET WRENCH SET – METRIC



- Metal case size: 244(l) x 118(w) x 37(h)mm
- Weight: 1.3kg

Includes:

- 2 x 1/4" Drive extension bars – 2" & 4"
- 10 x 1/4" Drive 6 point metric deep sockets – 4, 4.5, 5, 6, 7, 8, 9, 10, 11 & 13mm
- 11 x 1/4" Drive 6 point metric standard sockets – 4, 4.5, 5, 5.5, 6, 7, 8, 9, 10, 11 & 13mm
- 1 x 1/4" Drive 24 teeth reversible ratchet
- 1 x 1/4" Drive universal joint
- 1 x 1/4" Drive adaptor – 1/4" F x 3/8" M



Item Code	Bishops Code
2526MR	61036340

31 PIECE 1/4" DRIVE SOCKET WRENCH SET – METRIC



- Metal case size: 280(l) x 130 (w)x 41(h)mm
- Weight: 1.6kg

Includes:

- 8 x 1/4" Drive Torx bit sockets – T8, T9, T10, T15, T20, T25, T27 & T30
- 6 x 1/4" Drive hexagon bit sockets – 3, 4, 5, 6, 8 & 10mm
- 2 x 1/4" Drive extension bars – 3" & 6"
- 11 x 1/4" Drive 6 point metric standard sockets – 4, 4.5, 5, 6, 7, 8, 9, 10, 11, 12 & 13mm
- 1 x 1/4" Drive driving handle (polycarbonates) – 150mm(6")
- 1 x 1/4" Drive sliding T-handle – 115mm(4 1/2")
- 1 x 1/4" Drive 24 teeth reversible ratchet – 130mm(5 1/8")
- 1 x 1/4" Drive universal joint – 36mm(1 1/2")



Item Code	Bishops Code
2531MR	61036350

26 PIECE 1/4" DRIVE 6 POINT SOCKET WRENCH SET – IMPERIAL



- Metal case size: 244(l) x 118(w) x 37(h)mm
- Weight: 1.3kg

Includes:

- 2 x 1/4" Drive extension bars – 2" & 4"
- 10 x 1/4" Drive 6 point imperial deep sockets – 5/32", 3/16", 7/32", 1/4", 9/32", 5/16", 11/32", 3/8", 7/16" & 1/2"
- 11 x 1/4" Drive 6 point imperial standard sockets – 5/32", 3/16", 7/32", 1/4", 9/32", 5/16", 11/32", 3/8", 7/16", 15/32" & 1/2"
- 1 x 1/4" Drive 24 teeth reversible ratchet
- 1 x 1/4" Drive universal joint
- 1 x 1/4" Drive adaptor – 1/4" F x 3/8" M



Item Code	Bishops Code
2526SR	61036140

39 PIECE 1/4" DRIVE SOCKET WRENCH SET – METRIC



- Metal case size: 316(l) x 104(w) x 40(h)mm
- Weight: 1.36kg

Includes:

- 6 x 1/4" Hex size shank drivers (hexagon head) – 3, 4, 5, 6, 7 & 8mm
- 4 x 1/4" Hex size shank drivers (Phillips head) – PH0, PH1, PH2 & PH3
- 3 x 1/4" Hex size shank drivers (slotted head) – 4, 5.5 & 7mm
- 6 x 1/4" Hex size shank drivers (for Torx internal) – T10, T15, T20, T25, T30 & T40
- 2 x 1/4" Drive extension bars – 2" & 6"
- 12 x 1/4" Drive 6 point metric standard sockets – 4, 4.5, 5, 5.5, 6, 7, 8, 9, 10, 11, 12 & 13mm
- 1 x 1/4" Drive flexible handle – 130mm(5")
- 1 x 1/4" drive sliding T-handle – 115mm(4 1/2")
- 1 x 1/4" Drive bit holder
- 1 x 1/4" Drive 24 teeth reversible ratchet – 130mm(5 1/8")
- 1 x 1/4" Drive magnetic screwdriver driver
- 1 x 1/4" Drive universal joint – 36mm(1 1/2")



Item Code	Bishops Code
2540MR	61036360

30 PIECE 1/4" DRIVE 6 POINT SOCKET WRENCH SET – METRIC & IMPERIAL



- Metal case size: 244(l) x 118(w) x 37(h)mm
- Weight: 1.3kg

Includes:

- 2 x 1/4" Drive extension bars – 2" & 4"
- 2 x 1/4" Drive metric double square sockets – 8 & 10mm
- 2 x 1/4" Drive imperial double square sockets – 5/16" & 3/8"
- 10 x 1/4" Drive 6 point metric standard sockets – 4, 4.5, 5, 6, 7, 8, 9, 10, 11 & 12mm
- 10 x 1/4" Drive 6 point imperial standard sockets – 5/32", 3/16", 7/32", 1/4", 9/32", 5/16", 11/32", 3/8", 7/16" & 1/2"
- 1 x 1/4" Drive flexible handle
- 1 x 1/4" Drive sliding T-handle
- 1 x 1/4" Drive 24 teeth reversible ratchet
- 1 x 1/4" Drive universal joint



Item Code	Bishops Code
2530CR	61036560

14 PIECE 3/8" SOCKET SET

- Chrome-vanadium steel
- Multi-fit
- Gearless direct drive ratchet to allow work in narrow areas with 0° direct movement

Includes:

- 3/8" Drive x 1/4" drive adaptor
- 5 x 3/8" Drive sockets – 1/2", 9/16", 5/8", 11/16" & 3/4"
- 7 x 1/4" Drive sockets – 7/32", 3/16", 1/4", 9/32", 5/16", 3/8" & 7/16"



Item Code	Bishops Code
W003015	63521138

20 PIECE 3/8" DRIVE 12 POINT SOCKET WRENCH SET – METRIC



- Metal case size: 372(l) x 153(w) x 40(h)mm
- Weight: 1kg
- Includes:**
- 2 x 3/8" Drive extension bars – 3" & 6"
- 13 x 3/8" Drive 12 point metric standard sockets – 6, 7, 8, 9, 10, 11, 12, 13, 14, 17, 19, 21 & 22mm
- 1 x 3/8" Drive flexible handle
- 1 x 3/8" Drive sliding T-handle
- 1 x 3/8" Drive 12 point rubber spark plug socket
- 1 x 3/8" Drive 32 teeth reversible ratchet
- 1 x 3/8" Drive universal joint



Item Code	Bishops Code
3020MR02	61044340

26 PIECE 3/8" DRIVE SOCKET WRENCH SET – IMPERIAL



- Metal case size: 318(l) x 147(w) x 46(h)mm
- Weight: 2.6kg
- Includes:**
- 1 x 3/8" Drive extension bar – 3"
- 9 x 3/8" Drive 6 point imperial deep sockets – 5/16", 3/8", 7/16", 1/2", 9/16", 5/8", 11/16", 3/4" & 13/16"
- 13 x 3/8" Drive 12 point imperial standard sockets – 1/4", 5/16", 11/32", 3/8", 7/16", 15/32", 1/2", 9/16", 19/32", 5/8", 11/16", 3/4" & 13/16"
- 1 x 3/8" Drive 32 teeth reversible ratchet
- 1 x 3/8" Drive universal joint
- 1 x 3/8" Drive adaptor – 3/8" F x 1/4" M



Item Code	Bishops Code
3027SR	61044160

22 PIECE 3/8" DRIVE 12 POINT SOCKET WRENCH SET – METRIC



- Metal case size: 372(l) x 153(w) x 40(h)mm
- Weight: 2.8kg
- Includes:**
- 2 x 3/8" Drive extension bars – 3" & 6"
- 16 x 3/8" Drive 12 point metric standard sockets – 6, 7, 8, 9, 10, 11, 12, 13, 14, 15, 16, 17, 19, 20, 21 & 22mm
- 1 x 3/8" Drive flexible handle
- 1 x 3/8" Drive sliding T-handle
- 1 x 3/8" Drive 32 teeth reversible ratchet
- 1 x 3/8" Drive universal joint



Item Code	Bishops Code
3023MR	61044350

32 PIECE 3/8" DRIVE SOCKET SET – METRIC & IMPERIAL

- Chrome-vanadium steel
- Metric/Imperial
- Includes:**
- 21 x 3/8" Sockets
- 2 x 3/8" Spark plug sockets
- 1 x Extension bar
- 1 x Ratchet handle



Item Code	Bishops Code
W003001	63521130

26 PIECE 3/8" DRIVE SOCKET WRENCH SET – METRIC



- Metal case size: 318(l) x 147(w) x 46(h)mm
- Weight: 2.6kg
- Includes:**
- 1 x 3/8" Drive extension bar – 3"
- 9 x 3/8" Drive 6 point metric deep sockets – 8, 10, 11, 12, 13, 14, 16, 17 & 19mm
- 13 x 3/8" Drive 12 point metric standard sockets – 7, 8, 9, 10, 11, 12, 13, 14, 15, 16, 17, 18 & 19mm
- 1 x 3/8" Drive 32 teeth reversible ratchet
- 1 x 3/8" Drive universal joint
- 1 x 3/8" Drive adaptor – 3/8" F x 1/4" M



Item Code	Bishops Code
3027MR	61044360

36 PIECE 3/8" DRIVE SOCKET WRENCH SET – METRIC & IMPERIAL



- Metal case size: 372(l) x 153(w) x 40(h)mm
- Weight: 3.27kg
- Includes:**
- 2 x 3/8" Drive extension bars – 3" & 6"
- 16 x 3/8" Drive 12 point metric standard sockets – 6, 7, 8, 9, 10, 11, 12, 13, 14, 15, 16, 17, 19, 20, 21 & 22mm
- 14 x 3/8" Drive 12 point imperial standard sockets – 1/4", 5/16", 11/32", 3/8", 7/16", 15/32", 1/2", 9/16", 19/32", 5/8", 11/16", 3/4", 13/16" & 7/8"
- 1 x 3/8" Drive flexible handle
- 1 x 3/8" Drive sliding T-handle
- 1 x 3/8" Drive 32 teeth reversible ratchet
- 1 x 3/8" Drive universal joint



Item Code	Bishops Code
3036CR	61044560



1/2" SOCKET & RATCHET SETS

12 PIECE 1/2" DRIVE SOCKET SET – METRIC

• Chrome-vanadium steel

Includes:

- 10 x 1/2" Metric sockets – 10, 11, 12, 13, 14, 15, 17, 19, 21 & 22mm
- 1 x 1/2" Drive extension bar – 5"
- 1 x 1/2" Drive ratchet handle



Item Code
W003024

Bishops Code
63521135

14 PIECE 1/2" DRIVE 12 POINT SOCKET WRENCH SET – IMPERIAL

- Metal case size: 445(l) x 135(w) x 50(h)mm
- Weight: 3.5kg

Includes:

- 10 x 1/2" Drive 12 point imperial standard sockets – 3/8", 7/16", 15/32", 1/2", 9/16", 11/16", 3/4", 13/16", 7/8" & 15/16"
- 1 x 1/2" Drive extension bar
- 1 x 1/2" Drive sliding T-handle
- 1 x 1/2" Drive 12 point spark plug socket
- 1 x 1/2" Drive 32 teeth reversible ratchet



Item Code
4012SR

Bishops Code
61052140

15 PIECE 1/2" DRIVE 6 POINT SOCKET WRENCH SET – METRIC

- Metal case size: 392(l) x 90(w) x 50(h)mm
- Weight: 3.4kg

Includes:

- 12 x 1/2" Drive 6 point metric standard sockets – 8, 10, 11, 12, 13, 14, 17, 19, 21, 22, 24 & 27mm
- 1 x 1/2" Drive extension bar
- 1 x 1/2" Drive flexible handle
- 1 x 1/2" Drive 32 teeth reversible ratchet



Item Code
4501MR

Bishops Code
61052350

24 PIECE 1/2" DRIVE 12 POINT SOCKET WRENCH SET – METRIC

- Metal case size: 445(l) x 187(w) x 50(h)mm
- Weight: 5.6kg

Includes:

- 2 x 1/2" Drive extension bars – 5" & 10"
- 18 x 1/2" Drive 12 point metric standard sockets – 10, 11, 12, 13, 14, 15, 16, 17, 18, 19, 20, 21, 22, 23, 24, 27, 30 & 32mm
- 1 x 1/2" Drive flexible handle
- 1 x 1/2" Drive 12 point spark plug socket
- 1 x 1/2" Drive 32 teeth reversible ratchet
- 1 x 1/2" Drive universal joint



Item Code
4032MR

Bishops Code
61052380

24 PIECE 1/2" DRIVE 12 POINT SOCKET WRENCH SET – IMPERIAL

• Metal case size: 445(l) x 187(w) x 50(h)mm

• Weight: 5.6kg

Includes:

- 2 x 1/2" Drive extension bars – 5" & 10"
- 18 x 1/2" Drive 12 point imperial standard sockets – 5/16", 3/8", 7/16", 15/32", 1/2", 9/16", 19/32", 5/8", 11/16", 3/4", 25/32", 13/16", 7/8", 15/16", 1", 1 1/16", 1 1/8" & 1 1/4"
- 1 x 1/2" Drive flexible handle
- 1 x 1/2" Drive 12 point spark plug socket
- 1 x 1/2" Drive 32 teeth reversible ratchet
- 1 x 1/2" Drive universal joint



Item Code
4032SR

Bishops Code
61052180

30 PIECE 1/2" DRIVE 12 POINT SOCKET WRENCH SET – IMPERIAL & METRIC

- 12 point, standard height
- Chrome vanadium alloy steel
- Polished, chrome plated
- 4 ball retaining groove
- Total set weight: 5.3kg

Includes:

- 15 x Metric Sockets – 10, 12, 13, 14, 15, 16, 17, 18, 19, 21, 22, 23, 24, 30 & 32mm
- 10 x A/F Sockets – 7/16", 1/2", 9/16", 5/8", 11/16", 3/4", 13/16", 7/8", 15/16" & 1"
- 1 x 1/2" Drive extension bar – 125mm
- 1 x 1/2" Drive flexible handle – 375mm
- 1 x 1/2" Drive 32 teeth reversible ratchet – 250mm
- 1 x 1/2" Drive universal joint – 77.5mm/3"
- 1 x 1/2" Drive adaptor – 1/2" F x 3/8" M



Item Code
4030CR

Bishops Code
61052375

33 PIECE 1/2" DRIVE 12 POINT SOCKET WRENCH SET – METRIC

• Metal case size: 476(l) x 282(w) x 57(h)mm

• Weight: 8.2kg

Includes:

- 3 x 1/2" Drive extension bars – 3", 5" & 10"
- 24 x 1/2" Drive 12 point metric standard sockets – 8, 9, 10, 11, 12, 13, 14, 15, 16, 17, 18, 19, 20, 21, 22, 23, 24, 25, 26, 27, 28, 29, 30 & 32mm
- 1 x 1/2" Drive flexible handle
- 1 x 1/2" Drive sliding T-handle
- 2 x 1/2" Drive 6 point spark plug socket
- 1 x 1/2" Drive 32 teeth reversible ratchet
- 1 x 1/2" Drive universal joint



Item Code
4034MR

Bishops Code
61052400

43 PIECE 1/2" DRIVE 12 POINT SOCKET SET – METRIC & IMPERIAL



- Metal case size: 476(l) x 282(w) x 57(h)mm
- Weight: 8.5kg
- Includes:**
- 23 x 1/2" Drive 12 point metric standard sockets – 8, 9, 10, 11, 12, 13, 14, 15, 16, 17, 18, 19, 20, 21, 22, 23, 24, 25, 26, 27, 28, 30 & 32mm
- 14 x 1/2" Drive 12 point imperial standard sockets – 3/8", 7/16", 1/2", 9/16", 5/8", 11/16", 3/4", 13/16", 7/8", 15/16", 1", 1 1/8", 1 1/4" & 1 1/2"
- 1 x 1/2" Drive adjustable handle
- 1 x 1/2" Drive offset extension bar
- 1 x 1/2" Drive sliding T-handle
- 1 x 1/2" Drive 105° L-handle
- 1 x 1/2" Drive 32 teeth reversible ratchet
- 1 x 1/2" Drive universal joint



Item Code	Bishops Code
4044CR	61052560

16 PIECE 3/4" DRIVE SOCKET WRENCH SET – METRIC



- Metal case size: 537(l) x 177(w) x 78(h)mm
- Weight: 14kg
- Includes:**
- 2 x 3/4" Drive extension bars – 8" & 16"
- 12 x 3/4" Drive 12 point metric standard sockets – 21, 22, 23, 24, 27, 30, 32, 36, 38, 41, 46 & 50mm
- 1 x 3/4" Drive sliding T-handle
- 1 x 3/4" Drive 24 teeth reversible ratchet



Item Code	Bishops Code
6016MR	61060320

23 PIECE 3/4" DRIVE SOCKET WRENCH SET – METRIC



- Metal case size: 537(l) x 177(w) x 78(h)mm
- Weight: 17.1kg
- Includes:**
- 3 x 3/4" Drive extension bars – 4", 8" & 16"
- 17 x 3/4" Drive 12 point metric standard sockets – 21, 22, 23, 24, 26, 27, 28, 29, 30, 32, 34, 35, 36, 38, 41, 46 & 50mm
- 1 x 3/4" Drive sliding T-handle
- 1 x 3/4" Drive 24 teeth reversible ratchet
- 1 x 3/4" Drive universal joint



Item Code	Bishops Code
6023MR	61060340

23 PIECE 3/4" DRIVE SOCKET WRENCH SET – IMPERIAL



- Metal case size: 537(l) x 177(w) x 78(h)mm
- Weight: 17.1kg
- Includes:**
- 3 x 3/4" Drive extension bars – 4", 8" & 16"
- 17 x 3/4" Drive 12 point imperial standard sockets – 7/8", 15/16", 1", 1 1/16", 1 1/8", 1 1/4", 1 1/2", 1 3/4", 1 7/8", 1 15/16", 1 3/4", 1 7/8", 1 1/2", 1 1/4", 1 1/8", 1 1/16", 1 1/8", 1 1/4", 1 1/2", 1 3/4", 1 7/8", 1 15/16", 1 3/4", 1 7/8", 1 1/2" & 2"
- 1 x 3/4" Drive sliding T-handle
- 1 x 3/4" Drive 24 teeth reversible ratchet
- 1 x 3/4" Drive universal joint



Item Code	Bishops Code
6023SR	61060140

24 PIECE 3/4" DRIVE SOCKET WRENCH SET – METRIC & IMPERIAL



- Metal case size: 537(l) x 177(w) x 78(h)mm
- Weight: 15.5kg
- Includes:**
- 2 x 3/4" Drive extension bars
- 10 x 3/4" Drive 12 point metric standard sockets – 22, 24, 27, 30, 32, 36, 38, 41, 46 & 50mm
- 10 x 3/4" Drive 12 point imperial standard sockets – 1", 1 1/8", 1 1/4", 1 1/2", 1 3/4", 1 7/8", 1 15/16", 1 1/2", 1 3/4", 1 7/8" & 2"
- 1 x 3/4" Drive sliding T-handle
- 1 x 3/4" Drive 24 teeth reversible ratchet



Item Code	Bishops Code
6224CR	61060520

14 PIECE 1" DRIVE SOCKET WRENCH SET – METRIC



- Metal case size: 660(l) x 205(w) x 108(h)mm
- Weight: 34.1kg
- Includes:**
- 2 x 1" Drive extension bars – 8" & 16"
- 10 x 1" Drive 12 point metric standard sockets – 36, 41, 46, 50, 55, 60, 65, 70, 75 & 80mm
- 1 x 1" Drive sliding T-handle
- 1 x 1" Drive 24 teeth reversible ratchet



Item Code	Bishops Code
8015MR	61068140

14 PIECE 1" DRIVE SOCKET WRENCH SET – IMPERIAL



- Metal case size: 660(l) x 205(w) x 108(h)mm
- Weight: 34.1kg
- Includes:**
- 2 x 1" Drive extension bars – 8" & 16"
- 10 x 1" Drive 12 part imperial standard sockets – 1 1/16", 1 1/8", 1 1/4", 1 1/2", 1 3/4", 1 7/8", 1 15/16", 2", 2 1/4", 2 3/8", 2 1/2", 2 5/8" & 3"
- 1 x 1" Drive sliding T-handle
- 1 x 1" Drive 24 teeth reversible ratchet



Item Code	Bishops Code
8015SR	61068120



COMBINATION SOCKET & RATCHET SETS

HAND & CUTTING TOOLS

39 PIECE 1/4" & 3/8" DRIVE COMBINATION SOCKET SET METRIC & IMPERIAL



- Metal case size: 318(l) x 147(w) x 46(h)mm
- Weight: 2.6kg

Includes:

- 9 x 1/4" Drive 6 point metric standard sockets – 4.5, 5, 6, 7, 8, 9, 10, 11 & 12mm
- 9 x 1/4" Drive 6 point imperial standard sockets – 3/16", 7/32", 1/4", 9/32", 5/16", 11/32", 3/8", 7/16" & 1/2"
- 1 x 3/8" Drive extension bars – 3"
- 9 x 3/8" Drive 12 point metric standard sockets – 9, 10, 11, 12, 13, 14, 16, 17 & 19mm
- 7 x 3/8" Drive 12 point imperial standard sockets – 3/8", 7/16", 1/2", 9/16", 5/8", 11/16" & 3/4"
- 1 x 1/4" Drive driving handle
- 1 x 3/8" Drive 12 point rubber spark plug socket
- 1 x 3/8" Drive 32 teeth reversible ratchet
- 1 x 3/8" Drive adaptor – 3/8" F x 1/4" M



Item Code	Bishops Code
5039CR	61028520

91 PIECE 1/4" & 3/8" DRIVE COMBINATION SOCKET SET



- Metal case size: 445 x 187 x 50mm
- Weight: 4.4kg

Includes:

- 3 x Male hand keys – 1.5, 2 & 2.5mm
- 4 x 1/4" Drive Phillips bit sockets – PH1, PH2, PH3 & PH4
- 6 x Ball hex keys (extra long arm) – 3, 4, 5, 6, 8 & 10mm
- 6 x Hex sockets – 1/8", 3/16", 7/32", 1/4", 5/16" & 3/8"
- 2 x 1/4" Drive extension bars – 55 & 100mm
- 12 x 1/4" Drive 6 point metric deep sockets – 4, 4.5, 5, 5.5, 6, 7, 8, 9, 10, 11, 12 & 13mm
- 10 x 1/4" drive 6 point SAE deep sockets – 5/32", 3/16", 7/32", 1/4", 9/32", 5/16", 11/32", 3/8", 7/16" and 1/2"
- 12 x 1/4" Drive 6 point metric standard sockets – 4, 4.5, 5, 5.5, 6, 7, 8, 9, 10, 11, 12 & 13mm
- 10 x 1/4" Drive 6 point SAE standard sockets – 5/32", 3/16", 7/32", 1/4", 9/32", 5/16", 11/32", 3/8", 7/16" & 1/2"
- 1 x Cross bar – 4 1/2"
- 2 x 3/8" Drive extension bars – 75 & 150mm
- 15 x 3/8" Drive 12 point metric standard sockets – 8, 9, 10, 11, 12, 13, 14, 15, 16, 17, 18, 19, 20, 21 & 22mm
- 1 x 3/8" Drive spin disc
- 1 x 1/4" Drive driving handle (polycarbonates)
- 1 x 1/4" Drive flexible handle
- 1 x 1/4" Drive sliding T-handle
- 1 x 3/8" Drive 6 point rubber spark plug socket
- 1 x 3/8" Drive 32 teeth reversible ratchet
- 1 x 3/8" Drive universal joint
- 1 x 3/8" Drive adaptor – 3/8" F x 1/4" M



Item Code	Bishops Code
5092CR	61028540

62 PIECE 1/4", 3/8" & 1/2" DRIVE COMBINATION SOCKET WRENCH SET – METRIC



- Metal case size: 476(l) x 282(w) x 57(h)mm
- Weight: 7.4kg

Includes:

- 1 x 1/4" Drive extension bar – 4"
- 10 x 1/4" Drive 6 point metric standard sockets – 4, 4.5, 5, 6, 7, 8, 9, 10, 11 & 12mm
- 5 x 3/8" Drive Torx bit sockets – T20, T25, T27, T30 & T40
- 5 x 3/8" Drive hexagon bit sockets – 4, 5, 6, 8 & 10mm
- 1 x 3/8" Drive extension bar – 6"
- 4 x 3/8" Drive 6 point metric deep sockets – 10, 13, 17 & 19mm
- 10 x 3/8" Drive 12 point metric standard sockets – 8, 9, 10, 11, 12, 13, 14, 15, 17 & 19mm
- 1 x 1/2" Drive extension bar – 6"
- 16 x 1/2" Drive 12 point metric standard sockets – 12, 13, 14, 15, 16, 17, 18, 19, 20, 21, 22, 23, 24, 27, 30 & 32mm



Item Code	Bishops Code
9063MR01	61028560

135 PIECE 1/4", 3/8" & 1/2" DRIVE COMBINATION SOCKET SET



- Metal case size: 450(l) x 370(w) x 56(h)mm
- Weight: 12.3kg

Includes:

- 3 x Hex key – 1.5, 2 & 2.5mm
- 4 x Phillips bit sockets – PH1, PH2, PH3 & PH4
- 6 x Hex bit socket – 3, 4, 5, 6, 8 & 10mm
- 6 x Hex bit socket – 1/8", 3/16", 7/32", 1/4", 5/16" & 3/8"
- 2 x 1/4" Drive extension bars – 2" & 4"
- 12 x 1/4" Drive 6 point metric deep sockets – 4, 4.5, 5, 5.5, 6, 7, 8, 9, 10, 11, 12 & 13mm
- 10 x 1/4" Drive 6 point SAE deep sockets – 5/32", 3/16", 7/32", 1/4", 9/32", 5/16", 11/32", 3/8", 7/16" & 1/2"
- 12 x 1/4" Drive 6 point metric standard sockets – 4, 4.5, 5, 5.5, 6, 7, 8, 9, 10, 11, 12 & 13mm
- 10 x 1/4" Drive 6 point SAE standard sockets – 5/32", 3/16", 7/32", 1/4", 9/32", 5/16", 11/32", 3/8", 7/16" & 1/2"
- 2 x 3/8" Drive extension bars – 3" & 6"
- 15 x 3/8" Drive 12 point metric standard sockets – 8, 9, 10, 11, 12, 13, 14, 15, 16, 17, 18, 19, 20, 21 & 22mm
- 2 x 1/2" Drive extension bars – 5" & 10"
- 23 x 1/2" Drive 12 point metric standard sockets – 8, 9, 10, 11, 12, 13, 14, 15, 16, 17, 18, 19, 20, 21, 22, 23, 24, 25, 26, 27, 28, 30 & 32mm
- 14 x 1/2" Drive 12 point SAE standard socket – 3/8", 7/16", 1/2", 9/16", 5/8", 11/16", 3/4", 13/16", 7/8", 15/16", 1", 1 1/8", 1 1/4" & 1 1/2"
- 1 x Cross bar – 4 1/2"
- 2 x Drive spin discs – 1/2" & 3/8"
- 1 x 1/4" Drive driving handle (polycarbonate)
- 1 x 1/4" Drive flexible handle
- 1 x 1/4" Drive sliding T-handle
- 1 x 3/8" Drive 32 teeth reversible ratchet
- 1 x 3/8" Drive universal joint
- 1 x 3/8" Drive adaptor – 3/8" F x 1/4" M
- 1 x 1/2" Drive sliding T-handle
- 2 x 1/2" Drive 12 point spark plug sockets
- 1 x 1/2" Drive 32 teeth reversible ratchet
- 1 x 1/2" Drive universal joint



Item Code	Bishops Code
9033CR	61028580

8 PIECE 1/2" DRIVE 12 POINT DEEP SOCKET SET – METRIC



- Metal case size: 246(l) x 103(w) x 38(h)mm
- Weight: 1.93kg
- Includes:**
- Sizes: 12, 13, 14, 17, 19, 21, 22 & 23mm



Item Code	Bishops Code
4208MR	61052710

8 PIECE 1/2" DRIVE 12 POINT DEEP SOCKET SET – IMPERIAL



- Metal case size: 246(l) x 103(w) x 38(h)mm
- Weight: 1.93kg
- Includes:**
- Sizes: 1/2", 9/16", 5/8", 11/16", 3/4", 13/16", 7/8" & 15/16"



Item Code	Bishops Code
4208SR	61052705

15 PIECE 1/2" DRIVE 12 POINT DEEP SOCKET SET – METRIC



- Metal case size: 445(l) x 135(w) x 50(h)mm
- Weight: 3.80kg
- Includes:**
- Sizes: 10, 11, 12, 13, 14, 15, 16, 17, 19, 21, 22, 24, 27, 30 & 32mm



Item Code	Bishops Code
4215MR	61052340

16 PIECE 1/2" DRIVE 12 POINT DEEP SOCKET SET – METRIC



- Metal case size: 445(l) x 135(w) x 50(h)mm
- Weight: 3.68kg
- Includes:**
- Sizes: 10, 11, 12, 13, 14, 15, 16, 17, 18, 19, 21, 22, 24, 27, 30 & 32mm



Item Code	Bishops Code
4216MR	61052345

13 PIECE 3/8" DRIVE 12 POINT SOCKET RAIL SET – METRIC



- Weight: 0.52kg
- Includes:**
- 13 x 3/8" Drive 12 point metric standard sockets – 7, 8, 9, 10, 11, 12, 13, 14, 15, 16, 17, 18 & 19mm
- 1 x 3/8" Drive socket rail & clip – 290mm



Item Code	Bishops Code
3013MR	61044320

13 PIECE 3/8" DRIVE 12 POINT SOCKET RAIL SET – IMPERIAL



- Weight: 0.52kg
- Includes:**
- 13 x 3/8" Drive 12 point imperial standard sockets – 1/4", 5/16", 11/32", 3/8", 7/16", 15/32", 1/2", 9/16", 19/32", 5/8", 11/16", 3/4" & 13/16"
- 1 x 3/8" Drive socket rail & clip – 290mm



Item Code	Bishops Code
3013SR	61044120

8 PIECE 1/2" DRIVE 12 POINT SOCKET RAIL SET – METRIC



- Weight: 0.64kg
- Includes:**
- 8 x 1/2" Drive 12 point metric standard sockets – 10, 12, 13, 14, 17, 19, 21 & 22mm
- 1 x 1/2" Drive socket rail & clip – 230mm



Item Code	Bishops Code
4010MR	61052320

8 PIECE 1/2" DRIVE 12 POINT SOCKET RAIL SET – IMPERIAL



- Weight: 0.64kg
- Includes:**
- 8 x 1/2" Drive 12 point imperial standard sockets – 3/8", 7/16", 1/2", 9/16", 11/16", 3/4", 13/16" & 7/8"
- 1 x 1/2" Drive socket rail & clip – 230mm



Item Code	Bishops Code
4010SR	61052120



1/4" & 3/8" CHROME SOCKETS

HAND & CUTTING TOOLS

1/4" DRIVE 6 POINT STANDARD SOCKETS - METRIC

- Chrome vanadium alloy steel, polished, chrome plated
- 4 ball retaining grooves
- Thin walled design on square driving side
- IN 3124, ISO 2725-1

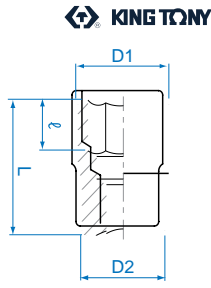

Item Code	Size	D1	D2	ℓ	Length	Weight	Bishops Code
233504M	4mm	6.8mm	11.8mm	4mm	24mm	10g	61031040
233545M	4.5mm	4.5mm	7.4mm	5mm	24mm	10g	61031045
233505M	5mm	8mm	11.8mm	6mm	24mm	11g	61031050
233555M	5.5mm	8.7mm	11.8mm	6mm	24mm	11g	61031055
233506M	6mm	9.2mm	11.8mm	7mm	24mm	11g	61031060
233507M	7mm	10.3mm	11.8mm	7mm	24mm	11g	61031070
233508M	8mm	11.4mm	11.8mm	8mm	24mm	11g	61031080
233509M	9mm	12.8mm	12mm	8mm	24mm	15g	61031090
233510M	10mm	14.3mm	13mm	9mm	24mm	14g	61031100
233511M	11mm	15.8mm	14.2mm	9mm	24mm	20g	61031110
233512M	12mm	16.8mm	15.5mm	9mm	24mm	22g	61031120
233513M	13mm	17.8mm	16.5mm	9mm	24mm	24g	61031130

1/4" DRIVE 6 POINT STANDARD SOCKETS - IMPERIAL

- Chrome vanadium alloy steel, polished, chrome plated
- 4 ball retaining grooves
- Thin walled design on square driving side
- ANSI/ASME B107.1

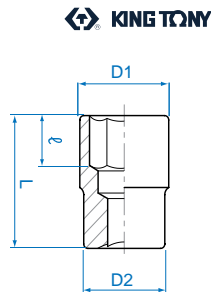

Item Code	Size	D1	D2	ℓ	Length	Weight	Bishops Code
233505S	5/32"	6.8mm	11.8mm	4mm	24mm	10g	61030016
233506S	3/16"	7.9mm	11.8mm	6mm	24mm	10g	61030018
233507S	7/32"	8.7mm	11.8mm	6mm	24mm	10g	61030024
233508S	1/4"	9.5mm	11.8mm	7mm	24mm	11g	61030025
233509S	9/32"	10.3mm	11.8mm	7mm	24mm	11g	61030028
233510S	5/16"	11.4mm	11.8mm	8mm	24mm	11g	61030031
233511S	11/32"	13.7mm	12.2mm	8mm	24mm	13g	61030034
233512S	3/8"	14.2mm	13mm	8mm	24mm	14g	61030037
233514S	7/16"	15.8mm	14.2mm	9mm	24mm	19g	61030043
233515S	15/32"	16.8mm	15.5mm	9mm	24mm	22g	61030046
233516S	1/2"	17.6mm	16.5mm	9mm	24mm	24g	61030050

1/4" DRIVE 6 POINT DEEP SOCKETS - METRIC

- Chrome vanadium alloy steel, polished, chrome plated
- 4 ball retaining grooves
- DIN 3124, ISO 2725-1

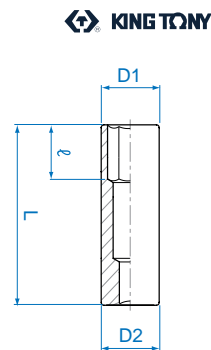

Item Code	Size	D1	D2	ℓ	Length	Weight	Bishops Code
223504M	4mm	6.8mm	11.8mm	6mm	50mm	20g	61031504
223505M	5mm	8mm	11.8mm	7mm	50mm	21g	61031505
223506M	6mm	9.2mm	11.8mm	9mm	50mm	23g	61031506
223508M	8mm	11.8mm	11.8mm	15mm	50mm	24g	61031508
223509M	9mm	13mm	13mm	15mm	50mm	29g	61031509
223510M	10mm	14.5mm	14.5mm	15mm	50mm	38g	61031510
223511M	11mm	15.8mm	15.8mm	21mm	50mm	44g	61031511
223512M	12mm	16.8mm	16.8mm	21mm	50mm	53g	61031520

1/4" DRIVE 6 POINT DEEP SOCKETS - IMPERIAL

- Chrome vanadium alloy steel, polished, chrome plated
- 4 ball retaining grooves
- DIN 3124, ISO 2725-1

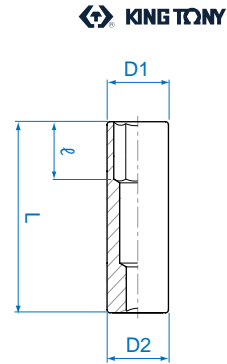

Item Code	Size	D1	D2	ℓ	Length	Weight	Bishops Code
223507S	7/32"	8.7mm	11.8mm	9mm	50mm	25g	61030524
223508S	1/4"	9.5mm	11.8mm	9mm	50mm	25g	61030525

3/8" DRIVE 12 POINT STANDARD SOCKETS - METRIC

- Chrome vanadium alloy steel, polished, chrome plated
- 4 ball retaining grooves
- Thin walled design on square driving side
- DIN 3124, ISO 2725-1

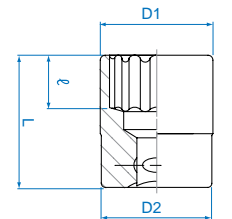

Item Code	Size	D1	D2	ℓ	Length	Weight	Bishops Code
333006M	6mm	9.9mm	17.8mm	7mm	27mm	24g	61039060
333007M	7mm	10.8mm	17.8mm	7mm	27mm	24g	61039070
333008M	8mm	12mm	17.8mm	8mm	27mm	25g	61039080
333009M	9mm	9.9mm	17.8mm	8mm	27mm	25g	61039090
333010M	10mm	14.5mm	17.8mm	9mm	27mm	26g	61039100
333011M	11mm	15.8mm	17.8mm	9mm	27mm	27g	61039110
333012M	12mm	16.8mm	17.8mm	9mm	27mm	27g	61039120
333013M	13mm	17.8mm	16.8mm	9mm	27mm	30g	61039130
333014M	14mm	19.7mm	18mm	9mm	29mm	33g	61039140
333015M	15mm	20.8mm	18mm	11mm	29mm	40g	61039150
333016M	16mm	21.8mm	20mm	11mm	29mm	39g	61039160
333017M	17mm	23.8mm	20mm	11mm	29mm	52g	61039170
333018M	18mm	24.7mm	21mm	13mm	29mm	58g	61039180
333019M	19mm	25.8mm	21mm	13mm	29mm	62g	61039190
333020M	20mm	27.1mm	25mm	13mm	32mm	73g	61039200
333021M	21mm	27.8mm	25mm	13mm	32mm	82g	61039210
333022M	22mm	29.7mm	26mm	15mm	32mm	87g	61039220

3/8" DRIVE 12 POINT STANDARD SOCKETS - IMPERIAL

- Chrome vanadium alloy steel, polished, chrome plated
- 4 ball retaining grooves
- Thin walled design on square driving side
- ANSI/ASME B107.1

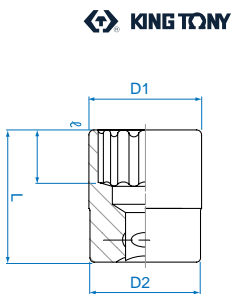

Item Code	Size	D1	D2	ℓ	Length	Weight	Bishops Code
333008S	1/4"	10mm	17.8mm	7mm	27mm	25g	61038025
333010S	5/16"	12mm	17.8mm	7mm	27mm	22g	61038032
333012S	3/8"	14mm	17.8mm	9mm	27mm	26g	61038037
333014S	7/16"	15.8mm	17.8mm	9mm	27mm	27g	61038043
333016S	1/2"	17.8mm	16.8mm	9mm	27mm	30g	61038050
333018S	9/16"	19.7mm	18mm	11mm	29mm	33g	61038056
333020S	5/8"	21.8mm	20mm	11mm	29mm	43g	61038062
333022S	11/16"	23.8mm	20mm	11mm	29mm	52g	61038068
333024S	3/4"	25.7mm	21mm	13mm	29mm	62g	61038075
333026S	13/16"	27.8mm	24mm	13mm	32mm	77g	61038081
333028S	7/8"	29.6mm	26mm	15mm	32mm	87g	61038087

1/2" DRIVE 12 POINT STANDARD SOCKETS - METRIC



- Chrome vanadium alloy steel, polished, chrome plated
- 4 ball retaining grooves
- Thin walled design on square driving side
- DIN 3124, ISO 2725-1

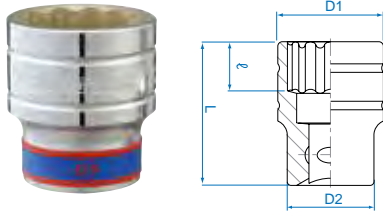

Item Code	Size	D1	D2	ℓ	Length	Weight	Bishops Code
433008M	8mm	13.2mm	23.3mm	7mm	38mm	57g	61047080
433009M	9mm	14mm	23.3mm	7mm	38mm	60g	61047090
433010M	10mm	15mm	23.3mm	8mm	38mm	58g	61047100
433011M	11mm	16.4mm	23.3mm	8mm	38mm	58g	61047110
433012M	12mm	17.8mm	23.3mm	9mm	38mm	60g	61047120
433013M	13mm	19mm	23.3mm	10mm	38mm	60g	61047130
433014M	14mm	20.4mm	23.3mm	11mm	38mm	61g	61047140
433015M	15mm	21.6mm	23.3mm	11mm	38mm	62g	61047150
433016M	16mm	22.5mm	23.3mm	11mm	38mm	63g	61047160
433017M	17mm	24mm	23.2mm	12mm	38mm	66g	61047170
433018M	18mm	25.2mm	23.2mm	13mm	38mm	66g	61047180
433019M	19mm	26.6mm	23.2mm	13mm	38mm	73g	61047190
433020M	20mm	27.9mm	23.2mm	13mm	38mm	86g	61047200
433021M	21mm	28.9mm	23.2mm	14mm	38mm	97g	61047210
433022M	22mm	30.2mm	24mm	15mm	40mm	99g	61047220
433023M	23mm	31.2mm	25mm	15mm	40mm	99g	61047230
433024M	24mm	32.1mm	26mm	17mm	42mm	113g	61047240
433025M	25mm	33.4mm	27mm	17mm	42mm	125g	61047250
433026M	26mm	35mm	28mm	17mm	42mm	130g	61047260
433027M	27mm	36.6mm	28mm	19mm	42mm	135g	61047270
433028M	28mm	37.8mm	30mm	20mm	42mm	151g	61047280
433029M	29mm	39mm	30mm	21mm	44mm	169g	61047290
433030M	30mm	40mm	29.5mm	21mm	44mm	169g	61047300
433032M	32mm	42.5mm	30mm	23mm	44mm	173g	61047320
433033M	33mm	43mm	30mm	24mm	46mm	217g	61047330
433036M	36mm	47mm	33mm	24mm	46mm	238g	61047360

1/2" DRIVE 12 POINT STANDARD SOCKETS - IMPERIAL



- Chrome vanadium alloy steel, polished, chrome plated
- 4 ball retaining grooves
- Thin walled design on square driving side
- ANSI/ASME B107.1

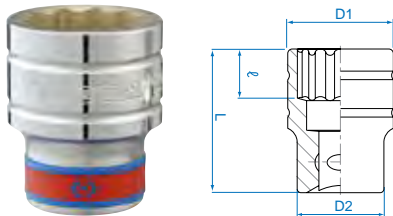

Item Code	Size	D1	D2	ℓ	Length	Weight	Bishops Code
433012S	3/8"	15mm	21.8mm	7mm	38mm	59g	61046037
433014S	7/16"	16.4mm	23.3mm	8mm	38mm	60g	61046043
433015S	15/32"	18mm	23.3mm	8mm	38mm	62g	61046046
433016S	1/2"	19mm	23.3mm	10mm	38mm	62g	61046050
433018S	9/16"	20.4mm	23.3mm	11mm	38mm	62g	61046056
433020S	5/8"	22.5mm	23.3mm	11mm	38mm	62g	61046062
433022S	11/16"	24mm	23.2mm	12mm	38mm	70g	61046068
433024S	3/4"	26.8mm	23.2mm	13mm	38mm	83g	61046075
433026S	13/16"	28.6mm	23.2mm	13mm	38mm	95g	61046081
433028S	7/8"	30.2mm	24mm	15mm	40mm	102g	61046087
433030S	15/16"	32.6mm	26mm	17mm	42mm	112g	61046093
433032S	1"	34.8mm	26.8mm	17mm	42mm	130g	61046100
433034S	1 1/16"	36.6mm	28mm	19mm	42mm	135g	61046106
433036S	1 1/8"	39mm	30mm	21mm	44mm	160g	61046112
433038S	1 3/16"	40mm	29.5mm	21mm	44mm	169g	61046118
433040S	1 1/4"	42.5mm	30mm	23mm	44mm	173g	61046125

1/2" DRIVE 12 POINT DEEP SOCKETS - METRIC



- Chrome vanadium alloy steel
- Polished and chrome plated
- 4 ball retaining grooves
- DIN 3124, ISO 2725-1

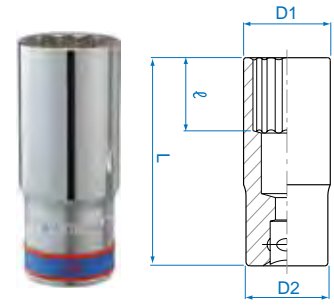

Item Code	Size	D1	D2	ℓ	Length	Weight	Bishops Code
423010M	10mm	15.2mm	23.7mm	24mm	77mm	116g	61047510
423012M	12mm	17.7mm	23.7mm	24mm	77mm	123g	61047512
423013M	13mm	18.7mm	23.7mm	24mm	77mm	125g	61047513
423014M	14mm	20.2mm	23.7mm	35mm	77mm	138g	61047514
423017M	17mm	23.7mm	23.2mm	35mm	77mm	151g	61047517
423018M	18mm	25.5mm	23.2mm	35mm	77mm	182g	61047518
423019M	19mm	26.7mm	23.2mm	35mm	77mm	176g	61047519
423021M	21mm	28.7mm	25mm	35mm	77mm	220g	61047521
423022M	22mm	29.8mm	26mm	35mm	77mm	205g	61047522
423023M	23mm	31.8mm	27.5mm	35mm	77mm	207g	61047523

1/2" DRIVE 12 POINT DEEP SOCKETS - IMPERIAL



- Chrome vanadium alloy steel, polished, chrome plated
- 4 ball retaining grooves
- Thin walled design on square driving side
- ANSI/ASME B107.1

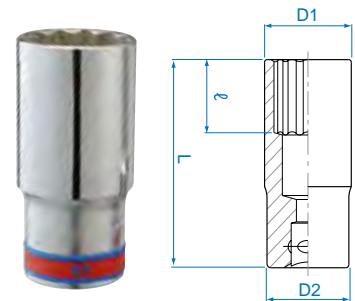

Item Code	Size	D1	D2	ℓ	Length	Weight	Bishops Code
423012S	3/8"	14.7mm	22mm	10mm	77mm	116g	61046537
423016S	1/2"	18.7mm	23.7mm	14mm	77mm	125g	61046550
423020S	5/8"	22.6mm	23.7mm	17mm	77mm	147g	61046562
423024S	3/4"	26.7mm	23.2mm	35mm	77mm	176g	61046575
423028S	7/8"	29.8mm	26mm	37mm	77mm	203g	61046587

GET MORE AT BISHOPS



TORQUE WRENCHES

Page 191



3/4" CHROME SOCKETS

3/4" DRIVE 12 POINT STANDARD SOCKETS - METRIC

- Chrome vanadium alloy steel, polished, chrome plated
- 4 ball retaining grooves
- Thin walled design on square driving side
- DIN 3124, ISO 2725-1

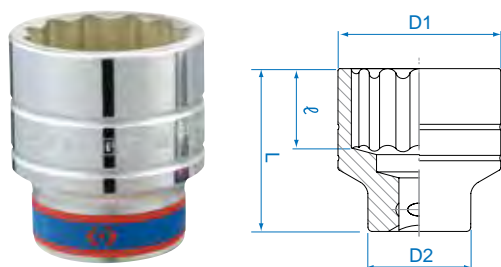

Item Code	Size	D1	D2	ℓ	Length	Weight	Bishops Code
633019M	19mm	30mm	32.7mm	14mm	51mm	207g	61055019
633021M	21mm	32mm	32.7mm	16mm	51mm	210g	61055021
633022M	22mm	33mm	35.7mm	16mm	51mm	209g	61055022
633023M	23mm	34mm	35.7mm	16mm	51mm	216g	61055023
633024M	24mm	35mm	35.7mm	17mm	51mm	219g	61055024
633026M	26mm	35.7mm	35mm	17mm	52mm	243g	61055026
633027M	27mm	38mm	36mm	19mm	52mm	238g	61055027
633028M	28mm	39mm	36mm	19mm	52mm	233g	61055028
633029M	29mm	40mm	38mm	19mm	52mm	261g	61055029
633030M	30mm	42mm	38mm	21mm	54mm	295g	61055030
633032M	32mm	44mm	38mm	23mm	56mm	317g	61055032
633033M	33mm	46mm	39mm	23mm	56mm	351g	61055033
633034M	34mm	47mm	42mm	24mm	57mm	400g	61055034
633035M	35mm	48mm	42mm	25mm	58mm	406g	61055035
633036M	36mm	50mm	42mm	25mm	58mm	434g	61055036
633038M	38mm	52mm	45mm	27mm	60mm	497g	61055038
633041M	41mm	56mm	45mm	29mm	64mm	581g	61055041
633042M	42mm	57mm	45mm	29mm	64mm	591g	61055042
633046M	46mm	62mm	48mm	33mm	68mm	729g	61055046
633048M	48mm	64mm	45mm	34mm	70mm	775g	61055048
633050M	50mm	68mm	48mm	34mm	72mm	889g	61055050

3/4" DRIVE 12 POINT DEEP SOCKETS - METRIC

- Chrome vanadium alloy steel
- Polished and chrome plated
- 4 ball retaining grooves
- DIN 3124, ISO 2725-1

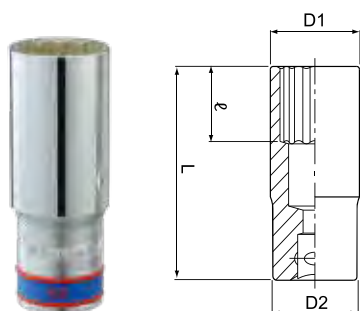

Item Code	Size	D1	D2	ℓ	Length	Weight	Bishops Code
623032M	32mm	44mm	38mm	34mm	90mm	568g	61047525
623033M	33mm	46mm	39mm	34mm	90mm	542g	61047526
623036M	36mm	50mm	42mm	37mm	90mm	608g	61047527
623039M	39mm	53mm	45mm	41mm	90mm	666g	61047528
623041M	41mm	56mm	45mm	41mm	90mm	701g	61047529
623046M	46mm	62mm	48mm	46mm	95mm	889g	61047530
623050M	50mm	68mm	48mm	50mm	95mm	1.022kg	61047531

3/4" DRIVE 12 POINT STANDARD SOCKETS - IMPERIAL

- Chrome vanadium alloy steel, polished, chrome plated
- 4 ball retaining grooves
- Thin walled design on square driving side
- ANSI/ASME B107.1

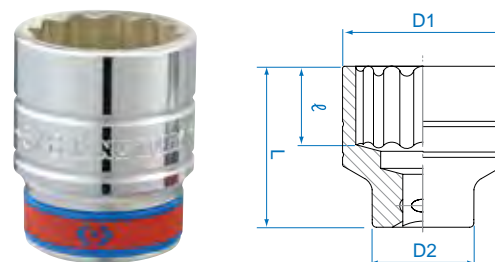

Item Code	Size	D1	D2	ℓ	Length	Weight	Bishops Code
633024S	3/4"	30mm	35.7mm	14mm	50.8mm	225g	61054075
633026S	13/16"	32mm	35.7mm	14mm	50.8mm	228g	61054081
633028S	7/8"	33mm	35.7mm	16mm	51mm	230g	61054087
633030S	15/16"	35mm	35.7mm	17mm	51mm	240g	61054093
633032S	1"	35mm	35.7mm	17mm	52mm	242g	61054100
633034S	1 1/16"	38mm	36mm	19mm	52mm	238g	61054106
633036S	1 1/8"	40mm	38mm	19mm	52mm	261g	61054112
633038S	1 3/16"	42mm	38mm	21mm	54mm	295g	61054118
633040S	1 1/4"	44mm	38mm	23mm	56mm	317g	61054125
633042S	1 5/16"	46mm	39mm	23mm	56mm	351g	61054131
633044S	1 3/8"	48mm	42mm	25mm	58mm	406g	61054137
633046S	1 7/16"	50mm	42mm	25mm	58mm	434g	61054143
633048S	1 1/2"	52mm	35.7mm	27mm	60mm	497kg	61054150
633050S	1 5/8"	54mm	45mm	28mm	62mm	537kg	61054155
633052S	1 5/8"	56mm	45mm	29mm	64mm	581kg	61054162
633054S	1 11/16"	58mm	45mm	29mm	65mm	591kg	61054168
633056S	1 3/4"	60mm	48mm	31mm	66mm	657kg	61054175
633058S	1 13/16"	62mm	48mm	34mm	68mm	724kg	61054181
633060S	1 7/8"	64mm	48mm	34mm	70mm	775kg	61054187
633064S	2"	68mm	48mm	34mm	72mm	889kg	61054200
633066S	2 1/16"	70mm	50mm	35mm	74mm	950kg	61054206
633068S	2 1/8"	72mm	50mm	35mm	75mm	1.02kg	61054212
633070S	2 3/16"	74mm	50mm	37mm	76mm	1.12kg	61054218
633072S	2 1/4"	76mm	50mm	37mm	76mm	1.12kg	61054225
633074S	2 5/16"	78mm	50mm	37mm	78mm	1.16kg	61054231
633076S	2 3/8"	80mm	50mm	40mm	78mm	1.24kg	61054237
633078S	2 1/2"	82mm	55mm	40mm	81mm	1.366kg	61054243
633080S	2 5/8"	84mm	55mm	40mm	81mm	1.460kg	61054250

GET MORE AT BISHOPS



LED WORK LIGHTS

Page 375

1" DRIVE 12 POINT STANDARD SOCKETS – METRIC

- Chrome vanadium alloy steel, polished, chrome plated
- 4 ball retaining grooves
- Thin walled design on square driving side
- DIN 3124, ISO 2725-1

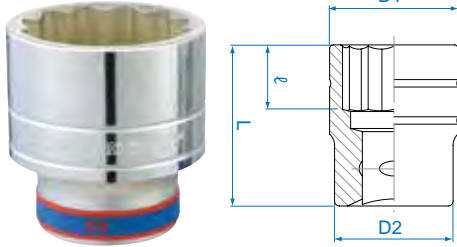

Item Code	Size	D1	D2	ℓ	Length	Weight	Bishops Code
833036M	36mm	52mm	48mm	26mm	65mm	449g	61063036
833038M	38mm	54mm	48mm	26mm	65mm	478g	61063038
833041M	41mm	58mm	50mm	29mm	70mm	557g	61063041
833046M	46mm	65mm	54mm	32mm	75mm	849g	61063046
833050M	50mm	70mm	54mm	34mm	75mm	996g	61063050
833055M	55mm	76mm	57mm	42mm	83mm	1.20kg	61063055
833060M	60mm	82mm	58mm	46mm	87mm	1.47kg	61063060
833065M	65mm	88mm	65mm	49mm	90mm	1.67kg	61063065
833070M	70mm	94mm	70mm	50mm	93mm	2.10kg	61063070
833075M	75mm	100mm	70mm	50mm	95mm	2.31kg	61063075

1" DRIVE 12 POINT STANDARD SOCKETS – IMPERIAL

- Chrome vanadium alloy steel, polished, chrome plated
- 4 ball retaining grooves
- Thin walled design on square driving side
- ANSI/ASME B107.1

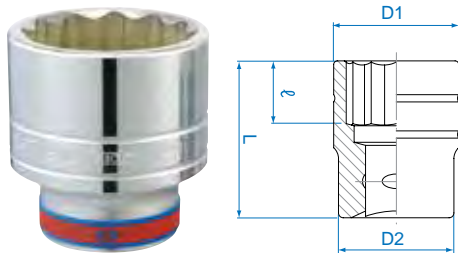

Item Code	Size	D1	D2	ℓ	Length	Weight	Bishops Code
833048S	1½"	54mm	48mm	26mm	65mm	489g	61062150
833054S	1⅞"	60mm	54mm	28mm	70mm	680g	61062168
833060S	1¾"	67mm	54mm	34mm	75mm	976g	61062187
833064S	2"	71mm	54mm	34mm	75mm	988g	61062200
833072S	2¼"	78mm	57mm	42mm	83mm	1.212kg	61062225
833076S	2¾"	82mm	58mm	46mm	87mm	1.437kg	61062237
833084S	2¾"	90mm	65mm	49mm	90mm	1.693kg	61062262
833094S	2⅝"	100mm	70mm	52mm	95mm	2.242kg	61062293
8330A0S	3¾"	107mm	80mm	52mm	100mm	2.578kg	61062312

7 PIECE ¼" DRIVE INHEX BIT SOCKET SET – METRIC

- Weight: 0.15kg
- Includes:**
- 7 x ¼" Drive hexagon bit sockets – 3, 4, 5, 6, 7, 8 & 10mm
- 1 x ¼" Drive socket rail & clip – 130mm



Item Code	Bishops Code
2127PR	61052325



8 PIECE ½" DRIVE HEX SOCKET SET – METRIC

- Chrome plated sockets with phosphate in hex drives
- Includes:**
- 8 x ½" Drive hex bit sockets – 6, 7, 8, 10, 12, 14, 17 & 19mm
- 1 x Socket rail & clip – 240mm



Item Code	Bishops Code
4108PR10	61052565

9 PIECE ½" DRIVE INHEX BIT SOCKET SET – METRIC

- Weight: 1kg
- Includes:**
- 9 x ½" Drive hexagon bit sockets – 4, 5, 6, 7, 8, 10, 12, 14 & 17mm
- 1 x ½" Drive socket rail and clip – 240mm



Item Code	Bishops Code
4120PR10	61052323

9 PIECE ½" DRIVE INHEX BIT SOCKET SET – METRIC

- Metal case size: 198(l) x 105(w) x 32(h)mm
- Weight: 1.03kg
- Includes:**
- 9 x Hexagon bit sockets – 3, 4, 5, 6, 7, 8, 10, 12 & 14mm



Item Code	Bishops Code
4110PR	61052720

9 PIECE ½" DRIVE INHEX BIT SOCKET SET – METRIC

- Metal case size: 198(l) x 105(w) x 32(h)mm
- Weight: 1.38kg
- Includes:**
- 9 x Hexagon bit sockets – 4, 5, 6, 7, 8, 10, 12, 14 & 17mm



Item Code	Bishops Code
4120PR	61052725



SPECIALTY CHROME SOCKET SETS & INHEX SOCKETS

HAND & CUTTING TOOLS

9 PIECE 1/2" DRIVE TORX BIT SOCKET SET – METRIC



- Weight: 0.84kg
- Includes:**
- 9 x 1/2" Drive Torx sockets – T20, T25, T27, T30, T40, T45, T50, T55 & T60mm
- 1 x 1/2" Drive socket rail & clip – 240mm



Item Code	Bishops Code
4119PR10	61052322

9 PIECE 1/2" DRIVE TORX HEAD BIT SOCKET SET



- Length: 55mm
- Metal case size: 198(l) x 105(w) x 32(h)mm
- Case weight: 1.03kg
- Includes:**
- Sizes: T20, T25, T27, T30, T40, T45, T50, T55 & T60



Item Code	Bishops Code
4109PR	61052740

6 PIECE 1/2" DRIVE STAR SOCKET RAIL SET



- Weight: 0.51kg
- Includes:**
- 6 x 1/2" Drive star sockets – E10, E12, E14, E16, E18 & E20
- 1 x 1/2" Drive socket rail & clip – 230mm



Item Code	Bishops Code
4106PR	61048750

4 PIECE 1/2" DRIVE SPLINE BIT SOCKET RAIL SET – METRIC



- Weight: 0.46kg
- Includes:**
- 4 x 1/2" Drive spline bit sockets – 6, 8, 10 & 12mm
- 1 x 1/2" Drive socket rail & clip – 127mm



Item Code	Bishops Code
4136PR	61052321

3/8" DRIVE INHEX BIT SOCKETS – METRIC



- Socket made from chrome vanadium alloy steel
- Bit made from silicon alloy steel (S2)
- Polished, chrome plated
- DIN 7422/3120



Item Code	Size	Length	Weight	Bishops Code
302503	3mm	50mm	28g	61040103
302504	4mm	50mm	30g	61040104
302505	5mm	50mm	34g	61040105
302506	6mm	50mm	38g	61040106
302507	7mm	50mm	38g	61040107
302508	8mm	50mm	40g	61040108
302510	10mm	50mm	40g	61040110
302512	12mm	50mm	42g	61040112

1/2" DRIVE INHEX BIT SOCKETS – METRIC



- Socket made from chrome vanadium alloy steel
- Bit made from silicon alloy steel (S2)
- Polished, chrome plated
- DIN 7422



Item Code	Size	Length	Weight	Bishops Code
402503	3mm	60mm	68g	61048103
402504	4mm	60mm	68g	61048104
402505	5mm	60mm	70g	61048105
402506	6mm	60mm	72g	61048106
402507	7mm	60mm	75g	61048107
402508	8mm	60mm	75g	61048108
402510	10mm	60mm	85g	61048110
402512	12mm	60mm	117g	61048112
402514	14mm	60mm	120g	61048114
402517	17mm	66mm	153g	61048117
402519	19mm	66mm	225g	61048119

3/4" DRIVE INHEX BIT SOCKETS – METRIC



- Socket made from chrome vanadium alloy steel
- Bit made from silicon alloy steel (S2)
- Polished, chrome plated
- Hexagon head
- DIN 7422



Item Code	Size	Length	Weight	Bishops Code
602514	14mm	80mm	257g	61048120
602517	17mm	80mm	268g	61048121
602519	19mm	80mm	278g	61048122
602522	22mm	80mm	361g	61048123

3/8" DRIVE TORX BIT SOCKETS

- Socket made from chrome vanadium alloy steel
- Bit made from silicon alloy steel (S2)
- Polished, chrome plated
- For Torx internal screw
- DIN 3120



Item Code	Size	Length	Weight	Bishops Code
302310	T10	50mm	28g	61040810
302315	T15	50mm	28g	61040815
302320	T20	50mm	30g	61040820
302325	T25	50mm	34g	61040825
302327	T27	50mm	38g	61040827
302330	T30	50mm	38g	61040830
302340	T40	50mm	40g	61040840
302345	T45	50mm	40g	61040845
302350	T50	50mm	42g	61040850

3/8" DRIVE STAR SOCKETS

- For Torx external screws
- Chrome vanadium alloy steel
- Polished, chrome plated
- 4 ball retaining grooves
- DIN 3120

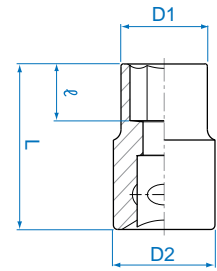

Item Code	Size	D1	D2	ℓ	Length	Weight	Bishops Code
337504M	E4	6mm	16.8mm	3.6mm	28mm	18g	61040704
337505M	E5	7mm	16.8mm	4mm	28mm	19g	61040705
337506M	E6	8mm	16.8mm	5mm	28mm	20g	61040706
337507M	E7	8.9mm	16.8mm	6mm	28mm	21g	61040707
337508M	E8	10mm	16.8mm	6.5mm	28mm	21g	61040708
337510M	E10	12mm	16.8mm	7mm	28mm	22g	61040710
337512M	E12	14.3mm	16.8mm	9mm	28mm	25g	61040712
337514M	E14	15.9mm	17.8mm	9.5mm	28mm	29g	61040714
337516M	E16	18mm	19.8mm	10.5mm	28mm	39g	61040716
337518M	E18	20mm	21.8mm	11mm	28mm	50g	61040718

1/2" DRIVE TORX BIT SOCKETS

- Socket made from chrome vanadium alloy steel
- Bit made from silicon alloy steel (S2)
- Polished, chrome plated
- For Torx internal screw
- DIN 3120



Item Code	Size	Length	Weight	Bishops Code
402320	T20	60mm	72g	61048820
402325	T25	60mm	72g	61048825
402327	T27	60mm	72g	61048827
402330	T30	60mm	75g	61048830
402340	T40	60mm	80g	61048840
402345	T45	60mm	82g	61048845
402350	T50	60mm	85g	61048850
402355	T55	60mm	115g	61048855
402360	T60	60mm	116g	61048860

1/2" DRIVE STAR SOCKETS

- For Torx external screws
- Chrome vanadium alloy steel
- Polished, chrome plated
- 4 ball retaining grooves
- DIN 3120

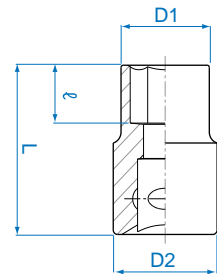

Item Code	Size	D1	D2	ℓ	Length	Weight	Bishops Code
437510M	E10	13.2mm	23.8mm	7.5mm	37mm	60g	61048710
437512M	E12	15mm	23.8mm	9mm	37mm	62g	61048712
437514M	E14	16.4mm	23.8mm	10mm	37mm	64g	61048714
437516M	E16	18.8mm	23.8mm	11mm	37mm	68g	61048716
437518M	E18	20.5mm	23.8mm	12.5mm	72mm	72g	61048718
437520M	E20	22.8mm	23.8mm	14mm	74mm	74g	61048720

GET MORE AT BISHOPS

PICK-UP TOOLS

Page 240

1/2" DRIVE SPLINE BIT SOCKETS – METRIC

- Socket made from chrome vanadium alloy steel
- Bit made from silicon alloy steel (S2)
- Polished, chrome plated
- DIN 3120



Item Code	Size	Length	Weight	Bishops Code
402605	M5	60mm	70g	61048605
402606	M6	60mm	72g	61048606
402608	M8	60mm	73g	61048608
402610	M10	60mm	85g	61048610
402612	M12	60mm	113g	61048612
402614	M14	60mm	117g	61048614



SPECIALTY CHROME SOCKETS

HAND & CUTTING TOOLS

3/8" DRIVE RIBE BIT SOCKETS – METRIC

- Socket made from chrome vanadium alloy steel
- Bit made from silicon alloy steel (S2)
- Polished, chrome plated
- Use for VW, Audi and Fiat cylinder head bolts
- DIN 3120



Item Code	Size	Length	Weight	Bishops Code
303905	M5	90mm	69g	61040905
303906	M6	90mm	71g	61040906
303907	M7	90mm	72g	61040907
303908	M8	90mm	88g	61040908

1/2" DRIVE RIBE BIT SOCKETS – METRIC

- Socket made from chrome vanadium alloy steel
- Bit made from silicon alloy steel (S2)
- Polished, chrome plated
- Use for VW, Audi and Fiat cylinder head bolts



Item Code	Size	Length	Weight	Bishops Code
404910	M10	100mm	106g	61048910
404912	M12	100mm	132g	61048912
404913	M13	100mm	162g	61048913
484914	M14	100mm	164g	61048914
404916	M16	100mm	166g	61048916

1/2" DRIVE SLOTTED BIT SOCKETS

- Socket made from chrome vanadium alloy steel
- Bit made from silicon alloy steel (S2)
- Polished, chrome plated
- DIN 5264/3120



Item Code	Tip Width	Tip Thickness	Length	Weight	Bishops Code
402208	8mm	1.2mm	60mm	77g	61048410
402210	10mm	1.6mm	60mm	83g	61048430
402212	12mm	2mm	60mm	110g	61048450
402214	14mm	2.5mm	60mm	112g	61048470

3/8" DRIVE SLOTTED BIT SOCKETS

- Socket made from chrome vanadium alloy steel
- Bit made from silicon alloy steel (S2)
- Polished, chrome plated
- DIN 2380



Item Code	Tip Width	Tip Thickness	Length	Weight	Bishops Code
302205	5mm	1mm	50mm	36g	61040410
302208	8mm	1.2mm	50mm	37g	61040430
302210	10mm	1.6mm	50mm	38g	61040450

1/2" DRIVE PHILLIPS BIT SOCKETS

- Socket made from chrome vanadium alloy steel
- Bit made from silicon alloy steel (S2)
- Polished, chrome plated
- Phillips head
- DIN ISO 8764-1



Item Code	Size	Length	Weight	Bishops Code
402102	PH2	60mm	77g	61048310
402103	PH3	60mm	77g	61048330
402104	PH4	60mm	77g	61048350

3/8" DRIVE PHILLIPS BIT SOCKETS – METRIC

- Socket made from chrome vanadium alloy steel
- Bit made from silicon alloy steel (S2)
- Polished, chrome plated
- Phillips head
- Length: 50mm
- DIN ISO 8764-1



Item Code	Size	Length	Weight	Bishops Code
302102	PH2	50mm	35g	61040310
302103	PH3	50mm	36g	61040330
302104	PH4	50mm	37g	61040350

3/8" DRIVE 6 POINT MAGNETIC SPARK PLUG SOCKETS

- Magnetic inside sleeve
- DIN 3120

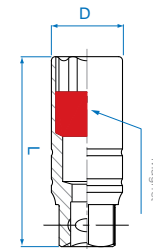

Item Code	Size	Dia.	Length	Weight	Bishops Code
366516	16mm (5/8")	21mm	70mm	105g	61040562
366021	20.8mm (13/16")	27.7mm	70mm	155g	61040587

1/2" DRIVE 6 POINT MAGNETIC SPARK PLUG SOCKETS

- Chrome vanadium alloy steel, polished, chrome plated
- 4 ball retaining grooves
- Magnetic inside sleeve
- Length: 70mm
- DIN 3120



Item Code	Size	Dia.	Length	Weight	Bishops Code
466516	16mm (5/8")	20.75mm	70mm	115g	61048562
466021	20.8mm (13/16")	27.7mm	70mm	165g	61048581



THE USUAL SUSPECTS WRENCHES & SPANNERS

Terms & Definitions

You might call a spade a spade, but there are a lot of different terms floating around for wrenches and spanners.



1 A **Socket Ratchet** is essentially a handle with a ratcheting male square drive of variable size. Combined with a set of standard sockets, you can tackle many different fastener sizes.

2 A **Torque Wrench** is similar to a socket wrench, however is precisely calibrated to apply an adjustable amount of torque.

3 A **Spanner** is a tool with fixed capacity, available in single or double ended varieties. The most common are combination spanners, which combine open jaws with a ring. Spanners with two open jaw ends or two ring ends are also available. Slogging spanners are designed to be struck with a hammer to loosen the most stubborn bolts.

4 An **Adjustable Wrench** is similar to an open-ended spanner with jaws that can expand and contract. An essential and indispensable tool.

If a tool is **ratcheting**, this means it has a mechanism to allow back and forth movement during fastening or loosening. This removes the need to reset the tool in-between turns.

If you can't find what you need in this catalogue, make sure to contact Bishops and we will find it for you.

REVERSIBLE SOCKET RATCHETS

- Chrome vanadium alloy steel handle
- (Gear) driver of chrome molybdenum steel
- Polished, chrome plated black driver by phosphate sunk



Item Code	Size	Gear Action	Teeth	Length	Weight	Bishops Code
2769-55P	¼" Drive	15°	24	140mm	125g	61034120
3769-08P	¾" Drive	11°	32	200mm	358g	61042120
3781-11P	¾" Drive	11°	32	280mm	445g	61042156
3779-08G	¾" Drive	11°	32	200mm	295g	61042140
3755-08G	¾" Drive	5°	72	200mm	387g	61042150
4768-10F	½" Drive	11°	32	250mm	589g	61050120
4768-10P	½" Drive	11°	32	250mm	562g	61050160
4789-12P	½" Drive	11°	32	300mm	735g	61050176
4779-10G	½" Drive	11°	32	250mm	580g	61050140
4755-10G	½" Drive	5°	72	250mm	570g	61050170
6779-20F	¾" Drive	15°	24	500mm	2.35kg	61058120
8779-32F	1" Drive	15°	24	800mm	4.40kg	61066120

¾" DRIVE SOCKET RATCHET REPAIR KIT



- Repair kit to suit 6779-20F (61058120)



Item Code	Bishops Code
6779-DK	61058125



SOCKET RATCHET, WRENCHES & HANDLES

HAND & CUTTING TOOLS

1/2" DRIVE 72 TEETH MINI REVERSIBLE SOCKET RATCHET

- Chrome vanadium alloy steel handle
- Chrome molybdenum steel (gear) driver
- Polished, chrome plated finish
- Black driver by phosphate sunk
- Mini reversible ratchet
- 5° gear action degree (72 teeth)
- Two teeth pawl action
- Overall length: 137mm (5 1/2")
- DIN 3122



Item Code	Bishops Code
4760-5G	61050118



FLEXIBLE HANDLES

- Chrome vanadium alloy steel
- Polished, chrome plated finishing and black phosphate sunk
- Action degree: 180°



3452-08F

Item Code	Size	Length	Weight	Bishops Code
3452-08F	3/8" Drive	215mm	259g	61042180
4453-15F	1/2" Drive	375mm	630g	61050200
4453-18F	1/2" Drive	450mm	708g	61050220
6452-18F	3/4" Drive	450mm	1.717kg	61058380
6452-30F	3/4" Drive	760mm	2.813kg	61058385
6452-DK	Repair Kit for 3/4" Flex Handle Ratchet			61058389



GET MORE AT BISHOPS



MULTI-PURPOSE LUBRICANTS

Page 442

PODGING WRENCHES

- Made from special forged steel
- Hardness > 40HRC



Item Code	Size	Length	Bishops Code
65076	M17-19mm	320mm	61095510
65077	M19-22mm	320mm	61095515
65081	M36-41mm	480mm	61095535

DOUBLE SOCKET PODGING WRENCHES

- High quality drop forged chrome vanadium steel
- Can be used as ratchet and socket wrench
- Reversible switch for tightening or loosening nuts and bolts
- Tapered end to align soft holes easily
- Combination double socket two sizes in one built in ratchet
- 32 teeth



Item Code	Size	Bishops Code	Item Code	Size	Bishops Code
15001012P	M10 x 12mm	61094796	15002224P	M22 x 24mm	61094802
15001317P	M13 x 17mm	61094797	15002430P	M24 x 30mm	61094803
15001719P	M17 x 19mm	61094798	15002730P	M27 x 30mm	61094804
15001921P	M19 x 21mm	61095512	15002732P	M27 x 32mm	61094805
15001922P	M19 x 22mm	61094800	15003236P	M32 x 36mm	61094806
15001924P	M19 x 24mm	61094801	15003641P	M36 x 41mm	61094807

1/2" DRIVE FLEXIBLE HANDLE

- Chrome vanadium alloy steel construction
- Polished, chrome plated finish
- Flexible handle
- 180° action
- DIN 3122



Item Code	Length	Weight	Bishops Code
4462-18F	463mm (18")	1.046kg	61050226
4462-24F	613mm (24")	1.350kg	61050225

DRIVE SLIDING T-HANDLES

- Chrome vanadium alloy steel
- Polished, chrome plated finishing and black phosphate sunk



3571-08

4573-10

Item Code	Size	Length	Weight	Bishops Code
3571-08	3/8" Drive	200mm	182g	61042160
4572-10	1/2" Drive	250mm	371g	61050240
6572-20	3/4" Drive	500mm	1.542kg	61058160
8572-25	1" Drive	630mm	4.20kg	61066140

90° L-HANDLES

- Made from chrome vanadium alloy steel
- Polished, chrome plated finish
- 4 ball retaining grooves



6581-18

Item Code	Size	Length	Weight	Bishops Code
4581-10	1/2" Drive	250mm	429g	61050180
6581-18	3/4" Drive	450mm	1.85kg	61058180

1/2" DRIVE SPEED BRACE

- Chrome vanadium alloy steel
- Polished, chrome plated finishing
- Length: 412mm
- Weight: 545g



Item Code	Bishops Code
4311-16G	61050250

EXTENSION BARS

- Chrome vanadium alloy steel
- Polished, chrome plated finishing

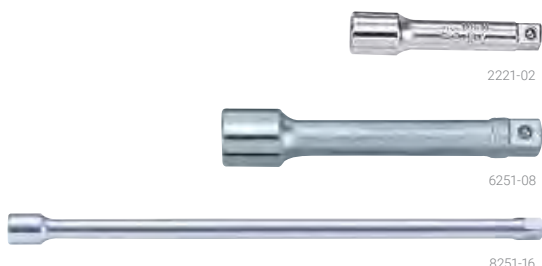

Item Code	Size	Length	Weight	Bishops Code
2221-02	1/4" Drive	50mm	24g	61034320
2221-04	1/4" Drive	100mm	45g	61034340
2221-06	1/4" Drive	150mm	67g	61034360
3221-16	3/8" Drive	40mm	39g	61042320
3221-03	3/8" Drive	75mm	75g	61042340
3221-06	3/8" Drive	150mm	146g	61042360
3221-10	3/8" Drive	250mm	240g	61042380
4223-02	1/2" Drive	50mm	94g	61050320
4251-03	1/2" Drive	75mm	138g	61050330
4251-05	1/2" Drive	125mm	192g	61050350
4223-05	1/2" Drive	125mm	198g	61050355
4251-06	1/2" Drive	150mm	230g	61050360
4251-10	1/2" Drive	250mm	433g	61050380
4223-10	1/2" Drive	250mm	357g	61050390
6251-04	3/4" Drive	100mm	400g	61058320
6251-08	3/4" Drive	200mm	732g	61058340
6251-16	3/4" Drive	400mm	1,362g	61058360
8251-08	1" Drive	200mm	1,350g	61066320
8251-16	1" Drive	400mm	2,480g	61066360

TAIWAN FOR TOOLS!

Did you know that Taiwan is the manufacturing nation of choice when it comes to tools?

Large brands including King Tony and Sidchrome now source many of their tools from this country.

UNIVERSAL JOINTS



- Chrome vanadium alloy steel, polished, chrome plated
- 4 ball retaining grooves



Item Code	Size	Length	Weight	Bishops Code
2792	1/4" Drive	36mm	29g	61034560
3792	3/8" Drive	50mm	67g	61042580
4791	1/2" Drive	77.5mm	163g	61050560
6791	3/4" Drive	108mm	590g	61058580

ADAPTORS



- Chrome vanadium alloy steel
- Polished, chrome plated finishing



Item Code	Size	Weight	Bishops Code
2813	1/4" F x 3/8" M	20g	61034520
3812	3/8" F x 1/4" M	31.5g	61042520
3814	3/8" F x 1/2" M	47g	61042540
4813	1/2" F x 3/8" M	61g	61050520
4816	1/2" F x 3/4" M	114g	61050540
6814	3/4" F x 1/2" M	131g	61058520
6818	3/4" F x 1" M	304g	61058540
8816	1" F x 3/4" M	330g	61066520

SOCKET & BIT HOLDERS



- For use with 10, 13 and 19mm ratchet wrenches



Item Code	Description	To Suit Ratchet Wrench	Bishops Code
373202H	1/4" Bit	10mm	61085901
373202R	1/4" Drive	10mm	61085905
373203R	3/8" Drive	13mm	61085908
373225H	5/16" Bit	13mm	61085910
373204R	1/2" Drive	19mm	61085915

GET MORE AT BISHOPS

MECHANICS GLOVES

Page 7



SOCKET WRENCHES, IMPACT DRIVERS & ACCESSORIES

HAND & CUTTING TOOLS

12 PIECE ANGLED SOCKET WRENCH SET – METRIC



- Weight: 4.75kg
- Includes:
 - 12 x Angled socket wrenches – 8, 10, 11, 12, 13, 14, 16, 17, 18, 19, 22 & 24mm



Item Code	Bishops Code
1812MR	61094910

12 & 6 POINT ANGLED SOCKET WRENCHES – METRIC



- Angle and through-hole design
- High quality steel, chrome plated
- Deep recess at one side and open end socket at the other, easily fit over protruding studs
- ISO 2236



Item Code	Size	Length	Weight	Bishops Code
1080-08	8mm	120mm	62g	61094808
1080-10	10mm	130mm	100g	61094810
1080-11	11mm	135mm	115g	61094811
1080-12	12mm	140mm	155g	61094812
1080-13	13mm	150mm	180g	61094813
1080-14	14mm	160mm	185g	61094814
1080-16	16mm	185mm	285g	61094815
1080-17	17mm	195mm	315g	61094817
1080-18	18mm	210mm	370g	61094818
1080-19	19mm	215mm	425g	61094819
1080-22	22mm	245mm	530g	61094822
1080-24	24mm	265mm	670g	61094824

1/4" DRIVE DRIVING HANDLE



- Chrome vanadium alloy steel
- Polished, chrome plated finishing and black phosphate sunk
- Length: 150mm
- Weight: 76g



Item Code	Bishops Code
2178AE	61034160

1/2" DRIVE SQUARE T-SHAPED DRIVER



- Chrome vanadium alloy steel
- 170mm handle
- Length: 268mm
- Weight: 400g



Item Code	Bishops Code
4511-06	61050235

6 PIECE 1/2" DRIVE IMPACT DRIVER SET



- Metal case size: 190(l) x 60(w) x 48(h)mm
- Weight: 1kg
- Includes:
 - 2 x 5/16" Hex size shank drivers (Phillips head) – 2 & 3mm
 - 2 x 5/16" Hex size shank drivers (slotted head) – 9 & 11mm
 - 1 x 1/2" Drive impact driver
 - 1 x 1/2" Drive bit holder



Item Code	Bishops Code
4112FR	61006100

10 PIECE 1/2" DRIVE IMPACT DRIVER & SOCKET SET



- Metal case size: 246(l) x 103(w) x 38(h)mm
- Weight: 1.56kg
- Includes:
 - 2 x 5/16" Hex size shank drivers (Phillips head) – 2 & 3mm
 - 2 x 5/16" Hex size shank drivers (slotted head) – 9 & 11mm
 - 4 x 1/2" Drive 6 point metric standard sockets – 8, 10, 12 & 14mm
 - 1 x 1/2" Drive impact driver
 - 1 x 1/2" Drive bit holder



Item Code	Bishops Code
4505MR	61006110

TORQUE ANGLE GAUGES



- Square drive
- 360° angle scale – clearly marked in 2° increments, and in intervals of 10° and 30°
- Indicator etched on clear plastic plate – protects angle scale from dirt and grease
- Adjustable arm keeps angle scale stationary
- Arm has two lengths for additional flexibility in placement against components
- Tough composite dial and rotating index allow operator to accurately tighten fixing to manufacturers exact standard



Item Code	Size	Bishops Code
34440	1/2" x 1/2"	63070320
34660	3/4" x 3/4"	63070322

GET MORE AT BISHOPS



HYDRAULIC TORQUE WRENCHES

Page 474

TORQUE WRENCHES

- Dual scale – English and Newton meter (in. lb./ft. lb. and Nm)
- Automatic quick return for torque-adjusting
- Comfortable rubber handle
- Distinct laser scale
- Quick release reversible ratchet
- Accuracy ±3% complies to all International Standards – DIN ISO 6789 and ASME B107.14M-2004



Item Code	Square Drive	Torque Range	Length	Bishops Code
34262-1CG	¼"	30–200in.lb. (4–22Nm)	324mm	63070020
34362-2CG	⅜"	10–80ft.lb. (16.9–105Nm)	435mm	63070040
34462-1CG	½"	20–150ft.lb. (34–197Nm)	521mm	63070092
34462-2CG	½"	30–250ft.lb. (47–332Nm)	613mm	63070090
34662-1CG	¾"	50–450ft.lb. (102–576Nm)	1,048mm	63070160
34662-3CG	¾"	150–750ft.lb. (237–983Nm)	1,238mm	63070180
34862-1CG	1"	150–750ft.lb. (237–983Nm)	1,238mm	63070200

½" SQUARE DRIVE PROFESSIONAL ADJUSTABLE TORQUE WRENCH

- Dual scale
- English and Kilogram-force Centimetre/Kilogram-force meter (in.lb./ft.lb. and kgf.cm/kgf.m)
- Torque range: 10–150 ft.lb. (1.4–20.7kgf.m)
- Tolerance of torque: ±4%
- Increments: 1ft.lb. (0.14kgf.m)
- Length: 450mm
- Weight: 1.34kg
- Quality accords to DIN ISO 6789 and ASME B107.14M-2004



Item Code	Bishops Code
34423-1B	63070110

½" SQUARE DRIVE ELECTRONIC TORQUE WRENCH

- Electronic torque value readout
- CW ±2% and CCW ±3% operation
- Quality accords to DIN ISO 6789-2003 and ASME B107.28-2005
- Peak hold and track mode selectable
- Buzzer and LED indicator for presettable target torque
- Engineering units (Nm, ft.lb, in.lb, kgf.cm, kgf.m) selectable
- Auto shut-off after about 80 seconds
- Length: 530mm
- Weight: 1.5kg
- Torque range:**
- 40–200 Nm
- 29.5–147.5 ft.lb
- 354–1,770 in.lb.
- 408–2,038 kgf.cm
- 4.08–20.38 kgf.m

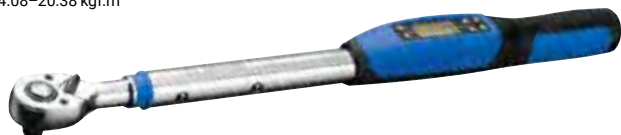

Item Code	Bishops Code
34467-1AG	63070094



¾" SQUARE DRIVE ELECTRONIC TORQUE WRENCH

- Electronic torque value readout
- CW ±2% and CCW ±3% operation
- Quality accords to DIN ISO 6789-2003 and ASME B107.28-2005
- Peak hold and track mode selectable
- Buzzer and LED indicator for presettable target torque
- Engineering units (Nm, ft.lb, in.lb, kgf.cm, kgf.m) selectable
- Auto shut-off after about 80 seconds
- Length: 460mm
- Weight: 1.4kg
- Torque range:**
- 27–135 Nm
- 19.9–99.6 ft.lb
- 239–1,195 in.lb.
- 275–1,376 kgf.cm
- 2.75–13.76 kgf.m



Item Code	Bishops Code
34367-2AG	63070044



11 PIECE INTERCHANGEABLE TORQUE WRENCH SET – METRIC

- Weight: 4kg
- Includes:**
- 9 x Open ended insert tools – 13, 14, 15, 17, 19, 22, 24, 27 & 30mm
- 1 x Ratchet insert tool
- 1 x Industry quality interchangeable 14 x 18mm torque wrench (English)



Item Code	Bishops Code
345203E11MR	63070310



TORQUE MULTIPLIER

- Torque multiplication with 1:5 accuracy guaranteed better than ±5%
- Reaction bar supplied in two styles for maximum versatility
- Minimal maintenance and extended life
- Supplied in convenient carry case
- Ratio: 1:5
- Input square: ¾"
- Output square: 1"
- Max. input torque: 540Nm (400lbf.ft)
- Max. output torque: 2,700Nm (2,000lbf.ft)
- Weight: 7.4kg



Item Code	Bishops Code
34688	63070925





SPEED RATCHET, RING & COMBINATION SPANNER SETS

HAND & CUTTING TOOLS

7 PIECE SPEED RATCHET SET – METRIC



- Weight: 0.91kg
- Includes:**
- Sizes; 10, 11, 12, 14, 15, 17 & 19mm



Item Code	Bishops Code
12107MR	61082305

14 PIECE SPEED RATCHET SET – METRIC



- Weight: 2.5kg
- Includes:**
- Sizes: 8, 9, 10, 11, 12, 13, 14, 15, 16, 17, 18, 19, 22 & 24mm



Item Code	Bishops Code
12114MR	61082306

6 PIECE OFFSET RING SPANNER SET – METRIC



- Ideal for crowded or tight spaces
- Ultra-compact ring head
- Chrome vanadium steel
- Chrome plated
- Metric size - DIN 3113
- Includes:**
- Sizes: 10 x 11, 12 x 14, 13 x 15, 16 x 18, 17 x 19 & 22 x 24mm



Item Code	Bishops Code
1F06MRN	61090310

8 PIECE 75° OFFSET RING SPANNER SET – METRIC



- Weight: 1.43kg
- Includes:**
- Sizes: 6 x 7, 8 x 9, 10 x 11, 12 x 13, 14 x 15, 16 x 17, 18 x 19 & 21 x 23mm



Item Code	Bishops Code
1708MR	61090308

12 PIECE 75° OFFSET RING SPANNER SET – METRIC



- 75° Offset
- Chrome vanadium alloy steel
- Comes in canvas tool roll
- DIN 837
- Includes:**
- Sizes: 6 x 7, 8 x 9, 10 x 11, 12 x 13, 14 x 15, 16 x 17, 18 x 19, 20 x 22, 21 x 23, 24 x 26, 25 x 28 & 30 x 32mm



Item Code	Bishops Code
1712MR	61090400

5 PIECE COMBINATION SPANNER SET – METRIC

- Material: chrome vanadium steel
- Chrome plated, mirror polished
- Heat treated and fully polished
- Double dipped grip handle for comfort
- Includes:**
- Sizes: 6, 8, 10, 12 & 15mm



Item Code	Bishops Code
W003308	63521166

6 PIECE COMBINATION SPANNER SET – METRIC

- Chrome-vanadium steel
- Open end and ring end spanners
- Includes:**
- Sizes: 8, 10, 12, 14, 16 & 18mm



Item Code	Bishops Code
W003304	63521160

7 PIECE COMBINATION SPANNER SET – METRIC



- Weight: 0.6kg
- Includes:**
- Sizes: 10, 11, 12, 13, 14, 17 & 19mm



Item Code	Bishops Code
1207MR	61082307

7 PIECE COMBINATION SPANNER SET – IMPERIAL



- Weight: 0.6kg
- Includes:
- Sizes: 3/8", 7/16", 1/2", 9/16", 5/8", 11/16" & 3/4"



Item Code	Bishops Code
1207SR	61082107

14 PIECE COMBINATION SPANNER SET – METRIC



- European slimline type
- 15° open ended angle
- 15° ring end offset from shaft
- Chrome vanadium alloy steel and chrome plated
- Comes in canvas tool roll
- Includes:
- Sizes: 6, 7, 8, 9, 10, 11, 12, 13, 14, 15, 16, 17, 18 & 19mm



Item Code	Bishops Code
1214MRN05	61082312

11 PIECE COMBINATION SPANNER SET – METRIC



- Weight: 1.4kg
- Includes:
- Sizes: 8, 9, 10, 11, 12, 13, 14, 17, 19, 22 & 24mm



Item Code	Bishops Code
1211MR	61082311

14 PIECE COMBINATION SPANNER SET – IMPERIAL



- Weight: 2.7kg
- Includes:
- Sizes: 5/16", 3/8", 7/16", 1/2", 9/16", 5/8", 11/16", 3/4", 13/16", 7/8", 15/16", 1", 1 1/8" & 1 1/4"



Item Code	Bishops Code
1214SR	61082114

11 PIECE COMBINATION SPANNER SET – IMPERIAL



- Weight: 1.4kg
- Includes:
- Sizes: 1/4", 5/16", 3/8", 7/16", 1/2", 9/16", 11/16", 3/4", 13/16", 7/8" & 15/16"



Item Code	Bishops Code
1211SR	61082111

15 PIECE COMBINATION SPANNER SET – METRIC



- Weight: 1.63kg
- Includes:
- Sizes: 8, 9, 10, 11, 12, 13, 14, 15, 16, 17, 19, 21, 22 & 24mm



Item Code	Bishops Code
1215MR	61082315

14 PIECE COMBINATION SPANNER SET – METRIC



- Weight: 2.7kg
- Includes:
- Sizes: 10, 11, 12, 13, 14, 16, 17, 19, 21, 22, 24, 27, 30 & 32mm



Item Code	Bishops Code
1214MR	61082314

18 PIECE COMBINATION SPANNER SET – METRIC



- Weight: 2.5kg
- Includes:
- Sizes: 6, 7, 8, 9, 10, 11, 12, 13, 14, 15, 16, 17, 18, 19, 20, 21, 22 & 24mm



Item Code	Bishops Code
1218MRN	61082318



COMBINATION, OPEN END & FLARE NUT SPANNER SETS

HAND & CUTTING TOOLS

26 PIECE COMBINATION SPANNER SET – METRIC



- Chrome vanadium alloy steel
- Satin finish
- Comes in canvas tool roll

Includes:

- Sizes: 6, 7, 8, 9, 10, 11, 12, 13, 14, 15, 16, 17, 18, 19, 20, 21, 22, 23, 24, 25, 26, 27, 28, 29, 30 & 32mm



Item Code

1226MR

Bishops Code

61082326

8 PIECE OPEN END SPANNER SET – METRIC



- Weight: 910kg

Includes:

- Sizes: 6 x 7, 8 x 9, 10 x 11, 12 x 13, 14 x 15, 16 x 17, 18 x 19 & 20 x 22mm



Item Code

1108MR

Bishops Code

61086308

8 PIECE OPEN ENDED SPANNER SET – IMPERIAL



- Weight: 910g

Includes:

- Sizes: 1/4 x 5/16", 5/16 x 3/8", 3/8 x 7/16", 7/16 x 1/2", 9/16 x 5/8", 5/8 x 11/16", 11/16 x 3/4" & 13/16 x 7/8"



Item Code

1108SR

Bishops Code

61086108

9 PIECE OPEN-END SPANNER SET – METRIC

- Material: chrome vanadium steel
- Chrome plated, mirror polished

Includes:

- Sizes: 6 x 7, 8 x 9, 10 x 11, 12 x 13, 14 x 15, 16 x 17, 18 x 19, 20 x 22 & 21 x 23mm



Item Code

W003306

Bishops Code

63521163

12 PIECE OPEN END SPANNER SET – METRIC



- Weight: 2.35kg

Includes:

- Sizes: 6 x 7, 8 x 9, 10 x 11, 12 x 13, 14 x 15, 16 x 17, 18 x 19, 20 x 22, 21 x 23, 24 x 27, 25 x 28 & 30 x 32mm



Item Code

1112MR

Bishops Code

61086312

12 PIECE OPEN END SPANNER SET – IMPERIAL



- Weight: 2.35kg

Includes:

- Sizes: 1/4 x 5/16", 5/16 x 3/8", 3/8 x 7/16", 7/16 x 1/2", 9/16 x 5/8", 5/8 x 11/16", 11/16 x 3/4", 13/16 x 7/8", 15/16 x 1", 15/16 x 1 1/16", 1 x 1 1/8" & 1 1/8 x 1 1/4"



Item Code

1112SR

Bishops Code

61086112

6 PIECE FLARE NUT SPANNER SETS – METRIC & IMPERIAL



- 6 points
- 12° ring offset
- Chrome vanadium alloy steel
- Chrome plated
- DIN 3118

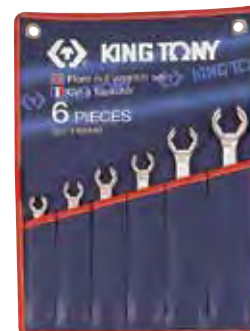

Item Code

1306SR

Includes

5/16" x 3/8", 3/8" x 7/16", 1/2" x 9/16", 9/16" x 5/8", 11/16" x 3/4" & 3/4" x 7/8"

Weight

0.86kg

Bishops Code

61094004

Item Code

1306MR

8 x 10mm, 10 x 12mm, 11 x 13mm, 12 x 14mm, 17 x 19mm & 19 x 22mm

Weight

0.90kg

Bishops Code

61094008

OPEN-ENDED & RATCHET RING SPANNERS – METRIC



- Polished with chrome finish
- 5° gear action (72 teeth)



Item Code	Size	Length	Weight	Bishops Code
373108M	8mm	140mm	25g	61085080
373110M	10mm	158mm	40g	61085100
373111M	11mm	165mm	60g	61085110
373112M	12mm	171mm	75g	61085120
373113M	13mm	178mm	80g	61085130
373114M	14mm	190mm	100g	61085140
373115M	15mm	199mm	115g	61085150
373117M	17mm	225mm	165g	61085170
373119M	19mm	247mm	225g	61085190

COMBINATION SPANNERS – METRIC



- European slimline type
- 15° open ended angle
- 15° ring end offset from shaft
- Chrome vanadium alloy steel
- Chrome plated
- Metric size: DIN3113, ISO7738



Item Code	Size	Length	Weight	Bishops Code
1060-06	6mm	105mm	18g	61084006
1060-07	7mm	115mm	20g	61084007
1060-08	8mm	125mm	25g	61084008
1060-09	9mm	135mm	34g	61084009
1060-10	10mm	145mm	39g	61084010
1060-11	11mm	155mm	46g	61084011
1060-12	12mm	165mm	56g	61084012
1060-13	13mm	175mm	69g	61084013
1060-14	14mm	185mm	80g	61084014
1060-15	15mm	195mm	93g	61084015
1060-16	16mm	205mm	111g	61084016
1060-17	17mm	215mm	119g	61084017
1060-18	18mm	225mm	138g	61084018
1060-19	19mm	235mm	158g	61084019
1060-20	20mm	245mm	182g	61084020
1060-21	21mm	255mm	203g	61084021
1060-22	22mm	265mm	225g	61084022
1060-23	23mm	275mm	251g	61084023
1060-24	24mm	285mm	287g	61084024
1060-25	25mm	295mm	326g	61084025
1060-26	26mm	305mm	344g	61084026
1060-27	27mm	315mm	371g	61084027
1060-28	28mm	325mm	387g	61084028
1060-29	29mm	335mm	456g	61084029
1060-30	30mm	345mm	514g	61084030
1060-32	32mm	365mm	557g	61084032

GET MORE AT BISHOPS

SAFETY STEPS

Page 359



THREAD LOCKERS

Page 468

HEX NUTS

Page 283



JUMBO TYPE COMBINATION SPANNERS – METRIC



- 15° open ended angle
- 15° ring end offset from shaft
- Medium carbon steel
- Polished, chrome plated
- Metric size: DIN3113, ISO7738



Item Code	Size	Length	Weight	Bishops Code
1071-33	33mm	420mm	0.765kg	61084033
1071-34	34mm	420mm	0.745kg	61084034
1071-35	35mm	430mm	0.960kg	61084035
1071-36	36mm	430mm	0.960kg	61084036
1071-38	38mm	455mm	1.15kg	61084038
1071-41	41mm	495mm	1.40kg	61084041
1071-42	42mm	495mm	1.39kg	61084042
1071-44	44mm	500mm	1.47kg	61084044
1071-46	46mm	500mm	1.51kg	61084046
1071-48	48mm	565mm	2.55kg	61084048
1071-50	50mm	565mm	2.55kg	61084050



COMBINATION, OPEN END & OFFSET RING SPANNERS

HAND & CUTTING TOOLS

COMBINATION SPANNERS – IMPERIAL

- European slimline type
- 15° open ended angle
- 15° ring end offset from shaft
- Chrome vanadium alloy steel
- Chrome plated
- Imperial size: ANSI/ASME B107.6



Item Code	Size	Length	Weight	Bishops Code
5060-08	¼"	105mm	18g	61083025
5060-10	⅝ ₁₆ "	125mm	25g	61083031
5060-12	⅜"	145mm	39g	61083037
5060-14	7 ₁₆ "	155mm	46g	61083043
5060-16	½"	175mm	69g	61083050
5060-18	9 ₁₆ "	185mm	80g	61083056
5060-20	⅝"	205mm	111g	61083062
5060-22	11 ₁₆ "	215mm	119g	61083068
5060-24	¾"	235mm	158g	61083075
5060-26	13 ₁₆ "	255mm	203g	61083081
5060-28	7 ₈ "	265mm	220g	61083087
5060-30	15 ₁₆ "	285mm	287g	61083093
5060-32	1"	295mm	326g	61083100
5060-34	1 1 ₁₆ "	315mm	371g	61083106
5060-36	1 ⅜"	335mm	456g	61083112
5060-40	1 ¼"	365mm	557g	61083125

JUMBO TYPE COMBINATION SPANNERS – IMPERIAL

- 15° open ended angle
- 15° ring end offset from shaft
- Medium carbon steel
- Polished, chrome plated
- Imperial size: ANSI/ASME B107.6



Item Code	Size	Length	Weight	Bishops Code
5071-42	1 5 ₁₆ "	415mm	0.76kg	61083131
5071-44	1 ⅜"	425mm	0.97kg	61083137
5071-46	1 7 ₁₆ "	425mm	0.95kg	61083143
5071-48	1 ½"	455mm	1.15kg	61083150
5071-50	1 9 ₁₆ "	500mm	1.54kg	61083156
5071-52	1 ⅝"	500mm	1.40kg	61083162
5071-54	1 11 ₁₆ "	500mm	1.43kg	61083168
5071-56	1 ¾"	500mm	1.41kg	61083175
5071-58	1 15 ₁₆ "	500mm	1.47kg	61083181
5071-60	1 ⅞"	560mm	2.54kg	61083187
5071-62	1 15 ₁₆ "	560mm	2.55kg	61083193
5071-64	2"	560mm	2.54kg	61083200



OPEN END SPANNERS – METRIC

- European slimline type
- 15° open ended angle
- Chrome vanadium alloy steel
- Chrome plated
- Metric size: DIN3110



Item Code	Size	Length	Weight	Bishops Code
19000607	6 x 7mm	123mm	28g	61088006
19000809	8 x 9mm	140mm	39g	61088008
19001011	10 x 11mm	156mm	65g	61088010
19001213	12 x 13mm	172mm	86g	61088012
19001415	14 x 15mm	188.5mm	114g	61088014
19001617	16 x 17mm	204mm	146g	61088016
19001819	18 x 19mm	221mm	178g	61088018
19002022	20 x 22mm	237mm	210g	61088020
19002123	21 x 23mm	247mm	258g	61088021
19002427	24 x 27mm	263mm	326g	61088023
19002426	24 x 26mm	263mm	281g	61088024
19002528	25 x 28mm	279mm	373g	61088025
19002730	27 x 30mm	298mm	458g	61088027
19003032	30 x 32mm	298mm	481g	61088030

OPEN END SPANNERS – IMPERIAL

- European slimline type
- 15° open ended angle
- Chrome vanadium alloy steel
- Chrome plated
- Imperial size: ANSI/ASME B107.6



Item Code	Size	Length	Weight	Bishops Code
59000810	¼" x 5 ₁₆ "	123mm	28g	61087025
59001012	5 ₁₆ " x ⅜"	140mm	39g	61087031
59001214	⅜" x 7 ₁₆ "	156mm	65g	61087037
59001416	7 ₁₆ " x ½"	172mm	78g	61087043
59001820	9 ₁₆ " x ⅝"	188.5mm	114g	61087056
59002022	⅝" x 11 ₁₆ "	204mm	146g	61087062
59002224	11 ₁₆ " x ¾"	221mm	177g	61087068
59002628	13 ₁₆ " x ⅞"	237mm	210g	61087081
59003032	15 ₁₆ " x 1"	247mm	258g	61087090
59003034	15 ₁₆ " x 1 1 ₁₆ "	263mm	281g	61087093
59003236	1" x 1 ⅜"	279mm	373g	61087100
59003640	1 ⅝" x 1 ¼"	298mm	481g	61087112

0° OFFSET RING SPANNERS – METRIC

- Ideal for crowded or tight spaces
- Ultra-compact ring head
- Chrome vanadium steel
- Chrome plated
- Metric size: DIN 3113



Item Code	Size	D1	D2	Length	Weight	Bishops Code
19B01214	12 x 14mm	17.8mm	20.3mm	20.3mm	157g	61092052
19B01315	13 x 15mm	20.2mm	23.3mm	23.3mm	217g	61092054
19B01417	14 x 17mm	20.2mm	23.3mm	23.3mm	217g	61092056
19B01618	16 x 18mm	23.7mm	26.6mm	26.6mm	284g	61092058
19B01719	17 x 19mm	23.7mm	26.6mm	26.6mm	284g	61092060
19B01921	19 x 21mm	27.5mm	29.7mm	29.7mm	376g	61092062



75° OFFSET RING SPANNERS – METRIC

- European slimline type
- Thin wall rings
- Chrome vanadium alloy steel
- Chrome plated
- Metric size: DIN 838
- Imperial size: ANSI/ASME B107.6



Item Code	Size	Length	Weight	Bishops Code
19700607	6 x 7mm	168mm	43g	61092002
19700809	8 x 9mm	183mm	62g	61092004
19700810	8 x 10mm	183mm	62g	61092006
19701011	10 x 11mm	198mm	88g	61092008
19701012	10 x 12mm	198mm	131g	61092010
19701213	12 x 13mm	217mm	131g	61092011
19701214	12 x 14mm	217mm	152g	61092012
19701415	14 x 15mm	239mm	186g	61092013
19701417	14 x 17mm	260mm	189g	61092014
19701617	16 x 17mm	260mm	240g	61092016
19701719	17 x 19mm	292mm	240g	61092017
19701819	18 x 19mm	292mm	330g	61092018
19701921	19 x 21mm	318mm	330g	61092019
19702022	20 x 22mm	318mm	330g	61092020
19702123	21 x 23mm	326.5mm	362g	61092021
19702326	23 x 26mm	344mm	436g	61092022
19702426	24 x 26mm	329mm	436g	61092023
19702427	24 x 27mm	329mm	436g	61092027
19703032	30 x 32mm	362mm	600g	61092032

75° OFFSET RING SPANNERS – IMPERIAL

- European slimline type
- Thin wall rings
- Chrome vanadium alloy steel
- Chrome plated
- Imperial size: ANSI/ASME B107.6



Item Code	Size	Length	Weight	Bishops Code
59700810	¼" x ⅝"	168mm	43g	61091025
59701214	⅜" x 7/16"	198mm	88g	61091037
59701416	7/16" x ½"	217mm	131g	61091043
59701618	½" x 9/16"	217mm	134g	61091050
59701820	9/16" x ⅝"	260mm	152g	61091056
59702022	⅝" x 11/16"	260mm	189g	61091062
59702224	11/16" x ¾"	292mm	240g	61091068
59702428	¾" x 7/8"	318mm	330g	61091075
59703032	15/16" x 1"	329mm	436g	61091093
59703436	1 1/16" x 1 1/8"	347mm	488g	61091106

FLARE NUT SPANNERS – METRIC

- 6 point
- 12° ring offset
- Chrome vanadium alloy steel
- Chrome plated
- DIN 3118



Item Code	Size	Length	Weight	Bishops Code
19300810	8 x 10mm	130mm	53g	61094010
19301011	10 x 11mm	150mm	78g	61094011
19301012	10 x 12mm	150mm	74g	61094012
19301113	11 x 13mm	170mm	106g	61094013
19301214	12 x 14mm	170mm	102g	61094014
19301417	14 x 17mm	190mm	132g	61094017

FLARE NUT SPANNERS – IMPERIAL

- 6 point
- 12° ring offset
- Chrome vanadium alloy steel
- Chrome plated
- DIN 3118



Item Code	Size	Length	Weight	Bishops Code
59301012	5/16" x 3/8"	130mm	53g	61094510
59301214	3/8" x 7/16"	150mm	78g	61094520
59301618	1/2" x 9/16"	170mm	102g	61094530
59301820	9/16" x 5/8"	190mm	132g	61094540
59302224	11/16" x 3/4"	210mm	170g	61094550
59302428	3/4" x 7/8"	230mm	218g	61094560

FLAT RING SLOGGING SPANNERS – METRIC

- Powder coated matte black
- Hardness 34-40HRC for sizes 24–46mm
- Hardness 30-36HRC for sizes 50–90mm



Item Code	Size	Length	Weight	Bishops Code
10B0-27	27mm	180mm	247g	61095010
10B0-30	30mm	190mm	354g	61095015
10B0-32	32mm	190mm	404g	61095020
10B0-36	36mm	205mm	499g	61095030
10B0-41	41mm	230mm	658g	61095040
10B0-46	46mm	240mm	886g	61095046
10B0-50	50mm	253mm	1.125kg	61095050
10B0-55	55mm	265mm	1.33kg	61095055
10B0-60	60mm	280mm	1.245kg	61095060
10B0-65	65mm	298mm	1.875kg	61095065
10B0-70	70mm	330mm	2.965kg	61095070
10B0-75	75mm	330mm	2.735kg	61095075
10B0-80	80mm	345mm	3.675kg	61095080
10B0-85	85mm	345mm	3.71kg	61095085

FLAT RING SLOGGING SPANNERS – IMPERIAL

- Powder coated matte black
- Hardness 34-40HRC for sizes 24–46mm
- Hardness 30-36HRC for sizes 50–90mm



Length	ID	Bishops Code
230mm	1 1/2"	61095238
230mm	1 3/16"	61095240
225mm	1"	61095241
235mm	1 15/16"	61095246



ADJUSTABLE & PIPE WRENCHES

ADJUSTABLE WRENCHES

- Chrome plated steel



Item Code	Jaw Capacity	Length	Bishops Code
W072001	20mm	160mm (6")	63521142
W072002	25mm	200mm (8")	63521145
W072003	30mm	250mm (10")	63521148
W072004	35mm	300mm (12")	63521151
W072005	43mm	375mm (15")	63521155

ADJUSTABLE WRENCHES

- Chrome vanadium steel
- Polish, chrome plated
- Japanesque type
- DIN 3117



3611-10R



3611-18HR

Item Code	Jaw Capacity	Length	Weight	Bishops Code
3611-06R	20mm	150mm	125g	61080106
3611-08R	25mm	200mm	226g	61080108
3611-10R	30mm	250mm	430g	61080110
3611-12R	35mm	300mm	680g	61080112
3611-15HR	43mm	375mm	1.48kg	61080115
3611-18HR	52mm	450mm	1.75kg	61080118
3611-24HR	62mm	600mm	3.34kg	61080124

ADJUSTABLE WRENCHES

- Chrome vanadium steel
- Phosphate finish
- Japanesque type
- DIN 3117



3611-10P



3611-18HP

Item Code	Max. Opening	Length	Weight	Bishops Code
3611-06P	20mm	150mm	0.125kg	61080506
3611-08P	25mm	200mm	0.226kg	61080508
3611-10P	30mm	250mm	0.430kg	61080510
3611-12P	35mm	300mm	0.680kg	61080512
3611-15HP	43mm	375mm	1.485kg	61080515
3611-18HP	52mm	450mm	1.750kg	61080518

ALUMINIUM PIPE WRENCHES



- Lightweight cast aluminium alloy
- Replaceable jaws C-60
- Titalium finish for better protection
- UNE-16554 type A, GGG-W-651 E type II, Class C US fed specs



Item Code	Length	Minimum Bending Force	Weight	Bishops Code
61044	250mm	881Nm	0.5kg	64080710
61023	300mm	1,035Nm	0.78kg	64080712
61024	350mm	1,689Nm	0.95kg	64080714
61025	450mm	2,644Nm	1.64kg	64080718
61026	600mm	3,672Nm	2.57kg	64080724
61027	900mm	5,949Nm	4.96kg	64080736
61028	1,200mm	6,830Nm	7.49kg	64080748

ALUMINIUM PIPE WRENCHES



- Lightweight aluminium
- Professional strength
- Heavy duty
- Durable and easy to use



Item Code	Description	Length	Pipe Capacity	Weight	Bishops Code
31090	Model 810	250mm (10")	40mm (1½")	0.4kg (0.8lb)	64080813
47057	Model 812	300mm (12")	50mm (2")	1.1kg (2.4lb)	64080815
31095	Model 814	350mm (14")	50mm (2")	1.1kg (2.4lb)	64080814
31100	Model 818	450mm (18")	65mm (2½")	1.7kg (3.7lb)	64080818
31105	Model 824	600mm (24")	80mm (3")	2.7kg (5.9lb)	64080824
31110	Model 836	900mm (36")	125mm (5")	5kg (11lb)	64080836
31115	Model 848	1,200mm (48")	150mm (6")	8.4kg (18.5lb)	64080848

HEAVY DUTY PIPE WRENCHES



- Sturdy cast iron housing
- I-beam handle with forged hook jaw
- Self-cleaning threads
- Replaceable hook and heel jaws



Item Code	Description	Length	Pipe Capacity	Weight	Bishops Code
31005	Model 8	200mm (8")	25mm (1")	0.3kg (0.75lb)	64080804
31010	Model 10	250mm (10")	40mm (1½")	0.8kg (1.75lb)	64080805
31015	Model 12	300mm (12")	50mm (2")	1.2kg (2.75lb)	64080806
31020	Model 14	350mm (14")	50mm (2")	1.6kg (3.5lb)	64080807
31025	Model 18	450mm (18")	65mm (2½")	2.6kg (5.75lb)	64080808
31030	Model 24	600mm (24")	80mm (3")	4.4kg (9.75lb)	64080809
31035	Model 36	900mm (36")	125mm (5")	8.7kg (19lb)	64080810
31040	Model 48	1,200mm (48")	150mm (6")	15.6kg (34.25lb)	64080811
31045	Model 60	1,500mm (60")	200mm (8")	23.3kg (51.25lb)	64080812

PIPE WRENCHES

- Professional stillson type
- High quality steel



Item Code	Capacity	Length	Weight	Bishops Code
6531-10	32mm	250mm	0.60kg	64080607
6531-12	40mm	300mm	0.78kg	64080612
6531-14	48mm	355mm	1.05kg	64080614
6531-18	60mm	450mm	1.72kg	64080618
6531-24	75mm	600mm	3.15kg	64080624
6531-36	100mm	900mm	6.28kg	64080636
6531-48	140mm	1,200mm	9.75kg	64080648



CHAIN WRENCH

- Suitable for use on oil filters
- Capacity: 60–140mm
- Length: 225mm
- Weight: 359g



Item Code	Bishops Code
3204	62094220

CHAIN TONGS



Item Code	Pipe Capacity	Handle Length	Bishops Code
61037	6"	900mm	64085200
61038	8"	1,100mm	64085250
61138	12"	1,300mm	64085255
61139	16"	1,300mm	64085258

STRAP WRENCH

- Professional quality, lever handle with heavy duty strap
- Ideal for use on sanitary fittings, pipes, oil filters and more
- Capacity: 60–140mm
- Length: 223mm
- Weight: 242g



Item Code	Bishops Code
3203	62094120

CHAIN WRENCH

- Drop forged steel handle and jaw
- Special steel chain
- Ideal for use in confined spaces
- The double-jaw system provides a fast, ratchet-like action in both directions
- Powder coated red handle with a black chain
- 4" capacity
- Handle hardness: 30–45HRc
- Handle teeth hardness: 50–62HRc
- Weight: 820g



Item Code	Bishops Code
61035	64081350

DRUM PLUG WRENCH

- Convenient tool that opens almost all types of drums
- Made from hardened and tempered aluminium for extra strength
- Compact design for easy storage
- Designed to fit onto most 2" and 3/4" drum plugs



Item Code	Bishops Code
DRW/AL-01	68590010



THE USUAL SUSPECTS – A LINE-UP OF THE MOST COMMON PLIERS



1 Combination Pliers are suitable for all applications. Gripping, cutting, twisting and pulling – these pliers handle every job.

2 Linesman's Pliers are very similar to combination pliers but often have additional features such as wire crimpers to suit electricians. Insulated models are available.

3 Long Nose Pliers have a long, lean profile and are used for detailed or precision work and squeezing into tight spaces.

4 Safety Wire Twisting Pliers are used to create uniform twists in wire. Primarily used to secure electrical connections but can also quickly secure fasteners.

5 Circlip Pliers are used for fitting circlips to bores. They come in two designs, one for internal circlips and one for external.

6 Multi-Grip Pliers have a sliding bottom jaw that can be locked into any number of positions and are commonly used for turning and holding nuts, bolts and grabbing irregular objects.

7 Locking Pliers feature a powerful locking and tensioning mechanism to free up both hands. Available with a wide range of jaw styles for different tasks.

8 Insulated Pliers come in every style. These pliers have a dielectric coating that covers the handles, reducing their ability to conduct electricity. Insulated pliers should be used whenever you are working within close proximity to live electrical circuits or energised components. Look for our lightning bolt icon to help identify these tools.

Any pliers not conforming to the above have been named specialist pliers, with a description of their purpose in the product title.

Can't find the pliers you need? Ask Bishops!

4 PIECE EUROPEAN TYPE PLIERS SET KING TONY

• Weight: 1.17kg

Includes:

- 1 x Combination pliers – 163mm
- 1 x Line diagonal cutting nipper – 163mm
- 1 x Line long nose pliers – 200mm
- 1 x Groove joint pliers – 253mm



Item Code
42104GP

Bishops Code
61008940

4 PIECE EUROPEAN TYPE PLIERS SET KING TONY

Includes:

- 1 x Combination pliers – 205mm
- 1 x Heavy duty diagonal cutting pliers – 200mm
- 1 x Long nose pliers – 200mm
- 1 x Groove joint pliers – 253mm



Item Code
42124GP

Bishops Code
61057125

7 PIECE PLIERS SET

- Drop-forged polished steel
- Hardened cutting edges
- Comfort grip
- Includes:**
- 1 x Groove joint pliers – 200mm
- 2 x Slip joint pliers – 160 & 200mm
- 1 x Linesman pliers – 180mm
- 2 x Long nose pliers – 115 & 160mm
- 1 x Diagonal pliers – 160mm



Item Code	Bishops Code
W001306	63521078

4 PIECE 1,000V INSULATED PLIERS SET



- Polished head
- Chrome vanadium steel
- Insulated, dual density TPR handle offers superior protection grip and comfort
- Tray category #4, suitable for King Tony tool chests and trolleys
- Tray size: 375(l) x 265(w)mm
- Includes:**
- 1 x Combination pliers – 185mm
- 1 x Diagonal cutting pliers – 167mm
- 1 x Long nose pliers – 210mm
- 1 x Multi-grip box joint pliers – 250mm



Item Code	Bishops Code
40604GP	60507130

6 PIECE EUROPEAN TYPE CIRCLIP PLIERS SET



- Weight: 1.33kg
- Includes:**
- 2 x Angled circlip pliers – 170mm
- 2 x Straight circlip pliers – 180mm
- 2 x Straight circlip pliers – 250mm



Item Code	Bishops Code
42116GP	61008950

15 PIECE 10½" HEAVY DUTY CIRCLIP PLIERS SET



- Ideal for internal and external circlip removing and replacement
- Ratcheting locking action handles
- Weight: 1.3kg
- Includes:**
- 1 x Internal straight circlip pliers
- 1 x External straight circlip pliers
- 2 x 15° Internal interchangeable
- 2 x 45° Internal interchangeable
- 2 x 90° Internal interchangeable
- 2 x 15° External interchangeable
- 2 x 45° External interchangeable
- 2 x 90° External interchangeable
- 6 Piece screw (M5 x 0.8mm)



Item Code	Bishops Code
45115PP	61008955

MINIATURE PLIERS



- Polypropylene + thermoplastic rubber (TPR) grip handle
- Polished heads



6114-05

Item Code	Description	Wire Cutting Capacities			Length	Weight	Bishops Code
		Soft	Medium	Hard			
6114-05	Linesman	3mm	2mm	1.6mm	140mm	100g	61020215
6214-45	Diagonal	0.6mm	-	-	115mm	97g	61020230
6214-05	Diagonal	1.25mm	-	-	127mm	105g	61020235
6314-05	Long Nose	3mm	2mm	1.6mm	134mm	105g	61020245

EUROPEAN TYPE COMBINATION PLIERS



- European type
- Polished head
- PP + TPR grip handle
- DIN ISO 5746



Item Code	Wire Cutting Capacities				Length	Weight	Bishops Code
	Soft	Medium	Hard	Piano			
6111-06	4mm	2.8mm	1.8mm	1.6mm	163mm	200g	61010530
6111-07	4mm	3mm	2mm	1.6mm	188mm	260g	61010535
6111-08	4mm	3mm	2mm	1.6mm	213mm	340g	61010540

1,000V INSULATED COMBINATION PLIERS



- 1,000V rated for safety on the job
- VDE certified
- Unique, three-part insulation with white under-layer provides a warning sign that insulation may be compromised
- Multi-colour, sleek design with small thumb guards for ease of handling and easy storage on your tool belt
- Crimping die behind hinge for superior leverage when crimping non-insulated connectors, lugs and terminals, and toothed pipe-grip for greater power
- Length: 221mm



Item Code	Bishops Code
A-12098-EINS	61018725

GET MORE AT BISHOPS



CABLE TESTERS & MULTIMETERS

From Page 369



LINESMAN, LONG NOSE & FENCING PLIERS

HAND & CUTTING TOOLS

LINESMAN PLIERS

- Drop-forged carbon steel
- Bi-material comfort handle



Item Code	Length	Bishops Code
W031005	160mm (6")	63521063
W031006	200mm (8")	63521066

1,000V INSULATED LINESMAN COMBINATION PLIERS



- Chrome vanadium steel
- Polished head
- Insulated, dual density TPR handle offers superior protection grip and comfort
- Heavy duty
- IEC DIN EN 60900
- Length: 200mm
- Weight: 386g
- Wire Cutting Capabilities:**
 - Soft: 4.0mm
 - Medium: 3.0mm
 - Hard: 2.0mm
 - Piano: 1.6mm



Item Code	Bishops Code
6116-08A	61010545

LONG NOSE PLIERS

- Drop-forged carbon steel
- Bi-material comfort handle



Item Code	Length	Bishops Code
W031001	160mm (6")	63521055
W031002	200mm (8")	63521057

EUROPEAN TYPE LONG NOSE PLIERS



- DIN ISO 5745



Item Code	Wire Cutting Capacities				Length	Weight	Bishops Code
	Soft	Medium	Hard	Piano			
6311-06	4mm	2.8mm	1.8mm	1.6mm	163mm	152g	61018530
6311-08	4mm	3mm	2mm	1.6mm	200mm	227g	61018540

EUROPEAN TYPE BENT NOSE PLIERS



- Polypropylene (PP) + thermoplastic rubber (TPR) grip handle
- DIN ISO 5745



Item Code	Wire Cutting Capacities				Length	Weight	Bishops Code
	Soft	Medium	Hard	Piano			
6331-06	4mm	2.8mm	1.8mm	1.6mm	163mm	148g	61018630
6331-08	4mm	3mm	2mm	1.6mm	200mm	218g	61018640

1,000V INSULATED LONG NOSE PLIERS



- TPR grip handle
- Polished head
- Chrome vanadium steel
- IEC DIN EN 60900
- Length: 210mm
- Weight: 250g
- Cutting Capacities:**
 - Soft wire: 4mm
 - Medium hard wire: 3mm
 - Hard wire: 2mm
 - Piano wire: 1.6mm



Item Code	Bishops Code
6318-08A	61018680

EXTRA LONG NOSE PLIERS



- Slim jaws design for gripping components in recessed areas
- PVC handle grip
- Length: 280mm



Item Code	Bishops Code
6319-11C	60518056

PARROT BEAK FENCING PLIERS



- Multi-function pliers
 - Made from high quality chrome vanadium steel
 - Designed for heavy-duty use
 - Extra long handles for better leverage
 - Black anti-rust phosphate surfaces
 - Length: 280mm
- Features include:**
- Pliers for stretching and twisting wire
 - Wire cutters for cutting fence wire and components
 - Hammer face for striking nails
 - Staple holder and puller for simple staple insertion and removal
 - Crimping jaws for splicing wire



Item Code
7FP

SPECIAL ORDER: PLEASE QUOTE ITEM CODE UPON ORDERING THIS PRODUCT

EUROPEAN TYPE CIRCLIP PLIERS



- Internal and external
- Straight and angled pattern
- DIN 5254 and DIN 5256



Item Code	Description	Tip	Capacity	Length	Weight	Bishops Code
68HS-07	Straight – Internal	1.8mm	19–60mm	180mm	130g	61008020
68SS-07	Straight – External	1.8mm	19–60mm	180mm	130g	61008320
68HS-10	Straight – Internal	2.3mm	40–100mm	250mm	291g	61008720
68SS-10	Straight – External	2.3mm	40–100mm	250mm	291g	61008820
68HB-07	Angled – Internal	1.8mm	19–60mm	180mm	130g	61008040
68SB-07	Angled – External	1.8mm	19–60mm	180mm	130g	61008340
68HB-10	Angled – Internal	2.3mm	40–100mm	250mm	291g	61008740
68SB-10	Angled – External	2.3mm	40–100mm	250mm	291g	61008840

GROOVE JOINT PLIERS

- Pipe wrench style gripping pliers
- Undercut tongue and grooves
- Adjustable nut and joint fastener
- Bi-material comfort handle
- Length: 250mm (10")



Item Code	Bishops Code
W031014	63521075

GROOVE JOINT MULTI-GRIP PLIERS



- Seven opening positions
- PVC handle grip
- DIN ISO 8976



Item Code	Jaw Capacity	Length	Weight	Bishops Code
6511-10C	50mm	250mm	400g	61022450
6511-13C	65mm	325mm	808g	61022460
6511-17C	100mm	425mm	1.15kg	61022470

GROOVE JOINT MULTI-GRIP PLIERS



- Seven opening positions
- Dual density TPR handle offers superior grip and comfort
- German style line groove joint pliers
- Length: 253mm
- DIN ISO 8976



Item Code	Bishops Code
6516-10	61022455

GROOVE JOINT MULTI-GRIP PLIERS



- Chrome vanadium steel
- User-friendly handle position
- Excellent for gripping, pressing and bonding purposes
- Quick lock
- PVC grip handle
- DIN ISO 8976
- Length: 250mm



Item Code	Bishops Code
6517-10C	61022485

1,000V INSULATED GROOVE JOINT MULTI-GRIP PLIERS



- Insulated, dual density TPR handle offers superior protection grip and comfort
- Polished head
- Chrome vanadium steel
- Length: 250mm
- IEC DIN EN 60900



Item Code	Bishops Code
6516-10A	61022480

CURVED JAW LOCKING PLIERS

- Chrome-vanadium steel
- Easy locking and release
- Adjustable tension screw
- Bi-material comfort handle grip
- Length: 250mm (10")



Item Code	Bishops Code
W031095	63521081

LOCKING PLIERS



- Chrome vanadium alloy steel
- Chrome plated (R) or nickel plated (N)
- Adjusting screw and release lever
- ASME B107.24

6031-10N



Item Code	Description	Jaw Capacity	Length	Weight	Bishops Code
6011-07R	Curved Jaw	38mm	180mm	367g	61016135
6011-10R	Curved Jaw	48mm	250mm	542g	61016150
6031-07N	Straight Jaw	33mm	180mm	392g	61016750
6031-10N	Straight Jaw	45mm	250mm	573g	61016730



LOCKING PLIERS & CLAMPS

HAND & CUTTING TOOLS

MINIATURE LONG NOSE LOCKING PLIERS



- With adjusting screw and release lever
- Jaw capacity: 51mm
- Overall length: 165mm
- Weight: 205g



Item Code	Bishops Code
6315-06	61020250

CHAIN GRIP LOCKING PLIERS



- Chain can hold around any shape or size
- Convenient for awkwardly shaped pieces
- Adjusting screw and release lever
- Capacity: 60-140mm
- Overall length: 225mm
- Weight: 733g



Item Code	Bishops Code
6655-09	61016775

SHEET METAL GRIP LOCKING PLIERS



- Chrome molybdenum alloy steel
- Nickel plated
- Adjusting screw and release lever
- Makes bending, forming, and crimping sheet metal easier
- Jaw capacity: 13mm
- Overall length: 206mm
- Weight: 455g



Item Code	Bishops Code
6605-08	61016770

C-CLAMP LOCKING GRIP PLIERS



6615-11

Item Code	Jaw Capacity	Length	Weight	Bishops Code
6615-11	100mm	280mm	790g	61016810
6625-11	96mm	280mm	840g	61016820
6625-18	200mm	457mm	1.22kg	61016825

WELDING CLAMP LOCKING PLIERS



- U-shaped jaws allow enhanced visibility and more working space
- Holds work in proper alignment
- For use in welding or holding awkward shapes in place
- Jaw capacity: 43mm
- Overall length: 230mm
- Weight: 625g



Item Code	Bishops Code
6665-09	61016890

UNIVERSAL BAR CLAMP

- General purpose clamp
- Simple to use
- Easy clamp and release functions
- Capacity: 305mm



Item Code	Bishops Code
W032033	63521084

G CLAMP – SUPER GRADE

- Corrosion resistant handle and broad swivel pad
- Cast heavy ribbed frame for strength and durability
- Corrosion resistant zinc plated sliding bar handle, swivel pad and Whitworth threaded screw



Item Code	Jaw Opening	Throat Depth	Frame Proof Load	Bishops Code
61152	75mm	44mm	455kg	61502015
61153	100mm	59mm	545kg	61502040
61155	150mm	75mm	635kg	61502060
61156	200mm	80mm	775kg	61502080
61157	250mm	90mm	1,000kg	61502100
61158	300mm	100mm	1,135kg	61502120

QUICK ACTION CLAMPS – COMPOSITE HANDLE



- Serrations on 6 edges for maximum slip resistance
- Heavy ribbed malleable cast iron jaws
- Protective caps
- ACME thread
- Corrosion resistant zinc plated screw and bar
- Swivel pad for uneven surfaces
- Large plastic handle ergonomically designed for maximum comfort and increased clamping force
- Clamping pressure to 5,000N
- Also available in 300, 500, 800, 1,000, 1,250, 1,500 and 2,000mm versions



Item Code	Opening Width	Depth	Bar	Weight	Bishops Code
61173	150mm	80mm	25 x 6mm	800g	61502360
61174	200mm	80mm	25 x 6mm	900g	61502380
61175	250mm	120mm	30 x 8mm	1.5kg	61502400
61177	400mm	120mm	30 x 8mm	1.8kg	61502460
61179	600mm	120mm	30 x 8mm	2.2kg	61502500



TYPES OF CLAMPS

Spring Clamps, also called pinch clamps, are essentially a large clothes pin. Like a clothes pin, this clamp is simply two handles joined together by a steel spring. Spring clamps are simple, yet powerful tools for everyday jobs.



C-Clamps, also called locking clamps, apply a point of force in a similar way to the spring clamps. The opening width is generally adjusted by turning a knurled screw. Once at the desired position, the handles are squeezed together to lock into position.



G-Clamps are comprised of a semicircular steel frame with a heavy-gauge threaded spindle that is wound through one end, creating a "G"- shape when opened. The spindle turns to increase and decrease the opening.



F-Clamps form the shape of an "F", consisting of two horizontal bars joined together by a vertical bar. It has a wide opening capacity making it ideal for woodworking applications.

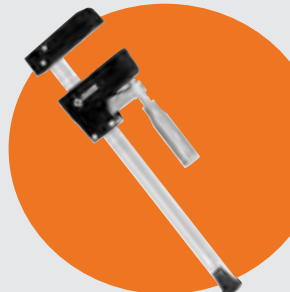

T-Bar Clamps consist of a long bar with adjustable jaws suitable for woodworking applications. The "T" shape comes from the spindle, which controls the jaw opening.

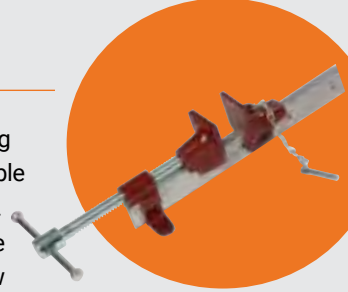

Magnetic Clamps are designed to accurately hold ferrous metals for welding and assembly. This clamp uses magnets to keep metals in place. Clamps come in different configurations to hold metals at different angles.

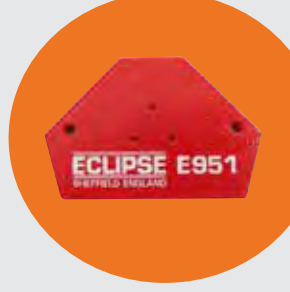

QUICK ACTION WOODWORKING CLAMPS

- Convenient, strong and accurate
- Quick adjustment mechanism by simply lifting the aluminium die-cast handle, the sliding jaw can be moved anywhere on the rail
- Rail is made from special "K" section steel profiled to minimize flexing and bending
- Serrations on the steel rail eliminate slippage
- Four hardened rollers in the moving head maintain a constant 90° angle under load, ensuring that the clamp heads remain parallel to each other and at right angles to the rail at all times
- Clamp jaws are encased in non-marring, glue resistant polypropylene casing



Item Code	Clamping Capacity	Bishops Code
KBC/12	300mm	61502420
KBC/40	1,000mm	61502510

T-BAR CRAMPS

- Primarily designed for the cramping of large section work pieces for joint gluing and general applications
- Jaws and nuts are made from ductile iron and the Acme threaded screw
- Handle are high quality corrosion resistant steel
- T-bar sections are specially heat-treated Aluminium for strength and will resist twisting and distortion
- Fixed jaw comes with drilled feet for fixing to a work bench
- Heavy section clamp is more robust and is suitable for heavy-duty work
- 25 year warranty



LIGHT DUTY			HEAVY DUTY		
Item Code	Length	Weight	Item Code	Length	Weight
61213	750mm	2.6kg	61230	750mm	5kg
61214	1,000mm	2.8kg	61231	1,000mm	5.5kg
61215	1,250mm	3kg	61232	1,250mm	6kg
61216	1,500mm	3.2kg	61233	1,500mm	6.5kg
61217	1,750mm	3.4kg	61234	1,750mm	7kg
61218	2,000mm	3.6kg	61235	2,000mm	7.5kg
61220	2,500mm	4kg	61237	2,500mm	8.5kg
61221	3,000mm	4.4kg	61238	3,000mm	9kg
61222	3,500mm	4.8kg	61239	3,500mm	9.5kg

SPECIAL ORDER: PLEASE QUOTE ITEM CODE UPON ORDERING THIS PRODUCT

GET MORE AT BISHOPS



ENGINEERS VICES

Page 335



THE USUAL SUSPECTS – LINE-UP OF THE MOST COMMON CUTTERS

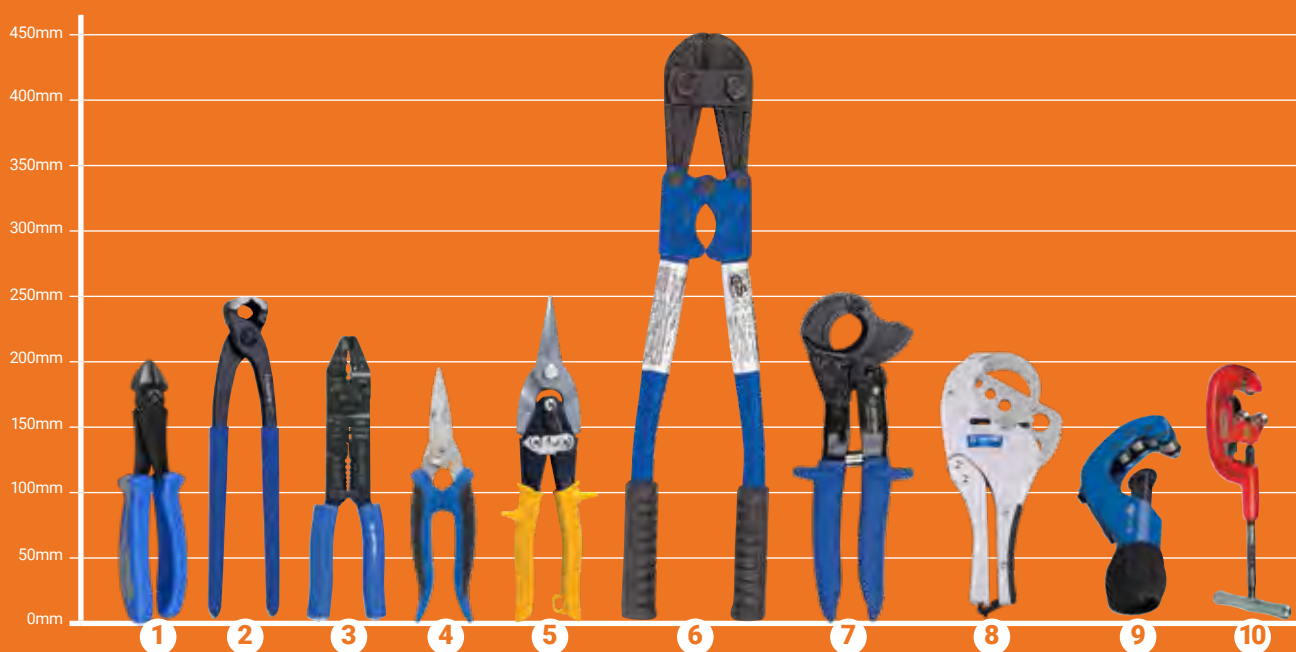

1 Diagonal Cutting Pliers

Without any gripping jaws, they apply their cutting jaws to powerfully snip through a range of wire diameters.

Suitable for: cutting soft/medium/hard wire, piano wire, nails and screws.

2 End Cutting Pliers

Designed to leave a close finish. Wide throat clearance allows an almost flush cut of nail and rivet heads.

Suitable for: cutting soft/medium/hard wire, piano wire, nails and screws.

3 Wire Cutting, Crimping & Stripping Pliers

Multi-purpose tools often used in the electrical industry. Cut, strip and crimp cables with one tool.

Suitable for: cutting soft/medium/hard wire, cables and small gauge bolts/screws

4 Scissors

Will always be one of the most useful cutting tools to own. Snip away at a variety of materials with a pair of industrial scissors.

Suitable for: cutting plastics, fabrics, rope, cardboard and assorted thin soft metals.

5 Tin Snips

Also known as aviation shears, have colour coded handles that designate the direction they are designed to cut best in. Left is red, right is green and straight cuts are yellow.

Suitable for: cutting sheet metal including tin, aluminium and thin steel.

6 Bolt Cutters

Designed to utilise incredible leverage into a focused cutting point. Their compounding action creates a powerful cutting force.

Suitable for: cutting bolts, screws, nails, shackles and wire.

7 Cable Cutters

Commonly used for softer metals. Ratcheting models will provide high torque and cutting power with low effort.

Suitable for: cutting copper, aluminium and other soft cables.

8 Hose Cutters

Typically used on pipes and hoses. A simple and effective tool that does the job.

Suitable for: cutting PVC, plastic, nylon and rubber hose and tube.

9 Tube Cutters

Fasten around the tube and rotate to make short work of soft metals and thin wall steel tubing. Various sizes are available to suit different diameters and materials.

Suitable for: cutting copper, brass, aluminium and thin wall steel tube.

10 Pipe Cutters

Heavy duty version of tube cutters. Replacement cutters for pipe and tube are available separately.

Suitable for: cutting steel, cast iron and clay pipes.

**Can't find the cutters you need?
Ask Bishops!**

bishopbros.com.pg sales@bishopbros.com.pg

DIAGONAL CUTTING PLIERS

- Drop-forged carbon steel
- Bi-material comfort handle
- Heavy duty gripping jaws
- Length: 180mm (7")



Item Code	Bishops Code
W031004	63521060

END CUTTING PLIERS

- Drop-forged carbon steel
- Bi-material comfort handle
- Heavy duty gripping jaws
- Suitable for cutting wires and cables
- Length: 160mm (6")



Item Code	Bishops Code
W031010	63521069

HEAVY DUTY EUROPEAN TYPE DIAGONAL CUTTING NIPPERS



- Polypropylene (PP) + thermoplastic rubber (TPR) grip handle
- Polished heads
- DIN 5749



Item Code	Wire Cutting Capacities				Length	Weight	Bishops Code
	Soft	Medium	Hard	Piano			
6211-06	4mm	2.8mm	2mm	1.6mm	163mm	180g	61012525
6231-07	4mm	3mm	2.2mm	2mm	188mm	220g	61012530
6231-08	5mm	3.5mm	2.2mm	2mm	200mm	280g	61012535

EUROPEAN TYPE END CUTTING PLIERS



- Polypropylene and thermoplastic rubber (TPR) grip handle
- DIN ISO 5748
- Length: 164mm
- Weight: 273g
- Cutting Capacities:
 - Soft wire: 4mm
 - Medium hard wire: 3mm
 - Hard wire: 1.6mm
 - Piano wire: 1.6mm



Item Code	Bishops Code
6411-06	61020260

1,000V INSULATED HEAVY DUTY DIAGONAL CUTTING PLIERS



- TPR grip handle
- Polished head
- Chrome vanadium steel
- IEC DIN EN 60900
- Length: 190mm
- Weight: 280g
- Cutting Capacities:
 - Soft wire: 5mm
 - Medium hard wire: 3.5mm
 - Hard wire: 2.2mm
 - Piano wire: 2mm



Item Code	Bishops Code
6236-07A	61010610

EUROPEAN TYPE LINE END CUTTING PLIERS



- PVC grip handle
- DIN ISO 9242
- Weight: 445g
- Length: 254mm
- Cutting Capacities:
 - Soft wire: 3mm
 - Medium hard wire: 2mm
 - Hard wire: 1.6mm



Item Code	Bishops Code
6431-10C	61014840

GET MORE AT BISHOPS ▶

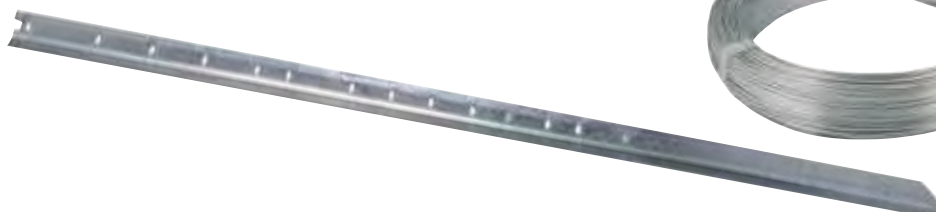

STAR PICKETS & TIE WIRE

Page 364



WIRE CRIMPING & STRIPPING PLIERS & INDUSTRIAL SCISSORS

HAND & CUTTING TOOLS

WIRE CUTTING & CRIMPING PLIERS



- Wire cutter, stripper and bolt cutter and crimper in one tool
- Wire cutting capacity: 6mm
- Bolt cutting capacity: 2.6–5mm
- Open barrel terminal crimping capacity: 1.5–6mm
- Wire stripping capacity: 0.75–6mm



6732-09

Item Code	Insulated Terminal Crimping Capacity	Bishops Code
6732-09	1.5–6mm	64540040
6721-10	0.5–6mm	64540240

WIRE STRIPPING PLIERS



- Cuts and strips wires
- Wire cutter diameter: 6mm²
- Wire stripper: 0.5–5.5mm²
- Length: 155mm
- Weight: 103g



Item Code	Bishops Code
6741-06	64545025

WIRE STRIPPING PLIERS

- Drop-forged carbon steel
- Bi-material comfort handle
- Length: 160mm (6")



Item Code	Bishops Code
W031011	63521072

WIRE STRIPPING PLIERS



- With spring and adjusting screw
- Wire cutter diameter: 5mm
- Wire stripper: 10mm²
- Overall length: 155mm



Item Code	Bishops Code
6711-06	64545050

1,000V INSULATED WIRE STRIPPING PLIERS



- Thermoplastic rubber (TPR) grip handle
- Polished head
- With spring and adjusting screw
- Chrome vanadium steel
- Wire cutter diameter: 5mm
- Wire stripper: 10mm²
- Overall length: 160mm
- IEC DIN EN 60900



Item Code	Bishops Code
6716-06A	64545100

SCISSORS



- Ambidextrous comfort grip handles
- One knife edge blade and one serrated edge blade
- Stainless steel blades
- Ideal for all industrial, food processing and stationery applications
- Length: 230mm



Item Code	Bishops Code
29-900	62547515

SCISSORS

- Ergonomic bi-material comfort grip handle
- Durable stainless steel blades
- Right handed
- Ideal for thick cardboard, aluminium, rubber, leather and more
- Blade length: 200mm



Item Code	Bishops Code
SCMT28562	62547512

5" ELECTRICIAN SCISSORS



- Stainless steel blades
- PP and TPR handle material
- Cutting Length: 55mm
- Overall Length: 145mm



Item Code	Bishops Code
6ABT2-55	62547545

AVIATION TIN SNIPS

- Hardened carbon steel jaws
- Serrated cutting edges
- Induction hardened cutting edges to 60-62 HRC
- Cutting capacity: 18G (cold rolled steel) & 22G (stainless steel)
- Length: 250mm (10")



Item Code	Description	Bishops Code
W015006	Right Hand	63521003
W015007	Left Hand	63521006
W015008	Straight	63521009
W000401	3 Piece Set – Includes Right, Left & Straight Snips	63521012

AVIATION TIN SNIPS



- Drop forged chrome molybdenum alloy steel
- Blades with serrated edges
- Special labour-saving design perfect for professional users
- Induction hardened cutting edges 59-62 HRC
- High tensile and torsional strength for longer life
- Solid and comfortable handle with non-slip design
- Hang-up hole provided for convenient storage
- Safety auto latch (D.PAT.)
- Overall length: 250mm

Cutting Capacities:

- Copper: 1.5mm
- Cold-rolled steel: 1.2mm
- Hard steel HRC30: 0.8mm
- 304 Stainless steel: 0.7mm



61070040

Item Code	Description	Colour	Length	Weight	Bishops Code
74010	Left Cut	Red	248mm	375g	61070020
74020	Right Cut	Green	248mm	375g	61070040
74030	Straight Cut	Yellow	250mm	380g	61070060

OFFSET TIN SNIPS



- Offset blades keep hands away from metal
- Unique design for professional users
- Drop forged chrome molybdenum alloy steel blades with serrated edges
- Induction hardened cutting edges 59-62 HRC

Cutting Capacities:

- Copper: 1.8mm
- Cold-rolled steel: 1.5mm
- Hard steel HRC30: 1.0mm
- 304 Stainless steel: 0.9mm



Item Code	Description	Colour	Length	Weight	Bishops Code
74250	Left Cut	Red	250mm	400g	61070080
74260	Right Cut	Blue	250mm	400g	61070090

STRAIGHT TIN SNIPS



- American type
- One piece forged construction
- Cushion handle with smooth bows for ease in use and safety
- Designed for cutting straight and wide curves to the left or right
- Drop forged of high carbon steel
- Induction hardened cutting edges 58-61 HRC
- Suitable for gaskets



Item Code	Cutting Capacities		Length	Weight	Bishops Code
	Rolled Steel	Stainless Steel			
74410	0.78mm	0.45mm	254mm	480g	61070540
74414	1.2mm	0.70mm	356mm	780g	61070550

OFFSET TIN SNIPS



- British type
- One piece forged construction
- Comfortable vinyl coated handles
- Drop forged of high carbon steel
- Induction hardened cutting edges 58-61 HRC



Item Code	Cutting Capacities		Length	Weight	Bishops Code
	Rolled Steel	Stainless Steel			
74512	0.91mm	0.63mm	305mm	670g	61070160
74514	1.20mm	0.70mm	356mm	920g	61070170

COMPACT BOLT CUTTERS



- High leverage
- Compact, lightweight design with dual density TPR handles
- Cutting capacity: 5mm
- Length: 200mm
- Weight: 400g



Item Code	Bishops Code
6133-08	63522115

BOLT CUTTERS



- Chrome vanadium alloy steel



6131-18

Item Code	Capacity	Length	Weight	Bishops Code
6131-12	5mm	300mm	0.76kg	63522120
6131-14	7mm	350mm	1.0kg	63522130
6131-18	8mm	450mm	1.51kg	63522140
6131-24	10mm	600mm	2.35kg	63522160
6131-30	13mm	750mm	3.75kg	63522170
6131-36	16mm	900mm	5.50kg	63522180
6131-42	18mm	1,050mm	8.56kg	63522190



CABLE, WIRE ROPE & TUBE CUTTERS

HAND & CUTTING TOOLS

CABLE CUTTER

- K683/T Blade
- Cutting capacity: 12mm
- Length: 220mm



Item Code	Bishops Code
62151	86440045

1,000V INSULATED CABLE CUTTER

- Insulated handles to 1,000V
- Cutting capacity: 6.7mm
- Length: 150mm
- Weight: 180g



Item Code	Bishops Code
76147	61020505

1,000V INSULATED CABLE CUTTER

- 1,000V rated for safety on the job, VDE certified
- Unique, three-part insulation with white under-layer provides a warning sign that insulation may be compromised
- Multi-colour, sleek design with small thumb guards for ease of handling and storage is perfect for working in confined spaces
- Precision, one-handed shearing action

Cutting capacities:

- Aluminium (not ACSR): 4/0
- Soft copper: 2/0
- Communication cable: 100-pair 24 AWG



Item Code	Bishops Code
A-63050-EINS	61020515

1,000V INSULATED ELECTRICIANS RATCHET CABLE CUTTER

- Handles insulated to 1,000V
- Cutting capacity: 32mm
- Length: 260mm
- Weight: 600g



Item Code	Bishops Code
73010	61020510

1,000V INSULATED RATCHET CABLE CUTTER

- Cutting capacity: 70mm
- Length: 600mm



Item Code	Bishops Code
73009	61020512

HEAVY DUTY WIRE ROPE CUTTER

- Cutting capacity: 14–10mm
- Length: 600mm
- Weight: 2.4kg



Item Code	Bishops Code
625172	63525010

2-IN-1 RATCHET TUBE CUTTER

- Easy one-hand operation
- Cut into thick pipe and thin pipe
- Easily apply for 50, 63mm O.D.
- Comfortable TPR handle
- For PE, PP, PVDF, PB, PVC or similar tube
- Advanced tool steel blade and aluminium body
- Adjusting tab on the back
- Cutting capacity: 6–63mm



Item Code	Bishops Code
7913A-63	64020008

MINI TUBE CUTTER

- For copper, brass and aluminium tube
- Quick adjustment and easy to change the cutting wheel
- Ergonomic handle design for comfortable operation
- Full-stop feed system prevents wheels and rollers from coming into contact
- Max. tube thickness: 1.2mm
- Capacity: 3–19mm
- Length: 62mm



Item Code	Bishops Code
7915A-19	64020011

TUBE CUTTER



- For copper, brass and aluminium tubes
- Quick adjustment and easy to change the cutting wheel
- Ergonomic handle design for comfortable operation
- Full-stop feed system prevents wheels and rollers from coming into contact
- Max. tube thickness: 1.2mm
- Capacity: 3–45mm
- Length: 140mm



Item Code	Bishops Code
7914B-45	64020012

UNIQUE TUBE CUTTER



- For cutting copper tubing
- Special steel cutting wheel and reamer with a zinc alloy body
- Hardness: 55–60HRC
- Red powder coating
- Pipe capacity: 6–42mm
- Weight: 550g



Item Code	Description	Bishops Code
63119	Unique Tube Cutter	64020530
63111	Tube Cutter Wheel for Cutting 42mm Copper	64020532
63114	Tube Cutter Wheel for Cutting 2mm Stainless Steel	64020534

STAINLESS STEEL TUBE CUTTER



- Designed for optimal performance on stainless steel
- The contoured frame allows for easy alignment
- Specially designed cutter wheel decreases drag for a smoother cut
- Pipe capacity: 3/16"–1 1/8"
- Weight: 0.68kg (1.5lb)



Item Code	Bishops Code
97212	64020520

RATCHET TUBING CUTTER



- Provided with foldable reamer
- Cuts without having to rotate tool completely around tubing
- Ratchet mechanism allows for tight area operation
- Cuts through some of the toughest surfaces, including stainless steel, wall conduit, copper and aluminium
- One hand operation
- Limited risks of hand fatigue and injuries
- Jaw capacity: 3–28mm
- Max cutting thickness: Stainless steel – 2mm, other materials – 3mm
- Comes with spare blade
- Weight: 389g



Item Code	Bishops Code
7912-21	64020010

PIRAINA® PIPE CUTTER



- Precision machined blades for quick and smooth cuts
- Has an ergonomic design and non-slip handles
- Fitted with a safety lock to reduce the risk of accidents
- Blades are interchangeable
- Cuts a wide variety of pipes including kevlar and PVC types
- Max. pipe capacity: 42mm
- Weight: 550g



Item Code	Description	Bishops Code
63205	Piraina® Pipe Cutter	64020005
64045	Cutter Blade to Suit	64020536

PIPE CUTTER

- Red powder coated finish
- Provides a fast, clean and convenient method of pipe cutting
- Capacity: 50mm



Item Code	Bishops Code
	64020040

PIPE CUTTERS



- Capacity: 50–100mm
- Weight: 8kg



Item Code	Description	Bishops Code
63175	Steel Pipe Cutter	64020550
63185	Steel Cutter Wheel for Steel Cutting	64020585
63186	Steel Cutter Wheel for Stainless Steel Cutting	64020586

HEAVY DUTY PIPE CUTTERS



- Fast, clean pipe cutting
- Second handle makes two-man leverage possible on large pipe sizes
- Extra-long shank protects adjustment threads, while an extra-large handle is provided for quick, easy adjustment



Item Code	Description	Capacity	Weight	Bishops Code
32840	No. 4-S	50–100mm (2–4")	8.2kg (18lb)	64020560
32850	No. 6-S	100–150mm (4–6")	10kg (22lb)	64020580



ROD CUTTER & BENDER, FLARING TOOLS & SEPARATOR PULLERS

HAND & CUTTING TOOLS

ROD CUTTER & BENDER

- Unique 2-in-1 combination tool, designed for cutting and bending of concrete reinforcing rods up to 180°
- Drop forged, heat treated jaws made from high grade alloy steel
- Shear cut blades cut and bend 60 rebar to 90° or 180°
- Can be bolted to floor or board for easy one-hand operation
- Made in Japan
- Capacity: 16mm
- Length: 1,320mm
- Weight: 16kg



Item Code	Description	Bishops Code
HITRC16B	Cutter & Bender	63526200
HITRCC16BL	Spare Blade Set	63526205

9 PIECE FLARING TOOL SET

- A handy kit suitable for flaring metal tubing in seven sizes
- Double flare
- Sizes: 3/16" - 3/8"

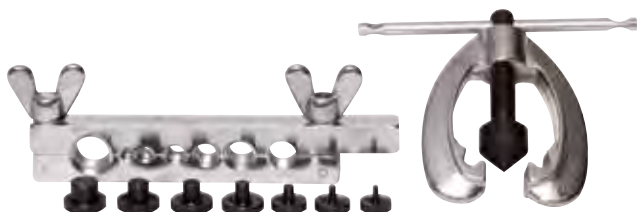

Item Code	Description	Bishops Code
		64050240

FLARING TOOL WITH RATCHET

- Eccentric cone flaring tool
- 6, 8, 10, 12, 14, 15, 16mm and 1/4", 5/16", 3/8", 1/2", 5/8", 3/4"
- Weight: 2.1kg



Item Code	Description	Bishops Code
57618		64050260

PRECISION RATCHETING FLARE TOOL

- Versatile and easy to use flaring tool
- Flares steel, stainless steel, hard copper and brass tubing up to wall thickness of .035"
- Ratcheting handle reduces effort required, especially in confined areas
- Quick to set-up, improving productivity
- Durable, eccentric mounting hardened steel flaring cone
- Handle clutch releases when flare is complete to iron and smooth flare
- Produces 45° flare in sizes from 1/8" - 3/4"
- Weight: 1.6kg (4lb)



Item Code	Description	Bishops Code
83037		64050250

GEAR PULLERS

- Chrome vanadium alloy steel
- Chrome plated and phosphate sunk finishing

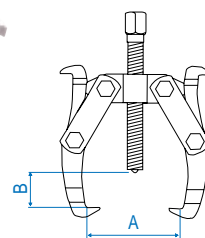

Item Code	Description	A	B	Weight	Bishops Code
7962-03	Two Jaw	75mm	60mm	440g	63032120
7962-04	Two Jaw	100mm	95mm	780g	63032220
7962-06	Two Jaw	150mm	150mm	1.65kg	63032320
7962-08	Two Jaw	200mm	235mm	3.5kg	63032420
7962-12	Two Jaw	300mm	280mm	7kg	63032620
7963-03	Three Jaw	75mm	60mm	550g	63032130
7963-04	Three Jaw	100mm	95mm	1.06kg	63032230
7963-06	Three Jaw	150mm	150mm	2.25kg	63032330
7963-08	Three Jaw	200mm	235mm	4.5kg	63032430
7963-12	Three Jaw	300mm	280mm	11kg	63032630

8 PIECE PRESSURE SCREW BEARING SEPARATOR PULLER SET

- Capacity: 75-105mm
 - Weight: 8.95kg
- Includes:
- 1 x 3/8" Bolt x 18t 415 hardened 42°-45°
 - 2 x Carbon steel main rods - 8" x 1.75P
 - 2 x Carbon steel extension rods - 8" x 1.75P
 - 1 x Carbon steel beam
 - 1 x Central bolt - 18.65(dia.)mm x 11.5(l)" x 10t
 - 1 x Carbon steel nut



Item Code	Description	Bishops Code
9BA22		63036360

12 PIECE BEARING SEPARATOR ASSEMBLY SET

- Weight: 5.4kg
- Includes:
- 2 x Set bearing separator & bolts, capacities: 30-50mm & 50-75mm
 - 1 x 3/8" Bolt x 120(l)mm x 24t 415 hardened 42°-45°
 - 1 x 1/2" Bolt x 135(l)mm x 20t 415 hardened 42°-45°
 - 4 x Main rods - hex bar 17mm 3/8" x 127(l)mm x 16t
 - 4 x Extension rods - hex bar 14mm 3/8" x 102(l)mm x 16t
 - 1 x Carbon steel beam
 - 1 x Carbon steel central bolt - 9/16" x 175(l) x 10t/inch



Item Code	Description	Bishops Code
9BA21		63036370

4 PIECE ROLLER STUD EXTRACTOR SOCKET SET



- Weight: 1.10kg
- Includes:
 - 4 x roller stud extractor sockets – M6, M8, M10 and M12



Item Code	Bishops Code
9TD014MR	48690560

5 PIECE VALVE SPRING COMPRESSOR SET



- Suitable for use on large engines and diesel engines
- Unique direct action compressor lever gives improved visibility and ease of use in areas of difficult access
- Dual size in 25 and 30mm adaptor
- Capacity: 35–140mm
- 280(w) x 390(l)mm
- Weight: 4.56kg



Item Code	Bishops Code
9AH025	62092280

PISTON RING COMPRESSORS



- The square adjustment key wrench forces the rings into the grooves, and clutch controls prevent them from expanding



Item Code	Height	Dia.	Weight	Bishops Code
9AC125-40	100mm	57–125mm	280g	62060140
9AC175-66	165mm	90–175mm	530g	62060160

DROP FORGED COIL SPRING COMPRESSORS



- Drop forged SCM435 jaws and leaded screws
- Both 21mm 6 point sockets and ½" wrench are available
- Suitable design for use in limited space under wheel arch



Item Code	Length	Weight	Bishops Code
9BF21	270mm	3.36kg	62064270
9BF11	370mm	3.51kg	62064370

GET MORE AT BISHOPS



TYRE REPAIR KIT

Page 385

WHEEL BALANCER

Page 389





CROWBARS & PRY BARS

HAND & CUTTING TOOLS

CROWBARS

- Used for digging holes and breaking clay, rock and concrete
- Forged from tough high tensile carbon manganese steel
- Ground and sharpened diamond point end for easier digging and breaking
- Heat treated for better performance and strength
- Anti-corrosive primer with enamel finish
- Long tapered blade



Item Code	Shape	Size	Bishops Code
5CB165025	Hexagon	1,650(l) x 25(w)mm	63510560
5CB180025	Hexagon	1,800(l) x 25(w)mm	63510580
5CBR180030	Round	1,800(l) x 30(w)mm	63510600

FENCE BAR

- Used for digging holes and breaking clay, rock and concrete
- Forged from tough high tensile carbon manganese steel
- Long tapered blade for easier digging
- Blade heat treated along the full length for better performance and strength
- Knob is forged on bar, not welded, and is optimum size for tamping
- Anti-corrosive primer with enamel finish
- Hexagon bar profile
- 1,800(l) x 30(w)mm



Item Code	Bishops Code
5FB180030	63512580

DUAL END PINCH BARS

- Used for levering and moving objects into place with a lift and swivel motion
- Forged from high tensile carbon manganese steel for maximum strength
- Heel offset to 40° for optimum lifting
- Hexagon bar profile for greater control
- Heat treated blade ends for better performance and strength



Item Code	Size	Bishops Code
5PB45016	450(l) x 16(w)mm	63514510
5PB60020	600(l) x 20(w)mm	63514520
5PB75025	750(l) x 25(w)mm	63514530
5PB90025	900(l) x 25(w)mm	63514540
5PB150025	1,500(l) x 25(w)mm	63514560
5PB150030	1,500(l) x 30(w)mm	63514580
5PB180025	1,800(l) x 25(w)mm	63514590

SPOON BARS

- Used for levering, prying between surfaces and aligning holes
- Forged from resilient 4140 grade (axle) steel
- Thin finely ground blade end for ease of entry between surfaces
- Forged, not turned, long tapered point ideal for aligning
- Full length heat treatment of shaft for best performance



Item Code	Size	Bishops Code
5SB45016	450(l) x 16(w)mm	63516580
5SB60020	600(l) x 20(w)mm	63516585
5SB75022	750(l) x 22(w)mm	63516590

ALIGNING PRY BAR

- Used for levering, prying between surfaces and aligning holes
- Forged from chrome alloy steel
- Thin finely ground blade end for ease of entry between surfaces
- 35-40 HRC



Item Code	Bishops Code
CAT/24	63518540

HEAVY DUTY ALIGNING PRY BARS

- Ideal for accurate positioning work
- Line up end for aligning and adjusting metals or woods
- Angled chisel end gives greater leverage when prying
- Manufactured from the highest quality alloy and carbon steel
- Fully heat treated shank for maximum strength and durability
- Corrosive resistant black oxide finish



Item Code	Body Dia.	Length	Weight	Bishops Code
40000	13mm	355mm	325g	63518610
40001	16mm	405mm	550g	63518620
40002	19mm	508mm	1kg	63518630
75004	22mm	760mm	2.3kg	63518640

3 PIECE DOMINATOR HEAVY DUTY PRY BAR SET

- All new steel capped end with composite ergonomically designed handle allows the user to strike the pry bar with a hammer without damaging the head
 - Made from the highest quality alloy and carbon steel, hardened and tempered the full length of the bar
 - Corrosion resistant finish
 - Curved blade for extra leverage
- Includes:**
- 305, 432 & 635mm long bars



Item Code	Bishops Code
61355	63518515

4 PIECE PRY BAR SET

- Weight: 3.2kg
- Includes:**
- 4 x pry bars – 204, 312, 458 and 608mm



Item Code	Bishops Code
9TK014	63518510

3 PIECE ROLLING HEAD (LADY FOOT) HEAVY DUTY PRY BAR SET

- Ideal for accurate positioning work
- Unique curved end enables better leverage in small confined areas
- Opposite end is designed for aligning work
- Manufactured from the highest quality alloy and carbon steel
- Fully heat treated shank for maximum strength and durability
- Corrosive resistant black oxide finish

Includes:

- 300, 400 & 530mm long bars



Item Code	Bishops Code
60150	63518512

4 PIECE ROLLING HEAD PRY BAR SET

- Steel construction
- Rolling head creates a higher level of leverage
- Tapered end is suitable for aligning work

Includes:

- Sizes: 6", 12", 16" & 20"



Description	Bishops Code
4 Piece Pry Bar Set	63518500

HEXAGON WRECKING BARS

- Used for construction, demolition and wrecking work
- Forged from tough high tensile carbon manganese steel
- Finely ground ends for good lead in, makes demolition work easier and quicker
- Open bend to get behind larger timbers, hex profile for greater control
- Wide and thin ends less likely to damage timbers when removing for restoration



Item Code	Size	Bishops Code
5WB45016	450(l) x 16(w)mm	63520540
5WB60020	600(l) x 20(w)mm	63520560
5WB75020	750(l) x 20(w)mm	63520570
5WB90020	900(l) x 20(w)mm	63520580

GOOSENECK WRECKING BARS

- Gooseneck end has a wide claw for prying and removing nails
- Chisel end is suitable for lifting and prying
- Forged from the highest quality carbon steel
- Fully heat treated shank for maximum strength and durability
- Corrosive resistant black oxide finish



Item Code	Body Dia.	Length	Weight	Bishops Code
41000	13mm	300mm	400g	63520410
41001	16mm	450mm	900g	63520420
41002	19mm	600mm	1.5kg	63520430
41003	19mm	750mm	1.8kg	63520440
41004	19mm	900mm	2.1kg	63520450

PODGER BARS

- Used for levering and aligning
- Forged from tough high tensile carbon manganese steel
- Heel set to 40° for optimum levering, blade ground to 30° for easy entry between surfaces
- Taper is forged, not turned, for maximum strength
- Hex profile bar for greater control and to minimise bar roll



Item Code	Size	Bishops Code
5POB45016	450(l) x 16(w)mm	63516520
5POB45020	450(l) x 20(w)mm	63516540
5POB60020	600(l) x 20(w)mm	63516560
5POB90020	900(l) x 20(w)mm	63516570

PODGER PINS

- Used for aligning and expanding holes in mild steel
- Forged from tough high tensile carbon manganese steel
- Forged head prevents pin being driven through the hole



Item Code	Size	Bishops Code
5POP16	16mm	63518562
5POP19	19mm	63538563
5POP22	22mm	63518564
5POP25	25mm	63518565
5POP30	30mm	63518570

GET MORE AT BISHOPS

SAFETY GLASSES

Page 13

SCALING BARS

- Used in the mining industry for prying overhanging rock
 - Heel offset to 40° for optimum levering
- 7SCT2400 & 7SCT3050:**
- Aluminium tube body for lighter weight and less user fatigue
 - Inserted steel ends forged from tough carbon manganese steel
- 7SC180019 & 7SC210019:**
- Forged from chrome alloy steel
 - Heat treated blades for maximum toughness
- Hexagonal profile for greater control



Item Code	Size	Bishops Code
7SC180019	1,500(l) x 20(w)mm	86410030
7SC210019	2,100(l) x 20(w)mm	86410040
7SCT2400	2,440(l) x 32(w)mm	86410010
7SCT3050	3,050(l) x 32(w)mm	86410020



CHISELS & CENTRE PUNCHES

HAND & CUTTING TOOLS

FLAT CHISELS

- Chrome vanadium alloy steel
- Phosphate sunk finishing



Item Code	Size	Weight	Bishops Code
76215-05	15 x 125mm	70g	63010610
76721-06	17 x 150mm	145g	63010620
76220-07	20 x 175mm	300g	63010630
76223-08	23 x 200mm	300g	63010640
76724-08	24 x 200mm	275g	63010642
76224-10	24 x 250mm	388g	63010650
76729-10	29 x 250mm	470g	63010660

4 PIECE FLAT CHISEL SET

- Supplied in a plastic case
- Weight: 1kg

Includes:

- 4 x flat chisels – 125, 150, 200 and 250mm



Item Code	Bishops Code
11104PR10	63010580

COLD CHISELS

- Octagonal cold chisels with impact proof polypropylene grip guards
- Chisels are individually forged from high quality alloy steel
- Suitable for use in all types of masonry and metal working applications
- Powder coated shank
- Cutting edge hardness: 52-58HRC
- Striking end hardness: under 42HRC



Item Code	Description	Bishops Code
CHS/ST/10/3-4/GRP/YE	Cold Chisel with Grip Guard – 250 x 19mm	63010628
CHS/ST/10/0-1/GRP	Cold Chisel with Grip Guard – 250 x 25mm	63010655
CHS/ST/6/ST	6 Piece Cold Chisel Set – 6, 8, 10, 13, 16 & 19mm	63010585

WOOD CHISEL SETS

- Heavy duty chisels for intensive use
- Thru tang design
- Full length blade guard
- Chrome alloy steel blade
- Steel strike cap can withstand use with a steel hammer
- Comes in convenient carry case



Item Code	Description	Bishops Code
2-16-268	3 Piece Chisel Set – 12, 18 & 25mm	62546445
2-16-269	5 Piece Chisel Set – 6, 12, 18, 25 & 32mm	62546450



PUNCH & CHISEL SETS

- Caters to the needs of the journeyman, farmer, rancher, mechanic and carpenter
- Octagonal cold chisels and heavy duty centre and drift punches
- Packed in heavy-duty vinyl rolls for easy access, organisation and storage
- Cold chisels and heavy duty punches
- Comes packed in a vinyl pouch



KIT/7/ST



KIT/24/ST



Item Code	Description	Bishops Code
KIT/7/ST	7 Piece – Includes: 3 x Cold Chisels – 13–19mm, 1 x Centre Punch – 4mm, 2 x Pin Punches – 3 & 5mm, 1 x Drift Punch – 4mm	63056600
KIT/24/ST	24 Piece – Includes: 7 x Cold Chisels – 6–22mm, 3 x Centre Punches – 2–6mm, 7 x Pin Punches – 1.5–8mm, 6 x Starting Punches – 1.5–8mm, 1 x Automatic Centre Punch – 13(dia) x 120mm	63056650

AUTOMATIC CENTRE PUNCH

- Heavy duty punch capable of very deep indentations
- Depth of the impression is adjustable by turning the knurled head
- Tips are hardened tool steel and are removable for maintenance and sharpening
- Spring loaded
- Non-slip grip
- Body diameter: 18mm
- Length: 146mm



Item Code	Bishops Code
ACP/H-2	63040580

CENTRE PUNCHES

- Chrome vanadium alloy steel
- Phosphate sunk finishing



Item Code	Size	Weight	Bishops Code
76103-04	3 x 100mm	34g	63040040
76104-05	4 x 120mm	59g	63040045
76105-06	5 x 150mm	116g	63040060

STARTER PUNCHES

- Chrome vanadium alloy steel
- Phosphate sunk finishing



Item Code	Size	Weight	Bishops Code
76304-05	4 x 120mm	60g	63042510
76305-05	5 x 120mm	64g	63042520
76306-05	6 x 120mm	64g	63042530
76308-05	8 x 120mm	100g	63042540
76310-06	10 x 150mm	132g	63042550

PIN PUNCHES

- Chrome vanadium alloy steel
- Phosphate sunk finishing



Item Code	Size	Weight	Bishops Code
76402-45	2 x 115mm	32g	63052310
76403-05	3 x 125mm	34g	63052320
76404-06	4 x 150mm	60g	63052330
76405-65	5 x 165mm	71g	63052350
76406-07	6 x 180mm	125g	63052360
76408-08	8 x 200mm	130g	63052370
76410-85	10 x 215mm	155g	63052380

CENTRE PUNCH & SET

- Manufactured from selected carbon steel and suitable for punching heavy duty materials
- Accurately hardened and tempered so that the point will withstand continuous use and the striking end will not splinter
- Ideal for clearly marking metal before drilling to ensure correct location of drill points
- Working tips are centered and ground to the correct angle (90° included angle) for increased efficiency in marking
- Striking end is chamfered to prevent breakage
- Hexagonal shank with premium powder coated finish
- Hardness: 52-58HRC



Item Code	Description	Bishops Code
CP/HD/1-4	Centre Punch – 138 x 6mm	63040700
CP/HD/5/ST	5 Piece Centre Punch Set – 2, 3, 4, 6 & 10mm	63040595

3 PIECE ROUND NAIL PUNCH SET

- Manufactured from selected carbon steel, hardened and tempered for longer service life
 - Knurled round shank with 9.5mm square head
 - Non-slip grip and black oxide finish
 - Designed for driving nail heads below the surface of the wood
- Includes:**
- Sizes: 0.80, 1.5 & 2.5mm



Item Code	Bishops Code
NLP/SQ/3/ST	62554090



7 PIECE DRIFT PUNCH STARTER SET



- Ideal for lining up holes in two or more pieces of metal and for drawing pins through various assemblies
 - Manufactured from selected carbon steel
 - Accurately hardened and tempered to withstand continuous use
 - Working ends are machine ground
 - Hexagonal shank with powder coated finish
- Includes:**
- Sizes: 3, 4, 5, 5.5, 6, 8 & 10mm



Item Code	Bishops Code
DFP/HD/7/ST	63042595

6 PIECE ROLL PIN PUNCH SET



- Punches are a single piece construction
 - Specifically designed to remove spring and roll pins
 - Comes packed in a vinyl pouch
- Includes:**
- Sizes: 2.5, 3, 4, 5, 6 & 8mm



Item Code	Bishops Code
RPP/6/ST	63052795

6 PIECE PIN PUNCH SET



- Weight: 0.57kg
- Includes:**
- Sizes: Ø2 x 30mm, Ø3 x 40mm, Ø4 x 50mm, Ø5 x 50mm, Ø6 x 50mm & Ø8 x 50mm



Item Code	Bishops Code
1006PR	63052390

9 PIECE PIN PUNCH SET



- Weight: 1.67kg
- Includes:**
- Sizes: Ø2 x 30mm, Ø3 x 40mm, Ø4 x 50mm, Ø5 x 50mm, Ø6 x 50mm, Ø8 x 50mm, Ø10 x 65mm, Ø12 x 70mm & Ø14 x 75mm



Item Code	Bishops Code
1009PR	63052392



PIN & HOLLOW PUNCHES & BARREL DRIFTS

HAND & CUTTING TOOLS

10 PIECE PIN PUNCH SET

- Weight: 0.86kg
- Includes:
 - 3 x Centre punches – Ø3 x 100mm, Ø4 x 120mm & Ø5 x 150mm
 - 4 x Pin punches – Ø3 x 120mm, Ø6 x 120mm & Ø8 x 120mm
 - 3 x Starter punches – Ø3 x 40mm, Ø4 x 50mm, Ø5 x 50mm & Ø6 x 50mm



Item Code	Bishops Code
1010PR	63052394

5 PIECE EXTRA LONG PIN PUNCH SET

- The extra long style is useful for applications where added leverage is required
- Hexagonal shank with powder coated finish
- Comes packed in a vinyl pouch
- Includes:
 - Sizes: 3, 5, 6, 8 & 10mm



Item Code	Bishops Code
PP/HD/5L/ST	63052780

BARREL DRIFTS

- Used for aligning holes in construction
- Also used for expanding holes in mild steel
- Forged from tough high tensile steel
- Taper is forged, not turned, for finer grain, giving greater tensile strength
- Reduced likelihood of scoring, even when driven hard
- Correctly heat treated to best suit product application



Item Code	Size	Bishops Code	Item Code	Size	Bishops Code
5BD12	12mm	*5BD12	5BD22	22mm	*5BD22
5BD14	14mm	*5BD14	5BD24	24mm	*5BD24
5BD16	16mm	*5BD16	5BD25	25mm	63518589
5BD18	18mm	*5BD18	5BD27	27mm	*5BD27
5BD19	19mm	*5BD19	5BD30	30mm	63518591
5BD20	20mm	*5BD20	5BD33	33mm	63518592

* – SPECIAL ORDER: PLEASE QUOTE ITEM CODE UPON ORDERING THIS PRODUCT

ROUND HOLLOW PUNCH SETS

- Suitable for punching round holes various soft materials such as leather, rubber, canvas and plastic
- Special design prevents material jamming inside the punch
- Cutting edge is induction hardened for longer service life
- Hardness: 40±50HRc



HPL/6/ST

Item Code	Description	Bishops Code
HPL/6/ST	6 Piece Hollow Punch Set In Vinyl Pouch – 5, 6, 8, 10, 11 & 12mm	63046690
HPL/14/ST	14 Piece Hollow & Arch Punch Set In Wooden Case – 6, 8, 10, 11, 13, 14, 16, 19, 22, 25, 30, 32, 35 & 38mm	63046698

WAD PUNCHES

- Suitable for punching holes in gasket material, leather, rubber, canvas, cardboard, plastic and other soft material
- Design of the cutting edge prevents jamming of material inside the punch
- Induction hardened cutting edge for extended working life
- Long shaft for convenient holding
- Hardness: 40 +/-50 HRc



INDIVIDUAL PUNCHES

Item Code	Size	Bishops Code	Item Code	Size	Bishops Code
HPL/6/BEL	6mm	63054306	HPL/22/BEL	22mm	63054322
HPL/8/BEL	8mm	63054308	HPL/25-B	25mm	63054325
HPL/10/BEL	10mm	63054310	HPL/28	28mm	63054328
HPL/12/BEL	12mm	63054312	HPL/32	32mm	63054332
HPL/16/BEL	16mm	63054316	HPL/35	35mm	63054335
HPL/19/BEL	19mm	63054319	HPL/38	38mm	63054338

SET

Item Code	Description	Bishops Code
HPL/7/BEL/ST	7 Piece Set – 6, 10, 12, 16, 19, 22 & 25mm	63054490

GET MORE AT BISHOPS



HAMMERS

From Page 222



GASKET MATERIAL

Page 459

NUMBER PUNCH SET

- Chrome vanadium alloy steel
- Hardened and tempered control HRC60 to provide safety in use
- The number 6 inverted becomes 9
- Number height: 5mm



Item Code	Bishops Code
11409SQ05	63050040

LETTER & NUMBER PUNCH SETS

- For hand held, hammer struck applications
- Manufactured from select quality carbon steel
- Punches are through induction hardened, providing durability and extended life for repeated use
- The hardness at the stamping end is maintained at 58-62HRC, the striking end is tempered to 35-42HRC, preventing the punch splintering during use
- Striking end is chamfered to prevent breakage and accidents due to flying splinters
- Come packed in a metal case
- Stamp size: 12mm/½"



Item Code	Description	Bishops Code
LP/12	Letter Punch Set	63048060
NP/12	Number Punch Set	63050150

LETTER & NUMBER PUNCH SETS

- Reverse image, raised characters
- Black metal finish



Description	Size	Bishops Code
Letter Punches – A to Z	3mm (1/8")	63048020
Letter Punches – A to Z	5mm (3/16")	63048040
Letter Punches – A to Z	6mm (1/4")	63048050
Number Punches – 0 to 9	5mm (3/16")	63050040

TYPES OF FILES

Hand Files are rectangular in shape. They are suitable for general filing work and finishing flat surfaces.

Flat Files are rectangular in shape but are narrower than hand files. Flat files are often bastard cut and maintain their thickness throughout their length. These files are recommended for general filing work.

Half Round Files have one flat and one convex side. They can either maintain their thickness throughout the length of the file or taper off. They are suitable for concave corners and round holes.

Round Files are round in shape and are often tapered off over their length (known as "rat tail files"). They are used for enlarging round holes or cutting scalloped edges.

Tri-Square Files are triangular in shape and often tapered over their length. Sides may be equal in size or have two long and one short.

Square Files are generally tapered and cut on all four sides. This shape is utilised for a variety of tasks such as enlarging holes or recesses.

Taper Files files have converging edges. They often come in tri-square shape and are used for sharpening saws.

Cut

Single Cut files have a single set of parallel, diagonal rows of teeth. Single cut files are used at a light pressure and create a smoother finish.

Double Cut files have two sets of diagonal rows of teeth. The coarse second cut runs in the opposite direction to the finer first cut. Use with heavier pressure to remove material faster than a single cut file.

Coarseness

Bastard Cut Used for fast material removal. Leaves a rough finish.

Second Cut A balanced coarseness between bastard and smooth.

Smooth Cut Between second cut and very smooth. Use single cut smooth files for finishing.





HAND FILES & SETS

HAND & CUTTING TOOLS

FLAT FILES

- Rectangular general purpose file
- Suitable for steel surfaces
- Handles available separately



Description	Size	Bishops Code	Description	Size	Bishops Code
Bastard Cut	150mm	49815115	Second Cut	250mm	49815325
Bastard Cut	200mm	49815120	Second Cut	300mm	49815330
Bastard Cut	250mm	49815125	Smooth Cut	150mm	49815515
Bastard Cut	300mm	49815130	Smooth Cut	200mm	49815520
Second Cut	150mm	49815315	Smooth Cut	250mm	49815525
Second Cut	200mm	49815320	Smooth Cut	300mm	49815530

HALF ROUND FILES

- Steel files suitable for use on steel surfaces
- Ideal for concave corners, crevices and round holes
- Third circular character of teeth
- Double cut
- Handles available separately



Description	Size	Bishops Code	Description	Size	Bishops Code
Bastard Cut	200mm	49820120	Second Cut	350mm	49820335
Bastard Cut	250mm	49820125	Smooth Cut	150mm	49820515
Bastard Cut	300mm	49820130	Smooth Cut	200mm	49820520
Second Cut	200mm	49820320	Smooth Cut	250mm	49820525
Second Cut	250mm	49820325	Smooth Cut	300mm	49820530
Second Cut	300mm	49820330	-	-	-

ROUND FILES

- Steel files suitable for use on steel surfaces
- For enlarging holes and shaping curved surfaces
- Either tapered or blunt
- Double cut
- Handles available separately



Description	Size	Bishops Code	Description	Size	Bishops Code
Bastard Cut	200mm	49825120	Second Cut	350mm	49825335
Bastard Cut	250mm	49825125	Smooth Cut	100mm	49825510
Bastard Cut	300mm	49825130	Smooth Cut	150mm	49825515
Second Cut	150mm	49825315	Smooth Cut	200mm	49825520
Second Cut	200mm	49825320	Smooth Cut	250mm	49825525
Second Cut	250mm	49825325	Smooth Cut	300mm	49825530
Second Cut	300mm	49825330	-	-	-

CHAINSAW FILES

- Steel round files
- Designed for sharpening teeth on chainsaw chains



Diameter	Bishops Code
5/32"	49860140
3/16"	49860150
7/32"	49860155

4 PIECE HAND FILE SETS

- Bastard cut and second cut options
 - Length: 250mm
- Includes:
- 1 x Half round file
 - 1 x Round file
 - 1 x Flat file
 - 1 x Square file



49880510

Description	Bishops Code
4 Piece Bastard Cut File Set	49880500
4 Piece Second Cut File Set	49880510

12 PIECE NEEDLE FILE SET

- Steel files
- Assorted cuts
- Plastic handle included
- Length: 160mm



Item Code	Bishops Code
2850007	49880560

GET MORE AT BISHOPS

EXTERNAL THREAD FILES

Page 275

EMERY PAPER

Page 127

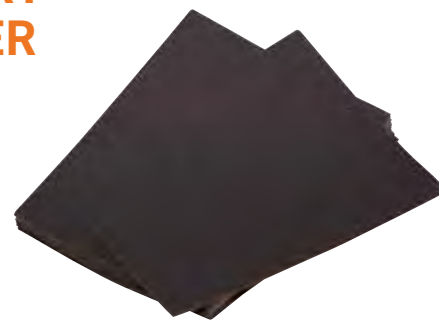

THE USUAL SUSPECTS – A LINE-UP OF THE MOST COMMON HAMMERS



- 1 **Claw Hammers** can be used to pry out nails and the like by lever action. A great general purpose hammer.
- 2 **Ball Pein Hammers**, often used by engineers, have a rounded head suitable for shaping metal, closing rivets or rounding off metal edges.
- 3 **Club Hammers** are used like a miniature sledge hammer. Useful for demolition and general striking, also used for driving cold chisels.
- 4 **Sledge Hammers** allow significant impact speed with a long, extended handle. Suitable for breaking up rocks and heavy duty impact work. Make sure to choose a normalised head if striking hardened steel tools or surfaces.
- 5 **Mallets** are often soft faced with non-ferrous materials including copper, rawhide, nylon, rubber or a combination. They deliver firm blows that won't risk damage to expensive components.
- 6 **Dead Blow Hammers** have internal features that greatly reduce rebound, allowing for powerful yet accurate work in tight spaces.
- 7 **Prospecting Picks** are used for breaking up rocks. The pick end is useful for striking into existing cracks.

All hammers and striking tools should always be used with the proper PPE and safety gear.

If you have any questions about best safety practices make sure to contact Bishops.

GET MORE AT BISHOPS ▶



**TOOL
BOXES**

Page 160



CLAW HAMMERS

HAND & CUTTING TOOLS

WOODEN HANDLE CLAW HAMMER

- Drop forged hardened steel head
- Traditional wooden handle



Item Code	Bishops Code
51-534	62541230

STEEL CLAW HAMMER

- One piece forged steel handle
- Polished drop forged carbon steel head
- Hardened and tempered
- Slip resistant rubber grip
- Weight: 800g (28oz)



Item Code	Bishops Code
51-091	62541210

CLAW HAMMER

- Single piece claw hammer
- Comfort grip handle
- Weight: 565g (20oz)



Item Code	Bishops Code
W041033	63521090

FIBREGLASS HANDLE CLAW HAMMER

- Fibreglass handle
- Comfort grip
- Weight: 680g (24oz)



Item Code	Bishops Code
W041062	63521093

WHICH HANDLE? WOOD, STEEL OR FIBREGLASS?

Wood Handled Hammers are a good economical option but may break if excessively used. Unsleeved, the grip is more slippery than other types.

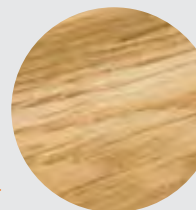

Steel Handled Hammers are the most durable, but also the heaviest of the types. They will deliver a powerful blow and offer excellent durability.



Fibreglass Handled Hammers are the lightest type over steel and wood. They have shock absorbing characteristics which transmit less vibration to the user.



Can't find the hammer you're looking for? Give Bishops a call!

FIBREGLASS CLAW HAMMER

- Fibreglass handle to absorb shock and vibration
- Forged carbon steel head
- Non-slip rubber grip
- Weight: 800g (28oz)



Item Code	Bishops Code
51-072	62541220

ANTI-VIBRATION CLAW HAMMER

- Large strike face
- Anti-vibration grip for less user fatigue
- Weight: 565g (20oz)



Item Code	Bishops Code
FMHT1-51277	62541200

BALL PEIN HAMMERS

- High quality alloy steel
- Forged and hardened steel
- Wood and metal wedge
- GGG, H86C



Item Code	Face Dia.	Head Length	Head Weight	Length	Weight	Bishops Code
7811-08	25mm	80mm	245g	300mm	375g	61003108
7811-12	29mm	93mm	370g	300mm	485g	61003112
7811-16	32.5mm	103mm	485	353mm	640g	61003116
7811-24	35.5mm	122mm	765g	405mm	975g	61003124
7811-32	40.5mm	125mm	925g	405mm	1.20kg	61003132
7811-40	42.2mm	133mm	1.125kg	405mm	1.395kg	61003140

BALL PEIN HAMMER

- Forged high-carbon steel head
- Fully heat treated and polished face
- Textured grip
- Hickory handle
- Weight: 680g (24oz)



Item Code	Bishops Code
W041030	63521087

**FAST FACT
– WHAT IS A
NORMALISED HEAD?**

Many steel tools and components are **hardened** for strength and durability. Tools such as hammers, punches, drill bits and chisels are examples where hardened steel is common.

The sudden impact of hardened steel against hardened steel can cause metal shards to splinter and fly off at great speed and danger. There have been injuries and fatalities and the utmost care must be taken when using steel striking tools.

Using a hammer with a **normalised face** can significantly reduce the risk of flying chips. Normalising is a metalworking process that reduces hardness and makes steel less brittle.

A normalised hammer head is designed to mushroom (splay) rather than crack or splinter. Normalised hammers can be identified by the S marked on their head.



BALL PEIN HAMMERS

- Useful for engineers and used in metal work for striking punches and chisels
- Also used for riveting work with hammer ball end
- Hardened and tempered steel head (above 50HRC) gives precision striking force, durability and longevity
- Unique reinforced, ribbed design, shock absorbing fibreglass handle
- Steel wedged hammer head holds more than 6000N of pull force and in accordance with BS 876:1995
- CNC machined face gives the smoothest striking
- Tether hole feature for extra safety when using a tether and working at height surface



Item Code	Head Weight	Handle Length	Total Weight
6HBP5GFH0.450	453g (16oz)	330mm	680g
6HBP5GFH0.675	675g (24oz)	360mm	950g
6HBP5GFH0.900	900g (32oz)	370mm	1.25kg

SPECIAL ORDER: PLEASE QUOTE ITEM CODE UPON ORDERING THIS PRODUCT

NORMALISED BALL PEIN HAMMERS

- Useful for engineers and used in metal work for striking punches and chisels
- Normalised hammer head features a softer face (below 20HRC) that will mushroom – ideal for applications where the risk of chipping needs to be minimised
- Unique reinforced, ribbed design, shock absorbing fibreglass handle
- Steel wedged hammer head holds more than 6000N of pull force and in accordance with BS 876:1995
- CNC machined face gives the smoothest striking
- Tether hole feature for extra safety when using a tether and working at height surface



Item Code	Head Weight	Handle Length	Total Weight
6NHBP5GFH0.450	453g (16oz)	330mm	680g
6NHBP5GFH0.675	675g (24oz)	360mm	950g
6NHBP5GFH0.900	900g (32oz)	370mm	1.25kg

SPECIAL ORDER: PLEASE QUOTE ITEM CODE UPON ORDERING THIS PRODUCT

NON-SPARKING BALL PEIN HAMMERS

- For use in potentially explosive environments
- Forged after casting to provide higher mechanical properties
- Weight: 700g



Item Code	Description	Bishops Code
70490	Copper Beryllium	61003186
71745	Aluminium Bronze	61003188

INDESTRUCTIBLE HANDLE BALL PEIN HAMMERS

- Indestructible handle made up of 2 spring steel bars
- Bars locked with hammer head using steel locking plate ensuring that the head never gets dislodged
- Ergonomic rubber grip handle absorbs vibration



Item Code	Weight	Bishops Code
BPID/24/14	720g (24oz)	61003182
BPID/32/14	950g (32oz)	61003184



CLUB & SLEDGE HAMMERS

HAND & CUTTING TOOLS

CLUB/LUMP HAMMERS

- High quality alloy steel
- DIN6475



Item Code	Face Dia.	Head Length	Head Weight	Length	Weight	Bishops Code
7833-15	45mm	110mm	1.5kg	280mm	1.77kg	63532020
7833-20	50mm	120mm	2.0kg	300mm	2.14kg	63532040

INDESTRUCTIBLE HANDLE CLUB HAMMERS

- The indestructible handle is made from four spring steel bars running through the length of the handle
- Ergonomic rubber grip absorbs vibration and reduces fatigue
- The head is locked to the handle with steel locking plates, ensuring the head never becomes dislodged
- The hammer head is forged from special steel and induction case hardened 52-56HRC
- Ideally suited for demolition work where the struck surface is softer than the hammer head



Item Code	Length	Weight	Bishops Code
CHID/2.5/12	300mm (12")	1.1kg	63532010
CHID/4/12	300mm (12")	1.8kg	63532012
CHID/4/16	400mm (16")	1.8kg	63532014

INDESTRUCTIBLE HANDLE COPPER HEAD HAMMERS

- The indestructible handle is made from four spring steel bars running through the length of the handle
- Ergonomic rubber grip absorbs vibration and reduces fatigue
- The head is locked to the handle with steel locking plates, ensuring the head never becomes dislodged
- The head is forged from 99.9% pure copper reducing sparking and marring during use



Item Code	Description	Handle Length	Weight	Bishops Code
CHID/4/12/CU	Club Hammer	300mm	1.8kg	63532018
SHID/8/24/CU	Sledge Hammer	600mm	3.6kg	63534096
SHID/14/30/CU	Sledge Hammer	750mm	6.3kg	63534098



SLEDGE HAMMERS

- Well balanced versatile sledge hammer for the building and construction industry
- Forged from tough high tensile carbon manganese steel
- Hardened and tempered faces for increased product life
- Head secured with wooden and metal wedges for added safety
- 5HSH14 is fitted with a tough Australian spotted gum hardwood handle, oiled for long life and user comfort
- Extra thick shoulder to prevent breakages from mis-hits
- 5HSFRH14 is fitted with a fibreglass handle with large sweep at base to prevent loss of grip
- Comfortable thick rubber grip for better protection from shock and vibration
- Weight: 6.3kg (14lb)



Product Code	Description	Bishops Code
5HSH14	Wooden Handle	63534090
5HSFRH14	Fibreglass Handle	63534092

FIBREGLASS SLEDGE HAMMERS

- Fibreglass handle with rubber grip
- Steel hammer head



Weight	Bishops Code
1.8kg (4lb)	63534020
3.6kg (8lb)	63534040
4.5kg (10lb)	63534060
5.4kg (12lb)	63534080

INDESTRUCTIBLE HANDLE SLEDGE HAMMERS

- The indestructible handle is made from four spring steel bars running through the length of the handle
- Ergonomic rubber grip absorbs vibration and reduces fatigue
- The head is locked to the handle with steel locking plates, ensuring the head never becomes dislodged
- Heavy duty 52HRC head is forged from special steel and ideally suited for demolition work where the struck surface is softer than the hammer head
- The soft face head is forged from special steel and case hardened 30-35HRC
- The softer head is designed to mushroom on impact preventing damage to the struck surfaces
- 750mm (30") handle



Item Code	Description	Weight	Bishops Code
SHID/6/30	Heavy Duty 52 HRC Head	2.7kg	63534082
SHID/8/30	Heavy Duty 52 HRC Head	3.6kg	63534084
SHID/10/30	Heavy Duty 52 HRC Head	4.5kg	63534086
SHID/12/30	Heavy Duty 52 HRC Head	5.5kg	63534087
SHID/14/30	Heavy Duty 52 HRC Head	6.3kg	63534088
SHID/SF/10/30	Soft Face 30 HRC Head	4.5kg	63534112
SHID/SF/12/30	Soft Face 30 HRC Head	5.5kg	63534113

SLEDGE HAMMERS

- Well-balanced versatile sledge hammer for building, construction, mining and demolition work
- Hardened and tempered steel head (above 50HRC) gives precision striking force, durability and longevity
- Unique reinforced, ribbed design, shock absorbing fibreglass handle
- Steel wedged hammer head holds more than 11,000N of pull force and in accordance with BS 876:1995
- CNC machined face gives the smoothest striking surface
- Tether hole feature for extra safety when using a tether and working at height

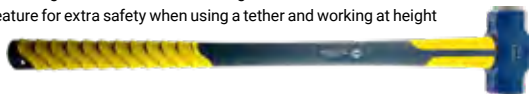

Item Code	Head Weight	Handle Length	Total Weight
9HS5GFH1.8	1.8kg (4lb)	380mm	2.15kg
9HS5GFH3.5	3.15kg (7lb)	900mm	4.53kg
9HS5GFH4.5	4.5kg (10lb)	900mm	5.89kg
9HS5GFH6.3	6.3kg (14lb)	900mm	7.71kg

SPECIAL ORDER: PLEASE QUOTE ITEM CODE UPON ORDERING THIS PRODUCT

NORMALISED SLEDGE HAMMERS

- Well-balanced versatile sledge hammer for building, construction, mining and demolition work
- Normalised hammer head features a softer face (below 20HRC) that will mushroom – ideal for applications where the risk of chipping needs to be minimised
- Unique reinforced, ribbed design, shock absorbing fibreglass handle
- Steel wedged hammer head holds more than 11,000N of pull force and in accordance with BS 876:1995
- CNC machined face gives the smoothest striking surface
- Tether hole feature for extra safety when using a tether and working at height



Item Code	Head Weight	Handle Length	Total Weight
9NHS5GFH1.8	1.8kg (4lb)	380mm	2.15kg
9NHS5GFH3.5	3.15kg (7lb)	900mm	4.53kg
9NHS5GFH4.5	4.5kg (10lb)	900mm	5.89kg
9NHS5GFH6.3	6.3kg (14lb)	900mm	7.71kg

SPECIAL ORDER: PLEASE QUOTE ITEM CODE UPON ORDERING THIS PRODUCT

NON-SPARKING COPPER SLEDGE HAMMERS

- Suitable for use in non-sparking environments and for applications where risk of chipping needs to be minimised
- Forged from pure electrolytic copper for a softer blow and pinned through steel core fibreglass handle for added safety
- Comfortable thick rubber grip for better protection from shock and vibration
- Lanyard hole in handle
- Handle length: 900mm



Item Code	Head Weight	Bishops Code	Item Code	Head Weight	Bishops Code
5HCFRH06900	2.7kg (6lb)	63536904	5HCFRH14	6.35kg (14lb)	63534100
5HCFRH07	7lb	*5HCFRH07	5HCFRH28	28lb	*5HCFRH28
5HCFRH10	10lb	*5HCFRH10	-	-	-

* - SPECIAL ORDER: PLEASE QUOTE ITEM CODE UPON ORDERING THIS PRODUCT

NON-SPARKING COPPER SLEDGE HAMMERS

- Suitable for use in non-sparking environments and for applications where risk of chipping needs to be minimised
- Copper heads are softer than brass and reduce damage made to threads
- Hammer heads are pinned through the steel core of fibreglass handles for added safety
- Steel core is immersed in glue, with the pin in a blind hole to avoid sparking



Item Code	Head Weight	Bishops Code	Item Code	Head Weight	Bishops Code
5HCH01	1lb	*5HCH01	5HCH03	1.36kg (3lb)	63532042
5HCH02	2lb	*5HCH02	5HCH04	1.81kg (4lb)	63022080

* - SPECIAL ORDER: PLEASE QUOTE ITEM CODE UPON ORDERING THIS PRODUCT

NON-SPARKING COPPER SLEDGE HAMMERS



- For use in potentially explosive environments
- Forged after casting to provide higher mechanical properties
- Weight: 1kg



Item Code	Bishops Code
72751	63536902

DEAD BLOW HAMMERS

- Solid rubber



Item Code	Face Dia.	Head Length	Head Weight	Length	Weight	Bishops Code
7851-32	55mm	100mm	0.908kg	342mm	1.090kg	63020160
7851-40	58mm	110mm	1.134kg	342mm	1.218kg	63020170
7851-48	61mm	123mm	1.361kg	355mm	1.511kg	63020180

GET MORE AT BISHOPS



EARMUFFS

Page 26

THOR COPPER HAMMERS

- The malleable iron head and cylindrical faces of copper combine to provide the weight for the blow
- The copper faces prevent damage to expensive machined sub components and assemblies
- Ideal where a heavy blow is required within a relatively small striking area
- Faces are designed to wear and can be replaced
- Used as a general purpose soft-faced hammer in automotive and general engineering for assembly, repair and maintenance

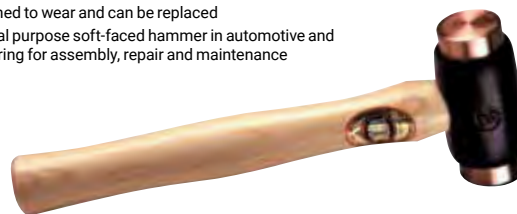

Item Code	Face Dia.	Weight	Bishops Code
TH310	32mm	850g	63022310
TH312	38mm	1.30kg	63022320
TH314	44mm	1.97kg	63022330
TH316	50mm	2.95kg	63022340



SOFT-FACE MALLETS & HAMMERS

HAND & CUTTING TOOLS

RUBBER Mallet

- Fibreglass handle with rubber head and grip
- Head size: 76 x 127mm
- Head weight: 900g (32oz)
- Length of handle: 250mm
- Overall length: 330mm



Bishops Code
63030380

RUBBER Mallet

- Tough rubber head moulded to a lacquered wooden handle
- Head weight: 680g (24oz)
- Overall length: 350mm



Item Code 57.528 Bishops Code 63030330

RUBBER MALLETS

- Used for metalworking, tiling and automotive work
- Durable rubber head for longer life
- White rubber head for non-marking applications
- Soft faced hammers help reduce damage to striking surface
- Includes tether hole for working at heights
- High-visibility yellow non-slip comfort grip



WHITE		BLACK	
Item Code	Weight	Item Code	Weight
5RMFG16W	450g	5RMFG16B	450g
5RMFG24W	680g	5RMFG24B	680g
5RMFG32W	900g	5RMFG32B	900g

SPECIAL ORDER: PLEASE QUOTE ITEM CODE UPON ORDERING THIS PRODUCT

NYLON SOFT-FACE HAMMERS

- Replaceable hammer face
- Nylon tips reduce damage to striking surface
- Shot-filled head to minimise rebound
- High-visibility yellow non-slip comfort grip



Item Code	Weight
5HSFNT30	690g
5HSFNT40	830g
5HSFNT50	1.09kg

SPECIAL ORDER: PLEASE QUOTE ITEM CODE UPON ORDERING THIS PRODUCT

SOFT FACED HAMMERS – COMMON MATERIALS

Copper, as a much softer metal than steel, will deform first, avoiding damage to delicate and critical components.

Rawhide faces are useful for regulating impact force and delivering gentle yet firm blows. Enjoy increased safety, reduced noise and the versatility of rotatable and replaceable faces.

Rubber faced hammers are highly versatile and often employed in woodworking. The common black rubber can mark a surface, so make sure to use a non-marking grey rubber in critical applications.

Nylon faces are ideal for striking harder metals such as steel or delivering non-marring blows. Nylon also has excellent inherent chemical resistance.



SOFT FACE HAMMERS



- Changeable head
- Polyurethane
- High quality alloy steel



Item Code	Face Dia.	Head Length	Length	Weight	Bishops Code
7842-22	22mm	75mm	255mm	110g	63026310
7842-35	35mm	100mm	325mm	305g	63026330
7842-45	45mm	112mm	335mm	420g	63026350
7842-60	60mm	135mm	380mm	895g	63026360

REPLACEMENT FACES – SOFT			REPLACEMENT FACES – HARD		
Item Code	Size	Bishops Code	Item Code	Size	Bishops Code
91522S	22mm	63026580	91522H	22mm	63026590
91528S	28mm	63026600	91535H	35mm	63026620
91535S	35mm	63026630	91545H	45mm	63026650
91545S	45mm	63026670	91560H	60mm	63026660
91560S	60mm	63026640	-	-	-

REPLACEMENT HAMMER TIPS

- Nylon and PVC hammer tips to suit 5HSNT Soft Face Hammers



NYLON		PVC	
Item Code	Size	Item Code	Size
5HNT30	30mm	5HPT30	30mm
5HNT40	40mm	5HPT40	40mm
5HNT50	50mm	5HPT50	50mm

SPECIAL ORDER: PLEASE QUOTE ITEM CODE UPON ORDERING THIS PRODUCT

HAND SAWS

- Precision ground teeth
- Length: 550mm (22")
- 7tpi



Item Code	Description	Bishops Code
W016014	Wooden Handle Saw	63521025
W016035	Comfort Grip Handle Saw	63521028

GENERAL PURPOSE HANDSAW

- Hardened teeth
- 45° and 90° angle guides
- Soft grip handle



Item Code	Bishops Code
20-074	62546350

HEAVY DUTY HANDSAW

- Triple ground teeth cut on the push and pull
- 45° and 90° angle guides
- Moulded plastic handle with rubber grip for comfort
- Suitable for use on hardwood, green wood, OSB/chip board, honeycomb panel and foam insulation
- Blade thickness: 0.85mm
- Blade length: 550mm
- 8tpi



Item Code	Bishops Code
STHT1-20352	62546340

MITRE BOX HAND SAW

- Reinforced steel blade
- Comfort grip handle
- Length: 405mm (16")
- 12tpi



Item Code	Bishops Code
W016040	63521035

MITRE BOX

- Heavy duty plastic mitre box
- Attachment points for fixing to work bench
- Guides for cutting 45° and 90° angles



Item Code	Bishops Code
W016044	63521038

JUNIOR HACKSAW



- Quality steel wire frame
- Designed to ensure correct alignment and perfect blade tension during use
- Blade holders prevent the blade protruding from the ends
- Easy to replace blades
- Finished with rust inhibiting powder coating
- Bow depth: 60mm
- 260(l) x 70(h)mm



Item Code	Bishops Code
JHF/4PD/BU	63015020

HEAVY DUTY HACKSAW

- Aluminium alloy frame
- Quick release changeable blade
- Length: 305mm (12")



Item Code	Bishops Code
W016009	63521020

HACK SAWS



- Sliding metal bow
- Acrylonitrile butadiene styrene (ABS) + thermoplastic rubber (TPR) handle
- Lightweight and anti-slippery
- Spare blades can be stored
- Adjustable blade length: 305mm



Item Code	Blade Positions	Length	Weight	Bishops Code
7911-12	45° & 90°	400mm	628g	63015040
7921-12	45°, 90°, 135° & 180°	510mm	555g	63015050



UTILITY CUTTERS, KNIVES & BLADES

HAND & CUTTING TOOLS

SAFETY CUTTER

- 'Beak' shape design
- Can be used by both left and right-handed users
- Suitable for cutting through packaging, shrink wrap and most plastic straps
- Features an acetone and impact-resistant handle
- Replacement blades sold separately



Description	Bishops Code
Safety Cutter	62547022
Replacement Blades - 10 Pack	62547158

SAFETY KNIFE

- Designed with an auto-retracting blade for extra safety while cutting
- Features a powerful return spring and a stainless steel blade channel
- Ergonomic grip for extra comfort
- Suitable for cutting corrugated boxes, paper, cartons and other packaging material
- Can be used by left and right handed users
- Replacement blades sold separately



Description	Bishops Code
Safety Knife	62547021
Replacement Blades - 5 Pack	62547157

HEAVY DUTY CUTTING KNIFE

- Single handed blade with side-locking mechanism
- Suitable for cutting cardboard, roofing, drywall, vinyl, acetates and more
- Replacement blades sold separately



Description	Bishops Code
Cutting Knife	62547024
Replacement Blades - 10 Pack	62547159

AUTOMATICALLY RELOADING UTILITY CUTTER

- Automatically reloading snap-off blades
- Ergonomic soft acrylonitrile butadiene styrene (ABS) thermoplastic rubber (TPR) handle
- Stainless steel blade guide
- Blade lock knob
- 4 blade cartridge (18mm)
- Length: 165mm
- Weight: 180g



Item Code	Description	Bishops Code
7971-07	Automatically Reloading Utility Cutter	62547025
7971-07PO2	Replacement Snap-Off Blades - 10 Pack	62547155



PRO SERIES FOLDING UTILITY KNIFE

- 150mm aluminium folding utility knife
- Ideal for heavy industrial use
- Rugged anodised aluminium handle
- Stainless steel mechanism and components
- Quick change button for easy blade changes
- Lock back design, locks open and closed for safety
- Compact lightweight design
- Uses most standard utility knife blades



Description	Bishops Code
150mm Folding Utility Knife	62547010

TRADE SERIES RETRACTABLE UTILITY KNIFE

- Ideal for trade use
- Razor sharp tempered SK5 blade
- Ergonomic contoured and textured grip
- Strong and lightweight aluminium alloy housing
- Multi-position retractable blade for all purpose cutting
- Built in blade chamber stores up to five blades
- Lanyard attachment point
- Five utility blades included



Description	Bishops Code
Retractable Utility Knife	62547065
Replacement Blades - 10 Pack	62547163

HEAVY DUTY AUTO-RETRACT UTILITY KNIFE

- Heavy duty metal construction with comfortable rubber grip
- Blade safely retracts, even when the thumb is left on the blade slider
- Easy to change blade, no tools required



Item Code	Bishops Code
91868080	62547050

SAFETY SERIES AUTO-RETRACT UTILITY KNIFE

- Ideal for trade and industrial use
- Auto-retracting steel blade
- Ergonomic contoured and textured grip
- Strong and lightweight aluminium alloy housing
- Oversized blade button
- Easy blade change, no tools required
- Built-in blade chamber stores up to five blades
- Five safety rounded point blades included
- Hi-vis orange for extra visibility



Description	Bishops Code
Auto-Retract Safety Knife	62547070
Replacement Blades - 10 Pack	62547170

BOLSTERED GASKET SCRAPER



- Length: 218mm



Item Code	Blade Width	Weight	Bishops Code
9CJ2112	32mm	120g	62560514
9CJ2120	50mm	140g	62560520

PINCHWELD SCRAPER



- Blade width: 19mm
- Length: 168mm
- Weight: 75g



Item Code	Bishops Code
9CJ3106	62560534

BOLSTERED BENT SCRAPER



- Blade width: 32mm
- Length: 218mm
- Weight: 120g



Item Code	Bishops Code
9CJ2212	62560524

WINDOW SCRAPER

- Removes paint, glue, putty or adhesives
- Comfort grip with retractable razor blade
- Comes blister packed with blade cover
- Blade width: 55mm
- Overall length: 150mm

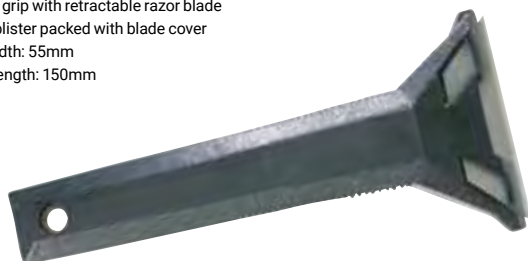

Item Code	Bishops Code
SCR-L	62560940

PAINT SCRAPERS

- Comes with Duragrip handle and steel blades
- Blades are fixed



Blade Width	Bishops Code	Blade Width	Bishops Code
38mm	62560030	90mm	62560375
50mm	62560050	100mm	62560400
65mm	62560100	-	-

INDUSTRIAL MULTI-TOOL PLIERS

- Stainless steel
- Compact folding design
- Features 15 handy tools for general purpose use
- Comes with nylon pouch



Item Code	Bishops Code
W014004	63521000

GET MORE AT BISHOPS

BROOMS

Page 405



HAND CLEANERS

Page 399





SCREWDRIVERS – PHILLIPS OR SLOTTED?

KING TONY MAKES IT EASY TO GRAB THE RIGHT TOOL!



Phillips screwdriver handles are coloured red.

Slotted screwdriver handles are coloured blue.

Insulated screwdriver handles are coloured yellow and red.

Be careful! Always make sure your insulated tools are genuine and certified.



8 PIECE PRECISION SCREWDRIVER SET



- Weight: 0.24kg
- Includes:**
 - 4 x Precision Phillips screwdrivers – PH000 x 40mm, PH00 x 40mm, PH0 x 40mm & PH1 x 40mm
 - 4 x Precision slotted screwdrivers – 1.5 x 40mm, 2.0 x 40mm, 2.5 x 40mm & 3.0 x 40mm



Item Code	Bishops Code
32108	61026320

8 PIECE PRECISION SCREWDRIVER SET



- Weight: 0.32kg
- Includes:**
 - 4 x Precision Phillips screwdrivers – PH000 x 75mm, PH00 x 75mm, PH0 x 75mm & PH1 x 75mm
 - 4 x Precision slotted screwdrivers – 1.5 x 75mm, 2.0 x 75mm, 2.5 x 75mm & 3.0 x 75mm



Item Code	Bishops Code
32118MR	61026340

4-IN-1 LED SCREWDRIVER SET

- Compact screwdriver set
- Handy size for storing in a tool box
- Suitable for DIY and general purpose use
- Interchangeable tips and bits



Item Code	Bishops Code
W021174	63521043

6 PIECE HEAVY DUTY TANG-THRU SCREWDRIVER SET



- Shank material: SNCM + V alloy steel
- Polypropylene + thermoplastic rubber (TPR) grip
- Chrome plated with black tips finishing
- Weight: 1.2kg

- Includes:**
- 3 x Heavy duty Phillips screwdrivers – PH1 x 75mm, PH2 x 100mm & PH3 x 150mm
 - 3 x Heavy duty slotted screwdrivers – 5.5 x 100mm, 6.5 x 150mm & 8.0 x 175mm



Item Code	Bishops Code
30206MR	61026806

7 PIECE SCREWDRIVER SET



- Weight: 0.72kg
- Includes:**
 - 2 x Phillips screwdrivers – PH1 x 80mm & PH2 x 100mm
 - 5 x slotted screwdrivers – 3 x 75mm, 4 x 100mm, 5.5 x 125mm, 6.5 x 150mm & 8 x 175mm



Item Code	Bishops Code
30117MR	61026107

8 PIECE SCREWDRIVER SET

- Chrome-vanadium steel
- Comfort grip handle

- Includes:**
- 4 x Phillips screwdrivers
 - 4 x Slotted screwdrivers



Item Code	Bishops Code
W000801	63521040

11 PIECE TWO-WAY SCREWDRIVER SET

- Chrome vanadium alloy steel shank
- Polypropylene + thermoplastic rubber (TPR) grip
- Chrome plated finishing
- Shank length: 125mm
- Blow case size: 233(l) x 120(w) x 43(h)mm
- Weight: 0.7kg

Includes:

- 1 x Phillips long head double end power bit – PH1 x PH2
- 1 x Pozidriv long head double end power bit – PZ1 x PZ2
- 2 x Slotted long head double end power bits – 4 x 6mm & 5 x 7mm
- 3 x Torx long head double end power bits – T10 x T15, T20 x T25 & T30 x T40
- 3 x Hex ball long head double end power bit – 4 x 4, 5 x 5 & 6 x 6
- 1 x Reversible screwdriver handle



Item Code	Bishops Code
32518MR	61026104

9-IN-1 RATCHET SCREWDRIVER SET



- Non-magnetic
- Handle made from thermoplastic vulcanisate and polypropylene
- Bits stored conveniently in the end cap of the screwdriver handle
- Weight: 0.4kg

Includes:

- 2 x 1/4" Slotted hex bits – 4 & 5mm
- 3 x 1/4" Phillips hex bits – PH1, PH2 & PH3
- 2 x 1/4" Pozidriv hex bits – PZ1 & PZ2
- 1 x Reversible ratchet
- 1 x 1/4" Bit holder



Item Code	Bishops Code
32809MR	61026101

8 PIECE 1,000V INSULATED ROTORK SCREWDRIVER SET



- Insulated to 1,000V

Includes:

- 4 x Slotted head screwdrivers – 3 x 100, 4 x 125, 5 x 150 & 6 x 150mm
- 2 x Phillips head screwdrivers – PH1 x 100mm & PH2 x 125mm
- 2 x Pozidriv screwdrivers – PZ1 x 100mm & PZ2 x 125mm



Item Code	Bishops Code
76685	61026920

7 PIECE 1,000V INSULATED SCREWDRIVER SET



- SNCM + V alloy steel shank
- Polypropylene + thermoplastic rubber (TPR) grip
- Chrome plated with black tip finishing
- Weight: 0.86kg

Includes:

- 3 x Insulated Phillips screwdrivers – PH1 x 100mm, PH2 x 100mm & PH3 x 150mm
- 4 x Insulated slotted screwdrivers – 4 x 100mm, 5.5 x 125mm, 6.5 x 150mm & 8.0 x 175mm



Item Code	Bishops Code
30617MR	61026910

14 PIECE STANDARD & INSULATED SCREWDRIVER SET



- Used in the working environment less than 60°C
- Chromium vanadium alloy steel shank
- PVC handle grip
- Chrome plated finish
- Weight: 2.2kg

Includes:

- 6 x Phillips screwdrivers – PH0 x 75mm, PH1 x 100mm, PH2 x 100mm, PH2 x 150mm, PH2 x 38mm & PH3 x 150mm
- 6 x Slotted screwdrivers – 3 x 75mm, 4 x 100mm, 5.5 x 100mm, 6.5 x 150mm, 6.5 x 38mm & 8 x 200mm
- 1 x Insulated screwdriver – 6.5 x 150mm
- 1 x Heavy duty screwdriver – 10 x 300mm



Item Code	Bishops Code
35114MR	61026520

1/4" DRIVE TORQUE SCREWDRIVER



- 6.3mm (1/4") hex driver for bit
- Automatic adjustment knob design
- Easy to read laser scale
- Ergonomic comfort rubber grip
- Torque range: 1–6Nm
- Increments: 0.1Nm
- Length: 248mm
- Weight: 475g
- Tolerance of torque ±5% quality meets DIN ISO 6789 and ASME B107.14M-2004



Item Code	Bishops Code
34111-2DG	63070004



SCREWDRIVERS

HAND & CUTTING TOOLS

PHILLIPS SCREWDRIVERS



- SNCM + V alloy steel shank
- Polypropylene + thermoplastic rubber (TPR) grip
- Chrome plated finish with black tip
- Round shank
- DIN ISO 8764



Item Code	Size	Shank Length	Bishops Code
14210023	PH0	60mm	61024520
14210132	PH1	80mm	61024540
14210104	PH1	100mm	61024560
14210112	PH1	300mm	61024575
14210214	PH2	38mm	61024580
14210204	PH2	100mm	61024600
14210206	PH2	150mm	61024610
14110208-E	PH2	200mm	61024612
14210212	PH2	300mm	61024615
14210306	PH3	150mm	61024620
14810412	PH4	300mm	61024625

SLOTTED SCREWDRIVERS



- SNCM + V alloy steel shank
- Polypropylene + thermoplastic rubber (TPR) grip
- Chrome plated finish with black tip
- Round shank
- DIN ISO 2380



Item Code	Tip Width	Tip Thickness	Shank Length	Bishops Code
14220303	3mm	0.5mm	75mm	61024020
14220404	4mm	0.8mm	100mm	61024040
14220503	5mm	0.8mm	75mm	61024050
14220504	5mm	0.8mm	100mm	61024055
14220512	5mm	0.8mm	300mm	61024058
14225503	5.5mm	1mm	75mm	61024060
14225504	5.5mm	1mm	100mm	61024080
14225505	5.5mm	1mm	125mm	61024090
14225506	5.5mm	1mm	150mm	61024100
14226514	6.5mm	1.2mm	38mm	61024120
14226504	6.5mm	1.2mm	100mm	61024140
14226506	6.5mm	1.2mm	150mm	61024160
14226512	6.5mm	1.2mm	300mm	61024170
14220806	8mm	1.2mm	150mm	61024180
14220807	8mm	1.2mm	175mm	61024200
14220808	8mm	1.2mm	200mm	61024220

PHILLIPS TANG-THRU SCREWDRIVERS



- SNCM + V alloy steel shank
- Polypropylene and thermoplastic rubber (TPR) handle grip
- Chrome plated finish with black tips
- Hex shank
- DIN ISO 8764



Item Code	Size	Shank Length	Bishops Code
14610103	PH1	75mm	61024860
14610204	PH2	100mm	61024870
14610306	PH3	150mm	61024880

SLOTTED TANG-THRU SCREWDRIVERS



- SNCM + V alloy steel shank
- Polypropylene and thermoplastic rubber (TPR) handle grip
- Chrome plated finish with black tip
- Hex shank
- DIN ISO 2380



Item Code	Tip Width	Tip Thickness	Shank Length	Bishops Code
14625504	5.5mm	1mm	100mm	61024810
14626504	6.5mm	1.2mm	100mm	61024815
14626506	6.5mm	1.2mm	150mm	61024820
14620807	8mm	1.2mm	175mm	61024830

1,000V INSULATED PHILLIPS SCREWDRIVERS



- SNCM + V alloy steel shank
- Polypropylene and thermoplastic rubber (TPR) handle grip
- Chrome plated finish with black tip
- Round shank
- IEC 60900:2004



Item Code	Size	Shank Length	Bishops Code
14710003	PH0	75mm	61024940
14710104	PH1	100mm	61024945
14710204	PH2	100mm	61024950
14710306	PH3	150mm	61024955

1,000V INSULATED SLOTTED SCREWDRIVERS



- SNCM + V alloy steel shank
- Polypropylene + thermoplastic rubber (TPR) grip
- Chrome plated with black tip finishing
- Round shank
- IEC 60900:2004



Item Code	Tip Width	Tip Thickness	Shank Length	Bishops Code
14720303	3mm	0.5mm	75mm	61024905
14720404	4mm	0.8mm	100mm	61024910
14725505	5.5mm	1.0mm	125mm	61024920
14726506	6.5mm	1.2mm	150mm	61024925
14720807	8mm	1.2mm	175mm	61024930

1,000V INSULATED POZIDRIV SCREWDRIVERS



- SNCM + V alloy steel shank
- Polypropylene and thermoplastic rubber (TPR) handle grip
- Chrome plated finish with black tip
- Round shank
- IEC 60900:2004



Item Code	Size	Shank Length	Bishops Code
14780003	PH0	75mm	61024970
14780104	PH1	100mm	61024975
14780204	PH2	100mm	61024980
14780306	PH3	150mm	61024985

6 PIECE FOLDING DRIVER HEX KEY SET



- Aluminium
- Folding design suitable for use on bikes
- Includes:**
- 4 x Hex keys – 3, 4, 5 & 6mm
- 1 x Phillips screwdriver – PH2
- 1 x Slotted screwdriver – 5mm



Item Code	Bishops Code
20306PR	64810530

7 PIECE FOLDING HEX KEY SET



- Aluminium
- Folding design suitable for use on bikes
- Includes:**
- 7 x hex keys – 1.5, 2, 2.5, 3, 4, 5 & 6mm



Item Code	Bishops Code
20317MR	64810518

SHORT ARM HEX KEYS – METRIC



- SNCM – V alloy steel
- Chrome plated finish



Item Code	Size	Bishops Code	Item Code	Size	Bishops Code
114515MR	1.5mm	64830015	114506MR	6mm	64830060
114502MR	2mm	64830020	114508MR	8mm	64830080
114525MR	2.5mm	64830025	114510MR	10mm	64830100
114503MR	3mm	64830030	114512MR	12mm	64830120
114504MR	4mm	64830040	114514MR	14mm	64830140
114505MR	5mm	64830050	114517MR	17mm	64830170
114555MR	5.5mm	64830055	114519MR	19mm	64830190

SHORT ARM HEX KEYS – IMPERIAL

- SNCM – V alloy steel
- Chrome plated finish



Size	Bishops Code	Size	Bishops Code	Size	Bishops Code
3/32"	64820093	1/4"	64820225	5/16"	64820625
1/8"	64820125	5/16"	64820312	3/4"	64820750
9/64"	64820140	3/8"	64820375	7/8"	64820875
5/32"	64820156	7/16"	64820437	1"	64821000
3/16"	64820187	1/2"	64820500	-	-
7/32"	64820218	9/16"	64820562	-	-

LONG ARM HEX KEYS – IMPERIAL



- SNCM – V alloy steel
- Chrome plated finish



Item Code	Size	Bishops Code	Item Code	Size	Bishops Code
112504SR	1/8"	64840125	112510SR	5/16"	64840312
112505SR	5/32"	64840156	112512SR	3/8"	64840375
112506SR	3/16"	64840187	112516SR	1/2"	64840500
112508SR	1/4"	64840225	112518SR	9/16"	64840562

8 PIECE FOLDING HEX KEY SET



- SNCM + V alloy steel
- Finishing: chrome plated
- Weight: 0.33kg
- Includes:**
- 8 x hex keys – 2, 2.5, 3, 4, 5, 6, 8 & 10mm



Item Code	Bishops Code
20218MR	64810520

9 PIECE EXTRA LONG HEX KEY SET



- SNCM + V alloy steel
- Chrome plated finishing
- Weight: 0.44kg
- Includes:**
- 9 x hex keys – 1.5, 2, 2.5, 3, 4, 5, 6, 8 & 10mm



Item Code	Bishops Code
20209MR	64810110

GET MORE AT BISHOPS



MAGNETIC PARTS TRAY

Page 162



HEX BALL, SPLINE & STAR KEYS

HAND & CUTTING TOOLS

7 PIECE BALL HEX KEY SET – METRIC

- Long arm
- SNCM + V alloy steel
- Chrome plate finishing
- Weight: 0.37kg
- Includes:**
- 7 x ball hex keys – 2.5, 3, 4, 5, 6, 8 & 10mm



Item Code
20107MR01

Bishops Code
64810220

7 PIECE BALL HEX KEY SET – IMPERIAL

- Extra long arm
- SNCM + V alloy steel
- Chrome plate finishing
- Weight: 0.36kg
- Includes:**
- 7 x ball hex keys – 3/32", 1/8", 5/32", 3/16", 1/4", 5/16" & 3/8"



Item Code
20107SR

Bishops Code
64810210

8 PIECE FOLDING BALL HEX KEY SET – METRIC

- Chrome-vanadium steel
- Ball end
- Includes:**
- 8 x Hex keys – 1.5, 2, 2.5, 3, 4, 5, 6 & 8mm



Item Code
W022004

Bishops Code
63521047

9 PIECE BALL HEX KEY SET – METRIC

- Extra long arm
- SNCM + V alloy steel
- Chrome plate finishing
- Weight: 0.44kg
- Includes:**
- 9 x ball hex keys – 1.5, 2, 2.5, 3, 4, 5, 6, 8 & 10mm



Item Code
20109MR

Bishops Code
64810240

5 PIECE SPLINE L-WRENCH SET

- Extra long
- L-type
- Includes:**
- 5 x Spline L-wrenches – 5, 6, 8, 10 & 12mm



Item Code
20515PR

Bishops Code
64815850

9 PIECE STAR L-WRENCH SET

- SNCM + V alloy steel
- Chrome plated finishing
- Weight: 0.3kg
- Includes:**
- 9 x star L-wrenches – T10, T15, T20, T25, T27, T30, T40, T45 & T50



Item Code
20309PR

Bishops Code
64815720

7 PIECE TAMPER RESISTANT STAR L-WRENCH SET

- SNCM + V alloy steel
- Chrome plated finishing
- Weight: 0.13kg
- Includes:**
- 7 x Star L-wrenches – T10, T15, T20, T25, T27, T30 & T40



Item Code
20407PR

Bishops Code
64815750

8 PIECE TORX KEY SET

- Chrome vanadium
- Light and strong aluminium structure handle
- Includes:**
- 8 x Torx keys – T8, T10, T15, T20, T25, T27, T30 & T40



Item Code	Bishops Code
W022019	63521051

9 PIECE LONG ARM TORX KEY SET



- SNCM – V alloy steel
- Chrome plated finish
- Includes:**
- 9 x Torx (star) wrenches – T10, T15, T20, T25, T27, T30, T40, T45 & T50



Item Code	Bishops Code
20319PR	64815722

9 PIECE TAMPER RESISTANT LONG ARM TORX KEY SET



- Extra long arm
- Double length with extra leverage
- SNCM – V alloy steel
- Chrome plated finish
- Includes:**
- 9 x Torx (star) wrenches – T10H, T15H, T20H, T25H, T27H, T30H, T40H, T45H & T50H



Item Code	Bishops Code
20419PR	64815752

BALL HEX KEY WRENCHES



- Hexagon with ball point head
- SNCM + V alloy steel
- Chrome plated with black tip finishing



Item Code	Size	Length	Bishops Code	Item Code	Size	Length	Bishops Code
116002M	2mm	150mm	64880020	116005M	5mm	215mm	64880050
116025M	2.5mm	150mm	64880025	116006M	6mm	215mm	64880060
116003M	3mm	150mm	64880030	116008M	8mm	280mm	64880080
116004M	4mm	150mm	64880040	116010M	10mm	280mm	64880100

TAMPER RESISTANT TORX HEX KEY WRENCHES



- For Torx internal screw
- Tamper resistant type
- Hexagon with ball point head
- SNCM + V alloy steel
- Chrome plated with black tip finishing



Item Code	Size	Length	Bishops Code	Item Code	Size	Length	Bishops Code
116310R	T10	150mm	64890010	116330R	T30	215mm	64890030
116315R	T15	150mm	64890015	116340R	T40	215mm	64890040
116320R	T20	150mm	64890020	116345R	T45	280mm	64890045
116325R	T25	150mm	64890025	116350R	T50	280mm	64890050
116327R	T27	215mm	64890027	-	-	-	-

8 PIECE BALL HEX KEY WRENCH SET



- SNCM - V alloy steel
- Chrome plated finish with black tip
- Includes:**
- Sizes: 2, 2.5, 3, 4, 5, 6, 7, 8 & 10mm



Item Code	Bishops Code
22108MR	64810320

9 PIECE TORX HEX KEY WRENCH SET



- SNCM + V alloy steel
- Chrome plated finishing with black tip
- Weight: 1kg
- Includes:**
- 9 x Torx wrenches –T10, T15, T20, T25, T27, T30, T40, T45 & T50



Item Code	Bishops Code
21309PR	64815820



POWER BITS

HAND & CUTTING TOOLS

DRILL CHUCK ARBORS

- Jacobs taper arbors and taper shank arbors (DIN 238) for precision grinding
- Drill chuck arbors are used to mount a drill chuck or any other tool which has a female taper shank onto a machine which has a female taper shank socket in its workhead
- Manufactured from selected case hardened hi-tensile steel (20 MnCr5/SAE8620)
- Case hardened 54-58 HRC for increased resistance to wear



Item Code	Description	Size	Bishops Code
G/16/M2	Taper Shank Arbor, DIN 238	2MT x B16	76020018
GAT/23	Jacobs Taper Arbor	2MT x JT3	76020015
GAT/26	Jacobs Taper Arbor	2MT x JT6	76020010
GAT/33	Jacobs Taper Arbor	3MT x JT3	76020020
GAT/36	Jacobs Taper Arbor	3MT x JT6	76020030

SQUARE HEAD 1/4" HEX SHANK DRIVER



- Silicon chrome vanadium alloy steel (S2)
- Anti-rust oiled, sand-blasted
- Length: 25mm



Item Code	Size	Bishops Code
102501R	PH1	76030530
102503R	PH3	76030536

PHILLIPS HEAD 5/16" HEX SHANK DRIVER



- Silicon chrome vanadium alloy steel (S2)
- Anti-rust oiled, sand-blasted
- DIN 2251-2
- Length: 36mm



Item Code	Size	Bishops Code
183602P	PH2	61006120
183603P	PH3	61006140

SLOTTED HEAD 1/4" HEX SHANK DRIVERS



- Silicon chrome vanadium alloy steel (S2)
- Anti-rust oiled, sand-blasted
- DIN ISO 2351-1
- Length: 25mm



Item Code	Tip Size	Tip Thickness	Bishops Code
102504S1	4mm	0.5mm	76030205
102555S1	5.5mm	0.8mm	76030240

SLOTTED HEAD 5/16" HEX SHANK DRIVER



- Silicon chrome vanadium alloy steel (S2)
- Anti-rust oiled, sand-blasted
- DIN 2351-1
- Length: 36mm



Item Code	Tip Width	Tip Thickness	Bishops Code
183609S	9mm	1.6mm	61006160
183611S	11mm	2mm	61006180

HEX HEAD 1/4" HEX SHANK DRIVERS



- Silicon chrome vanadium alloy steel (S2)
- Anti-rust oiled, sand-blasted
- DIN ISO 2351-3
- Length: 25mm



Item Code	Size	Bishops Code
102504H	4mm	76030498
102505H	5mm	76030500
102506H	6mm	76030502

GET MORE AT BISHOPS

PHILLIPS & SLOTTED SCREWDRIVERS

From Page 232



TORX 1/4" HEX SHANK DRIVER

- Silicon chrome vanadium alloy steel (S2)
- Anti-rust oiled, sand-blasted
- Length: 25mm



Item Code	Size	Bishops Code
102508T	T8	76030550
102510T	T10	76030552
102515T	T15	76030554
102520T	T20	76030556
102530T	T30	76030560

POZIDRIV TYPE 1/4" HEX SHANK DRIVER

- Silicon chrome vanadium alloy steel (S2)
- Anti-rust oiled, sand-blasted
- DIN ISO 2351-2
- Length: 25mm



Item Code	Size	Bishops Code
102502Z	PH2	76030415
102503Z	PH3	76030460

PHILLIPS POWER BITS

- Silicon chrome vanadium alloy steel (S2)
- Anti-rust oiled, sand-blasted
- DIN ISO 2351-2

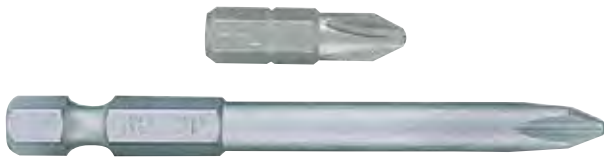

Item Code	Size	Length	Bishops Code
134501P	PH1	45mm	76030305
102502P	PH2	45mm	76030325
717002P	PH2	70mm	76030345
102503P	PH3	25mm	76030377

DOUBLE ENDED PHILLIPS POWER BITS

- Silicon chrome vanadium alloy steel (S2)
- Nickel plated
- Long head type



Item Code	Size	Length	Bishops Code
134502P	PH2	45mm	76030360
136502P	PH2	65mm	76030365



32 PIECE BIT SET

- Silicon chrome vanadium alloy steel (S2)
- Anti-rust oiled, sand-blasted
- Plastic case size: 120(l) x 70(w) x 42(h)mm
- Weight: 0.3kg

Includes:

- 4 x 1/4" Hex size shank drivers (hexagon head) – H3, H4, H5 & H6
- 3 x 1/4" Hex size shank drivers (Phillips head) – PH1, PH2 x 2 & PH3
- 4 x 1/4" Hex size shank drivers (slotted head) – 3, 4, 5 & 6mm
- 7 x 1/4" Hex size shank drivers (for Torx internal) – T10, T15, T20, T25, T27, T30 & T40
- 7 x 1/4" Hex size shank drivers (for Torx head) – T10, T15, T20, T25, T27, T30 & T40
- 3 x 1/4" Hex size shank drivers (Pozidriv type) – PZ1, PZ2 x 2 & PZ3
- 1 x Magnetic bit holder with Q.R. sleeve
- 1 x Bit adaptor



Item Code	Bishops Code
1032CQ	76030703

49 PIECE BIT SET

- Silicon chrome vanadium alloy steel (S2)
- Anti-rust oiled, sand-blasted
- Weight: 0.51kg

Includes:

- 8 x 1/4" Hex size shank drivers (hexagon head) – H2, H2.5, H3, H4, H5, H6, H7 & H8
- 8 x 1/4" Hex size shank drivers (Phillips head) – PH1, PH2 (6mm), PH2 (4.7mm) & PH3 (2 of each size)
- 6 x 1/4" Hex size shank drivers (slotted head) – 4 x 0.5, 5.5 x 0.8 & 6.5 x 1.2mm (2 of each size)
- 8 x 1/4" Hex size shank drivers (Torx head) – T9, T10, T15, T20, T25, T27, T30 & T40
- 8 x 1/4" Hex size shank drivers (Torx tamper resistant head) – T9H, T10H, T15H, T20H, T25H, T27H, T30H & T40H
- 6 x 1/4" Hex size shank drivers (Pozidriv type) – PZ1, PZ2 & PZ3 (2 of each size)
- 2 x 1/4" Hex size shank drivers (square head) – RB1 & RB2
- 1 x 1/4" Drive bit holder
- 1 x Magnetic bit holder
- 1 x 1/4" Socket adaptor – 25mm



Item Code	Bishops Code
1049CQ	76030704



NUTSETTERS

- Chrome vanadium alloy steel
- Anti-rust oiled, sand-blasted
- Magnetic type
- DIN 3126



Item Code	Size	Length	Bishops Code
7616508S	1/4"	65mm	76030610
7614210S	5/16"	42mm	76030620
7616510S	5/16"	65mm	76030630
7616512S	3/8"	65mm	76030650



RIVETERS & STAPLE GUNS

HAND & CUTTING TOOLS

RIVETER SET

- Drop-forged aluminium body
- Capacity: Ø4.8mm
- Case size: 276(l) x 160(w) x 46(h)mm
- Weight: 1.06kg

Includes:

- 1 x 21-20-101 Rivet gun
- 20 x Various rivets – 4.8 x 10mm, 4.8 x 8mm, 4 x 10mm & 4 x 8mm



Item Code	Bishops Code
21-20-07MR	63560320

RIVET GUN

- Drop-forged aluminium body
- Capacity: Ø4.8mm
- Nosepiece: 5/32" (Ø2.4mm), 1/8" (Ø3.2mm), 3/32" (Ø4.0mm) & 3/16" (Ø4.8mm)
- Length: 260mm
- Weight: 0.588kg



Item Code	Bishops Code
21-20-101	63560520

HEAVY DUTY RIVET GUN

- Drop-forged aluminium body
- Capacity: Ø6.4mm
- Nosepiece: 1/8" (Ø3.2mm), 3/32" (Ø4.0mm), 3/16" (Ø4.8mm) & 1/4" (Ø6.4mm)
- Length: 460mm
- Weight: 1.48kg

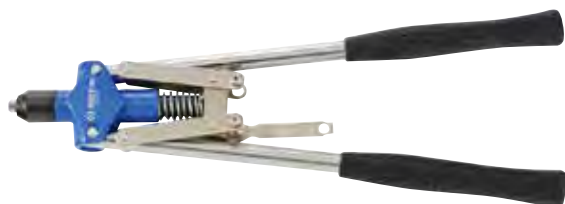

Item Code	Bishops Code
79711	63560540

EXPANDABLE RIVET GUN

- Expandable framework design to press riveter
- Heavy duty riveter for stainless or aluminium rivets
- Length: 315–870mm

Includes:

- 4 x Interchangeable nozzles – 3.2, 4, 4.8 & 6.4mm



Item Code	Bishops Code
79721	63560325

LAZY TONG HAND RIVETER

- Heavy duty riveter suited to vehicle maintenance, construction and agriculture applications
- Aluminium die cast body is strong and lightweight
- Steel levers are riveted not bolted
- The jaws are fully hardened and non-wearing

Includes:

- 5 hardened and replaceable nose bushes – 2.4mm (5/32"), 3.2mm (1/8"), 4mm (3/32"), 4.8mm (3/16") & 6.4mm (1/4")

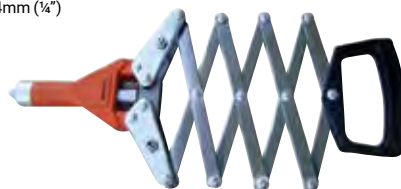

Item Code	Bishops Code
LT-6	63560580

STAPLE GUN

- Chrome plated steel construction
- Quick and easy staple loading
- Handle lock
- Suitable for large stapling jobs around the home or office
- Suits TRA700 and Arrow T50 staples from 1/4" to 3/16"



Item Code	Bishops Code
TR110	60080550

ALUMINIUM STAPLE GUN

- Aluminium housing
- Heavy duty gun with deep penetration
- Easy-squeeze handle and anti-jam mechanism
- High visibility colour



Item Code	Bishops Code
TR150	60080555

HEAVY DUTY STAPLES

- For heavy duty stapling jobs
- Suitable for heavy duty staple guns
- Narrow crown
- 1,000 per pack



Item Code	Size	Bishops Code
TRA705T	8mm (5/16")	60080575
TRA706T	10mm (3/8")	60080580
TRA708T	12mm (1/2")	60080585
TRA709T	14mm (9/16")	60080590

ROUND MOUTH SHOVELS

BLACK  JACK

- Carbon steel blade
- Suitable for agricultural, horticultural, building and construction applications



63574600



63574020



63574605

Description	Length	Blade Size	Bishops Code
Wooden Handle	1,510mm	290 x 320mm	63574600
Wooden Handle with D-Handle	995mm	210 x 280mm	63574020
Fibreglass Handle	1,510mm	285 x 180mm	63574605

SQUARE MOUTH SHOVELS

BLACK  JACK

- Carbon steel blade
- Ideal for soil, sand and other garden materials



63574540



63574580



63574585

Description	Length	Blade Size	Bishops Code
Wooden Handle with D-Handle	1,030mm	300 x 220mm	63574540
Wooden Handle	1,530mm	280 x 210mm	63574580
Fibreglass Handle with Plastic Coated Grip	1,455mm	315 x 256mm	63574585

SQUARE MOUTH SHOVEL



- Fibreglass handle
- Size: 195 x 270 x 1,500mm



Item Code	Bishops Code
S525-5FL	63574590

METAL DRAINAGE SHOVEL

BLACK  JACK

- Wooden handle
- Carbon steel blade
- D-shape grip
- Sharp square edges produce clean dug walls and minimise disruption of the surrounding soil
- Length: 1,130mm
- Blade dimensions: 135 x 300mm



Item Code	Bishops Code
S526-1WD	63574080

FAN GARDEN RAKE

- Plastic rake for a wide range of gardening and landscaping jobs
- Ideal for raking litter, leaves, sand and lawn clippings
- Great for top dressing
- Wooden handle
- Head size: 450mm



Item Code	Bishops Code
180-71-07146	63534750

GET MORE AT BISHOPS 

WHEELBARROWS

Page 316



GRASS TRIMMERS

Page 154





TELESCOPIC INSPECTION MIRROR

- Round mirror fitted with pocket clip
- Mirror diameter: 32mm
- Length range: 165–450mm

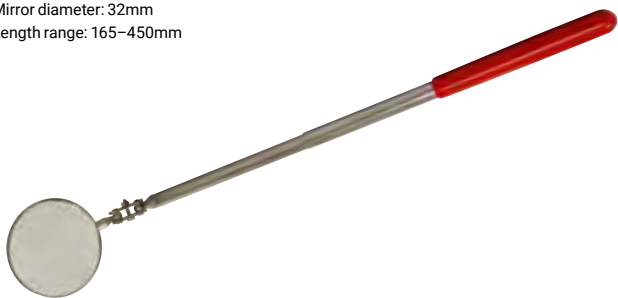

	Bishops Code
	62080140

LARGE TELESCOPIC INSPECTION MIRROR

- Ball joint head swivels to any position
- Mirror diameter: 57mm
- Length range: 254–356mm



Item Code	Bishops Code
SCMT70188	62080150

CLAW TYPE PICKUP TOOL

- Red plastic grip with metal coil spring
- Four pronged claw
- Ideal for picking up objects from hard-to-reach places
- Length: 600mm

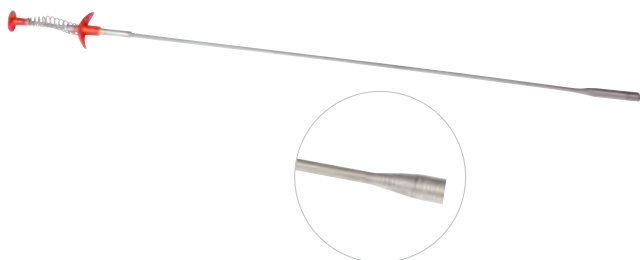

	Bishops Code
	62080210

MAGNETIC PICKUP TOOLS



- Compact and ergonomic design for comfortable holding
- Enhanced flexible conduit for perfect shaping
- Solid crimping for holding tube and flexible conduit
- More powerful magnetising force
- Comfortable pushing strength
- 0.5kg magnetic power



Item Code	Length	Bishops Code
2121-12	305mm	62080230
2124-18	455mm	62080240

5 PIECE SCRIBER PICK & HOOK SET

- Includes:
- 4 x Scribers
- 1 x Magnetic handle
- Vinyl pouch



Item Code	Bishops Code
SCMT70265	63060800

4 PIECE HOOK & PICK SET



- For scribing, alignment, installing or removing O-rings, seals and washers
- Tray category #7 to suit King Tony chests and trolleys
- Tray size: 280(l) x 187(w)mm
- Tool length: 260mm (10")

- Includes:
- 1 x Bent pick
- 1 x 90° pick
- 1 x Hook
- 1 x Straight pick



Item Code	Bishops Code
9-30904AY	63060110

150MM BEARING SCRAPERS



- Designed for removing high spots on machined metal to create a smooth and even surface on slideways, bearings, cast iron surface plates and precision marking out plates
- Manufactured from selected steel and lightly tempered and hardened to 55–60HRc
- Comes with a round wooden handle for comfortable grip
- Ideal for small engineering jobs
- Length: 150mm



Item Code	Description	Bishops Code
ES/HR/6	Half Round	63006020
ES/F/6	Flat	63006040
ES/T/6	Triangular	63006060

GET MORE AT BISHOPS



SCRIBERS

Page 249

STAINLESS STEEL RULERS

- Imperial and metric combined rules
- Stainless steel with polished finish and permanently engraved clear to read graduations
- Graduated in metric dimensions on one edge and imperial on the other
- Reverse side of the rule has a permanently engraved metric to imperial conversion table
- One square end and one rounded end with hanging hole

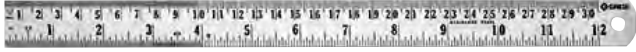

Item Code	Length	Bishops Code
SR/6	150mm (6")	60020115
SR/12	300mm (12")	60020120
SR/24	600mm (24")	60020030
SR/40	1,000mm (40")	60020040

FOLDING PLASTIC RULER

- Highly durable engineering plastic
- Metric/imperial measurements
- Foldable for convenient storage and portability
- One straight and one bevelled edge
- Length: 1m (3ft)



Item Code	Bishops Code
35-445	60020110

TAPE MEASURES

- Metric and imperial measurements
- Super compact
- High quality
- Stainless steel blade
- Belt clip for convenience
- Rubber grip for more comfortable use



Length	Blade Width	Bishops Code
3m	16mm	60080828
5m	19mm	60080830
8m	15mm	60080845
10m	32mm	60080870

HI-VIS TAPE MEASURES

- Metric measurements
- Compact, high quality
- Hi-vis orange for extra visibility



Item Code	Length	Blade Width	Bishops Code
TM5MPRE	5m	19mm	60080180
TM8MPRE	8m	25mm	60080190
TM10MPRE	10m	25mm	60080192

OPEN REEL STEEL TAPE MEASURE

- High impact ABS case
- Metric graduations
- Ideal for high precision professional jobs
- Acrylic coated carbon steel blade
- Easy-to-read bold numbers
- Length: 50m



Bishops Code
60080330

OPEN REEL FIBREGLASS TAPE MEASURE

- ABS open reel case
- Metric and imperial graduations
- Ideal for contractors and surveyors, easy to clean and safe from electrical hazards
- Has a high level of longitudinal strength and tensile strength
- Can withstand pulling force of over 200kg
- Case is fitted with an easy-grip winder
- Easy-to-read bold numbers
- Protruding marker at the bottom of the case
- Length: 50m (165ft)



Bishops Code
60080325

OPEN REEL FIBREGLASS TAPE MEASURE

- ABS open reel case
- Metric and imperial graduations
- Ideal for contractors and surveyors
- Easy to clean and safe from electrical hazards
- Has a high level of longitudinal strength and tensile strength
- Fitted with an easy-grip winder
- Easy-to-read bold numbers
- Length: 100m (330ft)



Item Code	Bishops Code
190-81-07493	60080340

OPEN REEL FIBREGLASS TAPE MEASURE

- Metric graduations
- PVC coated blade can be wound up and is easily cleaned
- Easy to read markings
- Rubber grip for comfort
- Hi-vis yellow
- Length: 60m
- Blade width: 12mm



Item Code	Bishops Code
2-34-795	60080525



DIPPING TAPE MEASURE, SPIRIT & ANGLE LEVELS & PLUMB BOB

HAND & CUTTING TOOLS

DIPPING TAPE MEASURE

- 0.25mm thick carbon steel blade
- Easy to read markings against black etched background
- Wooden handle for carrying
- Comes complete with weight set
- Length: 10m



Item Code	Bishops Code
34-273	60080920

MAGNETIC TORPEDO SPIRIT LEVEL

- Fitted with 3 anti-shock vials
- Accuracy: 1mm/m
- Length: 220mm
- Weight: 110g



Item Code	Bishops Code
65158	60010060

MAGNETIC TORPEDO SPIRIT LEVEL

- Aluminium frame
- Magnetic groove base
- Rubber end caps for shock protection
- 3 easy to read vials
- Length: 225mm (9")



Item Code	Bishops Code
W062003	63521116

MAGNETIC TORPEDO SPIRIT LEVEL

- 3 vials
- Magnetic base for metal surfaces
- Shock resistant rubber end casings
- Pipe groove for working on rounded surfaces
- Length: 228mm



Item Code	Bishops Code
43-511	60010040

MAGNETIC SPIRIT LEVEL



- Aluminium
- Fitted with 3 anti-shock vials
- Accuracy: 1mm/m



Item Code	Length	Weight	Bishops Code
651452	400mm	230g	60010210
651472	600mm	310g	60010220
651992	1,000mm	900g	60010230
652002	1,200mm	1.00kg	60010240
65201	1,500mm	1.25kg	60010250

I-BEAM MAGNETIC SPIRIT LEVELS

- Aluminium frame
- Rubber end caps for shock protection
- Impact resistant bubble vials
- Magnetic base



63521121

Item Code	Length	Bishops Code
W062009	610mm (24")	63521119
W062010	1,220mm (48")	63521121

GAM 220 MF PROFESSIONAL ANGLE MEASURER



- Automatic calculation of single and double mitre angles
- Memory function allows for rapid calculation and transfer of frequently used angle dimensions
- Arm extension for measuring in hard-to-reach areas
- Automatic deactivation after approx. 3 mins
- Measurement range: 0–220°
- Measurement accuracy of angles: $\pm 0.1^\circ$
- Measurement accuracy of vials: $\pm 0.05^\circ$
- Staple length: 400mm
- Weight: 1.1kg
- Includes:
 - 4 x AA batteries



Item Code	Bishops Code
0.601.076.600	60010970

PLUMB BOB

- Solid brass construction
- Replaceable hardened steel tip
- Screw top for easily attaching string to the centre
- Size: 8oz



Item Code	Bishops Code
47-973	62552120

LASER MEASURING TOOLS

A laser measuring tool sends a pulse of laser light to the target and measures the time it takes for the reflection to return. This method provides fantastic accuracy, efficiency and safety. Most varieties have the ability to level, calculate lengths, areas and volumes and triangulate.

Range

The range is the maximum distance in which the laser can provide an accurate measure. If you work outdoors, you will want to look for a laser measuring tool with a high range. Some variations can be accurate up to 600m.

Plumb Line

The plumb line is a beam that shoots vertically upwards and/or downwards from the laser measuring tool. This beam is a 90° reference and assists in the creation of a square layout.

Surface

A surface laser projects two lasers that cross at a 90° angle. Suitable for tilers, it assists in the checking of floor planarity. Many of these lasers also include a 45° laser for fast and precise aligning.

Volume

Many laser measuring tools have on-board functions that allow the calculation of volume by taking into account the height, length and width of an area.

Find out how laser measuring tools can save time in your workplace by contacting Bishops today.

Measurements:



RANGE



AREA

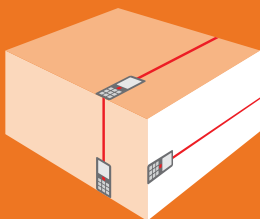

VOLUME

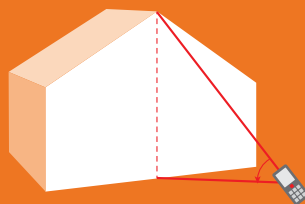

INDIRECT

GLM 100-25 C LASER RANGEFINDER – 100M



- Precise laser measure for easy indoor and outdoor measuring and documenting
- Accurate, 100m laser measuring thanks to digital camera viewfinder with zoom function
- Large, high-contrast IPS colour display with flip
- Connects via Bluetooth for efficient data documentation
- Area, volume, indirect, continuous, tilt, digital bubble level, trapezium, tripod thread, IP54



Item Code	Bishops Code
0.601.072.YK0	60010920

GLM 150 C LASER RANGEFINDER – 150M



- The Bosch Professional GLM 150 C Distance Measurer is an excellent tool for outdoor measurement up to 150m range with its camera viewfinder
- x3 digital zoom and an accuracy of 0.15 mm/m
- See your measurements at ease with its big 2.8" colour display
- Able to calculate the following; area, volume, indirect, double indirect and trapeziums
- Continuous measurements
- Stakeout feature
- Memory of the last 30 measurements
- 360° tilt and digital bubble level
- IP54 dust and splash protection rated
- Bluetooth compatible with the free Bosch Measuring Master app for data transfer and management
- Protective pouch included



Item Code	Bishops Code
0.601.072.FK0	60010930

GLL 3X 15M LASER LINE



- Compact 3-line laser, a versatile solution for indoor jobs
- Compact, modern and robust design for great mobility and durability
- Easy to use for versatile applications
- Vivid line visibility for maximum work efficiency
- Working range: 15m
- Laser diode: 635nm, <1mW
- Laser class: 2
- Accuracy: ± 0.5 mm/m
- Self-levelling range: ± 4°
- Accepts 4 x AA batteries
- Weight: 0.5kg



Item Code	Bishops Code
0.601.063.CJ0	60010925



GOL 26D OPTICAL LEVEL

- Designed for outdoor use due to sturdy metal housing with dust and splash protection (IP54)
- Robust design with built-in target collimator and integrated circular vial
- Compensator lock for safe transport
- 360° measurement
- Magnification: 26x
- Accuracy: ±1.6 mm at 30m
- Working range: 100m
- Operating temperature: -10 to 50°C
- Storage temperature: -20 to 70°C
- Weight: 1.5kg



Item Code	Bishops Code
0.601.068.000	60010983

BT 170 HD BUILDING TRIPOD

- Absolutely secure stance on any floor
- Heavy aluminium construction with double banded legs for higher stability
- Optimised working with line, point, rotation laser level and optical level
- Locking clamps for quick adjustment of height and fast disassembling
- Shoulder strap for easy transportation
- Removable rubber base provides protection of indoor floor surfaces
- Work height: 107–165cm
- Weight: 5.5kg



Item Code	Bishops Code
0.601.091.B00	60010985

D-TECT 120 UNIVERSAL DETECTOR

- Detection materials: Metal, AC, wood, live wires, PVC
- Max. detection depth: 120mm
- Dual power source compatible with 10.8V Li-ion battery pack or AA cell battery
- Intuitive use and easily comprehensible results due to "traffic light" LED warning
- Requires no calibration
- Battery not included



Item Code	Bishops Code
0.601.081.3K0	60010940

WIFI BORESCOPE

- WiFi BoreScope transmits and displays video and images directly to your smartphone up to 9m away
- Waterproof 9mm camera has 6 on-board, adjustable LED lights and outputs high-quality 640 x 480 images
- Tough, armoured 1.8m long waterproof camera gooseneck manoeuvres around obstacles while maintaining rigidity
- Battery status indicator tracks the charge level of the lithium-ion battery
- Increase and decrease camera LED output either on the BoreScope or in the App
- The App not only acts as a display, but stores and shares images and videos via text or email
- IP rating: Camera/cable: IP67; Body: IP42
- 3m drop test safety rating

Includes:

- Pocket clip, USB charging cable, hook attachment, carrying case and instructions



Item Code	Bishops Code
ET20	64530400

STANLEY DIGITAL PHOTO TACHOMETER

- Non-contact rpm measurement of moving components
- LED detection beam
- 5 digit LCD display
- Automatic data hold function
- Low battery indicator
- Includes 3 pack reflective tape
- Detection range: 50–500mm (using reflective tape)



Item Code	Bishops Code
SCMT70934	62080120

FLUKE MINI INFRARED THERMOMETER

- Highly accurate
- 10:1 distance to spot ratio
- Single laser targeting
- IP54 rating
- Powered by two AA batteries
- Temperature range: -30°C to 500°C
- Accuracy: ±1.5%
- Dimensions: 175 x 85 x 75mm
- Weight: 255g



Item Code	Bishops Code
FLU62MAX	70530048

DUAL LASER INFRARED THERMOMETER



- Optical resolution (distance-to-spot): 12:1
- Features include dual-laser targeting; auto-scan; max/min/avg/diff; high/low alarm; back-lit display; auto switch-off
- Drop protection: 2m
- Measurement range: -30° to 400° C
- Uses one 9V battery, with battery life expectancy at 10 hours of continuous use with laser and back light on
- Includes customised pouch and batteries
- Adjustable emissivity
- Soft-touch, over-mould housing



Item Code	Bishops Code
A-IR5	64530410

INFRARED THERMOMETER WITH LASER POINTER



- Test the temperature without contacting the object
- IR Point can be displayed clearly
- °C and °F interchangeable functions
- Dark screen backlight test board functions
- Temperature range: -30°C to 550°C (-22 to 1,022°F)
- Resolution: 0.1°C (0.1°F)
- Accuracy: ±2.5% (3°C)
- Emissivity: selectable (0.85/0.90/0.95)
- Distance to spot ratio: 12:1
- Auto power off: 15 seconds
- Laser pointer: class 2 laser < 1mW
- Comes with 1 x 9V battery



Item Code	Bishops Code
9DN12	64530420

PLASTIC VERNIER CALIPER

- Plastic construction
- Measures both inside and outside
- Range: 0–150mm



Item Code	Bishops Code
4825013	60280005

VERNIER CALIPERS

- Made from hardened stainless steel
- Can measure inside/outside diameters, depth and steps
- Parallax-free bevel
- Easy to use basic design
- Clear markings for easy reading
- Locking screw
- Graduation: 0.02mm
- Includes storage case



Size	Bishops Code
150mm	60280010
200mm	60280020
300mm	60280030

VERNIER CALIPERS

- Made from stainless steel and hardened for longer life
- Extra long scale for easier use
- Can take inside, outside, depth and step measurements
- Conversion table on back



Item Code	Graduations	Accuracy	Length	Bishops Code
VC/6C	0.02mm	±0.02mm	153mm	60280510
VC/8C	0.02mm	±0.03mm	204mm	60280520
VC/12C	0.02mm	±0.04mm	305mm	60280530

DIAL CALIPERS

- Metal construction
- Shockproof
- Measures both inside and outside
- Also measures depth/step



60280120

Description	Graduation	Range	Bishops Code
Metric	0.02mm	0–150mm	60280110
Metric	0.02mm	0–200mm	60280120
Imperial	0.001"	0–6"	60280130

DIGITAL VERNIER CALIPERS



- Metric and imperial measurements as well as fractions
- All metal construction with no plastic parts



Item Code	Size	Bishops Code
EDF-6C	150mm (6")	60280270
EDF-8C	200mm (8")	60280280
EDF-12C	300mm (12")	60280290

DIGITAL VERNIER CALIPER

- Stainless steel
- Metric and imperial scale
- LCD digital display screen
- Range: 0–150mm (0–6")
- Accuracy: 0.02mm (0.001")
- Battery powered
- Auto on/off



Item Code	Bishops Code
W066002	63521124

JENNY CALIPER – FIRM JOINT



- Manufactured from selected steel, the legs are exceptionally rugged and well finished
- The leg that holds the adjustable point is offset, the locating lug is incorporated in the straight leg
- Lug provides additional support to the leg
- Used in layout work for locating and testing centres, laying off distances from an edge etc
- Working faces hardened to 58HRC
- 150mm

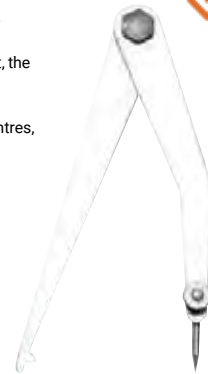

Item Code	Bishops Code
JC/6	60002220

SPRING DIVIDERS



- Used for marking on steel or transferring measurements from master templates
- Made from high grade with a polished finish steel and fitted with a spring joint for precision settings
- Fitted with quick nut adjustment
- The legs pivot on a roller and are tensioned by a bow spring
- The large bearing surface on the fulcrum stud prevents side deflection of legs
- Points of the divider are hardened 50-55HRC for increased wear resistance



Item Code	Size	Bishops Code
DD/Q/6	150mm	60002320
DD/Q/8	200mm	60002330
DD/Q/12	300mm	60002350



CALIPERS & DIVIDERS, DIAL GAUGES & STANDS

INSIDE & OUTSIDE CALIPERS – SPRING JOINT

- Designed for taking comparative measurements and transferring the dimensions to a micrometer, precision rule etc.
- Manufactured from selected steel, calipers have a spring joint for precision settings
- Fitted with quick nut adjustment
- The legs pivot on a roller and are tensioned by bow spring.
- The fulcrum stud has a large bearing surface that prevents side deflection of legs
- Divider points are hardened 50-55 HRC for increased wear resistance



Item Code	Description	Size	Bishops Code
ID/Q/6	Inside Caliper	150mm	60002020
ID/Q/8	Inside Caliper	200mm	60002030
ID/Q/10	Inside Caliper	250mm	60002040
ID/Q/12	Inside Caliper	300mm	60002050
OD/Q/6	Outside Caliper	150mm	60002120
OD/Q/8	Outside Caliper	200mm	60002130
OD/Q/10	Outside Caliper	250mm	60002140
OD/Q/12	Outside Caliper	300mm	60002150

3 PIECE CALIPER & DIVIDER SET

- Made from high grade steel with a black powder coated finish
 - Legs are machined to a smooth taper
 - Suitable for metal and woodworking
 - 150mm
- Includes:**
- 1 x Inside caliper
 - 1 x Outside caliper
 - 1 x Spring divider



Item Code	Bishops Code
CD/SP/ST-6	60002390

DIAL GAUGE

- Carbide ball point and stainless steel spindle
- Fitted with limit pins and outer frame clamp
- Range: 0.01–10mm
- Outside diameter: 57mm



Item Code	Bishops Code
DLG/P/02C	60205550

DIAL GAUGES

- Shank diameter: 55mm
- Reading: 0–100



60205050

Description	Graduation	Range	Bishops Code
Imperial	0.001"	0"–1"	60205030
Metric	0.01mm	0–10mm	60205050

MAGNETIC STAND FOR DIAL GAUGES

- Metal stand has an on/off switch for the magnet
- Fine adjust
- Reach: 300mm



Item Code	Bishops Code
	60205010

MAGNETIC BASE STAND

- Allows dial gauge to be set to any required position
- Suitable for light to medium duty applications
- Magnetic pull of up to 40kg (88lb)
- Fitted with easy to use On/Off control knob
- The stand can be used horizontally, vertically or upside down while the V step holds base to arbors, shafts and chucks
- Base dimensions: 45(l) x 48(w) x 50(h)mm
- Overall height: 245mm
- Spindle mounting thread (Female): M8 x 1.25mm

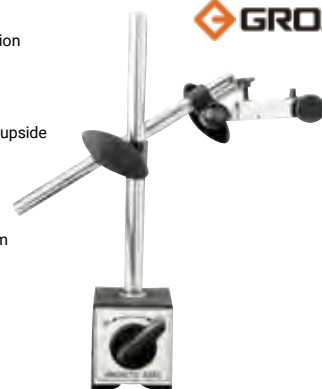

Item Code	Bishops Code
MB/25	60205015

HIGH POWER MAGNETIC BASE STAND

- Allows dial gauge to be set to any required position
- Fitted with powerful permanent magnets and can be easily situated on any ferrous surface
- Magnetic pull of up to 60kg (130lb)
- The arm has three movable joints and can be set to any desired position
- Attractive grey hammertone finish
- Chrome plated base post and holding rod
- Base dimension: 50(l) x 60(w) x 55(h)mm
- Overall height: 350mm
- Spindle mounting thread (Female): M8 x 1.25mm



Item Code	Bishops Code
MB/32F	60205020

UNIVERSAL SURFACE GAUGE

- Designed for scribing lines, transferring measurements or probing surfaces in inspection work
- Suitable for machinists and toolmakers
- Fully hardened and ground base
- V groove on the base allows the gauge to be used on curved surfaces
- Can be used as both a height and depth gauge
- Suitable for holding a dial gauge
- The tapered scriber tip is hardened to 55-60HRC
- Base dimensions: 80(l) x 63(w)mm
- Spindle length: 300mm with extra 225mm spindle
- Scriber length: 175mm



Item Code	Bishops Code
SG/9-12	60205990

INSIDE MICROMETERS

- Metric measurements
- Metal construction
- Graduation: 0.01mm
- Supplied in a wooden case



Range	Bishops Code
50-250mm	60230020
50-600mm	60230030

DIGITAL EXTERNAL MICROMETERS



- Metric and Imperial
- Carbide measuring faces
- Accuracy: 0.004mm (0.00016")



Item Code	Description	Bishops Code
EDM/1	0-25mm (0-1")	60235710
EDM/2	25-50mm (1"-2")	60235720

OUTSIDE MICROMETERS

- Metal construction
- Supplied in a protective case



Description	Graduation	Range	Bishops Code
Metric	0.01mm	0-25mm	60235010
Metric	0.01mm	25-50mm	60235020
Metric	0.01mm	50-75mm	60235030
Metric	0.01mm	75-100mm	60235040
Imperial	0.001"	0"-1"	60235110
Imperial	0.001"	1"-2"	60235120
Imperial	0.001"	2"-3"	60235130
Imperial	0.001"	3"-4"	60235140

6 PIECE MICROMETER SETS

- Metal construction
- Supplied in a wooden case



Description	Graduation	Range	Bishops Code
Metric	0.01mm	0-150mm	60235090
Imperial	0.001"	0"-6"	60235190

EXTERNAL MICROMETERS

- Metric measurements
- Hardened and ground measuring faces
- Thimble and sleeve have a satin chrome finish



Item Code	Accuracy	Size	Bishops Code
EM/01/0-25	0.004mm	0-25mm	60235510
EM/01/25-50	0.004mm	25-50mm	60235520
EM/01/50-75	0.005mm	50-75mm	60235530
EM/01/75-100	0.005mm	75-100mm	60235540

OUTSIDE MICROMETER WITH INTERCHANGEABLE ANVILS

- Metal construction
- Supplied in a wooden case



Range	Bishops Code
0-150mm	60235420
150-300mm	60235430
400-500mm	60235450
500-600mm	60235460



MEASURING TOOL SETS & GAUGES

6 PIECE ENGINEER'S TOOL SET

- Useful for the apprentice and professional engineer
- Supplied in a durable wallet

Includes:

- 1 x Inside caliper – 100mm
- 1 x Outside caliper – 100mm
- 1 x Screw cutting gauge
- 1 x Steel rule – 150mm (6")
- 1 x Pocket scriber – 89mm
- 1 x Centre punch – 4mm



Item Code	Bishops Code
ETS/1/ST	60295100

7 PIECE ENGINEER'S TOOL SET

- Useful for the apprentice and professional engineer
- Supplied in a durable wallet

Includes:

- 1 x Engineer's precision square – 100mm
- 1 x Jenny caliper – 150mm
- 1 x Steel rule – 150mm (6")
- 1 x Double ended scriber – 190mm
- 1 x Centre punch – 4mm
- 1 x Adjustable tap & reamer wrench (DIN 1814)
- 1 x Spring divider – 100mm



Item Code	Bishops Code
ETS/2/ST	60295110

DEPTH GAUGE WITH ROUND HEAD PROTRACTOR

- Able to measure both angles and depths
- Stainless steel construction
- Protractor head has permanent etched graduations reading 0–180° in both directions
- Combined metric and imperial ruler can be locked in place with the knurled thumbnut
- 150mm(6") ruler
- Angular tolerance: ±0.5°



Item Code	Bishops Code
PDG/6	60210010

BORE GAUGE

- Manufactured from stainless steel with permanently engraved graduations
- Accurate taper throughout the length of the gauge makes it a convenient tool for measuring diameters of small holes and slots
- Imperial graduations on one side and metric on the other
- Ideal tool for die makers, machinists and on inspection floors



Item Code	Range	Bishops Code
BG/1-15	1–15mm	60210020
BG/1-15IN	1/32"–5/16"	60210030

TWIST DRILL GAUGE

- Stainless steel with a polished finish
- All gauging surfaces are ground
- Used to check angles or twist drills with a 118° point and up to 2" in diameter



Item Code	Bishops Code
TDG/118	60210100

ROUND WIRE GAUGE

- Made from heavy gauge hardened stainless steel
- Can measure steel wire and rolled steel sheeting
- Designed with metric measurements on one side and gauge markings on the other
- Range: 0–36 gauge, 0.19–7.62mm
- Accuracy within 100 microns

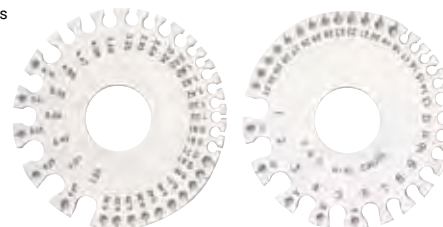

Item Code	Bishops Code
WG/RD/3	60210150

CENTRE GAUGES

- Manufactured from stainless steel
- Used for grinding and setting thread cutting tools
- Ideal for checking the pitch of threads through the permanently deep etched imperial graduations
- These gauges meet the American National or US 60° and the Whitworth or English 55° specifications



Item Code	Description	Bishops Code
CG-55	English Standard - 55° Whitworth	60240100
CG-60	US Standard - 60° American National	60240110

SCREW CUTTING GAUGE

- Stainless steel, hardened and polished
- All gauge surfaces are accurately ground
- Ideal for checking tool angles while cutting threads
- Can measure 55° Whitworth, 60° American, BA, BSF and ACME threads



Item Code	Bishops Code
SCG/4714	60250005

FLEXIGAUGES

- Used for checking clearance of main and connecting rod bearings
- Precision manufactured plastic
- Suitable for automotive, marine and industrial applications
- 310(l) x 30(w) x 30(h)mm
- 10 strips per pack



62052010

Colour	Range	Bishops Code
Green	0.025–0.075mm (0.001"–0.003")	62052010
Red	0.051–0.152mm (0.002"–0.006")	62052020
Blue	0.102–0.229mm (0.004"–0.009")	62052030
Yellow	0.203–0.406mm (0.008"–0.016")	62052040

25 BLADE FEELER GAUGE – METRIC



- Stainless steel blade
- Blade size: 13(w) x 85(l)mm
- Weight: 110g

Includes:

- Sizes: 0.04, 0.05, 0.06, 0.07, 0.08, 0.09, 0.10, 0.15, 0.20, 0.25, 0.30, 0.35, 0.40, 0.45, 0.50, 0.55, 0.60, 0.65, 0.70, 0.75, 0.80, 0.85, 0.90, 0.95 & 1.0mm



Item Code	Bishops Code
77335-25	62020120

FEELER GAUGES – METRIC & IMPERIAL

- Used in engineering and workshops to measure gap widths



62020180

Description	Blade Length	Size Range	Bishops Code
Imperial – 15 Blades	100mm	0.02"–0.025"	62020080
Metric – 25 Blades	200mm	0.05–1.01mm	62020140
Metric – 25 Blades	300mm	0.05–1.01mm	62020160
Imperial & Metric – 32 Blades	75mm	0.038–0.889mm (0.0015"–0.035")	62020180

BENT FEELER GAUGE – IMPERIAL

- Used in engineering and workshops to measure gap widths
- Imperial
- 12 blades
- Blade length: 75mm
- Size range: 0.008"–0.026"



Bishops Code
62020520

THREAD PITCH GAUGES – METRIC & IMPERIAL

- For easy checking of threads on bolts and nuts



Description	Description	Bishops Code
Imperial	31 Blade	60250110
Metric	24 Blade	60250120

GET MORE AT BISHOPS



LATHES

Page 332

STEEL BODY SCRIBERS



- Suitable for machinists, engravers, mechanics and craftsmen
- Designed for scribing and marking into metal, glass, plastics and ceramics

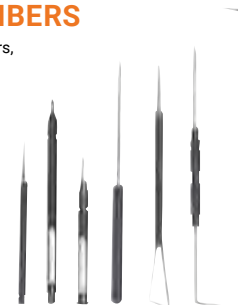

Item Code	Description	Length	Bishops Code
MS/P/3	Scriber With Pocket Clip	89mm	63060070
MS/ST/9	Single Ended – Heavy Duty	175mm	63060080
MS/7	Double Ended (Straight/Bent)	190mm	63060090
MS/H/8	Double Ended (Straight/Bent) – Heavy Duty	230mm	63060100



SQUARES & BEVELS

HAND & CUTTING TOOLS

SQUARE LAYOUT TOOL

- Aluminium alloy
- Laser engraved metric scale
- Ideal for measuring length, height and thickness
- Size: 180mm (7")



Item Code	Bishops Code
W064006	63521113

CARPENTERS/RAFTER SQUARE

- Iron metal construction
- Metric and imperial graduations
- 600mm(24") x 400mm(16")

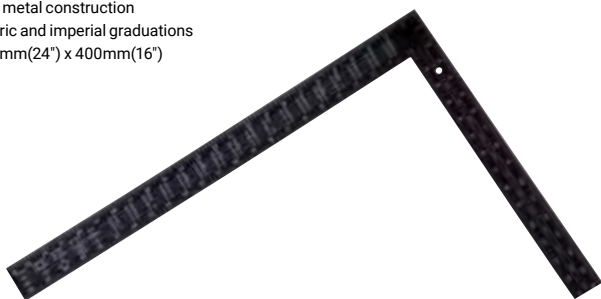

Item Code	Bishops Code
	60030220

TRY SQUARE

- Cast iron base
- Metric and imperial graduations
- Length: 300mm



Item Code	Bishops Code
	60030340

ENGINEER'S PRECISION SQUARES

- Precision steel squares that are second to none
- Useful for jobs where extreme accuracy is required
- Hardened spring steel blades are permanently fixed to the stock by means of tapered self locking rivets ensuring complete rigidity
- Blade and stock are precisely ground to ensure straightness and parallelism
- Working edges of the blades are lapped enhancing accuracy
- Groove on the inner corner of the stock aids in the clearance of burr or dirt



Item Code	Inside Length	Outside Length	Bishops Code
SS/A/4	100mm	75mm	60215030
SS/A/6	150mm	100mm	60215040
SS/A/8	200mm	125mm	60215060

CARPENTERS COMBINATION SQUARE

- Horizontal plumb line
- Two-way layout design
- Metal combined elbow allows measuring of different angles
- Metric graduations
- Length: 300mm



Item Code	Bishops Code
	60030120

COMBINATION SQUARE

- Stainless steel blade rule
- Features square, depth gauge, altimeter, scribe and level
- Size: 300mm (12")



Item Code	Bishops Code
W064002	63521096

SLIDING T-BEVEL

- High impact plastic handle with stainless steel blade
- Cylinder level vial
- Size: 200mm (8")



Item Code	Bishops Code
W064004	63521110

ADJUSTABLE BEVEL

- Suitable for marking dovetails and other unusual angles
- Features an offset slot in the blade to allow a line to be drawn without interference from stock
- Comes with a polished wooden handle, thick brass fittings and a forged steel wingnut
- 250mm



Item Code	Bishops Code
AB/10	60030390

CIRCULAR SAW BLADES

- For handheld circular saws



Item Code	Diameter	Bore	Cut Width	Teeth	Bishops Code
GENERAL PURPOSE FOR WOOD					
2608644561	160mm	25.4mm	2.5mm	40	49450030
2608644562	160mm	25.4mm	2.5mm	60	*2608644562
2608644585	184mm	20mm	2.5mm	20	*2608644585
2608644564	184mm	20mm	2.5mm	40	49450045
2608644565	184mm	20mm	2.5mm	60	*2608644565
2608644567	210mm	25mm	2.5mm	40	*2608644567
2608644572	235mm	25mm	2.5mm	40	49450224
GENERAL PURPOSE FOR WOOD & ALUMINIUM					
2608644570	216mm	30mm	2.5mm	48	*2608644570
2608644576	254mm	30mm	2.5mm	60	*2608644576
2608644578	254mm	30mm	2.5mm	100	*2608644578
2608644582	305mm	30mm	2.8mm	100	49450258
MULTI-MATERIAL					
2608644598	184mm	20mm	2mm	60	*2608644598
2608644603	254mm	30mm	2.7mm	80	*2608644603
2608644605	254mm	30mm	2.7mm	120	*2608644605
2608644607	305mm	30mm	2.7mm	100	49450262

* - SPECIAL ORDER: PLEASE QUOTE ITEM CODE UPON ORDERING THIS PRODUCT

CIRCULAR SAW BLADE SETS

- For handheld circular saws
- Suitable for cutting soft wood and hardwood
- Blade diameter: 184mm
- Bore: 20mm
- Cut width: 2.5mm



Item Code	Description	Teeth
2608644583	2 Piece Saw Blade Set	20/40
2608644584	3 Piece Saw Blade Set	16/24/40

SPECIAL ORDER: PLEASE QUOTE ITEM CODE UPON ORDERING THIS PRODUCT

CORDLESS CIRCULAR SAW BLADE SETS

- For handheld circular saws
- Suitable for cutting soft wood and hardwood
- Blade diameter: 184mm
- Bore: 20mm
- Cut width: 1.6mm



Item Code	Description	Teeth
2608644595	2 Piece Saw Blade Set	20/40

SPECIAL ORDER: PLEASE QUOTE ITEM CODE UPON ORDERING THIS PRODUCT

CORDLESS CIRCULAR SAW BLADES

- For cordless handheld and table circular saws
- Suitable for use on soft wood and hardwood



Item Code	Diameter	Bore	Cut Width	Teeth	Bishops Code
FOR HANDHELD SAWS					
2608644596	160mm	20mm	2.5mm	40	*2608644596
2608840002	165mm	20mm	1.6mm	18	*2608840002
2608840003	165mm	20mm	1.6mm	24	*2608840003
2608840004	165mm	20mm	1.6mm	40	*2608840004
2608644590	184mm	20mm	1.6mm	20	*2608644590
2608644591	184mm	20mm	1.6mm	40	*2608644591
2608644593	210mm	25mm	1.8mm	40	49450125
2608644594	235mm	25mm	1.8mm	60	*2608644594
FOR TABLE SAWS					
2608644647	254mm	30mm	2.2mm	40	*2608644647
2608644648	305mm	30mm	2.2mm	60	*2608644648

* - SPECIAL ORDER: PLEASE QUOTE ITEM CODE UPON ORDERING THIS PRODUCT

DIAMOND CUTTING BLADES

- For wet and dry cutting
- Diamond crystals embedded in the blade segments make these ideal for cutting through hard or abrasive materials

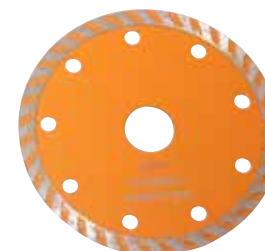

Diameter	Bore	Bishops Code
110mm	20mm	65080110
125mm	22mm	65080130
180mm	22mm	65080150

SEGMENTED DIAMOND BLADES

- For dry cutting
- Diamond crystals embedded in the blade segments make these ideal for cutting through hard or abrasive materials



Diameter	Bore	Bishops Code
110mm	20mm	65080210
125mm	22mm	65080230
175mm	22mm	65080250
230mm	22mm	65080270



DIAMOND, BANDSAW & HACKSAW BLADES

HAND & CUTTING TOOLS

SEGMENTED DIAMOND BLADE

- Suit concrete floor saw
- For wet cutting
- Diamond crystals embedded in the blade segments make these ideal for cutting through hard or abrasive materials
- Diameter: 300mm
- Bore: 25.4mm
- 22 segments, 17mm deep



Diameter	Bore	Bishops Code
300mm	25.4mm	65082300

SEGMENTED DIAMOND BLADE

- For MB14E brick saw
- Cuts normal bricks, tiles and fire bricks
- Diameter: 350mm
- Bore: 25.4mm



Item Code	Bishops Code
14BP	65082345

ASPHALT DIAMOND BLADES

- For premium wet cutting
- Laser welded
- Diamond crystals embedded in the blade segments make these ideal for cutting through asphalt

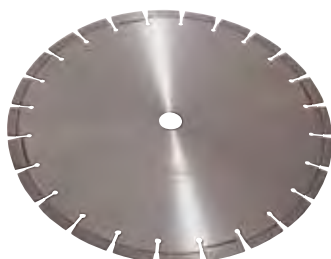

Diameter	Bore	Bishops Code
350mm	25.4mm	65080350
500mm	25.4mm	65080500

FLOOR SAW DIAMOND BLADES

General Purpose:

- For extensive use on materials such as medium aggregate concrete, general masonry products, stock paving bricks, most roofing tiles and hard sandstone

Concrete:

- For use on hard-non abrasive materials such as very hard concrete, class A engineering bricks, 65–100 Newton clay pavers, hard flint aggregate concrete lintels, kerbs, hard paving slabs, hard clay roof tiles and hard slate

Asphalt:

- For use on abrasive material such as asphalt, some asphalt over concrete, lime sandstone, abrasive blocks, green concrete and other highly abrasive applications



Item Code	Description	Size	Bishops Code
18GP	General Purpose	450mm (18")	65082355
16GC	Concrete	400mm (16")	65082350
18AP	Asphalt	450mm (18")	65082358

BANDSAW BLADES

- High speed steel



Dimensions	Thickness	TPI	Bishops Code
1,640(l) x 13(w)mm	0.65mm	14	49445010
2,110(l) x 20(w)mm	0.9mm	10	49445015
2,710(l) x 27(w)mm	0.9mm	4–6	49445050

BI-METAL HACKSAW BLADES

- High speed steel
- Flexible blade
- Suitable for cutting hard materials like mould steel
- Size: 300(l) x 13(w)mm



TPI	Bishops Code
18	49410418
24	49410424
32	49410432

ALL HARD HACKSAW BLADES

- High speed steel
- Suitable for cutting stainless steel and mould steel
- Size: 300(l) x 13(w)mm



TPI	Bishops Code
18	49410518
24	49410524
32	49410532

ALL HARD POWER HACKSAW BLADES

- High speed steel
- Suitable for cutting ordinary material

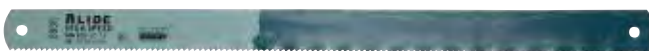

Size	TPI	Bishops Code	Size	TPI	Bishops Code
300 x 25mm	10	49430100	400 x 32mm	10	49430300
300 x 25mm	14	49430110	450 x 32mm	6	49430400
350 x 25mm	14	49430210	450 x 38mm	4	49430450
350 x 32mm	10	49430220	450 x 38mm	6	49430460

EXPERT T-SHANK JIGSAW BLADES – WOOD & METAL



- Bosch Carbide Technology for durability
- Fits T-shank jigsaws



Item Code	Description	Length	TPI	Qty
FAST FOR HARDWOOD				
2608900541	T 144 DHM – Hardwood, WPC Wood Plastic	100mm	3	
CLEAN FOR HARDWOOD				
2608900543	T308 BF – Plastic Coated Board & Multiplex Board	117mm	3	
2608900547	T308 BFP – Plastic Coated Board & Kitchen Countertop	117mm	3	
2608900549	T308 BF & T308 BFP Set – Plastic Coated Board & Kitchen Countertop	117mm	3	
CLEAN FOR WOOD				
2608900550	T308 B – Solid Wood & Plywood	117mm	3	
2608900554	T308 BO – Solid Wood & Plywood	117mm	3	
2608900557	T308 BP – Solid Wood & Plywood	117mm	3	
2608900559	T308 B & T308 BO Set – Solid Wood & Plywood	117mm	3	
FOR STAINLESS STEEL				
2608900561	T118 AHM – Stainless Steel Sheets	83mm	3	

SPECIAL ORDER: PLEASE QUOTE ITEM CODE UPON ORDERING THIS PRODUCT

EXPERT T-SHANK JIGSAW BLADES – SPECIAL APPLICATIONS



- Bosch Carbide Technology for durability
- Fits T-shank jigsaws



Item Code	Description	Length	Pack Qty
CLEAN FOR LAMINATES			
2608900542	T128 BHM – Solid Laminate Vinyl, PVC & High Pressure Laminate	92mm	3
MULTI-MATERIAL			
2608900560	T367 XHM – Steel, Aluminium, Wood With Metal/Nails & Plastics	132mm	3

SPECIAL ORDER: PLEASE QUOTE ITEM CODE UPON ORDERING THIS PRODUCT

EXPERT S-SHANK RECIPROCATING SAW BLADES – WOOD & METAL



- Bosch Carbide Technology for durability
- Fits all S-shank jigsaws



Item Code	Description	Length	TPI	Qty
FOR WOOD				
2608900406	S1242 KHM – Construction Wood & Poly Treated Lumber	300mm	3	1
FOR WOOD & METAL				
2608900384	S715 LHM – Wood With Metal/Nails	190mm	5	1
2608900387	S1122 CHM – Hard Nail Pallets	225mm	8	1
2608900396	S967 XHM – Wood With Metal/Nails, WPC Wood Plastics & Hardwood	150mm	5-7	1
2608900401	S1267 XHM – Wood With Metal/Nails, WPC Wood Plastics & Hardwood	300mm	5-7	1
THIN TOUGH METAL				
2608900359	S522 EHM – Stainless Steel Sheets Up To 4mm	115mm	18	1
2608900360	S922 EHM – Stainless Steel Pipes Up To 4mm	150mm	18	1
THICK TOUGH METAL				
2608900364	S555 CHC – Tough Steel & Cast Iron Up To 12mm	100mm	8	1
2608900365	S955 CHC – Tough Steel & Cast Iron Up To 12mm	150mm	8	1
2608900371	S1255 CHC – Tough Steel & Cast Iron Up To 12mm	300mm	8	1
MEDIUM-THICK TOUGH METAL				
2608900373	S955 HHM – Tough Steel & Stainless Steel Pipes Up To 8mm	150mm	10	1
2608900377	S1255 HHM – Tough Steel & Stainless Steel Pipes Up To 8mm	300mm	10	1

SPECIAL ORDER: PLEASE QUOTE ITEM CODE UPON ORDERING THIS PRODUCT

EXPERT S-SHANK RECIPROCATING SAW BLADES – SPECIAL APPLICATIONS



- Bosch Carbide Technology for durability
- Fits all S-shank jigsaws



Item Code	Description	Length	TPI	Qty
FOR VEHICLE RESCUE				
2608900378	S957 CHM – Tough Steel & Glass Up To 12mm	150mm	8	1
2608900380	S1157 CHM – Tough Steel & Glass Up To 12mm	225mm	8	1
FOR CEMENT CAST IRON				
2608900383	S1750 RD – Cast Iron & Fibre Plastics GFK, CFK Up To 6mm	250mm	50 Grit	1
MULTI-MATERIAL				
2608900389	S956 XHM – Cast Iron, Wood With Metal/Nails, Plastics & Fibre Plastics GFK, CFK	150mm	6-8	1
2608900394	S1256 XHM – Cast Iron, Wood With Metal/Nails, Plastics & Fibre Plastics GFK, CFK	300mm	6-8	1
2608900407	S641 HM – Fibre Cement Board, Drywall Board & Aerated Concrete	150mm	6	1
FOR CONCRETE				
2608900410	S1241 HM – Aerated Concrete	300mm	3	1

SPECIAL ORDER: PLEASE QUOTE ITEM CODE UPON ORDERING THIS PRODUCT

GET MORE AT BISHOPS ▶

ELECTRIC JIGSAW

Page 143



POWER SAW BLADE ATTACHMENTS & CARBIDE BURRS

HAND & CUTTING TOOLS

EXPERT ACZ 105 ET SEGMENT SAW BLADES

- Cuts through grout and mortar as well as solid surface counter tops, abrasive laminates and composites
- Wide body and large curve of sharp carbide teeth
- Precision, stability, and extreme durability with Bosch Carbide Technology
- Starlock mount for optimum power transfer and convenient blade change
- Diameter: 105mm



Item Code	Pack Qty
2608664207	5
2608664208	1

SPECIAL ORDER: PLEASE QUOTE ITEM CODE UPON ORDERING THIS PRODUCT

EXPERT ACZ 85 RD4 GROUT SEGMENT BLADE

- Bosch Diamond Technology for durable cutting edge and long life
- Pointed segment blade is ideal for precision work into corners
- Starlock mount for optimum power transfer and convenient blade change



Item Code	Diameter	Cutting Width	Pack Qty
2608900034	85mm	2mm	1

SPECIAL ORDER: PLEASE QUOTE ITEM CODE UPON ORDERING THIS PRODUCT

EXPERT PLUNGE SAW BLADES

- Bosch Carbide Technology for durability and longevity
- Flat edge is less prone to skidding
- Starlock mount for optimum power transfer and convenient blade change



Item Code	Description	Width	Immersion Depth	Qty
FOR METAL				
2608900014	MetalMax AIZ 32 AIT – Steel & Stainless Steel	32mm	40mm	1
2608900015	MetalMax AIZ 32 AIT – Steel & Stainless Steel	32mm	40mm	5
2608900018	MetalMax AIZ 45 AIT – Steel & Stainless Steel	45mm	40mm	1

Item Code	Description	Width	Immersion Depth	Qty
MULTI-MATERIAL				
2608900024	Multimax AIZ 32 APIT – Stainless Steel, Brick, Fibre Plastic & Fibre Cement	32mm	40mm	1

SPECIAL ORDER: PLEASE QUOTE ITEM CODE UPON ORDERING THIS PRODUCT

CARBIDE BURRS – ALUMNA CUT

- Designed for use on aluminium, brass, copper and soft steel
- Can also be used on non-ferrous materials such as hard plastic, rubber and wood
- Provides easy chip flow and faster stock removal with little or no clogging
- 1/4" shank



Item Code	Description	Head Dia. x Length	Overall Length	Max. Speed	Bishops Code
CYLINDRICAL					
32.95111	Radius End	3/8" x 3/4"	2 1/2"	18,000rpm	49290220
32.95117	Radius End	1/2" x 1"	2 3/4"	16,000rpm	49290240
OVAL					
32.95417	Oval	1/2" x 7/8"	2 5/8"	16,000rpm	49290460

CARBIDE BURRS

- Double cut
- Provides greater tool control
- Design and cut results in rapid stock removal in harder materials
- Produces a finer finish and less chipping
- Engineered for heavy duty applications
- More durable due to the depth of the teeth
- Profile of the teeth are less prone to filling up with chips
- 1/4" shank



Item Code	Description	Head Dia. x Length	Overall Length	Max. Speed	Bishops Code
CYLINDRICAL					
32.547	Plain End	1/4" x 5/8"	2"	33,000rpm	49210090
32.553	Plain End	3/8" x 3/4"	2 1/2"	27,000rpm	49210100
32.556	Plain End	1/2" x 1"	2 3/4"	24,000rpm	49210200
32.613	Radius End	1/4" x 5/8"	2"	33,000rpm	49220090
32.619	Radius End	3/8" x 3/4"	2 1/2"	27,000rpm	49220100
32.622	Radius End	1/2" x 1"	2 3/4"	24,000rpm	49220200
32.589	End Cut	1/2" x 1"	2 3/4"	24,000rpm	49225200
TREE					
32.703	Radius End	1/4" x 5/8"	2"	33,000rpm	49230080
32.706	Radius End	3/8" x 3/4"	2 1/2"	27,000rpm	49230100
32.709	Radius End	1/2" x 1"	2 3/4"	24,000rpm	49230200
32.688	Pointed End	3/8" x 3/4"	2 1/2"	18,000rpm	49240180
32.694	Pointed End	1/2" x 1"	2 3/4"	16,000rpm	49240200
BALL					
32.640	Ball	1/4" x 7/32"	2"	33,000rpm	49250060
32.646	Ball	3/8" x 5/16"	2 1/16"	27,000rpm	49250100
32.649	Ball	1/2" x 7/16"	2 3/16"	24,000rpm	49250200
FLAME					
32.676	Flame	5/16" x 3/8"	2 1/2"	30,000rpm	49260100
32.679	Flame	3/8" x 1 1/16"	2 13/16"	30,000rpm	49260500
32.679	Flame	1/2" x 1 1/4"	3"	24,000rpm	49260300
32.67903	Flame	3/8" x 1 1/16"	3 3/16"	23,000rpm	49260400
32.67911	Flame	3/4" x 1 5/8"	3 3/8"	21,000rpm	49260450
OVAL					
32.664	Oval	3/8" x 1 1/32"	2 1 1/2"	27,000rpm	49270100
32.667	Oval	1/2" x 3/8"	2 5/8"	24,000rpm	49270200
32.670	Oval	5/8" x 1"	2 3/4"	23,000rpm	49270300
INVERTED CONE					
37.035	Plain End	3/8" x 3/8"	2 1/2"	18,000rpm	49280100
TAPER					
32.724	Radius End	5/16" x 7/8"	2 5/8"	30,000rpm	49285200
32.727	Radius End	3/8" x 1 1/16"	2 13/16"	27,000rpm	49285300
32.730	Radius End	1/2" x 1 3/8"	2 7/8"	24,000rpm	49285400
32.733	Radius End	3/8" x 1 1/16"	3 1/16"	23,000rpm	49285600
32.73303	Radius End	3/4" x 1 1/2"	3 1/4"	21,000rpm	49285602

8 PIECE CARBIDE BURR SET

- Double cut 1/4" shank
- Provides greater tool control and produces a finer finish
- Designed for rapid stock removal
- Suitable for heavy duty applications
- Reduces the size and amount of chipping
- Case dimensions: 3 3/16" x 3 3/16" x 3 3/8"

- Includes burrs:**
- 1 x 1/2" Cylindrical plain end
 - 1 x 1/4" Cylindrical radius end
 - 1 x 3/8" Cylindrical radius end
 - 1 x 3/8" Ball
 - 1 x 1/2" Oval
 - 1 x 1/4" Tree pointed end
 - 1 x 1/2" Tree radius end
 - 1 x 1/2" Deburring 90°



Item Code	Bishops Code
32.95417	49295060

WHAT ARE CARBIDE BURRS?

Carbide burrs are a versatile grinding tool that effectively let you replace hand files all together. Many different types exist, and all with their own special purpose. We have listed some options below.

Ball

A ball head is used for cutting concave shapes into the material or to hollow out a larger area. Different sizes allow for sharper detail in carving projects.



Tree

Tree heads are mostly used for rounding off edges to make them smoother or to make concave cuts. The extended tip allows you to reach some of the more difficult areas.



Cone

Cone heads come in two forms; pointed head or round nose. Both of these are designed for surface finishing, particularly in difficult to reach areas.



Cylinder – Plain End

Plain end cylinder heads feature a flat, cut-off end and are mostly designed for finishing. Due to the flat end, they are also suitable for right angled corners.

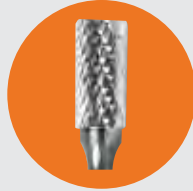

Cylinder – End Cut

End cut cylinders are similar to the plain end style except the end piece features a flat cutting edge. The cut head allows for contour finishing at squared angles.

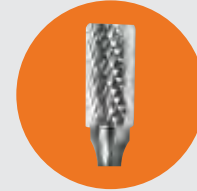

Cylinder – Rounded End

The rounded end cylinder features a dome head which allows for finishing at a range of different angles.



Oval

Oval burrs operate much in the same way as the ball head and is ideal for concave cutting and finishing. The extended head allows it reach some difficult areas that the ball head can't.



Flame

Flame heads allow for open concave cutting and finishing. They operate in a very similar way to oval burrs but with a longer and smoother head.



Single Cut burrs are cut with single right handed flutes called up cuts. These are best suited for heavy stock removal on harder materials.

Alumna Cut burrs are cut with single right handed flutes with wide spacing between each edge. These are used for soft materials with high stock removal and easy chip flow.

Double Cut burrs are cut in a cross formation giving the head more cutting edges. This allows for much quicker stock removal with a smoother finish. This style is best suited for softer materials.

TIP: Do not use your burrs in an electric drill. Instead, use them in a die grinder which will spin the burr at the optimal speed. Spin them too slow and you will chip the teeth.

5 PIECE CARBIDE BURR SET

- Express cut, also known as double cut burrs
- Bright finish tungsten carbide
- General purpose burrs, ideal for rapid stock removal in ferrous metals
- 1/4" shank

Includes:

- 1 x 3/8" Cylindrical end cut burr
- 1 x 3/8" Cylindrical radius burr
- 1 x 1/2" Cylindrical radius burr
- 1 x 3/8" Tree radius burr
- 1 x 1/2" Tree radius burr



Item Code	Bishops Code
6400-S5	49295050

5 PIECE CARBIDE BURR SETS

- Bright finish
- Includes:**
- 1 x Cylindrical square burr
- 1 x Cylindrical radius burr
- 1 x Ball burr
- 1 x Tree radius burr
- 1 x Cylindrical radius Al-cut burr



49295200

Item Code	Diameter	Bishops Code
B900SCB100	1/4"	49295090
B900SCB300	3/8"	49295100
B900SCB500	1/2"	49295200



SELECTING DRILL BITS

Type Material Coating



Selecting the correct drill bit made from the right material will help achieve a great surface finish, hole tolerance, long tool life and overall performance.

Selecting the wrong drill bit can lead to short tool life, structural flaws, poor surface finish and prematurely worn or broken drill bits.

BITS BY TYPE

Wood Drill Bits

Identified by the pointed tips with spurs on either side. These spurs grab the wood and carve it away.

Masonry Drill Bits

These bits feature a carbide insert at the tip which allows it to drill into hard materials such as stone and cinder.

Jobber Drill Bits

These bits are made for general purpose applications. The most common type of drill used in industry, available in many materials and coatings.

Step Drill Bits

These bits gradually increase in diameter. Accompanied by either straight transitions, forming a counterbore, or angled transitions, forming a countersink. These are best suited for soft or thin materials.

Hole Saws

Hole saws are shaped like an open ended cylinder with saw teeth on the end. These are best suited for cutting large holes in a range of materials.

Annular Cutters

Annular cutters leave a solid core at the hole centre. Suitable for drilling large diameters and depths. Commonly used with portable magnetic based drilling machines.

Countersink Drill Bits

These specialised drill bits are designed to cut countersink holes in place for countersunk bolts or screws. Countersink drill bits are suitable for a wide range of materials.

BITS BY MATERIAL & COATING

High Speed Steel (HSS)

HSS is a hard and heat resistant material. It is the most commonly used material, suited for general purpose applications.

Cobalt

These high performance drills are suitable for harder steels and stainless steel. Cobalt is a much harder material and can dissipate heat better at high temperatures. Widely considered an upgrade from HSS.

Carbide

Carbide, commonly used on masonry drill bit inserts, stays sharp for much longer than other materials. It is suitable for use on abrasive materials such as cast iron, non-ferrous metal and fibreglass.

Black Oxide (Surface Treatment)

Helps reduce friction and retain coolant, cutting compound or fluid. Best choice for steels, and not recommended for non-ferrous materials.

Bright Finish

Bright finish refers to uncoated materials. Polished for increased chip flow. These are suited for most general purpose applications.

Titanium Nitride (TiN) Coating

TiN coating provides reduced friction on surfaces, allowing for much higher drilling speeds. It is also very tough for a long tool life. TiN is best suited for metal, wood, PVC and fibreglass.

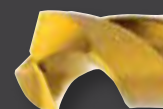
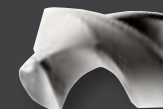
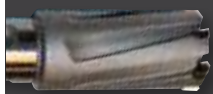
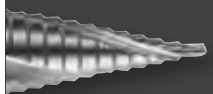
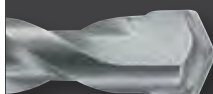

SELECTING DRILL BITS

Shank Size Anatomy



BITS BY SHANK

Hex Shank

A common type of shank due to high torque capabilities. The 6 sides keep it stable when held by a 3 jaw or hex chuck.

Straight Shank

The most common shank form due to high centering accuracy with no wobble. The whole of the drill bit, shaft and shank is usually of the same diameter.

SDS Shank

SDS shanks are made to be quick loading with the help of specialty chucks. They are developed to suit hammering power tools, such as a rotary hammer, the shank moves up and down slightly within the chuck, acting like a piston when hammered. Not all drills support SDS shanks, so be sure to check compatibility first.

Tapered Shank

Tapered shanks are most commonly used within metalworking applications. They fit directly into the drill and lock themselves in place for high centering accuracy. Also referred to as Morse Taper or MTS drills.

Reduced Shank

Reduced shanks are often 1/4", 3/8" or 1/2" and are designed to allow larger diameter drills to be used with a chuck capable of only holding smaller diameter drills.

Can't find the shank you're looking for? Contact Bishops.

BITS BY SIZE

Metric/Imperial Conversion Chart

Metric (mm)	Imperial	Metric (mm)	Imperial	Metric (mm)	Imperial
0.1	-	7	-	16.272	5/16"
0.2	-	7.144	9/32"	16.669	7/32"
0.3	-	7.541	19/64"	17	-
0.397	1/64"	7.938	5/16"	17.066	43/64"
0.4	-	8	-	17.462	11/16"
0.5	-	8.334	7/64"	17.859	45/64"
0.6	-	8.731	11/32"	18	-
0.7	-	9	-	18.256	23/32"
0.794	1/32"	9.128	23/64"	18.653	47/64"
0.8	-	9.525	3/8"	19	-
0.9	-	9.922	25/64"	19.05	3/4"
1	-	10	-	19.447	49/64"
1.191	3/64"	10.319	13/32"	19.844	25/32"
1.588	1/16"	10.716	21/64"	20	-
1.9	-	11	-	20.241	51/64"
1.984	5/64"	11.112	7/16"	20.638	13/16"
2	-	11.509	29/64"	21	-
2.381	3/32"	11.906	15/32"	21.034	53/64"
2.778	7/64"	12	-	21.431	27/32"
3	-	12.303	31/64"	21.828	55/64"
3.175	1/8"	12.7	1/2"	22	-
3.572	9/64"	13	-	22.225	7/8"
3.969	5/32"	13.097	33/64"	22.622	57/64"
4	-	13.494	17/32"	23	-
4.366	11/64"	13.891	35/64"	23.019	29/32"
4.762	3/16"	14	-	23.416	59/64"
5	-	14.288	9/16"	23.812	15/16"
5.159	13/64"	14.684	37/64"	24	-
5.556	7/32"	15	-	24.209	61/64"
5.953	15/64"	15.081	19/32"	24.606	31/32"
6	-	15.478	39/64"	25	-
6.35	1/4"	15.875	5/8"	25.003	63/64"
6.747	11/64"	16	-	25.4	1"

DRILL BIT ANATOMY

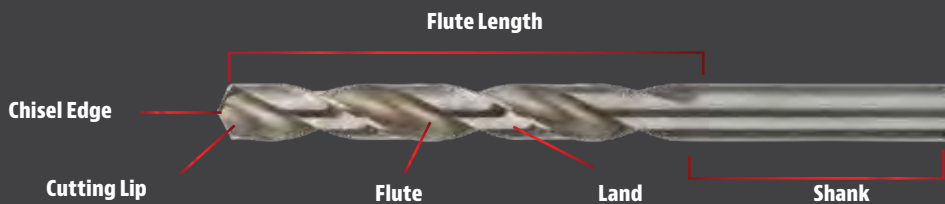



JOBBER DRILLS

JOBBER DRILLS

- Blue ferrous
- High speed steel



HAND & CUTTING TOOLS

Item Code	Size	Bishops Code	Item Code	Size	Bishops Code	Item Code	Size	Bishops Code	Item Code	Size	Bishops Code	Item Code	Size	Bishops Code
D1020100	1mm	46020005	D1020397	5/32"	46010035	D1020676	17/64"	46010070	D1020953	3/8"	46010105	D1021250	12.5mm	46020170
D1020119	3/64"	46010009	D1020400	4mm	46020060	D1020700	7mm	46020110	D1020992	25/64"	46010110	D1021269	1/2"	46010145
D1020150	1.5mm	46020015	D1020437	11/64"	46010040	D1020714	9/32"	46010075	D1021000	10mm	46020140	D1021300	13mm	46020175
D1020159	1/16"	46010010	D1020450	4.5mm	46020075	D1020750	7.5mm	46020115	D1021032	13/32"	46010115	D1021350	13.5mm	46020180
D1020198	5/64"	46010012	D1020476	3/16"	46010045	D1020754	19/64"	46010080	D1021050	10.5mm	46020145	D1021400	14mm	46020185
D1020200	2mm	46020025	D1020500	5mm	46020080	D1020794	5/16"	46010085	D1021072	21/64"	46010120	D1021429	9/16"	46010155
D1020238	3/32"	46010015	D1020516	13/64"	46010050	D1020800	8mm	46020120	D1021100	11mm	46020150	D1021450	14.5mm	46020190
D1020250	2.5mm	46020035	D1020550	5.5mm	46020090	D1020833	21/64"	46010090	D1021111	7/16"	46010125	D1021500	15mm	46020195
D1020278	7/64"	46010020	D1020556	7/32"	46010055	D1020850	8.5mm	46020125	D1021150	11.5mm	46020160	D1021588	5/8"	46010160
D1020300	3mm	46020050	D1020595	15/64"	46010060	D1020873	11/32"	46010095	D1021151	23/64"	46010130	D1021600	16mm	46020205
D1020318	1/8"	46010025	D1020600	6mm	46020095	D1020900	9mm	46020130	D1021191	15/32"	46010135	D1021746	11/16"	46010162
D1020350	3.5mm	46020055	D1020635	1/4"	46010065	D1020913	23/64"	46010100	D1021200	12mm	46020165	-	-	-
D1020357	3/64"	46010030	D1020650	6.5	46020100	D1020950	9.5mm	46020135	D1021231	31/64"	46010140	-	-	-

COBALT HSS JOBBER DRILLS

- For drilling stainless steel and tough materials



Item Code	Size	Bishops Code	Item Code	Size	Bishops Code
2608588336	2.0mm	46020320	D1080750	7.5mm	46020381
D1080250	2.5mm	46020321	D1080850	8.5mm	46020386
2011-3.00	3.0mm	46020330	2608588350	9.0mm	46020390
2608588339	3.5mm	46020335	D1080950	9.5mm	46020393
2608588340	4.0mm	46020360	2608588352	10.0mm	46020400
2608588341	4.5mm	46020363	D1081050	10.5mm	46020402
2608588342	5.0mm	46020365	2608588354	11.0mm	46020405
2608596585	5.5mm	46020367	D1081150	11.5mm	46020406
2608588344	6.0mm	46020370	2608588356	12.0mm	46020420
2608588345	6.5mm	46020375	D1081250	12.5mm	46020421
2608588346	7.0mm	46020377	2608588358	13.0mm	46020425
2608588348	8.0mm	46020380	-	-	-

GET MORE AT BISHOPS



PNEUMATIC DRILLS

Page 147

DO YOU KNOW THE DRILL?

Did you know that ancient drilling techniques consisted of using a long copper tube attached to a wooden dowel. They would then use a bow with the string wrapped around the dowel to cut through stone.

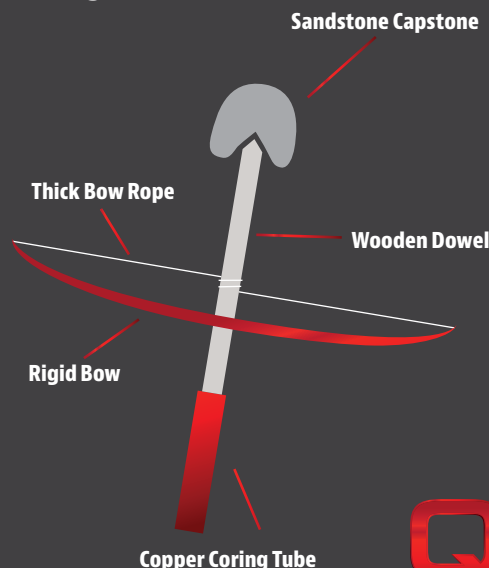

13 PIECE JOBBER DRILL SET – METRIC

- Economy
 - Bright
 - Plastic case
 - Metric
- Includes:**
- Sizes: 1.5–6.5 x 0.5mm



Bishops Code
46440010

13 PIECE JOBBER DRILL SET – IMPERIAL

- Metal case
 - Imperial
- Includes:**
- Sizes: 1/16"–1/4" x 1/64"



Bishops Code
46420010

25 PIECE JOBBER DRILL SET – METRIC

- Economy
 - Bright
 - Plastic case
 - Metric
- Includes:**
- Sizes: 1–13 x 0.5mm



Bishops Code
46440100

29 PIECE JOBBER DRILL SET – IMPERIAL

- Economy
 - Bright
 - Plastic case
 - Imperial
- Includes:**
- Sizes: 1/16"–1/2" x 1/64"



Bishops Code
46420100

JOBBER DRILL SETS – METRIC

- High speed steel
- Cobalt drills come with bronze finish (Gold oxide) for identification purposes. Suitable for stainless and high tensile steels
- Supplied in an ABS case



46445009



46445010

Item Code	Range	No. Drill	Bishops Code
BRIGHT			
2007-M2	1–10 x 0.5mm	19	46430020
2007-M3	1–13 x 0.5mm	25	46430030
COBALT			
2011-M5	1–6.5mm x 0.5 mm, 7–13mm (1mm Increments)	19	46445010
2011-M3	1–13mm x 0.5mm	25	46445009

JOBBER DRILL SETS – METRIC

- High speed steel
- Drill sets also available with Blue finish which is first choice when drilling ferrous materials



46430031



46430035

Item Code	Set No.	Range	No. Drill	Case	Bishops Code
BRIGHT					
D101SM1	SM1	1–6.5 x 0.5mm	12	ABS	46410009
D105V3M	V3M	1–13 x 0.5mm (10.5–13 x 10mm Shank)	25	ABS	46430031
COBALT					
D109SM3	SM3	1–13 x 0.5mm	25	ABS	46430035

JOBBER DRILL SETS – IMPERIAL

- High speed steel
- Cobalt drills come with bronze finish (Gold oxide) for identification purposes. Suitable for stainless and high tensile steels
- Supplied in an ABS case



46410020



46420108



46445020

Item Code	Range	No. Drill	Bishops Code
BRIGHT			
2006-F1	1/16"–1/4" x 1/64"	13	46410010
2006-F2	1/16"–3/8" x 1/64"	21	46410020
2006-F3	1/16"–1/2" x 1/64"	29	46410030
COBALT			
2010-F5	1/16"–1/2" x 1/64"	21	46445020
2010-F3	1/16"–1/2" x 1/64"	29	46420108



JOBBER DRILL SETS & REDUCED SHANK DRILLS

HAND & CUTTING TOOLS

29 PIECE JOBBER DRILL SET – IMPERIAL

- High speed steel
- Bright finish
- Drill sets also available with Blue finish which is first choice when drilling ferrous materials



Item Code	Set No.	Range	No. Drill	Case	Bishops Code
D105V3	V3	1/16"–1/2" X 1/64" (25/64"–1/2" X 3/64" Shanks)	29	ABS	46420104

111 PIECE BRIGHT FINISH DRILL SET – METRIC

- Bright finish high speed steel
- The drills have no surface treatment and come in the as-ground condition
- General purpose drills, particularly suited to non-ferrous applications

Includes:

- Jobber drills – 1, 1.5, 2, 2.5, 3, 3.5 & 4mm (10 of each)
- Jobber drills – 4.5, 5, 5.5, 6, 6.5, 8 & 10mm (5 of each)
- 5 x #30 Double ended panel drills
- 1 x 60ml Cutting fluid



Item Code	Bishops Code
2007-MA1	46445005

BLUE FLUTE REDUCED SHANK DRILLS

- High speed steel
- Individually packed



Item Code	Size	Bishops Code	Item Code	Size	Bishops Code
3/8" SHANK					
2646-1/2	1/2"	46210010	–	–	–
1/2" SHANK					
D1881588	5/8"	46210060	D1882223	7/8"	46210130
D1881746	1 1/16"	46210080	D1882540	1"	46210150
D1881905	3/4"	46210100	D1882699	1 1/16"	46210160
D1882064	13/16"	46210110	D1883016	1 3/16"	46210180
D1882143	27/32"	46210120	D1883175	1 1/4"	46210190
12.5MM SHANK					
D1881350	13.5mm	46220006	D1881900	19mm	46220090
D1881450	14.5mm	46220020	D1882000	20mm	46220100
D1881500	15mm	46220030	D1882100	21mm	46220105
D1881550	15.5mm	46220031	D1882200	22mm	46220110
D1881600	16mm	46220040	D1882300	23mm	46220115
D1881650	16.5mm	46220050	D1882400	24mm	46220120
D1881700	17mm	46220060	D1882500	25mm	46220125
D1881750	17.5mm	46220070	D1882600	26mm	46220126
D1881800	18mm	46220080	D1882800	28mm	46220127
D1881850	18.5mm	46220085	D1883000	30mm	46220128

REDUCED SHANK DRILL SETS



46410064

Item Code	Set No.	Range	No. Drills	Case	Bishops Code
D188SM8R	SM8R	14.0, 15.0, 16.0, 16.5, 18.0, 20.0, 22.0, 25.0 With 12.5mm Shanks	8	Plastic	46410062
D188RS16	RS16	17/32", 9/16", 19/32", 5/8", 21/32", 11/16", 23/32", 3/4", 25/32", 13/16", 27/32", 7/8", 29/32", 15/16", 31/32", 1" With 1/2" Shanks	16	Plastic	46410064

DO YOU KNOW THE DRILL?

Did you know that the length of the flute is generally between 9 and 14 times the diameter of the drill bit, depending on the drill bit size?

Eg. A 1/2" (12.7mm) diameter drill will be able to drill a hole 4 1/2" (114.3mm) deep, since it is 9 times the diameter in length.

A 3/8" (9.5mm) diameter drill can drill a hole 1 1/4" (31.8mm) deep, since it is 13 times the diameter in flute length.

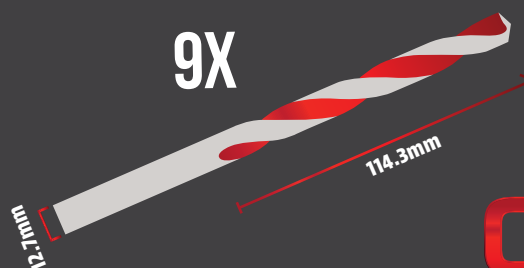

TAPER SHANK DRILLS

- Blue ferrous
- High speed steel



Item Code	Size	Bishops Code	Item Code	Size	Bishops Code	Item Code	Size	Bishops Code	Item Code	Size	Bishops Code
NO. 1 MORSE											
D1151200	12mm	46620004	D1151269	½"	46610010	D1151350	13.5mm	46620015	-	-	-
D1151250	12.5mm	46620005	D1151300	13mm	46620010	D1151400	14mm	46620020	-	-	-
NO. 2 MORSE											
D1151500	15mm	46620023	D1151700	17mm	46620028	D1151905	¾"	46610090	D1152100	21mm	46620050
D1151588	⅝"	46610050	D1151746	1⅜"	46610070	D1151950	19.5mm	46620043	D1152200	22mm	46620055
D1151600	16mm	46620025	D1151750	17.5mm	46620029	D1152000	20mm	46620045	D1152223	⅞"	46610130
D1151650	16.5mm	46620026	D1151800	18mm	46620030	D1152050	20.5mm	46620047	D1152300	23mm	46620062
D1151667	2⅛"	46610060	D1151900	19mm	46620040	D1152064	1⅝"	46610110	-	-	-
NO. 3 MORSE											
D1152350	23.5mm	46620065	D1152540	1"	46610170	D1152858	1⅞"	46610210	D1153016	1⅜"	46610230
D1152381	1⅝"	46610150	D1152600	26mm	46620085	D1152900	29mm	46620098	D1153096	1⅞"	46610240
D1152400	24mm	46620070	D1152700	27mm	46620092	D1152937	1⅞"	46610220	D1153175	1¼"	46610250
D1152500	25mm	46620080	D1152800	28mm	46620095	D1153000	30mm	46620105	-	-	-
NO. 4 MORSE											
D1153334	1⅝"	46610255	D1153600	36mm	46620135	D1154000	40mm	46620141	D1154500	45mm	46620145
D1153493	1⅞"	46610260	D1153800	38mm	46620139	D1154128	1⅞"	46610280	D1154763	1⅞"	46610300
D1153500	35mm	46620132	D1153810	1½"	46610270	D1154445	1¾"	46610290	D1155080	2"	46610310

A GRADE REDUCTION SLEEVES

- Manufactured from case hardened hi-tensile steel (20 MnCr5/SAE8620)
- Fully hardened and are ground on the inside and outside
- Used to adapt smaller morse taper shank tools to larger machine spindles
- The co-centricity and taper angles are precisely controlled which allows perfect locking and concentric movement to the tool held



Item Code	Description	Length	Bishops Code
DSA/2-1	Outside MT2, Inside MT1	92mm	76040135
DSA/3-1	Outside MT3, Inside MT1	99mm	76040130
DSA/3-2	Outside MT3, Inside MT2	112mm	76040230
DSA/4-2	Outside MT4, Inside MT2	124mm	76040240
DSA/4-3	Outside MT4, Inside MT3	140mm	76040340
DSA/5-3	Outside MT5, Inside MT3	156mm	76040350
DSA/5-4	Outside MT5, Inside MT4	218mm	76040450
DSA/6-3	Outside MT6, Inside MT3	218mm	76040360
DSA/6-5	Outside MT6, Inside MT5	218mm	76040560

GET MORE AT BISHOPS



TAPES
From Page 337

TOOL POUCH

Page 162





MASONRY DRILLS

- Single brick
- Ideally suited for use with hammer drills
- Designed for masonry, concrete and brick applications



Diameter	Length	Bishops Code	Diameter	Length	Bishops Code
6mm	150mm	46820030	13mm	150mm	46820090
6.5mm	150mm	46820040	14mm	150mm	46820100
8mm	150mm	46820050	16mm	150mm	46820110
10mm	150mm	46820060	20mm	160mm	46820130
12mm	150mm	46820080	25mm	160mm	46820150

STANDARD FIXING MASONRY DRILLS

- CYL-3 heavy duty drill bit
- Suitable for drilling holes in concrete, masonry, limestone, and natural and artificial stone



Item Code	Shank Diameter	Working Length	Overall Length	Bishops Code
D6000500	5mm	50mm	85mm	46810050
D6000550	5.5mm	45mm	85mm	46810060
D6000600	6mm	60mm	100mm	46810065
D6000650	6.5mm	60mm	100mm	46810070
D6000700	7mm	60mm	100mm	46810080
D6000800	8mm	80mm	120mm	46810090
D6001000	10mm	80mm	120mm	46810110
D6001200	12mm	90mm	100mm	46810130
D6001300	13mm	90mm	120mm	46810140

DOUBLE BRICK MASONRY DRILLS

- Impact and bend resistant hammer drill bits
- Guarantees longer life in concrete
- Unique design with deep U-shaped flute effectively prevents clogging caused by drilling dust, producing a higher drilling rate
- Tungsten carbide plated tip
- Manufactured to ISO 5468
- Suitable for fixing holes and drilling holes in concrete, masonry, limestone, natural and artificial stone
- Silver-grey in colour, sandblasted



Item Code	Shank Diameter	Working Length	Overall Length	Bishops Code
D6021600	16mm	350mm	400mm	46830045
D6022000	20mm	350mm	400mm	46830050

SDS PLUS-5 DRILL BITS

- Suitable for concrete, reinforced concrete, granite and bricks
- For hammer drilling into very hard materials
- Highly Durable Tungsten carbide tip – aggressive, 2 cutter design with diameter optimised brazing to increase the hardness
- Active self-centering tip – for improved accuracy and centering
- Carbide relief grooves help move the dust faster to the flute and prevent clogging
- Four flute turbo design for fast removal of drilling dust
- PGM certified to ensure the bit drills to the exact tolerance and diameter



Item Code	Diameter	Working Length	Overall Length	Bishops Code
165101050	5mm	100mm	160mm	46840014
D6120600	6mm	50mm	110mm	46840030
165102060	6mm	150mm	210mm	46840034
165101060	6mm	100mm	160mm	46840040
D6120650	6.5mm	50mm	110mm	46840050
165101065	6.5mm	100mm	160mm	46840060
165102065	6.5mm	150mm	210mm	46840065
D6120800	8mm	50mm	110mm	46840070
165102080	8mm	150mm	210mm	46840084
2608578197	8mm	100mm	160mm	46840080
165101100	10mm	100mm	160mm	46840090
2608578206	10mm	200mm	260mm	46840102
165101120	12mm	100mm	160mm	46840120
D6141200	12mm	150mm	210mm	46840130
D6151200	12mm	200mm	260mm	46840132
D6131300	13mm	100mm	160mm	46840150
D6141400	14mm	150mm	210mm	46840180
D6151400	14mm	200mm	260mm	46840182
D6141600	16mm	150mm	210mm	46840200
D6151600	16mm	200mm	260mm	46840204
D6152000	20mm	200mm	260mm	46840280

EXPERT SDS PLUS-7X HAMMER DRILL BITS



- Advanced full carbide 4-cutter head design
- Effectively punches through rebar
- Suitable for construction professionals drilling concrete and reinforced concrete regularly
- Fits all SDS plus rotary hammer drills
- 10 per pack



Item Code	Diameter	Working Length	Total Length
2608900158	5mm	100mm	165mm
2608900159	6mm	50mm	115mm
2608900160	6mm	100mm	165mm
2608900163	6.5mm	100mm	165mm
2608900164	6.5mm	150mm	215mm
2608900167	8mm	100mm	165mm
2608900168	8mm	150mm	215mm
2608900169	8mm	200mm	265mm
2608900170	10mm	100mm	165mm
2608900171	10mm	150mm	215mm
2608900172	10mm	200mm	265mm
2608900173	12mm	100mm	165mm
2608900174	12mm	150mm	215mm
2608900175	12mm	200mm	265mm
2608900176	14mm	200mm	265mm
2608900177	16mm	200mm	265mm

SPECIAL ORDER: PLEASE QUOTE ITEM CODE UPON ORDERING THIS PRODUCT

DO YOU KNOW THE DRILL?

Did you know that the world's largest cutting head sits on the front of "Bertha," a 7,000 tonne tunnel drilling machine. The drill bit is an impressive 17.5m (57.5ft) wide!

17.5m

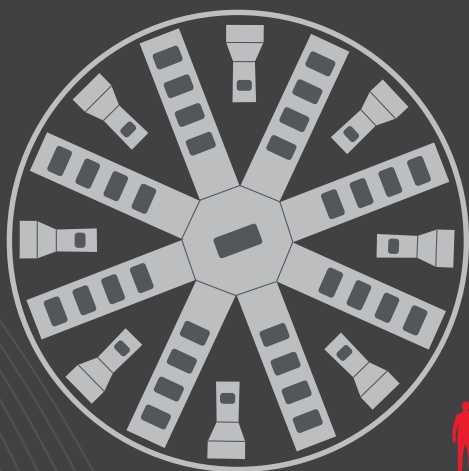

THAT'S ABOUT **3X** TALLER THAN AN AVERAGE ADULT GIRAFFE!



STEP DRILLS

- High speed steel
- Bright finish
- Two flutes
- Step depth: 5mm



Increment	Diameter	Bishops Code
1/32"	1/8"-1/2"	46450320
1/16"	1/4"-3/4"	46450322
1mm	4-12mm	46450324
2mm	4-20mm	46450326
2mm	6-30mm	46450328

STEP DRILLS

- High speed steel
- Spiral or straight flute
- 11 steps



46450327

Item Code	Flute	Increments	Diameter	Bishops Code
107SD0636	Spiral	3mm	6-36mm	46450310
149040250	Straight	2mm	4-25mm	46450327

3 PIECE STEP DRILL SET

- Titanium Nitride (TiN) coated spiral flute step drills
- High performance point provides faster starting and reduces bit wander
- 3 flattened shank prevents slipping in drill chuck
- The TiN coating dissipates heat, reduces friction and cold welding
- Designed with a deburring groove
- Includes diameter sizes: 4-12mm, 4-20mm & 4-30mm



Item Code	Bishops Code
2602-S1	46450500

GET MORE AT BISHOPS ▶



EARPLUGS

Page 25



CENTRE, END & SLOT DRILLS & ADJUSTABLE REAMERS

HAND & CUTTING TOOLS

CENTRE DRILLS

- High speed steel
- Designed for creating a starting hole for a larger bit or for mounting to a lathe centre



Size	Bishops Code	Size	Bishops Code
No. 1	46060010	No. 5	46060050
No. 2	46060020	No. 6	46060060
No. 3	46060030	No. 7	46060070
No. 4	46060040	No. 8	46060080

THREADED SHANK ENDMILLS – METRIC

- High speed steel
- 4 flute
- Short length



Diameter	Bishops Code	Diameter	Bishops Code
3mm	47030003	12mm	47030012
4mm	47030004	14mm	47030014
5mm	47030005	16mm	47030016
6mm	47030006	18mm	47030018
8mm	47030008	20mm	47030020
10mm	47030010	22mm	–

THREADED SHANK ENDMILLS – IMPERIAL

- High speed steel
- Short
- 4 flute



Diameter	Bishops Code	Diameter	Bishops Code
1/8"	47010012	1/2"	47010050
3/16"	47010018	5/8"	47010062
1/4"	47010025	3/4"	47010075
5/16"	47010031	7/8"	47010087
3/8"	47010037	1"	47010100
7/16"	47010043	–	–

PLAIN SHANK ENDMILLS – METRIC

- High speed steel
- 4 flute
- Short length



Diameter	Bishops Code	Diameter	Bishops Code
3mm	47035003	10mm	47035010
4mm	47035004	12mm	47035012
5mm	47035005	14mm	47035014
6mm	47035006	16mm	47035016
7mm	47035007	18mm	47035018
8mm	47035008	20mm	47035020

PLAIN SHANK ENDMILLS – IMPERIAL

- High speed steel
- 4 flute



Diameter	Bishops Code	Diameter	Bishops Code
SHORT			
1/8"	47015012	3/8"	47015037
3/16"	47015018	1/2"	47015050
1/4"	47015025	5/8"	47015062
5/16"	47015031	1"	47015100
LONG			
1/2"	47025050	1"	47020080
3/4"	47025075	–	–

SLOT DRILLS – METRIC

- High speed steel
- 2 flute
- Threaded end
- Short length
- Suitable for soft steel and non-ferrous material



Item Code	Diameter	Bishops Code	Item Code	Diameter	Bishops Code
E1040500	5mm	47070005	E1041200	12mm	47070012
E1040600	6mm	47070006	E1041400	14mm	47070014
E1040800	8mm	47070008	E1041600	16mm	47070016
E1041000	10mm	47070010	E1042000	20mm	47070020

SLOT DRILLS – IMPERIAL

- High speed steel
- 2 flute
- Threaded end
- Suitable for soft steel and non-ferrous material



Item Code	Diameter	Bishops Code	Item Code	Diameter	Bishops Code
SHORT					
E1040794	5/16"	47050031	E1041270	1/2"	47050050
E1040953	3/8"	47050037	E1041588	5/8"	47050062
E1041111	7/16"	47050043	E1041905	3/4"	47050075
LONG					
E1061270	1/2"	47060050	E1062540	1"	47060100
E1061905	3/4"	47060075	–	–	–

ADJUSTABLE REAMER SETS

- Useful precision tools ideal for any engineering or auto-repair shop
- Ideal for use on steel or non-ferrous metals
- Reamer blades are made from High Speed Steel, accurately hardened 60-64 HRC and relief ground
- Each reamer has a chamfer or lead on the front end which helps to make a quick start in reaming operation
- Reamers expand by loosening one adjusting nut and tightening the other

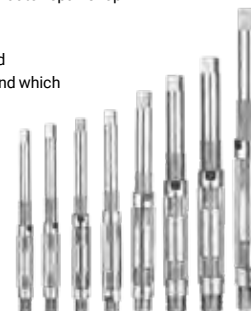

AHR/8/ST

Item Code	Description	Sizes Included	Bishops Code
AHR/8/ST	8 Piece Set	15/32"–1 1/16" (12–27mm)	47096090
AHR/11/ST	11 Piece Set	15/32"–1 1/2" (12–38mm)	47096095



PREMIUM DRILLING & CUTTING TOOLS FOR THE HANDYMAN THROUGH TO THE PROFESSIONAL TRADESPERSON

With years of experience across numerous markets, Qcut represents precision and durability in cutting tools and accessories.

Developed from an engineering perspective – by machinists for machinists, Qcut products are manufactured with leading material and technology in state-of-the-art facilities to ensure lasting quality and precision you'd expect from a leading product.

EXCLUSIVE TO  BISHOPS

ANNULAR CUTTERS

- CNC ground with multi-cut geometry
- Smooth and fast cutting
- Produce burr-free finished holes
- 3/4" universal shank to suit most standard machines
- Available in sizes up to 52mm in diameter, in 25 and 50mm depths of cut
- Pilot pins sold separately



Item Code	Size	Bishops Code	Item Code	Size	Bishops Code
25MM DEPTH OF CUT – SHORT					
7400-12X25	12mm	49480120	7400-22X25	22mm	49480220
7400-13X25	13mm	49480130	7400-23X25	23mm	49480230
7400-14X25	14mm	49480140	7400-24X25	24mm	49480240
7400-15X25	15mm	49480150	7400-25X25	25mm	49480250
7400-16X25	16mm	49480160	7400-26X25	26mm	49480260
7400-17X25	17mm	49480170	7400-27X25	27mm	49480270
7400-18X25	18mm	49480180	7400-28X25	28mm	49480280
7400-19X25	19mm	49480190	7400-30X25	30mm	49480300
7400-20X25	20mm	49480200	7400-32X25	32mm	49480320
7400-21X25	21mm	49480210	7400-50X25	50mm	49480500

Item Code	Size	Bishops Code	Item Code	Size	Bishops Code
50MM DEPTH OF CUT – LONG					
7400-12X50	12mm	49480620	7400-24X50	24mm	49480740
7400-13X50	13mm	49480630	7400-25X50	25mm	49480750
7400-14X50	14mm	49480640	7400-26X50	26mm	49480760
7400-15X50	15mm	49480650	7400-27X50	27mm	49480770
7400-16X50	16mm	49480660	7400-28X50	28mm	49480780
7400-17X50	17mm	49480670	7400-29X50	29mm	49480785
7400-18X50	18mm	49480680	7400-30X50	30mm	49480800
7400-19X50	19mm	49480690	7400-32X50	32mm	49480820
7400-20X50	20mm	49480700	7400-36X50	36mm	49480860
7400-21X50	21mm	49480710	7400-38X50	38mm	49480870
7400-22X50	22mm	49480720	7400-40X50	40mm	49480880
7400-23X50	23mm	49480730	-	-	-

8 PIECE ROTABROACH CUTTER SETS

- High quality M2 High Speed Steel (HSS)
- Suitable for most magnetic drilling machines, multi-fit shank
- Suitable for use in metal plate, construction steel, alloy steel, I-beam steel, steel pipes, cast iron and rail steel
- Size range: 14–26mm
- Secured in sturdy plastic hard case



ASHSSM-SET



Item Code	Description	Bishops Code
ASHSSM-SET	25mm Cut Depth	49480550
ALHSSM-SET	50mm Cut Depth	49480950

ROTABROACH PILOT PINS



SHORT		LONG	
To Suit Cutter Size	Bishops Code	To Suit Cutter Size	Bishops Code
19–52mm	49485200	12mm	49485140
12–13mm	49485310	12–13mm	49485311
14–70mm	49485312	14–70mm	49485313



HOLESAWS & ARBORS

HAND & CUTTING TOOLS

BI-METAL HOLESAWS

- Bi-metal cobalt high speed steel
- Varied pitch teeth
- Cutting depth: 36mm



Item Code	Diameter	Bishops Code	Item Code	Diameter	Bishops Code
H1050160	16mm	49460016	H1050630	64mm	49460064
H1050190	19mm	49460019	H1050700	70mm	49460070
H1050200	20mm	49460020	H1050730	73mm	49460073
H1050220	22mm	49460022	H1050760	76mm	49460076
H1050250	25mm	49460025	H1050790	79mm	49460079
H1050290	29mm	49460029	H1050830	83mm	49460083
H1050320	32mm	49460032	H1050890	89mm	49460089
H1050350	35mm	49460035	H1050920	92mm	49460092
H1050380	38mm	49460038	H1050950	95mm	49460095
H1050400	40mm	49460040	H1051020	102mm	49460102
H1050410	41mm	49460041	H1051050	105mm	49460105
H1050440	44mm	49460044	H1051110	111mm	49460111
H1050480	48mm	49460048	H1051140	114mm	49460114
H1050510	51mm	49460051	H1051210	121mm	49460121
H1050540	54mm	49460054	H1051270	127mm	49460127
H1050570	57mm	49460057	H1051400	140mm	49460140
H1050600	60mm	49460060	H1051520	152mm	49460152

9 PIECE BI-METAL HOLESAW SET

- Premium quality bi-metal high speed steel holesaws
- Suitable for use with steel, aluminium, brass, cast iron, plastic, wood and more

Includes:

- 6 x holesaws – 16, 20, 25, 32, 40 & 50mm
- 1 x Posi-Lock mandrel - 7/16" hex shank
- 1 x hex shank mandrel - 3/8"
- 1 x pilot drill - 1/4" x 3-1/2"



Item Code	Bishops Code
7010-S4	49470501

11 PIECE BI-METAL HOLESAW SET

- Bi-metal cobalt high speed steel
- Cutting depth: 32mm

Includes:

- 11 x Holesaws – 19, 22, 25, 32, 35, 38, 44, 51, 54, 63 & 76mm
- Adaptors – QFX, 3 x QF4
- Pilot drill



Item Code	Bishops Code
H125BM3	49470507

18 PIECE BI-METAL HOLESAW SET

- High speed steel bi-metal holesaws
- Ideal for use with cordless tools
- Anti-friction coating
- RIP GUARD™ tooth design for long tool life and more durable cutting
- Suitable for cutting metal, non-ferrous metal, aluminium, wood, plaster and PVC
- 3.5tpi



49470506



49470525

Item Code	Description	Bishops Code
49224097	18 Piece Electrician's Kit – Includes: 2 x 16mm, 2 x 20mm, 2 x 22mm, 2 x 25mm, 2 x 32mm, 2 x 40mm & 2 x 51mm Holesaws, 2 x Arbors & 2 x Pilot Pins	49470506
49224185	28 Piece General Purpose Kit – Includes: 19, 22, 25, 29, 32, 35, 38, 44, 51, 54, 57, 64, 67, 76, 83, 86, 92, 95, 105, 108, 114 & 121mm Holesaws, 3 x Arbors, 3 x Pilot Pins	49470525

14 PIECE HOLESAW SET

- Economy
- Metric
- Includes:**
- 11 x Holesaws - 19, 22, 25, 29, 35, 38, 44, 51, 57, 64 and 75mm
- 2 x Arbors
- 1 x Adaptor



Item Code	Bishops Code
	49470560

HOLESAW ARBORS



Description	Shank	Bishops Code
Standard Arbor to Suit 14–30mm Holesaws	9.5mm	49470010
Standard Arbor to Suit 32–152mm Holesaws	13mm	49470013
Quick Change Arbor to Suit 32–152mm Holesaws	16mm	49470070

COBALT SQUARE TOOLBITS

- High speed steel
- Cobalt



Size	Bishops Code	Size	Bishops Code
3/16" x 2 1/2"	47210010	3/8" x 4"	47210110
1/4" x 2 1/2"	47210030	3/8" x 6"	47210120
1/4" x 4"	47210050	1/2" x 4"	47210150
5/16" x 2 1/2"	47210070	1/2" x 6"	47210160
5/16" x 4"	47210090	5/8" x 4 1/2"	47210170
3/8" x 3"	47210100	1" x 7"	47210210

ROUND TOOL BITS

- High speed steel
- M2



Size	Bishops Code
3/16" x 4"	47230030
1/4" x 4"	47230060
5/16" x 4"	47230080
3/8" x 4"	47230100
1/2" x 4"	47230120

6 PIECE SCREW EXTRACTOR SET

- Round type
- Includes size #1 to #6



Bishops Code
48690220

SCREW EXTRACTOR SETS

- Carbon steel
- Removes broken studs, bolts, screws and fittings
- Spiral flute for increased grip



Item Code	Description	Bishops Code
9900-SM1	5 Piece Extractor Set – Includes: #1–#5	48690150
9900-SM2	10 Piece Extractor & Drill Set – Includes: #1–#5 Extractors & 5/64"–19/64" Stub Drills	48690180

GROUND THREAD TAP SETS – METRIC FINE

- Carbon steel



Diameter	Pitch	Bishops Code	Diameter	Pitch	Bishops Code
8mm	1.0	48210080	16mm	1.5	48210160
10mm	1.0	48210100	18mm	1.5	48210180
10mm	1.25	48210104	20mm	1.5	48210200
12mm	1.25 Spark Plug	48210120	22mm	1.5	48210220
12mm	1.5	48210124	24mm	2.0	48210240
14mm	1.5	48210144	–	–	–

GROUND THREAD TAPS – METRIC COARSE

- Carbon steel



Diameter	Pitch	Bishops Code	Diameter	Pitch	Bishops Code
3mm	0.5	48010010	12mm	1.75	48010120
4mm	0.7	48010040	14mm	2.0	48010140
5mm	0.8	48010050	16mm	2.0	48010160
6mm	1.0	48010060	18mm	2.5	48010180
7mm	1.0	48010070	20mm	2.5	48010200
8mm	1.25	48010080	22mm	2.5	48010220
10mm	1.5	48010100	24mm	3.0	48010240
11mm	1.5	48010110	–	–	–

GROUND THREAD TAP SETS – UNC

- Carbon steel



Diameter	TPI	Bishops Code	Diameter	TPI	Bishops Code
1/4"	20	47410300	9/16"	12	47410400
5/16"	18	47410320	5/8"	11	47410420
3/8"	16	47410340	3/4"	10	47410460
7/16"	14	47410360	7/8"	9	47410500
1/2"	13	47410380	1"	8	47410540

GROUND THREAD TAP SETS – UNF

- Carbon steel



Diameter	TPI	Bishops Code	Diameter	TPI	Bishops Code
1/4"	28	47610300	9/16"	18	47610400
5/16"	24	47610320	5/8"	18	47610420
3/8"	24	47610340	3/4"	16	47610460
7/16"	20	47610360	7/8"	14	47610500
1/2"	20	47610380	1"	12	47610540



TAPPING DRILL SIZES

All sizes are "suggested sizes" only and may be varied to suit individual requirements



Metric

Metric Coarse (60°)

Tap Size	Pitch	Tapping Drill	Tap Size	Pitch	Tapping Drill
M1.6	0.35mm	1.25mm	M18	2.50mm	15.50mm
M2	0.40mm	1.60mm	M20	2.50mm	17.50mm
M2.5	0.45mm	2.05mm	M22	2.50mm	19.50mm
M3	0.50mm	2.50mm	M24	3.00mm	21.00mm
M3.5	0.60mm	2.90mm	M27	3.00mm	24.00mm
M4	0.70mm	3.30mm	M30	3.50mm	26.50mm
M4.5	0.75mm	3.70mm	M33	3.50mm	29.50mm
M5	0.80mm	4.20mm	M36	4.00mm	32.00mm
M6	1.00mm	5.00mm	M42	4.50mm	37.50mm
M8	1.25mm	6.80mm	M45	4.50mm	40.50mm
M10	1.50mm	8.50mm	M48	5.00mm	43.00mm
M12	1.75mm	10.20mm	M52	5.00mm	47.00mm
M14	2.00mm	12.00mm	M56	5.50mm	50.50mm
M16	2.00mm	14.00mm	-	-	-

The tapping drill sizes indicated are recommended only and should give approximately 75% of thread depth

Metric Fine

ISO Metric Fine (60°)

Tap Size	Pitch	Tapping Drill	Tap Size	Pitch	Tapping Drill
M3	0.35mm	2.65mm	M20*	1.50mm	18.50mm
M4	0.50mm	3.50mm	M22	1.50mm	20.50mm
M5	0.50mm	4.50mm	M24	2.00mm	22.00mm
M6	0.75mm	5.20mm	M25*	1.50mm	23.50mm
M8	1.00mm	7.00mm	M27	2.00mm	25.00mm
M10	1.25mm	8.80mm	M30	2.00mm	28.00mm
M12	1.25mm	10.80mm	M32*	1.50mm	30.50mm
M14	1.50mm	12.50mm	M40*	1.50mm	38.50mm
M16*	1.50mm	14.50mm	M50*	1.50mm	48.50mm

Metric Fine - Spark Plug

M10	1.00mm	9.00mm	M14	1.25mm	12.80mm
M12	1.25mm	10.80mm	M18	1.50mm	16.50mm

* Metric Conduit

8UN (8tpi)

Unified National Form (60°)

Tap Size	TPI	Tapping Drill	Tap Size	TPI	Tapping Drill
1/8"	8	25.50mm	1/8"	8	38.00mm
1/4"	8	28.50mm	1/4"	8	41.50mm
3/8"	8	31.75mm	3/8"	8	44.50mm
1/2"	8	35.00mm	2"	8	47.50mm

UNC

Unified National Coarse (60°)

Tap Size	TPI	Tapping Drill	Tap Size	TPI	Tapping Drill
#1 (0.073)	64	1.55mm	1/2"	13	10.80mm
#2 (0.086)	56	1.85mm	5/16"	12	12.20mm
#3 (0.099)	48	2.10mm	3/8"	11	13.50mm
#4 (0.112)	40	2.25mm	3/4"	10	16.50mm
#5 (0.125)	40	2.60mm	7/8"	9	19.50mm
#6 (0.138)	32	2.75mm	1"	8	22.25mm
#8 (0.164)	32	3.40mm	1 1/8"	7	25.00mm
#10 (0.190)	24	3.80mm	1 1/4"	7	28.00mm
#12 (0.216)	24	4.50mm	1 1/2"	6	30.75mm
1/4"	20	5.10mm	1 3/4"	6	34.00mm
3/8"	18	6.60mm	1 7/8"	5	39.50mm
1/2"	16	8.00mm	2"	4.5	45.00mm
3/4"	14	9.40mm	2 1/4"	4.5	52.00mm

UNF

Unified National Fine (60°)

Tap Size	TPI	Tapping Drill	Tap Size	TPI	Tapping Drill
#2 (0.0860)	64	1.90mm	1/16"	20	9.90mm
#3 (0.099)	56	2.15mm	1/8"	20	11.50mm
#4 (0.112)	48	2.40mm	3/16"	18	12.90mm
#5 (0.125)	44	2.70mm	1/4"	18	14.50mm
#6 (0.138)	40	2.95mm	3/8"	16	17.50mm
#8 (0.164)	36	3.50mm	1/2"	14	20.40mm
#10 (0.190)	32	4.10mm	1"	12	23.25mm
#12 (0.216)	28	4.70mm	1 1/8"	14	24.00mm
3/16" *	32	4.00mm	1 1/4"	12	26.50mm
1/4"	28	5.50mm	1 3/8"	12	29.50mm
5/16"	24	6.90mm	1 1/2"	12	32.75mm
3/8"	24	8.50mm	1 3/4"	12	36.00mm

*UNS

Pg

Steel Conduit (80°)

Tap Size	TPI	Tapping Drill	Tap Size	TPI	Tapping Drill
Pg7	20	11.30mm	Pg21	16	26.80mm
Pg9	18	13.90mm	Pg29	16	35.50mm
Pg11	18	17.30mm	Pg36	16	45.50mm
Pg13.5	18	19.10mm	Pg42	16	52.50mm
Pg16	18	21.20mm	Pg48	16	57.80mm

BSW

British Standard Whitworth (55°)

Tap Size	TPI	Tapping Drill	Tap Size	TPI	Tapping Drill
1/16" **	60	1.20mm	5/16"	12	12.10mm
3/32" **	48	1.85mm	3/8"	11	13.50mm
1/8"	40	2.55mm	1/2"	10	16.25mm
3/16" **	32	3.20mm	5/8"	9	19.25mm
1/4"	24	3.70mm	1"	8	22.00mm
5/16" **	24	4.50mm	1 1/8"	7	24.75mm
3/8"	20	5.10mm	1 1/4"	7	28.00mm
1/2"	18	6.50mm	1 1/2"	6	33.50mm
5/8"	16	7.90mm	1 3/4"	5	39.00mm
3/4"	14	9.30mm	2"	4 1/2	44.50mm
7/8"	12	10.50mm	2 1/4"	4	51.00mm

* Whit.Form

BSF

British Standard Fine (55°)

Tap Size	TPI	Tapping Drill	Tap Size	TPI	Tapping Drill
3/16"	32	4.00mm	1/16"	14	15.50mm
1/32"	28	4.60mm	3/4"	12	16.75mm
1/4"	26	5.30mm	1/2"	11	19.75mm
5/16"	22	6.80mm	1"	10	22.75mm
3/8"	20	8.30mm	1 1/8"	9	25.50mm
1/2"	18	9.70mm	1 1/4"	9	28.50mm
5/8"	16	11.10mm	1 1/2"	8	34.50mm
3/4"	16	12.70mm	1 3/4"	7	41.00mm
7/8"	14	14.00mm	2"	7	47.00mm

BSPP (Parallel)

British Standard Pipe (55°) RP Series

Tap Size	TPI	Tapping Drill	Tap Size	TPI	Tapping Drill
1/4"	19	11.50mm	1/2"	14	27.75mm
3/8"	19	15.00mm	1"	11	30.25mm
1/2"	14	18.50mm	1 1/4"	11	39.00mm
5/8"	14	20.50mm	1 1/2"	11	45.00mm
3/4"	14	24.00mm	1 3/4"	11	50.50mm

TAPPING DRILL SIZES

All sizes are "suggested sizes" only and may be varied to suit individual requirements



UNEF

Unified National Form (60°)

Tap Size	TPI	Tapping Drill	Tap Size	TPI	Tapping Drill
¼"	32	5.70mm	¾"	24	15.00mm
⅜"	32	7.25mm	1"	20	18.00mm
½"	32	8.85mm	1 1/8"	20	24.30mm
¾"	28	11.80mm	-	-	-

G (BSPF)

ISO G Parallel Series (55°)

Tap Size	TPI	Tapping Drill	Tap Size	TPI	Tapping Drill
G¼"	28	6.80mm	G¼"	14	28.25mm
G½"	28	8.80mm	G1"	11	30.75mm
G¾"	19	11.80mm	G1¼"	11	39.50mm
G1"	19	15.25mm	G1½"	11	45.50mm
G1¼"	14	19.00mm	G1¾"	11	51.00mm
G1½"	14	21.00mm	G2"	11	57.00mm
G1¾"	14	24.50mm	G2½"	11	72.10mm

Rc Series (BSPT)

ISO Rc Taper Series 1:16 (55°)

Tap Size	TPI	Drill Only	Drill & Reamer	Tap Size	TPI	Drill Only	Drill & Reamer
Rc ¼"	28	6.4	6.2	Rc ¾"	14	23.75	23
Rc ½"	28	8.4	8.4	Rc 1"	11	30	29
Rc ¾"	19	11.2	10.8	Rc 1¼"	11	38.5	38
Rc 1"	19	14.75	14.5	Rc 1½"	11	44.5	44
Rc 1¼"	14	18.25	18	Rc 2"	11	56	55

NPT-NPTF

National Pipe Taper 1:16 (60°)

Tap Size	TPI	Drill Only	Drill & Reamer	Tap Size	TPI	Drill Only	Drill & Reamer
¼"	27	6.3	6	¾"	14	23.25	23
½"	27	8.7	8.2	1"	11.5	29	28.5
¾"	18	11.1	10.8	1¼"	11.5	38	37
1"	18	14.5	14	1½"	11.5	44	43.5
1¼"	14	18	17.5	2"	11.5	56	55

BA

47.5°

Tap Size	Pitch	Tapping Drill	Tap Size	Pitch	Tapping Drill
0	0.0394"	1.00mm	9	0.0154"	0.39mm
1	0.0354"	0.90mm	10	0.0138"	0.35mm
2	0.0319"	0.81mm	11	0.0122"	0.31mm
3	0.0287"	0.73mm	12	0.0110"	0.28mm
4	0.0260"	0.66mm	13	0.0098"	0.25mm
5	0.0232"	0.59mm	14	0.0091"	0.23mm
6	0.0209"	0.53mm	15	0.0083"	0.21mm
7	0.0189"	0.48mm	16	0.0075"	0.19mm
8	0.0169"	0.43mm	-	-	-

Rp (BSPP)

Sealing Pipe Thread Parallel (55°)

Tap Size	TPI	Tapping Drill	Tap Size	TPI	Tapping Drill
Rp ¼"	28	8.60mm	Rp 1"	11	30.25mm
Rp ½"	19	11.50mm	Rp 1¼"	11	39.00mm
Rp ¾"	19	15.00mm	Rp 1½"	11	45.00mm
Rp 1"	14	18.50mm	Rp 2"	11	56.50mm
Rp 1¼"	14	24.00mm	-	-	-

NPSF

National Pipe Straight (60°)

Tap Size	TPI	Tapping Drill	Tap Size	TPI	Tapping Drill
¼"	27	8.60mm	¾"	18	14.50mm
½"	18	11.30mm	1"	14	18.00mm

TAPPING DRILL SIZES THREAD FORMING

Thread Forming – Fluteless Taps

Metric Coarse

Tap Size	Pitch	Tapping Drill	Tap Size	Pitch	Tapping Drill
M1	0.25mm	0.90mm	M2.5	0.45mm	2.30mm
M1.1	0.25mm	1.00mm	M2.6	0.45mm	2.40mm
M1.2	0.25mm	1.10mm	M3	0.50mm	2.80mm
M1.4	0.30mm	1.28mm	M3.5	0.60mm	3.20mm
M1.6	0.35mm	1.45mm	M4	0.70mm	3.70mm
M1.7	0.35mm	1.55mm	M5	0.80mm	4.60mm
M1.8	0.35mm	1.65mm	M6	1.00mm	5.50mm
M2.0	0.40mm	1.80mm	M8	1.25mm	7.40mm
M2.2	0.45mm	2.00mm	M10	1.50mm	9.30mm
M2.3	0.40mm	2.10mm	M12	1.75mm	11.20mm

UNF

Tap Size	TPI	Tapping Drill	Tap Size	TPI	Tapping Drill
#1 (0.073)	72	1.70mm	#10 (0.190)	32	4.50mm
#2 (0.086)	64	2.00mm	#12 (0.216)	28	5.10mm
#3 (0.099)	56	2.30mm	¼"	28	6.00mm
#4 (0.112)	48	2.60mm	⅜"	24	7.50mm
#5 (0.125)	44	2.90mm	½"	24	9.00mm
#6 (0.138)	40	3.20mm	⅝"	20	10.60mm
#8 (0.164)	36	3.90mm	¾"	20	12.10mm

UNC

Tap Size	TPI	Tapping Drill	Tap Size	TPI	Tapping Drill
#1 (0.073)	64	1.70mm	#10 (0.190)	24	4.40mm
#2 (0.086)	56	2.00mm	#12 (0.216)	24	5.00mm
#3 (0.099)	48	2.30mm	¼"	20	5.80mm
#4 (0.112)	40	2.60mm	⅜"	18	7.30mm
#5 (0.125)	40	2.90mm	½"	16	8.80mm
#6 (0.138)	32	3.20mm	⅝"	14	10.20mm
#8 (0.164)	32	3.80mm	¾"	13	11.70mm

BSW

Tap Size	TPI	Tapping Drill	Tap Size	TPI	Tapping Drill
¼"	40	2.90mm	¼"	20	5.80mm
⅜"	32	3.60mm	⅜"	18	7.30mm
½"	24	4.30mm	½"	16	8.80mm

G (BSPF)

Tap Size	TPI	Tapping Drill	Tap Size	TPI	Tapping Drill
¼"	28	9.25mm	¾"	14	22.00mm
½"	19	12.50mm	1"	14	25.50mm
¾"	19	16.00mm	1¼"	14	29.25mm
1"	14	20.00mm	1½"	11	32.00mm

The tapping drill sizes indicated are recommended as a guide only. Always check specific sizes as per manufacturer.



THREAD TAP SET, TAP WRENCHES & DIE HOLDERS

7 PIECE THREAD TAP SET – METRIC

- High speed steel
 - Metric coarse intermediate leads
- Includes:**
- Sizes: 3, 4, 5, 6, 8, 10 & 12mm



Item Code	Bishops Code
3020-S1	48640090

TAP WRENCHES



- Straight handle design provides greater leverage
- Useful when working with large diameter taps
- Extra heavy duty
- Industrial quality



Item Code	Capacity	Bishops Code
ARWE/SG/0	M1–M12 ($\frac{1}{8}$ " - $\frac{3}{8}$ ")	48810800
ARWE/SG/5	M4–M16 ($\frac{3}{16}$ " - $\frac{5}{8}$ ")	48810810
ARWR/SG/6	M4–M20 ($\frac{3}{16}$ " - $\frac{7}{8}$ ")	48810820

HAND & CUTTING TOOLS

GET MORE AT BISHOPS



CUTTING FLUID
Page 448

BUTTON DIE HOLDERS

- Knurled handles



Diameter	Bishops Code
1"	48830100
1½"	48830150
2"	48830200

TAPS & DIES

Taps & Dies are tools that are used to cut material to create threads.



Taps used to cut female threads (e.g. a nut) which is called Tapping

A tap cuts a thread on the inside surface of a hole, creating a female thread which functions like a nut. Tapping a hole involves taper taps, intermediate taps and bottoming taps.

Taper Tap – The taper tap features a long tapered edge at the end which causes it to cut more gradually than other taps, allowing for better formed threads. Tapered taps are most commonly used for difficult to work materials. The tap usually begins with 8 to 10 tapered edges.

Intermediate Tap – The intermediate tap features a medium length taper at the end which allows it to align and cut a new thread. The tap usually begins with 3 to 5 tapered edges.

Bottom Tap – This tap is made with a continuous cutting edge with very little to no taper on the end. This allows threading up to the end of a blind hole. A bottoming tap is best suited for finishing a thread that has already been started. The short taper makes this tap insufficient for starting a new taper.

Dies used to cut male threads (e.g. a bolt) which is called Threading

The die cuts a thread along the outside of a cylindrical rod, creating a male thread which functions like a bolt. The cylindrical rod is first machined with a taper at the threaded end to allow the die to be aligned before it is able to cut enough thread to guide itself. Button dies have adjusting screws to expand or compress the die, and are suitable for cutting new threads. Hexagon die nuts should only be used for cleaning and resizing existing damaged threads.

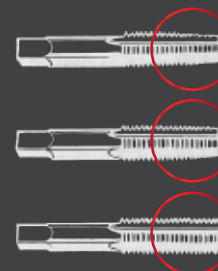

Copper Coring Tube

BUTTON DIES & DIE NUTS – METRIC

- Tungsten chrome alloy – carbon steel
- Die nut – for cleaning and resizing existing damaged threads
- Button die – for cutting new threads

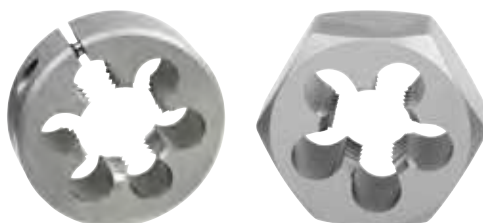

METRIC ISO COARSE		1" BUTTON DIE		1½" BUTTON DIE		2" BUTTON DIE		DIE NUTS	
Size	Pitch	Item Code	Bishops Code	Item Code	Bishops Code	Item Code	Bishops Code	Item Code	Bishops Code
M3	0.50	M4000300	48030030	-	-	-	-	-	-
M4	0.70	M4000400	48030040	-	-	-	-	-	-
M5	0.80	M4000500	48030050	-	-	-	-	M4400500	48060050
M6	1.00	M4000600	48030060	-	-	-	-	M4400600	48060060
M7	1.00	M4000700	48030070	-	-	-	-	M4400700	48060070
M8	1.25	M4000800	48030080	-	-	-	-	M4400800	48060080
M9	1.25	M4000900	48030090	-	-	-	-	M4400900	48060090
M10	1.50	M4001000	48030100	M4011000	48040100	-	-	M4401000	48060100
M12	1.75	M4001200	48030120	M4011200	48040120	M4021200	48050120	M4401200	48060120
M14	2.00	-	-	-	-	-	-	M4401400	48060158
M16	2.00	-	-	-	-	M4021600	48050160	M4401600	48060160
M18	2.50	-	-	-	-	M4021800	48050180	M4401800	48060180
M20	2.50	-	-	-	-	M4022000	48050200	M4402000	48060182
M22	2.50	-	-	-	-	M4022200	48050220	M4402200	48060220
M24	3.00	-	-	-	-	M4022400	48050240	M4402400	48060240
METRIC FINE		1" BUTTON DIE		1½" BUTTON DIE		2" BUTTON DIE		DIE NUTS	
Size	Pitch	Item Code	Bishops Code	Item Code	Bishops Code	Item Code	Bishops Code	Item Code	Bishops Code
M8	1.00	M4030805	48230080	-	48240080	-	-	M4410805	48060075
M10	1.25	M4031006	48230105	M4041006	48240100	-	-	M4411006	48260105
M12	1.25	M4031206	48230120	M4041206	48240125	M4051206	48240142	M4411206	48260120
M12*	1.50	M4031207	48230125	M4041207	48240120	M4051207	48240143	M4411207	48260125
M14	1.25	-	-	M4041406	48240140	M4051406	48240144	-	-
M14	1.50	-	-	M4041407	48240141	M4051407	48250145	M4411407	48260145
M16	1.50	-	-	-	-	M4051607	48250160	M4411607	48260160
M18	1.50	-	-	-	-	M4051807	48250180	M4411807	48260180
M20	1.50	-	-	-	-	M4052007	48250200	M4412007	48260181
M22	1.50	-	-	-	-	M4052207	48250220	-	-
M24	2.00	-	-	-	-	M4052408	48250221	-	-

BUTTON DIES & DIE NUTS – UNC

- Tungsten chrome alloy – carbon steel
- Die nut – for cleaning and resizing existing damaged threads
- Button die – for cutting new threads



		1" BUTTON DIE		1½" BUTTON DIE		2" BUTTON DIE		DIE NUTS	
Size	TPI	Item Code	Bishops Code	Item Code	Bishops Code	Item Code	Bishops Code	Item Code	Bishops Code
¼"	20	M4120635	47430300	-	-	-	-	M4450635	47460300
⅝ ₁₆ "	18	M4120794	47430320	-	-	-	-	M4450794	47460320
⅜"	16	M4120953	47430340	-	-	-	-	M4450953	47460340
7 ₁₆ "	14	M4121111	47430360	-	-	-	-	M4451111	47460360
½"	13	M4121270	47430380	M4131270	47440380	M4141270	47450380	M4451270	47460380
9 ₁₆ "	12	-	-	-	-	M4141429	47450400	M4451429	47460400
⅝"	11	-	-	M4131588	47440420	M4141588	47450420	M4451588	47460420
¾"	10	-	-	-	-	M4141905	47450460	M4451905	47460460
7 ₈ "	9	-	-	-	-	M4142223	47450470	M4452223	47460500
1"	8	-	-	-	-	M4142540	47450540	M4452540	47460520
1⅝"	7	-	-	-	-	-	-	M4452858	47460521
1¼"	7	-	-	-	-	-	-	M4453175	47460522
1½"	6	-	-	-	-	-	-	M4453810	47460523



BUTTON DIES, DIE NUTS & TAP & DRILL SETS

BUTTON DIES & DIE NUTS – UNF

- Tungsten chrome alloy – carbon steel
- Die nut – for cleaning and resizing existing damaged threads
- Button die – for cutting new threads

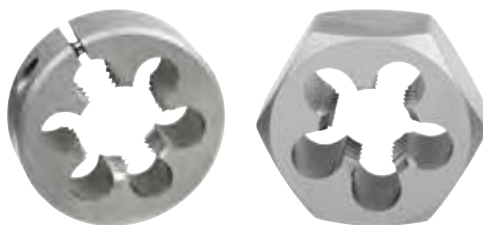

HAND & CUTTING TOOLS

Size	TPI	1" BUTTON DIE		1½" BUTTON DIE		2" BUTTON DIE		DIE NUTS	
		Item Code	Bishops Code	Item Code	Bishops Code	Item Code	Bishops Code	Item Code	Bishops Code
¼"	28	M4150635	47630300	M4160635	47640300	–	–	M4460635	47660300
5/16"	24	M4150794	47630320	M4160794	47640320	–	–	M4460794	47660320
3/8"	24	M4150953	47630340	M4160953	47640340	–	–	M4460953	47660340
7/16"	20	M4151111	47630360	M4161111	47640360	–	–	M4461111	47660360
½"	20	M4151270	47630380	M4161270	47640380	M4171270	47650380	M4461270	47660380
9/16"	18	–	–	M4161429	47640400	–	–	M4461429	47660400
5/8"	18	–	–	M4161588	47640420	M4171588	47650420	M4461588	47660420
¾"	16	–	–	–	–	M4171905	47650460	M4461905	47660460
7/8"	14	–	–	–	–	M4172223	47650500	M4462223	47660500
1"	12	–	–	–	–	M4172540	47650540	M4462540	47660520

14 PIECE TAP & DRILL SET – METRIC

- High speed steel
- Metric coarse intermediate
- Used for machine and hand tap applications

Includes:

- 7 x Taps – 3, 4, 5, 6, 8, 10 & 12mm
- 7 x Drills to suit



Item Code	Bishops Code
3020-S2	48640110

14 PIECE TAP & DRILL SET – METRIC

- High speed steel
- Intermediate taps and tapping drills

Includes:

- 7 x Taps – M3, M4, M5, M6, M8, M10 & M12
- 7 x Drills – 2.5, 3.3, 4.2, 5.0, 6.8, 8.5 & 10.2mm



Item Code	Bishops Code
T3850014	48640116

ALWAYS USE LUBE

Quality, Application, Cleanliness



Threading Quality

To ensure that you make the highest of quality threads, it's important that you use lube for any tapping or threading. A solid quality thread can sometimes be determined by your choice of lube, so be sure to explore your options to find the best suit.

Lubricant Choice

In general application, extreme pressure additives are greatly suited for hard materials. Cutting lubricants stick to the surface to help provide friction during tapping and threading tough materials. They also control and dispose of the metal chips that are produced during the process.

Lubricant Application

Not only must the right lubricant be selected, but it also has to be used correctly. You won't get anywhere with just a drop of lube if you're doing a big job. Be sure that lubricant is always in place where the metal is being cut during the whole process, not just at the start.

Lubricant Cleanliness

When using lubricants, make sure that they are always clean by either using new lubricant or filters. Dirty lube can cause damage to your tool and ruin the finish of your threads.

18 PIECE TAP & DIE SET – IMPERIAL

- Imperial UNC
- Plastic case
- ¼"–½"
- Includes:**
- 8 x Thread taps
- 8 x Button dies
- 1 x Tap wrench
- 1 x Die holder



Bishops Code
48610020

24 PIECE TAP & DIE SET – IMPERIAL

- Imperial UNC/UNF
- Metal case
- ¼"–½"
- Includes:**
- 11 x Thread taps
- 11 x Button dies
- 1 x Bar type tap wrench
- 1 x Die holder



Bishops Code
48650020

28 PIECE TAP & DIE SET – METRIC

- Metric
- Metal case
- 3–12mm
- Includes:**
- 16 x Thread taps
- 8 x Button dies
- 1 x Die holder
- 1 x Bar type tap wrench
- 1 x T-type tap wrench
- 1 x Screw pitch gauge



Bishops Code
48640020

45 PIECE TAP & DIE SET – IMPERIAL

- Imperial UNC/UNF
- High speed steel
- Plastic case
- ¼"–1"
- Includes:**
- 20 x Thread taps
- 20 x Button dies
- 1 x Die holder and adaptor
- 1 x Bar type tap wrench
- 1 x T-type tap wrench
- 1 x Screwdriver



Bishops Code
48650060

TAP & DIE SETS – METRIC & IMPERIAL

- High grade carbon



Item Code	Description	Tap Range	Die Range	Tap Wench	Die Holder	Bishops Code
M500M35	35 Piece Set – Metric Coarse	M6–M24	M6–M24	#0 & #7	1" & 2"	48640120
M500NC35	35 Piece Set – UNC	¼"–1"	¼"–1"	#0 & #7	1" & 2"	48610080
M500NFM52	52 Piece Set – UNF/Metric Coarse	¼"–¾"	¼"–¾"	#6	1" & 2"	48650570

TAP & DIE SETS – METRIC & IMPERIAL

- Great value, high quality sets
- Include various combinations of metric, imperial and SAE taps and button dies
- Manufactured from premium quality tungsten steel
- Supplied in a tough, compact, blow moulded case



48640035

48640040



48640115

48650030
48640030

Item Code	Description	Bishops Code
50-S1	115 Piece Metric & Imperial – Includes: 48 Intermediate Lead Taps, 48 Button Dies, Die Holders, Tap Wrenches, Screw Extractors & More	48640040
50-S2	60 Piece Metric & SAE + ¼" NPT – Includes: 27 Intermediate Lead Taps, 27 Button Dies, Die Holder, Tap Wrenches, Pitch Gauges & More	48640035
50-S3	39 Piece UNC/UNF + ¼" NPT – Includes: 17 Intermediate Lead Taps, 17 Button Dies, Die Holder, Tap Wrenches, Pitch Gauge & More	48650030
50-S4	39 Piece Metric + ¼" NPT – Includes: 17 Intermediate Lead Taps, 17 Button Dies, Die Holder, Tap Wrenches, Pitch Gauge & More	48640030
50-S5	14 Piece Metric Coarse – Includes: 7 Straight Flute Intermediate Taps – M3–M12 & Matching HSS Tapping Drills	48640115



PIPE DIE SETS & PIPE THREADING MACHINES

HAND & CUTTING TOOLS

4 PIECE PIPE DIE SET – IMPERIAL

- Manual pipe threader
 - Drop head threader
 - BSPT
 - Capacity: ½”–1¼”
- Includes:**
- 4 x Heads
 - 1 x Ratchet



Item Code	Bishops Code
63022	48660500

10 PIECE PIPE DIE SET – IMPERIAL

- BSPT Master kit 2
 - Capacity: ½”–2”
- Includes:**
- Pipe wrench
 - Pipe cutter
 - Box joint pliers
 - Ratchet



Item Code	Bishops Code
69052	48660590

6 PIECE PIPE DIE SET – IMPERIAL

- Manual pipe threader
 - Drop head threader
 - BSPT
 - Capacity: ½”–2”
- Includes:**
- 6 x Heads
 - 1 x Ratchet



Item Code	Bishops Code
63132	48660550

MASTERMATIC 2 ELECTRIC PIPE THREADER SET

- Compact and easy to use threading machine
 - Provides easy access to hard-to-reach places
 - The design of the enlarged heads creates smooth and better threading
 - Ductile casting and special steel dies with an aluminium cover
 - Steel hardness: 58–62HRc
 - Capacity: ¼”–2”
- Includes:**
- 8 x Heads



Item Code	Bishops Code
69116	75590050

7 PIECE PIPE DIE SET – IMPERIAL

- BSPT Master kit 1
 - Capacity: ½”–1”
- Includes:**
- Pipe wrench
 - Pipe cutter
 - Box joint pliers
 - Ratchet



Item Code	Bishops Code
69001	48660580

ROSCAMATIC 80-3 ELECTRIC PIPE THREADER

- Designed to thread, cut and ream water, gas or oil conduction pipes
- Fitted with an automatic threading copy system, allowing the machine to produce conical threads automatically once the length is set by the norms
- The induction motor does not lose speed and provides a smoother and quieter operation
- Self-lubricating circuit
- BSPT type
- 750W
- 230V, 50–60Hz
- Up to 24rpm
- Capacity: ½”–3”
- Weight: 114kg



Item Code	Description	Bishops Code
56955	Pipe Threader	75590150
64150	1–2” BSPT Pipe Die to Suit	75595098

POWERCOIL® THREAD REPAIR KITS



UNC					
Item Code	Size x TPI	Bishops Code	Item Code	Size x TPI	Bishops Code
3532-1/4K	1/4" x 20	40802040	3532-5/8K	5/8" x 11	40802090
3532-5/16K	5/16" x 18	40802050	3532-3/4K	3/4" x 10	40802100
3532-3/8K	3/8" x 16	40802060	3532-7/8K	7/8" x 9	40802110
3532-7/16K	7/16" x 14	40802070	3532-1K	1" x 8	40802120
3532-1/2K	1/2" x 13	40802080	3532-1.1/4K	1 1/4" x 7	40802130

UNF					
Item Code	Size x TPI	Bishops Code	Item Code	Size x TPI	Bishops Code
3534-10GK	10G" x 32	40804030	3534-1/2K	1/2" x 20	40804080
3534-1/4K	1/4" x 28	40804040	3534-5/8K	5/8" x 18	40804090
3534-5/16K	5/16" x 24	40804050	3534-3/4K	3/4" x 16	40804100
3534-3/8K	3/8" x 24	40804060	3534-7/8K	7/8" x 14	40804110
3534-7/16K	7/16" x 20	40804070	3534-1K	1" x 12	40804120

METRIC					
Item Code	Size x Pitch	Bishops Code	Item Code	Size x Pitch	Bishops Code
3520-4.00K	M4 x 0.70mm	40810030	3521-14.00K	M14 x 1.50mm	40810140
3520-5.00K	M5 x 0.80mm	40810040	3520-14.00K	M14 x 2.00mm	40810150
3520-6.00K	M6 x 1.00mm	40810050	3521-16.00K	M16 x 1.50mm	40810160
3520-8.00K	M8 x 1.25mm	40810060	3520-16.00K	M16 x 2.00mm	40810170
3522-10.00K	M10 x 1.00mm	40810070	3522-18.00K	M18 x 1.50mm	40810180
3521-10.00K	M10 x 1.25mm	40810080	3520-18.00K	M18 x 2.50mm	40810190
3520-10.00K	M10 x 1.50mm	40810090	3521-20.00K	M20 x 2.00mm	40810195
3522-12.00K	M12 x 1.25mm	40810100	3520-20.00K	M20 x 2.50mm	40810200
3521-12.00K	M12 x 1.50mm	40810110	3523-22.00K	M22 x 1.50mm	40810205
3520-12.00K	M12 x 1.75mm	40810120	3523-24.00K	M24 x 1.50mm	40810207
3522-14.00K	M14 x 1.25mm	40810130	3521-24.00K	M24 x 2.00mm	40810210

POWERCOIL® THREAD INSERT KITS

• Metric/UNC



Item Code	Size	Bishops Code
3520-WK1	5-12mm	40880300
3520-WK3	6-16mm	40880400

POWERCOIL® INSERTS



UNC				
Item Code	Size x TPI	Insert Length (Installed)	Qty	Bishops Code
3532-10GX1.5DP	3/16" x 24	1.5 x Dia.	10	40822030
3532-1/4X1.5DP	1/4" x 20	1.5 x Dia.	10	40822040
3532-5/16X1.5DP	5/16" x 18	1.5 x Dia.	10	40822050
3532-3/8X1.5DP	3/8" x 16	1.5 x Dia.	10	40822060
3532-7/16X1.5DP	7/16" x 14	1.5 x Dia.	10	40822070
3532-1/2X1.5DP	1/2" x 13	1.5 x Dia.	10	40822080
3532-9/16X1.5DP	9/16" x 12	1.5 x Dia.	10	40822085
3532-5/8X1.0DP	5/8" x 11	1.0 x Dia.	5	40822090
3532-5/8X1.5DP	5/8" x 11	1.5 x Dia.	5	40822092
3532-3/4X1.5DP	3/4" x 10	1.5 x Dia.	5	40822100
3532-7/8X1.5DP	7/8" x 9	1.5 x Dia.	5	40822110
3532-1X1.5DP	1" x 8	1.5 x Dia.	5	40822120
3532-1.1/4X1.5DP	1 1/4" x 7	1.5 x Dia.	5	40822130

METRIC				
Item Code	Size x Pitch	Insert Length (Installed)	Qty	Bishops Code
3520-4.00X1.5DP	M4 x 0.70mm	1.5 x Dia.	10	40830030
3520-5.00X1.5DP	M5 x 0.80mm	1.5 x Dia.	10	40830040
3520-6.00X1.5DP	M6 x 1.00mm	1.5 x Dia.	10	40830050
3520-8.00X1.5DP	M8 x 1.25mm	1.5 x Dia.	10	40830060
3521-10.00X1.5DP	M10 x 1.25mm	1.5 x Dia.	10	40830080
3520-10.00X1.5DP	M10 x 1.50mm	1.5 x Dia.	10	40830090
3523-12.00X1.5DP	M12 x 1.25mm	1.5 x Dia.	10	40830100
3521-12.00X1.5DP	M12 x 1.50mm	1.5 x Dia.	10	40830110
3520-12.00X1.5DP	M12 x 1.75mm	1.5 x Dia.	10	40830120
3522-14.00x3/8P	M14 x 1.25mm	3/8" Dia.	10	40830130
3522-14.00X1/2P	M14 x 1.25mm	1/2" Dia.	10	40830132
3521-14.00X1.5DP	M14 x 1.50mm	1.5 x Dia.	5	40830140
3520-16.00X1.5DP	M16 x 2.00mm	1.5 x Dia.	5	40830170
3523-18.00X1.0DP	M18 x 1.50mm	1.0 x Dia.	5	40830180
3521-20.00X1.5DP	M20 x 2.00mm	1.5 x Dia.	3	40830190
3520-20.00X1.5DP	M20 x 2.50mm	1.5 x Dia.	3	40830200
3520-24.00X1.5DP	M24 x 3.0mm	1.5 x Dia.	3	40830240

EXTERNAL THREAD FILES

- Restores damaged threads
- For left or right handed external threads
- Metric and imperial options



Item Code	Description	Bishops Code
SCMT70449	Imperial	49895140
SCMT70450	Metric	49895160

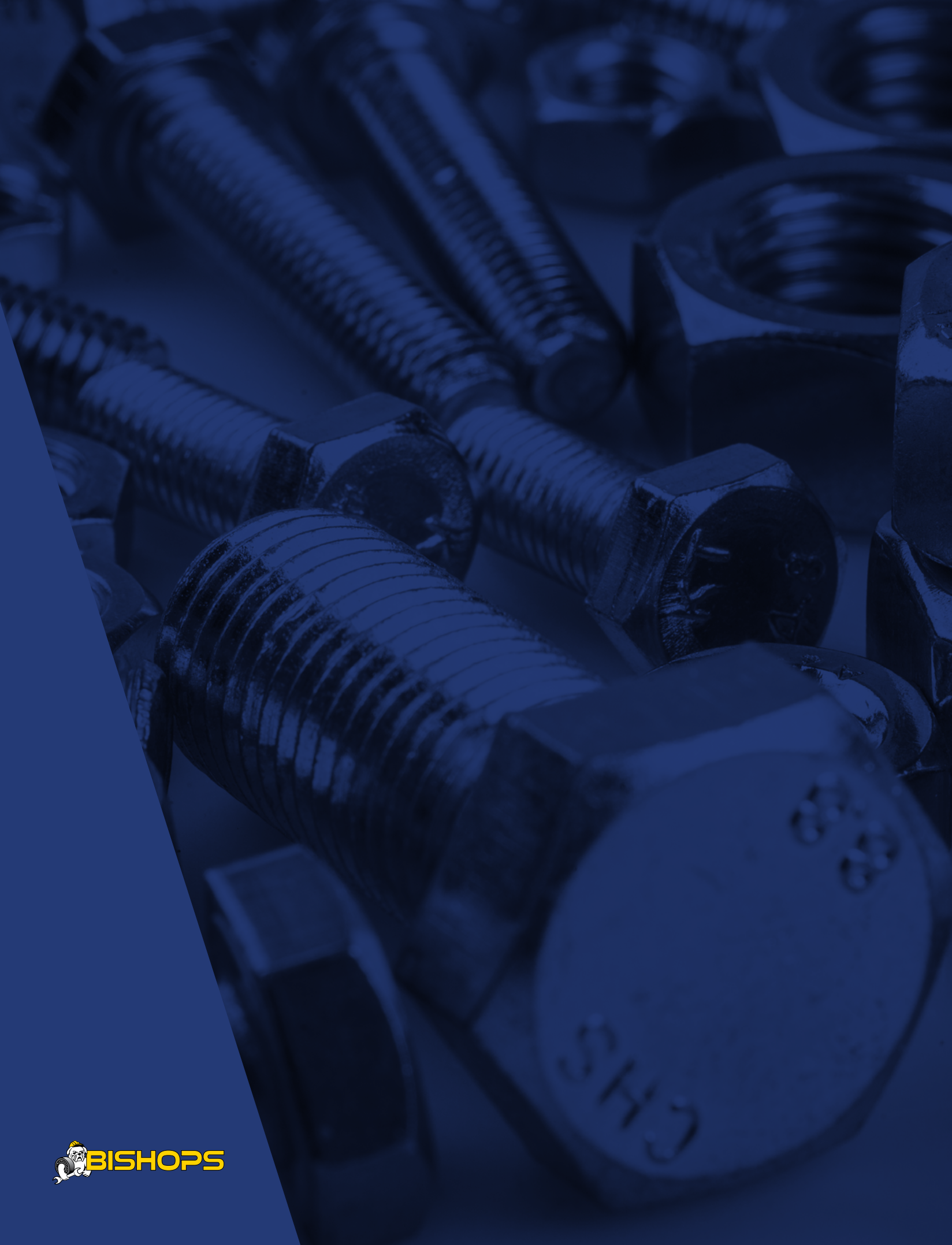

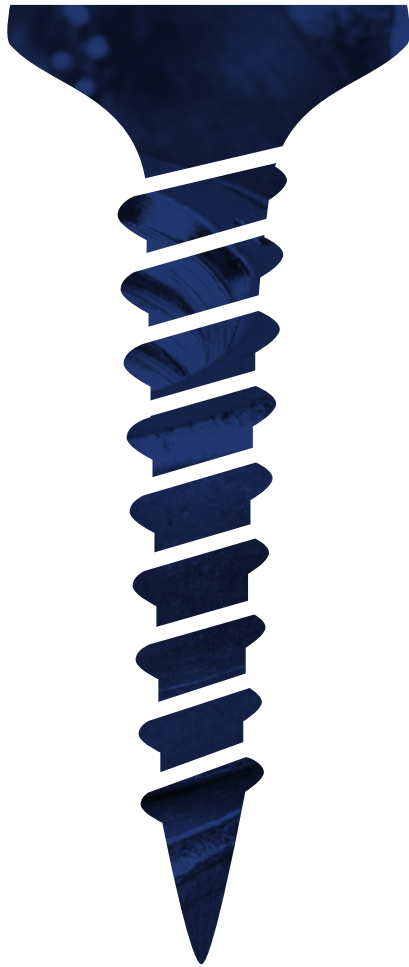

06 FASTENERS

BOLTS & NUTS

Hex Head Bolts	279–281
Set Screws	281
Hex Nuts	283
Locknuts	284

WASHERS

Flat Round Washers	285
Spring Washers	285
Nord-Lock Washers	285

SCREWS

Socket Head Screws	286–287
Grub Screws	287
Allthread	288

CONSTRUCTION FASTENERS

Sleeve Anchors	289
Chemical Anchors	289

ASSORTMENT KITS

Assortment & Master Kits	289–290
Washers Kits	290–291
Cap Screw & Self-Tapping Screw Kits	291–292
Grub Screw Kits	292
Rivet Kits	292–293
Pins & Clips Kits	293



FASTENERS 101 – YOUR GUIDE TO THE SECTION



Fasteners are easy at Bishops.

This information will guide you through this section and explain our naming and colouring conventions. We offer a full range of materials and finishes to suit every application.

Class 12.9	Class 10.9 Grade 8	Class 8.8 Grade 5	Grade 304 Stainless	Grade 316 Stainless	Class 4.6 Grade 2
------------	-----------------------	----------------------	------------------------	------------------------	----------------------

Class/Grade

The strength of a fastener is expressed in the metric system as Class, and in the imperial system as Grade.

Class 10.9, 12.9/Grade 8:

High tensile. These classes provide considerably higher clamping strength and are more resilient.

Class 8.8/Grade 5:

High tensile (medium strength).

Class 4.6/Grade 2:

Low tensile (mild steel). Economical and readily available. Also known as commercial bolts.

Grade 304/Grade 316:

Stainless steel. Generally tensile strength is just above that of low tensile steel although alloys are available with greater strength.

Finish

Zinc Plated Electro-plated in a slightly blue-ish or yellow coating for corrosion resistance. Best employed in indoor or mild outdoor conditions, as rust will break through the coating if exposed to marine environments.

Black Also known as plain or self-colour. Offers no real corrosion protection when in use. Can be welded and grinded.

Galvanised The coating choice for superior corrosion resistance. Thickness of coating means galvanised bolts will only interface with galvanised nuts.

Stainless Good corrosion resistance, suitable for outdoor use and marine applications. More costly than zinc plated. Available in different grades.

TIP: If you can't find what you're looking for, just give us a call and we'll find it for you.

Breaking Strength Comparison Chart

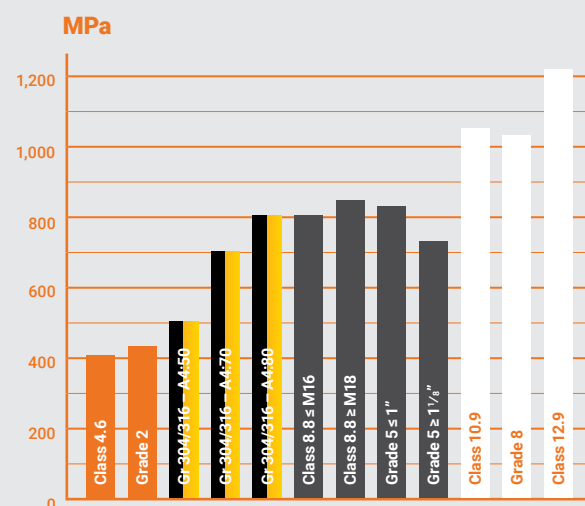

CLASS 8.8 HIGH TENSILE BOLTS – METRIC COARSE

- Hex head
- Black finish
- Standards: AS/NZS 1110 – ISO 4014/4017



Dia.	M5	M6	M8	M10	M12	M14	M16	M18	M20	M22	M24	M30
Length	Bishops Code											
12mm	44405012	44406012	-	-	-	-	-	-	-	-	-	-
16mm	-	44406016	44408016	-	-	-	-	-	-	-	-	-
20mm	44405020	44406020	44408020	44410020	44412020	-	-	-	-	-	-	-
25mm	44405025	44406025	44408025	44410025	44412025	44414025	-	-	-	-	-	-
30mm	44405030	44406030	44408030	44410030	44412030	44414030	44416030	44418030	-	-	-	-
35mm	44405035	44406035	44408035	44410035	44412035	44414035	44416035	-	-	-	-	-
40mm	44405040	44406040	44408040	44410040	44412040	44414040	44416040	44418040	44420040	-	-	-
45mm	-	44406045	44408045	44410045	44412045	-	44416045	-	44420045	-	-	-
50mm	44405050	44406050	44408050	44410050	44412050	44414050	44416050	44418050	44420050	44422050	44424050	-
55mm	-	-	-	44410055	44412055	-	44416055	44418055	44420055	44422055	-	-
60mm	-	44406060	44408060	44410060	44412060	44414060	44416060	44418060	44420060	44422060	44424060	-
65mm	-	44406065	44408065	44410065	44412065	-	44416065	-	44420065	44422065	44424065	-
70mm	-	44406070	44408070	44410070	44412070	44414070	44416070	44418070	44420070	44422070	44424070	-
75mm	-	44406075	44408075	44410075	44412075	44414075	44416075	44418075	44420075	44422075	44424075	44430075
80mm	-	44406080	44408080	44410080	44412080	44414080	44416080	44418080	44420080	44422080	44424080	44430080
85mm	-	-	-	-	44412085	-	-	-	-	-	44424085	-
90mm	-	44406090	44408090	44410090	44412090	44414090	44416090	44418090	44420090	44422090	44424090	44430090
100mm	-	-	44408100	44410100	44412100	44414100	44416100	44418100	44420100	44422100	44424100	-
110mm	-	-	-	44410110	44412110	44414110	44416110	-	44420110	44422110	44424110	44430110
120mm	-	-	44408120	44410120	44412120	44414120	44416120	-	44420120	44422120	44424120	-
125mm	-	-	-	-	-	-	-	-	-	-	44424125	-
130mm	-	-	-	-	44412130	44414130	44416130	-	44420130	44422130	44424130	-
140mm	-	-	-	44410140	44412140	44414140	44416140	44418140	44420140	44422140	44424140	-
150mm	-	-	-	44410150	44412150	44414150	44416150	44418150	44420150	44422150	44424150	44430150
160mm	-	-	-	-	44412160	-	-	44418160	-	-	44424160	44430160
165mm	-	-	-	-	-	-	-	-	-	-	-	-
170mm	-	-	-	-	-	-	44416170	-	-	-	-	44430170
180mm	-	-	-	-	44412180	-	44416180	44418180	-	-	-	-
200mm	-	-	-	-	-	-	44416200	44418200	44420200	-	44424200	44430200
250mm	-	-	-	-	-	-	-	-	44420250	44422250	44424250	-
260mm	-	-	-	-	-	-	-	-	44420260	-	-	-
300mm	-	-	-	-	-	-	-	-	-	-	-	44430300
Pitch	0.80mm	1.00mm	1.25mm	1.50mm	1.75mm	2.00mm	2.00mm	2.50mm	2.50mm	2.50mm	3.00mm	3.50mm
Wrench	8mm	10mm	13mm	16mm	18mm	21mm	24mm	27mm	30mm	32mm	36mm	46mm

CLASS 8.8 HIGH TENSILE BOLTS – METRIC FINE

- Hex head
- Black finish
- ISO 8765/1999



Diameter	M10	M12-1.50mm	M12-1.25mm	M14	M16	M18	M20 – 2.0mm
Length	Bishops Code						
35mm	-	-	-	44614035	-	-	-
40mm	-	44612040	44612042	44614040	44616040	-	-
50mm	-	44612050	44612055	44614050	44616050	-	-
60mm	-	-	-	44614060	44616060	-	-
65mm	-	-	-	-	-	-	-
70mm	-	-	-	-	-	-	-
75mm	-	44612075	-	-	44616075	-	-
80mm	-	-	-	-	-	-	-
90mm	-	-	-	-	-	-	-
100mm	-	44612100	-	-	-	-	-
Pitch	1.25mm	1.50mm	1.25mm	1.50mm	1.50mm	1.50mm	2.0mm
Wrench	16mm	18mm	18mm	21mm	24mm	27mm	30mm



HEX HEAD BOLTS

GRADE 8 HIGH TENSILE BOLTS – IMPERIAL UNC

- Hex head
- Black finish
- AS/NZS 2465/1999
- ANSI B18.2.1 1996

FASTENERS



Dia.	¼" UNC	5/16" UNC	¾" UNC	7/16" UNC	½" UNC	9/16" UNC	5/8" UNC	¾" UNC	7/8" UNC	1" UNC
Length	Bishops Code									
½"	44030005	–	44034005	–	–	–	–	–	–	–
¾"	44030007	44032007	44034007	–	44038007	–	–	–	–	–
1"	44030010	44032010	44034010	44036010	44038010	44040010	44042010	–	–	–
1¼"	44030012	44032012	44034012	44036012	44038012	–	–	44046012	–	–
1½"	44030015	44032015	44034015	44036015	44038015	44040015	44042015	44046015	–	–
1¾"	44030017	44032017	44034017	44036017	44038017	44040017	44042017	44046017	–	–
2"	44030020	44032020	44034020	44036020	44038020	44040020	44042020	44046020	44050020	44054020
2¼"	–	44032022	44034022	–	44038022	–	–	44046022	–	–
2½"	44030025	44032025	44034025	44036025	44038025	44040025	44042025	44046025	44050025	44054025
2¾"	–	–	44034027	–	–	–	–	44046027	–	–
3"	44030030	44032030	44034030	44036030	44038030	44040030	44042030	44046030	44050030	44054030
3¼"	–	–	–	–	–	–	–	–	–	–
3½"	44030035	44032035	44034035	44036035	44038035	44040035	44042035	44046035	–	44054035
3¾"	–	–	–	–	–	–	–	–	–	–
4"	44030040	44032040	44034040	44036040	44038040	44040040	44042040	44046040	44050040	44054040
4½"	44030045	44032045	44034045	44036045	44038045	–	44042045	44046045	44050045	44054045
5"	–	44032050	44034050	44036050	44038050	44040050	44042050	44046050	44050050	44054050
5½"	–	–	44034055	–	44038055	–	44042055	–	44050055	44054055
6"	–	44032060	44034060	44036060	44038060	44040060	44042060	44046060	44050060	44054060
6¼"	–	–	–	–	–	–	–	–	–	–
6½"	–	–	–	–	44038065	–	44042065	44046065	–	–
7"	–	–	–	–	44038070	–	44042070	44046070	–	–
7½"	–	–	–	–	–	–	–	–	–	–
8"	–	–	–	–	44038080	–	44042080	44046080	–	44054080
9"	–	–	–	–	–	–	–	–	–	44054090
9½"	–	–	–	–	–	–	–	–	–	–
10"	–	–	–	–	–	–	–	44046100	–	–
Pitch	20	18	16	14	13	12	11	10	9	8
Wrench	7/16"	½"	9/16"	11/16"	¾"	7/8"	15/16"	1"	1 1/16"	1 1/2"

SCREW HEAD DRIVE STYLES

Phillips: Extremely common. Designed to cam out with excessive torque, which can round off the edges and make removal difficult.



Pozidriv: Visually similar to phillips but with a second set of indentations set at 45° that discourage slipping and cam out. Only use pozidriv bits in pozidriv heads.



Slotted: The original screw drive. Take care that the driver does not slip out and cause injury.



Square: Otherwise called robertson drive. Self-centering, won't cam out, allows for high torque.



Hex: Drives with an Allen key or a hex driver bit. Won't cam out, allows for high torque.



Each driver type has advantages and disadvantages, so choose carefully based on your application.

GET MORE AT BISHOPS



ADJUSTABLE WRENCHES

Page 198

GRADE 8 HIGH TENSILE BOLTS – IMPERIAL UNF

- Hex head
- Black finish
- AS/NZS 2465/1999
- ANSI B18.2.1 1996



Dia.	1/4" UNF	5/16" UNF	3/8" UNF	7/16" UNF	1/2" UNF	9/16" UNF	5/8" UNF	3/4" UNF
Length	Bishops Code							
3/4"	44230007	44232007	–	–	–	–	–	–
1"	44230010	44232010	44234010	44236010	44238010	–	–	–
1 1/4"	44230012	44232012	44234012	–	–	–	–	–
1 1/2"	44230015	44232015	44234015	44236015	44238015	44240015	44242015	44246015
1 3/4"	–	44232017	–	–	–	–	–	–
2"	44230020	44232020	44234020	44236020	44238020	44240020	44242020	44246020
2 1/4"	–	44232022	–	–	–	–	–	–
2 1/2"	44230025	44232025	44234025	44236025	44238025	44240025	44242025	44246025
2 3/4"	–	–	–	–	–	–	–	–
3"	44230030	44232030	44234030	44236030	44238030	44240030	44242030	44246030
3 1/4"	–	–	–	–	–	–	–	–
3 1/2"	44230035	44232035	44234035	44236035	44238035	44240035	44242035	44246035
4"	44230040	44232040	44234040	44236040	44238040	44240040	44242040	44246040
4 1/2"	–	–	–	–	44238045	–	44242045	44246045
5"	–	–	44234050	44236050	44238050	44240050	44242050	44246050
5 1/2"	–	–	–	–	44238055	–	44242055	44246055
6"	–	–	–	–	44238060	44240060	44242060	44246060
6 1/2"	–	–	–	–	–	–	44242065	–
7"	–	–	–	–	–	–	44242070	44246070
7 1/2"	–	–	–	–	–	–	–	44246075
8"	–	–	–	–	–	–	44242080	44246080
9"	–	–	–	–	–	–	44242090	–
TPI	28	24	24	20	20	18	18	16
Wrench	7/16"	1/2"	9/16"	1 1/16"	3/4"	7/8"	1 1/16"	1 1/8"

FASTENER FACTS

What's the difference between shear stress and tensile stress?

Check page 289 for the answer!

GRADE 316 STAINLESS STEEL HEX HEAD BOLTS – METRIC COARSE

- DIN 931



Diameter	M16	Diameter	M16
Length	Bishops Code	Length	Bishops Code
50mm	42316050	90mm	42316090
60mm	42316060	100mm	42316100
70mm	42316070	–	–
Pitch	2.0mm	Pitch	2.0mm
Wrench	24mm	Wrench	24mm

GRADE 316 STAINLESS STEEL SET SCREWS – METRIC COARSE

- Hex head



Diameter	M5	M6	M8	M10	M12
Length	Bishops Code				
12mm	–	42306012	–	–	–
15mm	–	–	42308015	–	–
20mm	42305020	42306020	–	–	–
25mm	42305025	42306025	42308025	42310025	42312025
30mm	42305030	42306030	42308030	42310030	42312030
35mm	–	42306035	42308035	42310035	42312035
40mm	42305040	42306040	42308040	42310040	42312040
45mm	–	42306045	42308045	42310045	42312045
50mm	42305050	42306050	42308050	42310050	42312050
55mm	–	–	42308055	–	–
60mm	–	42306060	42308060	42310060	42312060
65mm	–	42306065	42308065	–	–
70mm	–	42306070	42308070	42310070	42312070
75mm	–	42306075	–	–	42312075
80mm	–	42306080	42308080	42310080	42312080
90mm	–	–	–	42310090	42312090
100mm	–	42306100	42308100	42310100	42312100
120mm	–	–	–	42310120	–
Pitch	0.80mm	1.00mm	1.25mm	1.50mm	1.75mm
Wrench	8mm	10mm	13mm	16mm	18mm



THREAD PITCH & TPI

Use this conversion table to compare the thread pitch and TPI of common fastener thread forms in metric and imperial.

Metric	Pitch (mm)			Imperial	Threads Per Inch (TPI)				
	Coarse	Fine	Extra Fine		UNC	UN8	UNF	BSW	BSF
M1.6	0.35	-	-	#0	-	-	80	-	-
M2	0.4	-	-	#1	-	-	72	-	-
-	-	-	-	#2	56	-	64	-	-
M2.5	0.45	-	-	#3	48	-	56	-	-
-	-	-	-	#4	40	-	48	-	-
M3	0.5	-	-	1/8" (#5)	40	-	44	40	-
M3.5	0.6	-	-	#6	32	-	40	-	-
M4	0.7	-	-	#8	32	-	36	-	-
M5	0.8	-	-	3/16" (#10)	24	-	32	24	32
-	-	-	-	#12	24	-	28	-	-
M6	1	-	-	1/4"	20	-	28	20	26
M8	1.25	1	-	5/16"	18	-	24	18	22
M10	1.5	1.25	1	3/8"	16	-	24	16	20
-	-	-	-	7/16"	14	-	20	14	18
M12	1.75	1.5	1.25	1/2"	13	-	20	12	16
M14	2	1.5	-	9/16"	12	-	18	12	16
M16	2	1.5	-	5/8"	11	-	18	11	14
M18	2.5	1.5	-	-	-	-	-	-	-
M20	2.5	1.5	-	3/4"	10	-	16	10	12
M22	2.5	1.5	-	7/8"	9	-	14	9	11
M24	3	2	-	1"	8	8	12(14)	8	10
M27	3	2	-	1 1/8"	7	8	12	7	9
M30	3.5	2	-	1 1/4"	7	8	12	7	9
M33	3.5	2	-	1 3/8"	6	8	12	6	8
M36	4	3	-	1 1/2"	6	8	12	6	8
M39	4	3	-	1 5/8"	-	8	-	5	8
M42	4.5	-	-	-	-	-	-	-	-
M45	4.5	-	-	1 3/4"	5	8	-	5	7
M48	5	-	-	1 7/8"	-	8	-	-	-
M52	5	-	-	2	4.5	8	-	4.5	7
M56	5.5	-	-	2 1/4"	4.5	8	-	4	6
M60	5.5	-	-	-	-	-	-	-	-
M64	6	-	-	2 1/2"	4	8	-	4	6
M72	6	-	-	2 3/4"	4	8	-	3.5	6
M80	6	-	-	3"	4	8	-	3.5	5
-	-	-	-	3 1/4"	4	8	-	3.25	5
M90	6	-	-	3 1/2"	4	8	-	3.25	4.5
-	-	-	-	3 3/4"	4	8	-	3	4.5
M100	6	-	-	4"	4	8	-	3	4.5



FASTENER FACTS

Did you know?

A phone is held together with about 75 fasteners, a car with 3,500, and a jet plane with 1,500,000.

FASTENER MARKINGS

Different classes and grades of bolts and nuts can be marked to allow easy identification. Find out what you're looking at with this handy guide.

Metric Markings

The 1st number is the minimum tensile strength in MPa i.e. Class 8.8 = 800MPa

The 2nd number is the yield strength. In the case of an 8.8 bolt, this means the fastener will begin to yield at 80% of the tensile strength, or at least 640MPa.

Metric class for high tensile bolts is generally stamped on the head along with manufacturer's mark. Simple!

Imperial Markings

Grade 5 bolts will have 3 radial lines stamped on the head.

Grade 8 bolts will have 6 radial lines stamped on the head.

A simple rule – the number of lines on the head **plus two** equals the grade.



FASTENER SPECIALISTS

If you can't find what you're looking for, just give Bishops a call.

We couldn't squeeze all of our fastener codes into this catalogue – this is just a small fraction of our total range.

Whatever you need – Find it at Bishops.

MADE FOR EACH OTHER

The first nuts and bolts appeared in the middle 1400s.

The bolts were just screws with straight sides and a blunt end.

The nuts were handmade, and very crude. When a match was found between a nut and a bolt, they were kept together until they were finally assembled.



HEX NUTS – METRIC FINE

• Black finish



Size	Pitch	Bishops Code	Size	Pitch	Bishops Code
M8	1.00mm	44608990	M14	1.50mm	44614990
M10	1.25mm	44610990	M16	1.50mm	44616990
M12	1.25mm	44611990	M18	1.50mm	44618990
M12	1.50mm	44612990	M20	1.50mm	44620990

GRADE 2 HEX NUTS – METRIC

• Black finish



Size	Pitch	Bishops Code	Size	Pitch	Bishops Code
M4	0.70mm	44404990	M16	2.00mm	44416990
M5	0.80mm	44405990	M18	2.50mm	44418990
M6	1.00mm	44406990	M20	2.50mm	44420990
M8	1.25mm	44408990	M22	2.50mm	44422990
M10	1.50mm	44410990	M24	3.00mm	44424990
M12	1.75mm	44412990	M30	3.50mm	44430990
M14	2.00mm	44414990	M36	4.00mm	44436990

GRADE 2 HEX NUTS – IMPERIAL UNF

• Black finish



Size	TPI	Bishops Code	Size	TPI	Bishops Code
¼"	28	44230990	⅝"	18	44242990
⅜"	24	44232990	¾"	16	44246990
½"	24	44234990	⅞"	14	44250990
⅞"	20	44236990	1"	12	44254990
1½"	20	44238990	1½"	12	44258990
2"	18	44240990	–	–	–

GRADE 5 & 8 HEX NUTS – IMPERIAL UNC

• Black finish



Size	TPI	Grade	Bishops Code	Size	TPI	Grade	Bishops Code
¼"	20	5	44030990	¾"	10	8	44046990
⅜"	18	5	44032990	⅞"	9	8	44050990
½"	16	5	44034990	1"	8	8	44054990
⅞"	14	5	44036990	1½"	7	8	44058990
1"	13	8	44038990	1¾"	7	8	44062990
1¼"	12	8	44040990	2"	6	8	44070990
1½"	11	8	44042990	2½"	5	8	44084990

GRADE 316 STAINLESS STEEL HEX NUTS – METRIC COARSE



Size	Pitch	Bishops Code	Size	Pitch	Bishops Code
M4	0.70mm	42304990	M12	1.75mm	42312990
M5	0.80mm	42305990	M16	2.00mm	42316990
M6	1.00mm	42306990	M20	2.50mm	42320990
M8	1.25mm	42308990	M24	3.00mm	42324990
M10	1.50mm	42310990	–	–	–

THAT'S NUTS...

On a Caterpillar 797 dump truck it takes 54 M36 nuts to hold each of the 4 metre tall wheels

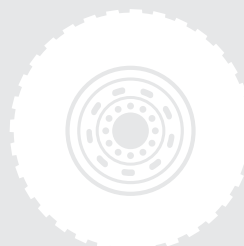

Each wheel weighs 5.3 tonnes!



LOCKNUTS & WASHERS GUIDE

ZINC PLATED P-TYPE NYLOC NUTS – METRIC

• DIN 985



Size	Pitch	Bishops Code	Size	Pitch	Bishops Code
3mm	0.50mm	45656003	16mm	2.00mm	45650016
4mm	0.70mm	45650004	18mm	2.50mm	45650018
5mm	0.80mm	45650005	20mm	2.50mm	45650020
6mm	1.00mm	45650006	22mm	2.50mm	45650022
8mm	1.25mm	45650008	24mm	3.00mm	45650024
10mm	1.50mm	45650010	30mm	3.50mm	45650030
12mm	1.75mm	45650012	36mm	4.00mm	45650036
14mm	2.00mm	45650014	-	-	-

ZINC PLATED P-TYPE NYLOC NUTS – IMPERIAL

- Regular hex standard height series
- IFI 100/107



IMPERIAL UNC			IMPERIAL UNF		
Size	TPI	Bishops Code	Size	TPI	Bishops Code
3/16"	24	45610018	3/16"	32	45630018
1/4"	20	45610025	1/4"	28	45630025
5/16"	18	45610031	5/16"	24	45630031
3/8"	16	45610037	3/8"	24	45630037
7/16"	14	45610043	7/16"	20	45630043
1/2"	13	45610050	1/2"	20	45630050
9/16"	12	45610056	9/16"	18	45630056
5/8"	11	45610062	5/8"	18	45630062
3/4"	10	45610075	3/4"	16	45630075
7/8"	9	45610087	7/8"	14	45630087
1"	8	45610100	1"	12	45630100
1 1/8"	7	45610112	1 1/4"	12	45630125
1 1/4"	7	45610125	2"	-	45630200
1 1/2"	6	45610150	-	-	-
1 3/4"	5	45610175	-	-	-
2"	4.5	45610200	-	-	-

STAINLESS STEEL NYLOC NUTS – METRIC & IMPERIAL

• DIN 985



Size	Pitch	Bishops Code	Size	Pitch	Bishops Code
METRIC					
4mm	0.70mm	45656004	8mm	1.25mm	45656008
5mm	0.80mm	45656005	10mm	1.50mm	45656010
6mm	1.00mm	45656006	12mm	1.75mm	45656012
IMPERIAL					
3/16"	24	45616018	3/8"	16	45616037
1/4"	20	45616025	1/2"	13	45616050
5/16"	18	45616031	-	-	-

A GUIDE TO WASHERS

Washers are used to distribute the pressure of a fastener evenly over the surface being fastened to. Typically they are round, although we also offer square washers and many different types of specialty washers to suit any application.

Flat Round Steel Washers are your bread and butter of washers. Usable with many different types of fasteners, they are available in a range of grades and finishes. Commercial washers are not manufactured to exact size specifications but rather to tolerances. Engineer's washers are produced to strict size regulations and will not deviate. Hardened washers are available for high tensile situations.

Nylon Washers are suitable for electrical and chemical industries because of their natural insulative properties and resistance to corrosive substances.

Brass Washers are known for their low-friction properties and are suitable for applications in plumbing, electrical work, gearing and more.

Fibre Washers will never rust, are non-abrasive, absorb vibration and noise, and compress under pressure to offer excellent sealing in plumbing applications and more.

Spring Washers are available with flat or square section. Used to provide tension under load.

Star Washers are designed to increase locking force by resisting torque from the nut and preventing it from unscrewing. Available with internal or external teeth for wide suitability.

Structural Washers are used to provide a smooth bearing surface under the head of the bolt or nut in structural connections.

Load & Tension Indicating Washers are designed to allow you to accurately tension a bolt with ease. Visual inspection is possible with squitter washers that will 'squirt' out orange silicone.

Square Washers serve the same function as flat round washers. They can be useful in applications where a round washer simply won't fit.

Cup Washers are lightweight, dished washers often used for decoration or support with countersunk screws. They create a finished look with the advantage of being snag free.

Disc Springs or Belleville washers are conical shells that can be stacked in the same or an alternating direction. They provide a high amount of spring force with minimal compression.

HDS Load Washers are developed specifically for high strength bolts. They are powerful safety washers in the form of a disc spring.

Serrated Lock Washers secure bolted joints with tension, rather than friction. They are used to secure bolts subject to severe vibration or dynamic loads.

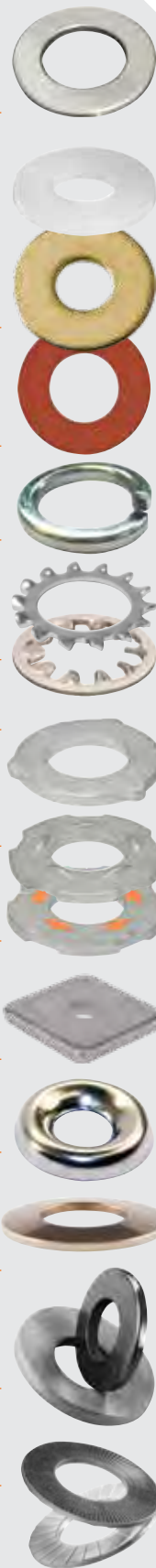

ZINC PLATED/BLACK FLAT ROUND WASHERS – METRIC & IMPERIAL

- Mild steel (nearest standard BS3410 and AS1237)
- Suitable for use with metric and imperial commercial grade bolts



Nominal Bolt Size	Bishops Code	Nominal Bolt Size	Bishops Code
3mm (1/8")	45810012	16mm (5/8")	45810062
4mm (1/8")	45810015	18mm (11/16")	45810068
5mm (3/16")	45810018	20mm (3/4")	45810075
6mm (1/4")	45810025	22mm (7/8")	45810087
8mm (5/16")	45810031	24mm (1")	45810100
10mm (3/8")	45810037	29mm (1 1/8")	45810112
11mm (7/16")	45810043	30mm (1 1/4")	45810125
12mm (1/2")	45810050	38mm (1 1/2")	45810150
14mm (9/16")	45810056	44mm (1 3/4")	45810175

GRADE 304 STAINLESS STEEL FLAT WASHERS – METRIC & IMPERIAL



Size	O.D.	Thickness	Bishops Code
3mm (1/8")	7mm	0.5mm	45830012
4mm (1/8")	9mm	0.8mm	45830016
5mm (3/16")	10mm	0.8mm	45830018
6mm (1/4")	12.5mm	1.2mm	45830025
8mm (5/16")	17mm	1.2mm	45830031
10mm (3/8")	21mm	1.2mm	45830037
12mm (1/2")	24mm	1.5mm	45830050
16mm (5/8")	30mm	1.5mm	45830062
19mm (3/4")	38mm	1.5mm	45830075
24mm (1")	44mm	3mm	45830100

ZINC PLATED/BLACK SPRING WASHERS – METRIC & IMPERIAL



Size	Bishops Code	Size	Bishops Code
4mm	45840015	16mm (5/8")	45840062
5mm (3/16")	45840018	18mm (11/16")	45840068
6mm (1/4")	45840025	20mm (3/4")	45840075
8mm (5/16")	45840031	22mm (7/8")	45840087
10mm (3/8")	45840037	24mm (1")	45840100
11mm (7/16")	45840043	29mm (1 1/8")	45840112
12mm (1/2")	45840050	30mm (1 1/4")	45840125
14mm (9/16")	45840056	38mm (1 1/2")	45840150

GRADE 316 STAINLESS STEEL SPRING WASHERS – METRIC & IMPERIAL



Size	O.D.	Thickness	Width	Bishops Code
4mm (3/32")	7.6mm (0.293")	0.9mm (0.040")	1.5mm (0.055")	45850015
5mm (3/16")	9.2mm (0.334")	1.2mm (0.047")	1.8mm (0.062")	45850018
6mm (1/4")	11.8mm (0.489")	1.6mm (0.062")	2.5mm (0.109")	45850025
8mm (5/16")	14.8mm (0.586")	2.0mm (0.078")	3.0mm (0.125")	45850031
10mm (3/8")	18.1mm (0.683")	2.2mm (0.094")	3.5mm (0.141")	45850037
13mm (1/2")	21.8mm (0.873")	3.0mm (0.125")	4.3mm (0.171")	45850050
14mm (9/16")	24.1mm (0.964")	3.0mm (0.125")	4.5mm (0.180")	45850055
16mm (5/8")	27.4mm (1.079")	3.5mm (0.156")	5.0mm (0.203")	45850062

NORD-LOCK WASHERS



Size	OD	Thickness	Bishops Code
8mm	13.5mm	2.5mm	45870200
12mm	19.5	2.5mm	45870220



FASTENER FACTS

The origin of the word washer is unknown; the first recorded use of the word was in 1346, however, the first time its definition was recorded was in 1611.





USES & APPLICATIONS – SOCKET HEAD SCREWS

Socket head screws are used in a wide range of industries and environments. They are known for their incredibly high tensile strength. This strength can translate to an increase in safety, reliability and savings for your business.

The **socket head screws** in this catalogue are primarily Class 12.9 or a close fit. This high tensile strength means fewer socket head screws are required to do the same work as more hex head bolts of a lower tensile strength. Less screws to buy means less money spent, less holes to drill means less time spent on the job.

Socket head screws are readily available in a wide range of diameters and lengths from as small as a M1.6 diameter with a 3mm length, to as large as an M42 diameter with a massive 340mm length. That's big!

Another advantage of **socket head screws** is their narrow design which allows them to fit into areas with low clearances and poor accessibility.

Socket head screws are available with a variety of head styles.

The most common ones are:

- **Socket head cap screws (SHCS)**
- **Socket head low cap screws**
- **Countersunk flat head socket screws**
- **Button head socket screws**
- **Cup point socket set screws (grub screws)**

We can also supply socket head screws with a wide range of security heads. There are permanent and removable styles to suit your needs. Contact us for more information.

If you can't find what you're looking for, just give us a call and we'll find it for you.



CLASS 12.9 SOCKET SCREWS – METRIC COARSE

- Head cap
- Black finish
- Specifications: ISO 4762, ANSI B18.3.1M and DIN 912



Dia.	M4	M5	M6	M8	M10	M12	M14	M16	M18	M20
Length	Bishops Code									
10mm	42804010	42805010	42806010	-	-	-	-	-	-	-
12mm	-	-	-	-	-	42812012	-	-	-	-
16mm	42804016	42805016	42806016	42808016	42810016	-	-	-	-	-
20mm	42804020	42805020	42806020	42808020	42810020	42812020	-	-	-	-
25mm	42804025	42805025	42806025	42808025	42810025	42812025	-	42816025	-	-
30mm	42804030	42805030	42806030	42808030	42810030	42812030	42814030	42816030	-	-
35mm	42804035	42805035	42806035	42808035	42810035	42812035	42814035	42816035	-	-
40mm	42804040	42805040	42806040	42808040	42810040	42812040	42814040	42816040	-	42820040
45mm	42804045	42805045	42806045	42808045	42810045	42812045	42814045	42816045	-	-
50mm	42804050	42805050	42806050	42808050	42810050	42812050	42814050	42816050	-	-
55mm	-	-	-	42808055	42810055	42812055	-	42816055	-	-
60mm	-	-	42806060	42808060	42810060	42812060	42814060	42816060	-	-
65mm	-	-	-	42808065	42810065	42812065	-	42816065	-	42820065
70mm	-	-	-	42808070	42810070	42812070	42814070	42816070	-	42820070
75mm	-	-	-	42808075	42810075	42812075	-	42816075	-	-
80mm	-	-	-	-	42810080	42812080	42814080	-	-	42820080
90mm	-	-	-	-	42810090	42812090	42814090	42816090	-	-
100mm	-	-	-	42808100	42810100	42812100	-	42816100	-	42820100
110mm	-	-	-	-	-	42812110	-	-	-	-
120mm	-	-	-	-	-	42812120	42814120	42816120	-	-
130mm	-	-	-	-	-	-	-	42816130	-	-
140mm	-	-	-	42808140	-	-	-	-	-	-
150mm	-	-	-	42808150	-	-	-	42816150	-	-
Pitch	0.70mm	0.80mm	1.00mm	1.25mm	1.50mm	1.75mm	2.00mm	2.00mm	2.50mm	2.50mm
Wrench	3mm	4mm	5mm	6mm	8mm	10mm	14mm	14mm	17mm	17mm



FASTENER FACTS

What do fastener ratings such as 2A or 3B really mean? This number-letter combo is used to indicate the **thread class** of the fastener. Thread classes include 1-4 (loose to tight), A (external), and B (internal). This represents the clearance fit, which translates into how much interference you can expect during assembly.

- Class 1** should be your choice when fast assembly and disassembly is your priority
- Class 2** is the most common and offers a balance between quality and economy
- Class 3** is ideal for applications requiring tight tolerances and a strong mating connection
- Class 4** is precision tight, typically used for lead screws and such

COUNTERSUNK SOCKET SCREWS – METRIC COARSE

- Flat head
- Black finish
- Specifications: DIN 7991, ISO 10642 and ANSI B 18.3.5M



Diameter	M6	M8	M10	M12
Length	Bishops Code			
10mm	43476010	–	–	–
16mm	43476016	43478016	–	–
20mm	43476020	43478020	43480020	43482020
25mm	43476025	43478025	43480025	43482025
30mm	43476030	43478030	43480030	43482030
35mm	43476035	43478035	43480035	43482035
40mm	43476040	43478040	43480040	43482040
45mm	43476045	–	43480045	–
50mm	43476050	43478050	43480050	43482050
55mm	–	–	–	–
60mm	–	–	–	43482060
70mm	–	–	–	43482070
Pitch	1.00mm	1.25mm	1.50mm	1.75mm
Wrench	4mm	5mm	6mm	8mm

GRUB SCREWS KNURLED CUP POINT – METRIC COARSE

- Black finish
- Specifications: ANSI B 18.3, BS 2470, ISO 4029 and DIN 916



Diameter	M5	M6	M8	M10	M12
Length	Bishops Code				
5mm	43275005	–	–	–	–
6mm	–	43276006	–	–	–
8mm	–	43276008	43278008	–	–
10mm	43275010	43276010	43278010	43280010	–
12mm	43275012	43276012	43278012	43280012	43282012
16mm	43275016	43276016	43278016	43280016	43282016
20mm	43275020	43276020	43278020	43280020	43282020
25mm	–	43276025	43278025	43280025	43282025
30mm	–	–	–	43280030	–
40mm	–	–	43278040	–	–
Pitch	0.80mm	1.00mm	1.25mm	1.50mm	1.75mm
Wrench	2.5mm	3mm	4mm	5mm	6mm



FASTENER FACTS

Who is the Phillips head screwdriver named after?

Henry F. Phillips invented the X-shaped socket head screw for car manufacturers. They required a screw that could handle greater torque and would hold tighter than a slotted screw. It also needed to centre quickly and easily, to suit assembly lines. The invention was initially rejected, but eventually accepted and in 1936 General Motors adopted the Phillips head screw in their manufacturing of the Cadillac.



MILD STEEL ALLTHREAD – METRIC

- Zinc plated
- Length: 1m

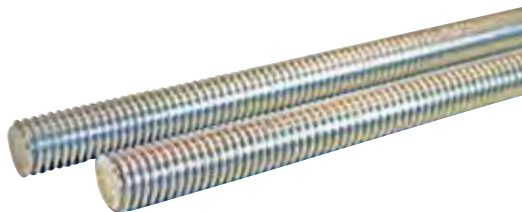

Diameter	Bishops Code	Diameter	Bishops Code
3mm	45450003	16mm	45450016
4mm	45450004	20mm	45450020
5mm	45450005	22mm	45450022
6mm	45450006	24mm	45450024
8mm	45450008	30mm	45450030
10mm	45450010	36mm	45450036
12mm	45450012	-	-

MILD STEEL ALLTHREAD – IMPERIAL UNC

- Length: 3ft

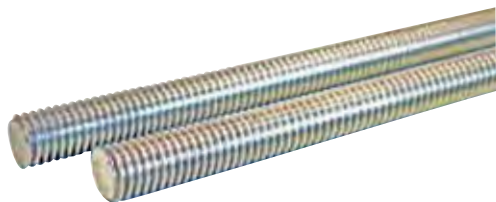

Diameter	Bishops Code	Diameter	Bishops Code
3/16"	45410018	5/8"	45410062
1/4"	45410025	3/4"	45410075
5/16"	45410031	7/8"	45410087
3/8"	45410037	1"	45410100
7/16"	45410043	1 1/8"	45410112
1/2"	45410050	1 1/4"	45410125

MILD STEEL ALLTHREAD – IMPERIAL UNF

- Length: 3ft

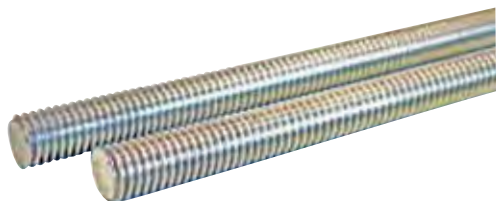

Diameter	Bishops Code	Diameter	Bishops Code
5/16"	45430025	3/4"	45430062
3/8"	45430031	7/8"	45430075
7/16"	45430037	1"	45430087
9/16"	45430050	1 1/8"	45430100

ALLTHREAD – METRIC

- Black finish
- Length: 1m

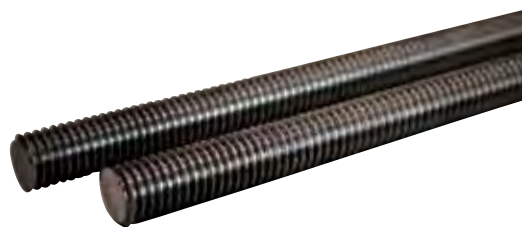

Diameter	Bishops Code	Diameter	Bishops Code
4mm	45452004	12mm	45452012
6mm	45452006	16mm	45452016
8mm	45452008	20mm	45452020
10mm	45452010	24mm	45452024

GALVANISED ALLTHREAD – METRIC

- Length: 1m

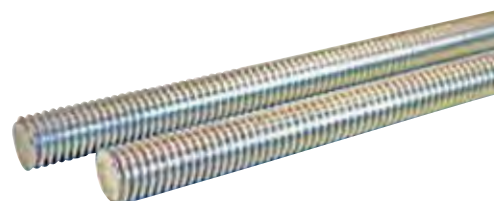

Diameter	Bishops Code	Diameter	Bishops Code
10mm	45440010	20mm	45440020
12mm	45440012	24mm	45440024
16mm	45440016	30mm	45440030

GRADE 316 STAINLESS STEEL ALLTHREAD – METRIC

- Length: 1m



Diameter	Bishops Code	Diameter	Bishops Code
5mm	45456005	12mm	45456012
6mm	45456006	16mm	45456016
8mm	45456008	20mm	45456020
10mm	45456010	24mm	45456024



FASTENER FACTS

The thread on a screw forms a helix, not a spiral. A helix is a 3D curve that twists around a cylinder at a constantly inclined angle.

FASTENER FACTS



The main difference between shear stress and tensile stress is that tensile stress refers to cases where a deforming force is applied at right angles to a surface, whereas shear stress refers to cases where a deforming force is applied parallel to a surface.

DYNABOLT™ PLUS SLEEVE ANCHORS

- Torque controlled expansion anchors with integrated pull-down section
- Designed for medium duty anchoring of timber and steel fixtures to concrete, brick or block



Size	Bishops Code	Size	Bishops Code
6 x 40mm	43606050	10 x 75mm	43610075
6 x 60mm	43606155	10 x 100mm	43610100
8 x 40mm	43608040	12 x 60mm	43612050
8 x 65mm	43608075	12 x 70mm	43612070
8 x 90mm	43608080	12 x 100mm	43612100
10 x 40mm	43610040	16 x 65mm	43616080
10 x 50mm	43610050	16 x 110mm	43616100
10 x 60mm	43610060	20 x 160mm	43620150

CHEMICAL ANCHORING ADHESIVES



43692150

Item Code	Description	Size	Bishops Code
MIT-SP	Polyester Adhesive Injection Cartridge	400ml	43692155
MIT-SE Plus	Vinyl Polyester Adhesive Injection Cartridge	400ml	43692160
MIT-700RE	Epoxy Adhesive Injection Cartridge	585ml	43692150
MIT-PP-H2	Applicator Gun To Suit 400ml Cartridge		43692172
MIT-PP-HT	Applicator Gun To Suit 585ml Cartridge		43692170
MUCMTMI11710064	Nozzle To Suit 585ml Cartridge		43692192



SCREW POINT STYLES

Different screw points are suitable for different materials and applications. Choose the right style for your situation with this handy guide.

Metal Point – This point style is suitable for drilling into steel sections. No punching, drilling or tapping required.

Several point styles are available.

Winged Metal Point – Designed to secure timber or composite materials to steel. The wings drill a wide hole through the timber or composite, breaking off in the process.





Metal Point, Extended Flute – Designed for drilling and fastening into thicker steel sections. Extra-long cutting flute drills, taps and seals in one operation.

Type 17 Point – Designed to drill through lighter sections of steel and into timber. The long, sharp point is fluted to capture chips while a coarse tapping screw thread cuts into timber.

Needle Point – A general purpose point found on screws with multiple applications and suitabilities. Perfectly mated threads increase strip and back-out pressures.

Chipboard/Treated Pine Point – Designed for fastening chipboard or timber. Available in both coarse and fine threads for different applications.

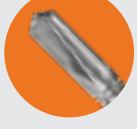
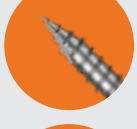
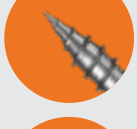
Type AB Point – A thread forming screw with locating point. Use with drilled, punched or nested holes. Suitable for light and heavy sheet metal and various other materials.

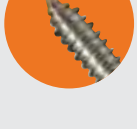
METRIC BOLTS, SET SCREWS & NUTS KITS



- Grade 8.8 High tensile steel
- Zinc plated



CA431



CA196

Item Code	Description	Kit Size	Bishops Code
CA431	Bolts, Set Screws & Nuts – Metric 17 Sizes: M4–M12 Dia.	431 Pieces	40410500
CA480	Set Screws & Nuts – Metric Fine 16 Sizes: M4–M12 Dia.	480 Pieces	*CA480
CA196	Set Screws & Nuts – Metric 18 Sizes: M4–M10 Dia.	226 Pieces	40410300

* – SPECIAL ORDER: PLEASE QUOTE ITEM CODE UPON ORDERING THIS PRODUCT



GRAB KITS – SCREWS, NUTS & WASHERS

FASTENERS

SCREW & NUT ASSORTMENT KITS



CA21

CA228

Item Code	Description	Kit Size	Bishops Code
ZINC PLATED			
CA21	Pan Head Phillips Recess Screws & Nuts – Metric 12 Sizes: M3–M6 Dia., 10–25mm Lengths	520 Pieces	40410010
NICKEL PLATED			
CA228	Round Head Slotted Screws & Nuts – Imperial Fine 14 sizes: $\frac{5}{16}$ "– $\frac{11}{32}$ "	300 Pieces	40410320

316 PIECE STAINLESS STEEL SET SCREWS & NUTS MASTER KIT – METRIC



- Stainless steel
 - Grade 304/A2
- Includes:**
- 17 sizes: M4 to M12 Diameter
 - Metal case



Item Code	Bishops Code
CA1880	40410910

SCREWS & NUTS KITS – METRIC



- Durable plastic handle
- Steel threads
- Zinc plated

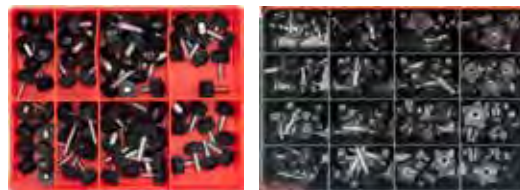

CA275

CA2275

Item Code	Description	Contains	Kit Size
CA275	Round Knurled Thumb Screws Kit	3 sizes: M4, M5, M6 Dia, 10, 16 & 25mm Lengths	90 Pieces
CA2275	Star Knob – Screw & Nut Master Kit	3 sizes: M6, M8, M10 Dia, 10, 16, 20, 25, 30 & 40mm Lengths	70 Pieces

SPECIAL ORDER: PLEASE QUOTE ITEM CODE UPON ORDERING THIS PRODUCT

420 PIECE NUT & BOLT ASSORTMENT GRAB KITS – METRIC & IMPERIAL

- Kits come with a variety of machine screws, washers and hex nuts
- Comes in hard plastic case for handy storage



Description	Bishops Code
Metric Kit	40420071
Imperial Kit	40420072

HOW TO CONTROL GALLING IN STAINLESS FASTENERS

Austenitic stainless steels (such as Grade 304 & 316) are widely used for corrosion resistant bolting. One of the major problems with their use is that disassembly is difficult because nuts and bolts seize. As pressure builds during tightening, protective surface oxides are broken, causing adhesion between surfaces.

This is known as galling and it is most prevalent with intermittently operated, slowly sliding surfaces.

To control galling, use different stainless alloy grades for bolt and nut. Combinations such as 400/316 or 304/316 have shown useful results.

Slow down the installation RPM. Use a torque wrench and the correct force for the material class and surface conditions.

Appropriate lubrication is required, even with permanent joints. Find anti-seize lubricant on page 435.



SECURITY SCREWS



Did you know Bishops can supply security screws?

If you need to make something tamper-proof, vandal-proof or theft-proof, we can source innovative products to help you stay one step ahead.

We can provide a full range of removable and permanent security screws. Mix and match head styles for the best protection!

Whatever you need – Find it at Bishops!

173 PIECE DOWTY SEALS WASHER MASTER KIT – METRIC & IMPERIAL



- Includes:**
- 22 sizes: 8–42mm and $\frac{1}{8}$ " to $1\frac{1}{4}$ " ID BSP



Item Code
CA2173

SPECIAL ORDER: PLEASE QUOTE ITEM CODE UPON ORDERING THIS PRODUCT

430 PIECE FIBRE WASHER ASSORTMENT KIT – IMPERIAL



- Red fibre
- Includes:**
- 14 sizes: 1/8" to 1" ID
- Thickness: 1/32"



Item Code	Bishops Code
CA400	40410430

COPPER WASHER KITS – METRIC



- Suitable for automotive and agricultural industries
- Great conductivity of heat and electricity



CA2260



CA225

Item Code	Description	Thickness	Kit Size	Bishops Code
CA1660	Metric – 10 Sizes: 5–24mm	1mm	260 Pieces	40410780
CA225	Imperial – 12 Sizes: 1/4"–1"	20g	260 Pieces	40410310
CA2260	Metric – 24 Sizes: 5–26mm	1, 1.5 & 2mm	565 Pieces	40410983
CA226	Metric – 14 Sizes: 6–26mm	1–2mm	305 Pieces	*CA226

* – SPECIAL ORDER: PLEASE QUOTE ITEM CODE UPON ORDERING THIS PRODUCT

WASHER GRAB KITS

- Comes in hard plastic case for handy storage



Description	Bishops Code
150 Piece Copper Washer Kit – 15 Sizes: 5–17.5mm ID	40420062
350 Piece Lock & Flat Washer Kit – #3–#10 Lock Washers & #3–#8 Flat Washers	40420067

132 PIECE DRAIN (SUMP) PLUG WASHER KIT – METRIC



- Fibre, aluminium and copper crush
- Includes:**
- 12 Sizes: 12–25mm ID



Item Code	Bishops Code
CA140	

SPECIAL ORDER: PLEASE QUOTE ITEM CODE UPON ORDERING THIS PRODUCT

143 PIECE BODY (PANEL) WASHER KIT – IMPERIAL



- Steel and stainless steel
- Zinc plated
- Includes:**
- 8 sizes: 3/16"–1/2" ID



Item Code	Bishops Code
CA1730	

SPECIAL ORDER: PLEASE QUOTE ITEM CODE UPON ORDERING THIS PRODUCT

HOW TO MEASURE A SCREW

The length of fasteners with non-countersunk heads are measured from under the head, while those with countersunk heads are measured overall.

Measure these types of screws from the underside of the head:

- Hex, Hex With Seal, Wafer, Pan, Button, Flat Head.

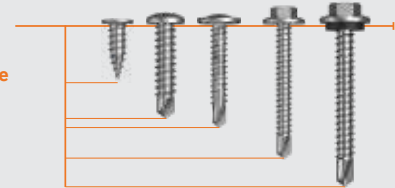

Measure these types of screws from the top of the head:

- Bugle, Plasterboard, Countersunk, Ribbed, Flower, Decking.

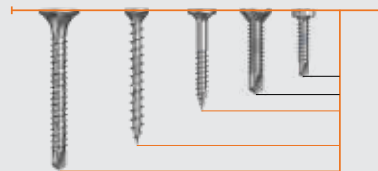

90 PIECE SOCKET HEAD CAP SCREW ASSORTMENT KIT – METRIC



- Socket head
- Grade 8.8 high tensile steel
- Includes:**
- 14 sizes: M5 to M10 diameter, lengths to 40mm



Item Code	Bishops Code
CA1417	40410700



SELF-DRILLING SCREWS

A self-drilling screw is designed to drill itself through a variety of materials and substrates. The difference between a self-tapping screw and a self-drilling screw is that a self-tapping screw cannot drill itself into material, only tap a thread in an existing hole, while self-drillers perform both actions.

Self-drilling screws are available with a variety of points, all suitable for different materials or applications. These points drill their own hole and cut a thread in the same motion.

Self-drilling screws are often supplied with a neoprene seal to prevent water entry. Other features also found on self-drillers include a Scratch Guard which prevents sheet metal from cutting into the coating.

Some of the most common uses for self-drilling screws are cladding and roofing, steel framing, HVAC work and construction of a general nature.

Coatings

Class 2

Suitable for general internal use where significant levels of condensation occurs. Most screws in this class will be electroplated zinc.

Class 3

Class 3 is the best choice for general purpose external applications, including moderate industrial and marine environments.

Class 4

Class 4 offers significant corrosion protection suitable for external use in moderate to severe marine environments.



SELF-TAPPING SCREW KITS – METRIC



- Phillips head

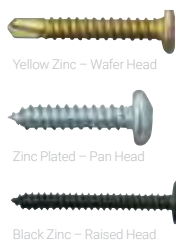

CA1710



CA530

Item Code	Contents	Screw Head	Finish	Kit Size	Bishops Code
CA1710	14 Sizes: 3.5–5.5mm, Lengths to 50mm	Pan	Zinc Plated	415 Pieces	40410795
CA1810	15 Sizes: 2.2–4.8mm Dia, Lengths to 38mm	Pan	Stainless Steel	415 Pieces	40410840
CA1200	14 Sizes: 3.5–4.8mm, Lengths to 38mm	Pan & Raised	Black Zinc	415 Pieces	*CA1200
CA1720	14 Sizes: 3.5–5.5mm, Lengths to 50mm	Mushroom	Black Zinc	415 Pieces	*CA1720
CA530	8 Sizes: 4.2–4.8mm, Lengths to 30mm	Wafer & Hex	Yellow Zinc	400 Pieces	*CA530

* – SPECIAL ORDER: PLEASE QUOTE ITEM CODE UPON ORDERING THIS PRODUCT

164 PIECE GRUB SCREW ASSORTMENT KIT – BSW & METRIC



- Grade 8.8 high tensile steel
- Includes:
- 14 sizes: 5–8mm and 3/16"–3/8" BSW



Item Code	Bishops Code
CA1416	40410690

450 PIECE GRUB SCREW KIT – METRIC

- Comes in hard plastic case for handy storage
- Includes:
- Long Screws 9 Sizes – 3 x 5mm to 10 x 12mm
- Long Fine Screws 3 Sizes – 6 x 6mm to 10 x 10mm



Item Code	Bishops Code
FD-6158G	40420074

RIVET TRADE SIZES

Rivet sizes are easily recognised by their Trade Size.

Once you know what size rivet you need, simply choose the appropriate material and style for your particular application.

Trade size of rivets is written in the following format:



Rivet Code	Rivet Diameter	Drill Hole Size
3	2.4mm (3/32")	2.5mm
4	3.2mm (1/8")	3.3mm
5	4.0mm (5/32")	4.1mm
6	4.8mm (3/16")	4.9mm
8	6.4mm (1/4")	6.5mm

Grip Code	Grip Range (Metric)	Grip Range (Imperial)
1	Up To 1.6mm	Up To 1/16"
2	1.6–3.2mm	1/16"–1/8"
3	3.2–4.8mm	1/8"–3/16"
4	4.8–6.4mm	3/16"–1/4"
5	6.4–7.9mm	1/4"–5/16"
6	7.9–9.5mm	5/16"–3/8"
8	9.5–12.7mm	3/8"–1/2"
10	12.7–15.9mm	1/2"–5/8"
12	15.9–19.0mm	5/8"–3/4"
14	19.0–22.2mm	3/4"–7/8"
16	22.2–25.4mm	7/8"–1"
20	25.4–31.8mm	1"–1 1/4"

500 PIECE RIVET GRAB KIT

- Comes in hard plastic case for handy storage
- Includes:
- 4 Sizes – 1/8" x 1/4" to 1/8" x 3/8"



Item Code	Bishops Code
FD-6046	40420063

505 PIECE ALUMINIUM BLIND RIVET KIT



- Short, medium and long rivets
- Includes:**
- 10 sizes: 2.4–4.8mm diameters



Item Code	Bishops Code
CA502	40410520

80 PIECE RIVET NUT INSERT KITS



- Includes:**
- 5 sizes: 4–10mm dia.



Item Code	Description
CA505	Steel
CA506	Aluminium

SPECIAL ORDER: PLEASE QUOTE ITEM CODE UPON ORDERING THIS PRODUCT

SPLIT (COTTER) PIN KITS



Item Code	Description	Kit Size	Bishops Code
ZINC PLATED			
CA2540	16 sizes: 1.6 x 22mm–6.3 x 50mm	1,540 pieces	40410985
CA1152	8 Sizes: 1.6–3.2mm, Including 7/64"	800 Pieces	40410650
CA800	10 Sizes: 1.6–4mm, Including 7/64" & 9/64"	795 Pieces	40410610
CA280	11 Sizes: 5–13mm, Including 3/8" and 1/2"	93 Pieces	40410350
STAINLESS STEEL			
CA1850	16 sizes: 1.6–5mm	225 Pieces	40410880

COTTER PIN & SPLIT PIN GRAB KITS

- Comes in hard plastic case for handy storage



Description	Bishops Code
144 Piece Large Cotter Pin Kit – 6 Sizes: 1/8" x 2" to 5/16" x 2 1/2"	40420055
280 Piece Cotter/Split Pin Kit – 6 Sizes: 1/16" x 1" to 5/32" x 2 1/2"	40420073

124 PIECE R CLIP KIT – IMPERIAL



- Zinc plated
- Includes:**
- 8 sizes: 1/8" to 1" shaft sizes

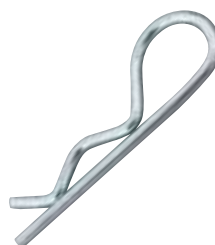

Item Code	Bishops Code
CA1745	40410820

HITCH PIN GRAB KITS

- Comes in hard plastic case for handy storage



Description	Bishops Code
150 Piece Hitch Pin Kit – 6 Sizes: 2.4 x 31mm to 4 x 75mm	40420056
56 Piece Clevis & Hitch Pin Kit – 5/16" to 1/2" Tiller Tine Pins & 1 3/16" to 1 3/4" Hair Pins	40420069

ROLL PIN KITS – METRIC & IMPERIAL



Item Code	Description	Kit Size	Bishops Code
CA1421	Imperial Small Sizes – 18 Sizes: 1/16"–1/4" Dia.	380 Pieces	40410720
CA1435	Imperial Large Sizes – 12 Sizes: 3/16"–3/8" Dia.	89 Pieces	40410740
CA1715	Metric Small Sizes – 18 Sizes: 2–6mm Dia.	360 Pieces	40410800
CA1725	Metric Large Sizes – 12 Sizes: 5–10mm Dia.	82 Pieces	40410810
CA2020	Metric Large Sizes – 24 sizes: 2–10mm Dia.	360 Pieces	40410950

315 PIECE ROLL PIN GRAB KIT – METRIC

- Comes in hard plastic case for handy storage
- Includes:**
- 30 Sizes – 1.5 to 10mm diameter



Item Code	Bishops Code
FD-6067	40420066



saturn 0.5 TONNE
DATE SECURE

MODEL NO.	HS-9	
SERIAL NO.		
LIFTING HEIGHT	5x15mm	COMPLIES WITH AS/NZS1418.2
LOAD CHAIN SIZE	80	
GRADE		MADE IN CHINA
DATE		

www.saturnproducts.com.au

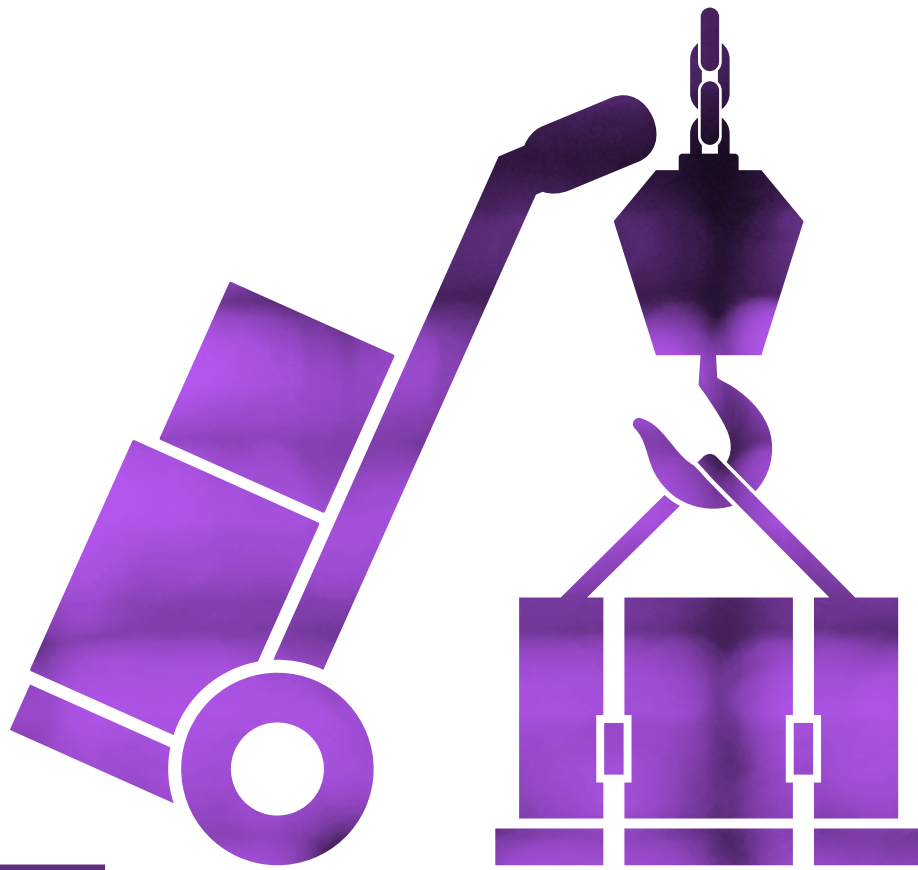

07

MATERIAL HANDLING & LIFTING

LIFTING

Polyester Slings	296
Wire Rope Slings	297–298
Wire Rope, Grips & Thimbles	298
Chain Slings & Lifting Chain	299
Lifting Hooks & Links	300–302
Lever & Chain Blocks	303
Chain Hoists, Wire Rope Creepers & Girder Trolleys	303
Plate Clamps	304
Sheave & Snatch Blocks	304

RIGGING

Lifting Shackles	304–305
Inspection Tags	305
Commercial Shackles & Hooks	305–306
Turnbuckles	306
Commercial Chain	307–308
Rope	308–309
Loadbinders	309
Snatch & Tie Down Straps	310–311
Vehicle & Recovery Winches	311

MATERIAL HANDLING

Container Ramps	312
Hand & Platform Trolleys	313
Gas Cylinder Trolleys & Drum Handling	313–314
Castor Wheels & Load Skates	315–316
Wheelbarrows	316
Pallet Trolleys, Trucks & Hooks	317
Forklift & Crane Accessories	317
Working Platforms & Storage Cages	318–319

STORAGE SOLUTIONS

Lifting & Storage Bags	319
Parts Bins, Buckets & IBC Containers	319
Dangerous Goods Storage	320–321



POLYESTER SLINGS

MATERIAL HANDLING & LIFTING

POLYESTER FLAT & ROUND SLING WORKING LOAD LIMITS (WLL)



Load Factor = L	L=1.0	L=0.8	L=2.0	L=1.9	L=1.7	L=1.4	L=1.0	L=1.7	L=1.4
Colour	Vertical WLL	Choke WLL	Basket WLL	30° WLL	60° WLL	90° WLL	120° WLL	60° WLL	60° Choke WLL
Violet	1.0t	0.8t	2.0t	1.9t	1.7t	1.4t	1.0t	1.7t	1.4t
Green	2.0t	1.6t	4.0t	3.8t	3.4t	2.8t	2.0t	3.4t	2.8t
Yellow	3.0t	2.4t	6.0t	5.7t	5.1t	4.2t	3.0t	5.1t	4.2t
Grey	4.0t	3.2t	8.0t	7.6t	6.8t	5.6t	4.0t	6.8t	5.6t
Red	5.0t	4.0t	10.0t	9.5t	8.5t	7.0t	5.0t	8.5t	7.0t
Brown	6.0t	4.8t	12.0t	11.4t	10.2t	8.4t	6.0t	10.2t	8.4t
Blue	8.0t	6.4t	16.0t	15.2t	13.6t	11.2t	8.0t	13.6t	11.72t
Orange	10.0t	8.0t	20.0t	19.0t	17.0t	14.0t	10.0t	17.0t	14.0t

Care & Use for Polyester Slings

- Slings have a lifespan of 10 years from date of manufacture
- Never overload the equipment
- Do not use if ID tag is removed
- Inspect before every use to ensure slings are not damaged
- Do not use sling if there is any sign of damage
- Do not tie knots in sling webbing
- Protect sling webbing from sharp edges of load
- Use protective gloves/sleeves
- Do not expose slings to temperatures above 90°C

FLAT LIFTING SLINGS

- 100% polyester yarn
- High strength and low stretch
- Lightweight and flexible
- Double ply
- UV resistant
- Colour-coded for easy identification
- Each sling comes with a test certificate
- Complies to ASNZ 1353-1: 1997
- Other sizes available on request



Colour	WLL	LENGTH						
		1m	2m	3m	4m	5m	6m	10m
Violet	1,000kg	Bishops Code 80006010	Bishops Code 80006020	Bishops Code 80006030	Bishops Code 80006040	-	Bishops Code 80006060	-
Green	2,000kg	Bishops Code 80006110	Bishops Code 80006120	Bishops Code 80006130	Bishops Code 80006140	-	Bishops Code 80006160	-
Yellow	3,000kg	Bishops Code 80006210	Bishops Code 80006220	Bishops Code 80006230	Bishops Code 80006240	-	Bishops Code 80006260	-
Grey	4,000kg	-	Bishops Code 80006320	Bishops Code 80006330	Bishops Code 80006340	Bishops Code 80006341	Bishops Code 80006360	-
Red	5,000kg	-	Bishops Code 80006361	Bishops Code 80006362	Bishops Code 80006363	Bishops Code 80006364	Bishops Code 80006365	-
Brown	6,000kg	-	-	-	-	-	Bishops Code 80006460	-
Orange	10,000kg	-	-	-	-	-	Bishops Code 80006670	Bishops Code 80006700

ENDLESS ROUND LIFTING SLINGS

- Single ply, low stretch polyester
- Lightweight, flexible and easy to handle
- UV resistant
- Moisture resistant fabric prevents frost damage
- Duplex construction from PU-starched thermally fixed web fabric
- Colour-coded for easy identification
- Each sling comes with a test certificate
- Complies to AS4497.1
- Other sizes available on request



Colour	WLL	LENGTH									
		1m	2m	3m	4m	5m	6m	8m	10m	12m	16m
Violet	1,000kg	Bishops Code 80008005	Bishops Code 80008010	-	Bishops Code 80008020	-	Bishops Code 80008030	Bishops Code 80008040	-	-	-
Green	2,000kg	Bishops Code 80008105	Bishops Code 80008110	Bishops Code 80008115	Bishops Code 80008120	-	Bishops Code 80008130	Bishops Code 80008140	Bishops Code 80008150	Bishops Code 80008160	-
Yellow	3,000kg	Bishops Code 80008200	Bishops Code 80008210	Bishops Code 80008215	Bishops Code 80008220	-	Bishops Code 80008230	Bishops Code 80008240	Bishops Code 80008250	-	-
Grey	4,000kg	-	Bishops Code 80008310	Bishops Code 80008315	Bishops Code 80008320	-	Bishops Code 80008330	Bishops Code 80008340	-	Bishops Code 80008360	-
Red	5,000kg	-	Bishops Code 80008361	Bishops Code 80008362	Bishops Code 80008363	Bishops Code 80008364	Bishops Code 80008365	-	-	-	-
Brown	6,000kg	-	Bishops Code 80008410	-	Bishops Code 80008420	-	Bishops Code 80008430	Bishops Code 80008440	-	-	-
Blue	8,000kg	-	-	-	Bishops Code 80008520	-	Bishops Code 80008530	Bishops Code 80008540	-	Bishops Code 80008560	-
Orange	10,000kg	-	Bishops Code 80008610	-	Bishops Code 80008620	-	Bishops Code 80008630	Bishops Code 80008640	Bishops Code 80008650	Bishops Code 80008660	Bishops Code 80008680
Orange	15,000kg	-	-	-	-	-	-	Bishops Code 80008693	-	Bishops Code 80008696	-
Orange	20,000kg	-	-	-	-	-	Bishops Code 80008718	Bishops Code 80008728	Bishops Code 80008732	-	-

USING YOUR WIRE ROPE SLING SAFELY



- Never exceed the WLL (working load limit). Always know the lifting capacity of your wire rope. Overloading will cause individual wires to fracture and stretch.
- Avoid kinking by ensuring that wire ropes are not used on sharp corners of your load. If this is unavoidable, make use of a wire rope protective sleeve.
- Never attempt to shorten the length of a wire rope sling by tying a knot in it. If you require to lift an uneven load source, use a specially designed sling.
- Ensure that when using a multi-leg sling, the load is spread evenly and is as balanced as possible. Careless placement of the load will cause damage to your sling.
- Do not expose wire ropes to any cutting or welding operations.
- Do not use excessive force to hammer wire rope into an unnatural position such as a choke hitch. If this is required, a synthetic sling will better serve the application.

WIRE ROPE SLINGS – WORKING LOAD LIMITS

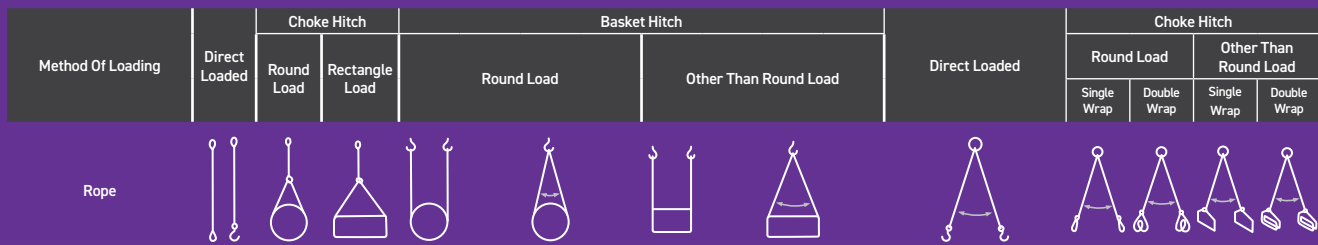

Method Of Loading	Direct Loaded	Choke Hitch		Basket Hitch				Direct Loaded	Choke Hitch										
		Round Load	Rectangle Load	Round Load		Other Than Round Load			Round Load	Other Than Round Load									
		Single Wrap	Double Wrap	Single Wrap	Double Wrap			Single Wrap	Double Wrap	Single Wrap	Double Wrap								
Included Angle				0°	60°	90°	120°	0°	60°	90°	120°	0-60°	90°	120°	0-45°	0-60°	0-45°	0-60°	
Nom. Dia. (mm)	Min. Breaking Force (kN)	Safe Working Loads in Tonnes – Under General Use With 1570 Grade Wire And Fibre Core With Ferrule Secured Eyes																	
8	28.2	0.55	0.41	0.27	1.09	0.94	0.77	0.55	0.55	0.48	0.39	0.27	0.94	0.77	0.55	0.71	0.71	0.48	0.48
9	35.6	0.69	0.52	0.34	1.38	1.19	0.97	0.69	0.69	0.6	0.49	0.34	1.19	0.97	0.69	0.9	0.9	0.6	0.6
10	44	0.85	0.64	0.43	1.7	1.47	1.2	0.85	0.85	0.74	0.61	0.43	1.47	1.2	0.85	1.11	1.11	0.74	0.74
11	53.2	1.03	0.77	0.52	2.1	1.78	1.45	1.03	1.03	0.9	0.73	0.52	1.78	1.45	1.03	1.34	1.34	0.9	0.9
12	63.3	1.23	0.92	0.61	2.5	2.1	1.73	1.23	1.23	1.07	0.87	0.61	2.1	1.73	1.23	1.59	1.59	1.07	1.07
13	74.3	1.44	1.08	0.72	2.9	2.5	2	1.44	1.44	1.25	1.02	0.72	2.5	2	1.44	1.87	1.87	1.25	1.25
14	86.2	1.67	1.25	0.83	3.3	2.9	2.4	1.67	1.67	1.67	1.19	0.83	2.9	2.4	1.67	2.2	2.2	1.45	1.45
16	113	2.2	1.64	1.09	4.4	3.8	3.1	2.2	2.2	1.9	1.55	1.09	3.8	3.1	2.2	2.8	2.8	1.9	1.9
18	143	2.8	2.1	1.38	5.5	4.8	3.9	2.8	2.8	2.4	1.97	1.38	4.8	3.9	2.8	3.6	3.6	2.4	2.4
20	176	3.4	2.6	1.7	6.8	5.9	4.8	3.4	3.4	3	2.4	1.7	5.9	4.8	3.4	4.4	4.4	3	3
22	213	4.1	3.1	2.1	8.3	7.1	5.8	4.1	4.1	3.6	2.9	2.1	7.1	5.8	4.1	5.4	5.4	3.6	3.6
24	253	4.9	3.7	2.5	9.8	8.5	6.9	4.9	4.9	4.3	3.5	2.5	8.5	6.9	4.9	6.4	6.4	4.3	4.3
26	297	5.8	4.3	2.9	11.5	10	8.1	5.8	5.8	5	4.1	2.9	10	8.1	5.8	7.5	7.5	5	5
28	345	6.7	5	3.3	13.4	11.6	9.4	6.7	6.7	5.8	4.7	3.3	11.6	9.4	6.7	8.7	8.7	5.8	5.8
32	450	8.7	6.5	4.4	17.4	15.1	12.3	8.7	8.7	7.6	6.2	4.4	15.1	12.3	8.7	11.3	11.3	7.6	7.6
		Safe Working Loads in Tonnes – Under General Use With 1770 Grade Wire And Wire Rope Core With Ferrule Secured Eyes																	
8	40.2	0.78	0.58	0.39	1.56	1.35	1.1	0.78	0.78	0.68	0.55	0.39	1.35	1.1	0.78	1.01	1.01	1.68	1.68
9	51.1	0.99	0.74	0.49	1.98	1.71	1.4	0.99	0.99	0.86	0.7	0.49	1.71	1.4	0.99	1.29	1.29	0.86	0.86
10	63.1	1.22	0.92	0.61	2.4	2.1	1.72	1.22	1.22	1.06	0.87	0.61	2.1	1.72	1.22	1.59	1.59	1.06	1.06
11	76.3	1.48	1.11	0.74	3	2.6	2.1	1.48	1.48	1.29	1.05	0.74	2.6	2.1	1.48	1.92	1.92	1.29	1.29
12	90.8	1.76	1.32	0.88	3.5	3	2.5	1.76	1.76	1.53	1.25	0.88	3	2.5	1.76	2.3	2.3	1.53	1.53
13	107	2.1	1.55	1.04	4.1	3.6	2.9	2.1	2.1	1.8	1.47	1.04	3.6	2.9	2.1	2.7	2.7	1.8	1.8
14	124	2.4	1.8	1.2	4.8	4.2	3.4	2.4	2.4	2.1	1.71	1.2	4.2	3.4	2.4	3.1	3.1	2.1	2.1
16	161	3.1	2.3	1.56	6.2	5.4	4.4	3.1	3.1	2.7	2.2	1.56	5.4	4.4	3.1	4.1	4.1	2.7	2.7
18	204	4	3	1.98	7.9	6.8	5.6	4	4	3.4	2.8	1.98	6.8	5.6	4	5.1	5.1	3.4	3.4
20	252	4.9	3.7	2.4	9.8	8.4	6.9	4.9	4.9	4.2	3.5	2.4	8.4	6.9	4.9	6.3	6.3	4.2	4.2
22	305	5.9	4.4	3	11.8	10.2	8.3	5.9	5.9	5.1	4.2	3	10.2	8.3	5.9	7.7	7.7	5.1	5.1
24	363	7	5.3	3.5	14.1	12.2	9.9	7	7	6.1	5	3.5	12.2	9.9	7	9.1	9.1	6.1	6.1
26	426	8.30	6.2	4.1	16.5	14.3	11.6	8.3	8.3	7.2	5.9	4.1	14.3	11.6	8.3	10.7	10.7	7.2	7.2
28	494	9.6	7.2	4.8	19.1	16.6	13.5	9.6	9.6	8.3	6.8	4.8	16.6	13.5	9.6	12.4	12.4	8.3	8.3
32	646	12.5	9.4	6.3	25	22	17.6	12.5	12.5	10.9	8.9	6.3	22	17.6	12.5	16.3	16.3	10.9	10.9
36	817	15.8	11.9	7.9	32	27	22	15.8	15.8	13.8	11.2	7.9	27	22	15.8	21	21	13.8	13.8
40	1,010	19.6	14.7	9.8	39	34	28	19.6	19.6	17	13.9	9.8	34	28	19.6	25	25	17	17
44	1,220	24	17.7	11.8	47	41	33	24	24	21	16.8	11.8	41	33	24	31	31	21	21
48	1,450	28	21	14	56	49	40	28	28	24	19.9	14	49	40	28	37	37	24	24
52	1,710	33	25	16.6	60	57	47	33	33	29	24	16.6	57	47	33	43	43	29	29
56	1,980	38	29	19.2	77	66	54	38	38	33	27	19.2	66	54	38	50	50	33	33
60	2,270	44	33	22	88	76	62	44	44	38	31	22	76	62	44	57	57	38	38



WIRE ROPE, GRIPS & THIMBLES

WIRE ROPE

- Length made to your specifications



6 x 19 Fibre Core



6 x 37 Fibre Core

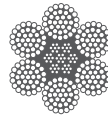

6 x 37 Wire Core



7 x 7 Wire Core

GALVANISED

SWL	Diameter	Bishops Code
CONSTRUCTION: 6 X 19S FIBRE CORE		
140kg	4mm	81058104
290kg	6mm	81058106
550kg	8mm	81058108
850kg	10mm	81058110
1,230kg	12mm	81058112
1,440kg	14mm	81058113

CONSTRUCTION: 6 X 37S FIBRE CORE		
2,200kg	16mm	81058116
2,950kg	18mm	81058119
3,400kg	20mm	81058120
4,100kg	24mm	81058124
6,700kg	28mm	81058128
8,700kg	32mm	81058132
10,300kg	36mm	81058136
12,800kg	40mm	81058140

CONSTRUCTION: 6 X 37S WIRE CORE		
3,100kg	16mm	81058316
4,000kg	18mm	81058318
4,900kg	20mm	81058320
7,000kg	24mm	81058324
9,600kg	28mm	81058328
12,500kg	32mm	81058332
15,800kg	36mm	81058336
19,600kg	40mm	81058340

BLACK

SWL	Diameter	Bishops Code
CONSTRUCTION: 6 X 19 FIBRE CORE		
290kg	6mm	81058206
850kg	10mm	81058210
1,230kg	12mm	81058212

CONSTRUCTION: 6 X 37 FIBRE CORE		
2,200kg	16mm	81058216
3,400kg	20mm	81058220
4,900kg	24mm	81058224

STAINLESS STEEL

Minimum Breaking Load	Diameter	Bishops Code
CONSTRUCTION: 7 X 7 WIRE CORE		
150kg	1.5mm	81058401
585kg	3mm	81058403
1,040kg	4mm	81058404
2,330kg	6mm	81058406
800kg	10mm	81058410

WIRE ROPE SLINGS

- All slings and assemblies are permanently marked with working load limit, based on 5:1 factor of safety
 - All slings and assemblies manufactured in accordance with AS1666
- Made To Your Requirements:**

- Hand spliced or machine swaged slings
- Can be fitted with your choice of terminations
- Can be manufactured and tested at short notice



Soft Eye
Machine Swaged



Steel Ferrule
Machine Swaged



Thimble Eye
Machine Swaged



Closed Swage
Socket



Soft Eye
Hand Spliced



Open Swage
Socket



Thimble Eye
Hand Spliced



Closed Spelter
Socket

PLEASE CONTACT BISHOPS WITH YOUR SPECIFICATIONS

WIRE ROPE GRIPS

- Galvanised



Size	Bishops Code	Size	Bishops Code
5mm	82080050	19mm	82080200
6mm	82080060	22mm	82080220
8mm	82080080	25mm	82080250
10mm	82080100	30mm	82080280
13mm	82080130	32mm	82080290
16mm	82080160	-	-

STAINLESS STEEL WIRE ROPE GRIPS

- Grade 316
- Not suitable for lifting applications



Size	Bishops Code	Size	Bishops Code
3mm	83080030	6mm	83080060
4mm	83080040	8mm	83080080
5mm	83080050	10mm	83080100

WIRE ROPE THIMBLES

- Galvanised



Size	Bishops Code	Size	Bishops Code
4mm	82085040	19mm	82085190
5mm	82085050	20mm	82085200
6mm	82085060	22mm	82085220
8mm	82085080	25mm	82085250
10mm	82085100	30mm	82085300
13mm	82085130	32mm	82085320
16mm	82085160	36mm	82085360

STAINLESS STEEL WIRE ROPE THIMBLES

- Grade 316



Size	Bishops Code	Size	Bishops Code
3mm	83085030	8mm	83085080
4mm	83085040	10mm	83085100
5mm	83085050	12mm	83085120
6mm	83085060	-	-

GRADE T (80) ALLOY LIFTING CHAIN MAXIMUM WORKING LOAD LIMITS

Chain Dia.	SINGLE LEG SLING			SLINGS OF 2,3 OR 4 LEGS						ENDLESS SLINGS			
	Straight Sling	Adjustable Sling	Reeved Sling	60°	90°	120°	60°	90°	120°	60°	90°	120°	Reeved Sling
6mm	1.1t	0.8t	0.8t	1.9t	1.6t	1.1t	1.5t	1.2t	0.8t	1.5t	1.2t	0.8t	1.7t
7mm	1.5t	1.1t	1.1t	2.6t	2.1t	1.5t	2t	1.6t	1.1t	2t	1.6t	1.1t	2.3t
8mm	2t	1.5t	1.5t	3.5t	2.8t	2t	2.6t	2.1t	1.5t	2.6t	2.1t	1.5t	3t
10mm	3.2t	2.4t	2.4t	5.5t	4.5t	3.2t	4.1t	3.4t	2.4t	4.1t	3.4t	2.4t	4.8t
13mm	5.3t	4t	4t	9.2t	7.5t	5.3t	6.9t	5.6t	4t	6.9t	5.6t	4t	8t
16mm	8t	6t	6t	13.8t	11.3t	8t	10.4t	8.5t	6t	10.4t	8.5t	6t	12t
20mm	12.5t	9.4t	9.4t	21.6t	17.6t	12.5t	16.3t	13.3t	9.4t	16.3t	13.3t	9.4t	18.8t
22mm	15t	11.3t	11.3t	26t	21.2t	15t	19.5t	15.9t	11.3t	19.5t	15.9t	11.3t	22.5t
26mm	21.2t	15.9t	15.9t	36.7t	29.9t	21.2t	27.6t	22.5t	15.9t	27.6t	22.5t	15.9t	31.8t
32mm	31.5t	23.6t	23.6t	54.5t	44.4t	31.5t	41t	33.4t	23.6t	41t	33.4t	23.6t	47.3t

CHAIN SLINGS

- Tested, tagged and certified AS 3775
- Grade 80
- Grade 100 and 120 and other sizes and lengths available on request



GRADE 80 LIFTING CHAIN

- Conforms to standards AS 2321
- Grade 80 alloy chain
- Black
- Heat treated
- Sold per metre



Size	Bishops Code	Size	Bishops Code
6mm	80010060	16mm	80010160
7mm	80010070	20mm	80010200
8mm	80010080	22mm	80010220
10mm	80010100	26mm	80010260
13mm	80010130	32mm	80010261

CARE & USE FOR LIFTING CHAIN

- Always visually inspect chain and fitting before use
- Ensure chain is free from twist and is protected from sharp corners on loads
- Never heat treat alloy chain or fittings
- Store in clean dry area
- Do not exceed SWL
- Do not exceed 120°C

Legs	Size	Bishops Code	Legs	Size	Bishops Code
1	6mm x 1m	80010270	2	13mm x 6m	80010460
1	6mm x 2m	80010275	2	13mm x 8m	80010465
1	8mm x 2m	80010280	4	13mm x 4m	80010470
2	8mm x 1m	80010282	4	13mm x 6m	80010480
3	8mm x 1m	80010285	2	16mm x 4m	80010500
4	8mm x 1.3mm	80010290	2	16mm x 6m	80010510
2	8mm x 2m	80010295	2	16mm x 8m	80010520
1	8mm x 3m	80010300	4	16mm x 4m	80010530
2	8mm x 3m	80010310	4	16mm x 6m	80010540
2	8mm x 4m	80010320	2	20mm x 3m	80010550
2	8mm x 8m	80010330	2	20mm x 4m	80010560
1	10mm x 2m	80010345	2	20mm x 6m	80010570
1	10mm x 3m	80010350	2	20mm x 8m	80010575
2	10mm x 2m	80010360	2	20mm x 12m	80010580
4	10mm x 2m	80010365	4	20mm x 4m	80010590
2	10mm x 4m	80010370	4	20mm x 6m	80010600
2	10mm x 6m	80010380	2	22mm x 4m	80010620
2	10mm x 8m	80010390	2	22mm x 6m	80010630
4	10mm x 4m	80010400	2	22mm x 8m	80010635
4	10mm x 6m	80010410	4	22mm x 4m	80010640
2	13mm x 2m	80010440	4	22mm x 6m	80010650
2	13mm x 4m	80010450	-	-	-

GET MORE AT BISHOPS



GENERAL PURPOSE CHAIN

Page 307



SLING MANUFACTURE & TESTING

Bishops has the facility and ability to manufacture chain and wire rope slings in-house.

With test equipment in Port Moresby, Bishops is able to test to Australian standards up to 200 tonnes, with certification for chain, wire rope and synthetic slings, as well as all lifting and rigging equipment.

Contact Bishops with your requirements

sales@bishopbros.com.pg

OBLONG MASTER LINKS

- Grade 80
- Tested to EN1677-1
- Design factor 4:1, proof tested and certified
- Forged master oblong links



Without Flat



With Flat

WLL 0-45°	1 Leg Chain Capacity	2 Leg Chain Capacity	Weight	Bishops Code
WITHOUT FLAT				
1,500kg	6mm	6mm	450g	80020060
2,700kg	8mm	7-8mm	550g	80020080
4,000kg	10mm	7-8mm	700g	80020100
7,500kg	13mm	10mm	1.5kg	80020130
10,000kg	16mm	13mm	2.8kg	80020160
17,000kg	22mm	16mm	5.5kg	80020200
28,000kg	26mm	19-20mm	8kg	80020260
WITH FLAT				
17,000kg	20mm	16mm	5.3kg	80020220

RECESSED MULTI-LEG MASTER OBLONG LINKS

- Designed for use with 2, 3 or 4 legs of chain or wire rope
- Proof tested and certified
- Complies to AS3776
- Grade 80



Chain Dia.	WLL	Unit Weight	Bishops Code
7-8mm	3,500kg	1.5kg	80024080
10mm	5,500kg	3.6kg	80024100
13mm	9,200kg	5.5kg	80024130
16mm	13,800kg	12kg	80024160
20mm	21,600kg	23.5kg	80024200
22mm	26,000kg	32.3kg	80024201
26mm	36,700kg	61kg	80024202
32mm	54,500kg	101.3kg	80024203

CONNECTING LINKS

- General connecting link used in the assembly of chain slings
- Design factor 4:1, proof tested and certified
- Tested to DIN EN1677-1
- Complies to AS3776
- Grade 80



Chain Dia.	WLL	Unit Weight	Bishops Code
6mm	1,100kg	0.08kg	80026060
7-8mm	2,000kg	0.2kg	80026070
10mm	3,200kg	0.3kg	80026100
13mm	5,300kg	0.7kg	80026130
16mm	8,000kg	1.1kg	80026160
20mm	12,500kg	1.9kg	80026200
22mm	15,000kg	3kg	80026220
26mm	21,200kg	4.7kg	80026260
32mm	31,500kg	10.0kg	80026270

DRUM LIFTING HOOK

- Design factor 4:1 proof tested and certified
- 1,000kg capacity
- For 16mm chain
- Eye connector
- Eye inside diameter: 38mm
- Hook width: 50mm
- 0.9kg weight



Item Code	Bishops Code
8-071-07	80084100

GET MORE AT BISHOPS



DRUM SPILL PALLETS

Page 44

CLEVIS SHORTENING GRAB HOOKS

- Clevis (pin) shortening grab hooks are used when the shortening of the chain is required on chain sling assemblies, without reduction in WLL
- Designed with supporting lugs both sides to prevent chain link deformation
- Design factor 4:1, proof tested and certified
- Tested to DIN EN1677-1
- Complies to AS3776
- Grade 80



Chain Dia.	WLL	Unit Weight	Bishops Code
6mm	1,100kg	0.2kg	80032065
7-8mm	2,000kg	0.3kg	80032070
10mm	3,200kg	0.8kg	80032100
13mm	5,300kg	1.6kg	80032130
16mm	8,000kg	2.8kg	80032160
20mm	12,500kg	5.0kg	80032200
22mm	15,000kg	7.2kg	80032220

EYE CONTAINER HOOKS

- Suitable for straight, left hand or right hand applications
- Design factor 4:1 proof tested and certified
- Tested to EN1677
- Grade 80
- 12,500kg WLL
- Weight: 3.9kg



Description	Bishops Code
45° Right	80061110
45° Left	80061120

CLEVIS SHORTENING CLUTCHES

- Design factor 4:1 proof tested and certified
- Tested to DIN EN1677-1
- Grade 80



Item Code	Chain Dia.	WLL	Unit Weight	Bishops Code
8-072-07	7-8mm	2,000kg	0.6kg	80030070
8-072-10	10mm	3,150kg	1.1kg	80030100
8-072-13	13mm	5,300kg	2.4kg	80030130
8-072-16	16mm	8,000kg	4.6kg	80030160

EYE SHORTENING GRAB HOOKS

- Eye shortening grab hooks are used when the shortening of the chain is required on chain sling assemblies, without reduction in WLL
- Designed with supporting lugs both sides to prevent chain link deformation
- Design factor 4:1, proof tested and certified
- Tested to DIN EN1677-1
- Complies to AS3776
- Grade 80



Item Code	Chain Dia.	WLL	Unit Weight	Bishops Code
8-041-06	6mm	1,100kg	0.2kg	80052060
8-041-07	8mm	2,000kg	0.3kg	80052070
8-041-10	10mm	3,200kg	0.6kg	80052100
8-041-13	13mm	5,300kg	1.4kg	80052130
8-041-16	16mm	8,000kg	2.2kg	80052160
8-041-20	20mm	12,500kg	3.8kg	80052200
8-041-22	22mm	15,000kg	4.6kg	80052220

EYE SELF-LOCKING HOOKS

- Design factor 4:1, proof tested and certified
- Tested to DIN EN1677-1
- Grade 80



Chain Dia.	WLL	Unit Weight	Bishops Code
6mm	1,120kg	0.5kg	80058060
7-8mm	2,000kg	0.8kg	80058070
10mm	3,150kg	1.4kg	80058100
13mm	5,300kg	2.9kg	80058130
16mm	8,000kg	5.7kg	80058160
20mm	12,500kg	8.5kg	80058200
22mm	15,000kg	12.5kg	80058220
26mm	21,200kg	14.5kg	80058260



LIFTING HOOKS

CLEVIS TYPE SELF-LOCKING SAFETY HOOKS

- Unique design and ease of operation that when taking up the load it will lock into place without disturbing the load
- Design factor 4:1, proof tested and certified
- Tested to DIN EN1677-1
- Complies to AS3776
- Grade 80



Chain Dia.	WLL	Unit Weight	Bishops Code
7-8mm	2,000kg	0.8kg	80038070
10mm	3,200kg	1.4kg	80038100
13mm	5,300kg	2.9kg	80038130
16mm	8,000kg	5.6kg	80038160
20mm	12,500kg	8.8kg	80038200
22mm	15,000kg	12.8kg	80038220

EYE SWIVEL SELF-LOCKING SAFETY HOOKS

- Ball bearing allows the hook to fully swivel
- Design factor 4:1 proof tested and certified
- Tested to DIN EN1677-1



Chain Dia.	WLL	Unit Weight	Bishops Code
7-8mm	2,000kg	1.2kg	80060070
10mm	3,200kg	2.0kg	80060100
13mm	5,300kg	4.2kg	80060130
16mm	8,000kg	7.3kg	80060160

EYE SWIVEL HOOKS WITH SAFETY LATCH

- Ball bearing allows the hook to fully swivel under the load
- Design factor 4:1, proof tested and certified
- Tested to DIN EN1677-1
- Grade 80



Chain Dia.	WLL	Unit Weight	Bishops Code
7-8mm	2,000kg	0.9kg	80060165
10mm	3,150kg	1.6kg	80060170
13mm	6,300kg	3.4kg	80060175
16mm	8,000kg	5.3kg	80060180

SLING HOOKS WITH SAFETY LATCH

- Comes with cast iron safety latch for general purpose lifting
- Design factor 4:1, proof tested and certified
- Tested to DIN EN1677-1
- Complies to AS3776
- Grade 80



Chain Dia.	WLL	Unit Weight	Bishops Code
6mm	1,100kg	0.3kg	80056060
7-8mm	2,000kg	0.5kg	80056070
10mm	3,200kg	0.9kg	80056100
13mm	5,300kg	1.9kg	80056130
16mm	8,000kg	3.2kg	80056160
20mm	12,500kg	5.7kg	80056200
26mm	21,200kg	13.6kg	80056260

CLEVIS SLING HOOKS WITH SAFETY LATCH

- Design factor 4:1, proof tested and certified
- Tested to DIN EN1677-1
- Grade 80



Chain Dia.	WLL	Unit Weight	Bishops Code
6mm	1,120kg	0.3kg	80036060
7-8mm	2,000kg	0.6kg	80036070
10mm	3,150kg	1.2kg	80036100
13mm	5,300kg	2.3kg	80036130
16mm	8,000kg	3.8kg	80036160
20mm	12,500kg	6.7kg	80036200

CONCRETE LIFTING EYE

- Comes with a high strength bail that rotates 180°
- Entire lifting eye can rotate through a 360° arc
- Wide degree of movement allows for the tilting, turning and rotating of precast concrete under load
- T-shaped slot makes it easy to attach and release the head of the anchor
- 10,000kg WLL



Bishops Code
80085184

GET MORE AT BISHOPS



RIGGERS GLOVES

Page 8

LEVER BLOCKS

- Heavy duty
- Load chain is a grade 80 alloy
- Can be used in any direction but must be a straight line
- Each lever block is supplied with a test certificate
- Complies with AS/NZS AS1418.2



Capacity	Lift Height	Bishops Code	Capacity	Lift Height	Bishops Code
250kg	1m	80520025	1,500kg	1.5m	80520150
500kg	1.5m	80520050	3,000kg	1.5m	80520300
750kg	1.5m	80520075	6,000kg	1.5m	80520600
1,000kg	1.5m	80520148	9,000kg	1.5m	80520722

CHAIN BLOCKS

- Heavy duty
- Suitable for vertical lifts only
- Load chain is a grade 80 alloy
- Capacities up to 30,000kg available
- Each chain block is supplied with a test certificate
- Complies with AS/NZS 1418.2



Capacity	Lift Height	Bishops Code	Capacity	Lift Height	Bishops Code
250kg	3m	80510008	10,000kg	5m	80510070
500kg	3m	80510010	250kg	6m	80510009
1,000kg	3m	80510020	1,000kg	6m	80510230
1,500kg	3m	80510030	2,000kg	6m	80510240
2,000kg	3m	80510040	3,000kg	6m	80510250
3,000kg	3m	80510050	5,000kg	6m	80510260
5,000kg	3m	80510060	10,000kg	6m	80510270
20,000kg	3m	80510076	-	-	-

ELECTRIC CHAIN HOISTS

- Pendant control
- Light aluminium alloy shell
- Inverse phase sequence protecting device
- Limit switch
- Side magnetic braking device
- Light, durable chain bag with uLa-treated steel alloy chain included
- Rotation speed: 1,440rpm
- 240V/415V
- Frequency: 50Hz
- CE and GS approved



80560210

Voltage	Capacity	Lifting Height	Lifting Speed	Motor Power	Bishops Code
240V	1,000kg	3-9m	6.6m/min	1.5kW	80560210
415V	5,000kg	3-9m	2.7-0.9m/min	3.0kW	80560225

TUFF PULL WIRE ROPE CREEPERS

- Complies to standards AS 1418.2
- Versatile, portable and compact
- Comes with 20m long wire rope and an operating lever
- Lightweight and easy to use
- High strength aluminium alloy housing
- Suitable for pulling, lifting, lowering and spanning, as well as 4WD recovery and securing loads over large distances



Lifting Capacity	Pulling Capacity	Rope Diameter	Weight with Rope	Bishops Code
800kg	1,250kg	8.3mm	7.5kg	81080080
1,600kg	2,500kg	11mm	12kg	81080160
3,200kg	5,000kg	16mm	25.3kg	81080320

PUSH TYPE GIRDER TROLLEYS

- Designed to fit beams, pipes and columns
- Adjustable to suit different widths
- Complies to AS 1418.2
- 30,000kg type available on request



80550100

WLL	Beam Width	Bishops Code	WLL	Beam Width	Bishops Code
500kg	63-152mm	80550050	5,000kg	114-203mm	80550500
1,000kg	64-203mm	80550100	10,000kg	127-210mm	80551000
2,000kg	102-203mm	80550200	20,000kg	136-305mm	80551050
3,000kg	100-305mm	80550250	-	-	-

WIRE ROPE CABLE PULLERS

- Steel constructed with drop forged hooks
- Complete with safety latches
- One hook has a built-in sheave block for ease of recovery
- 2 or 4t pulling capacity
- Suitable for recovery



Item Code	WLL	Bishops Code
TR8020	2t	81085200
TR8041	4t	81085240



PLATE CLAMPS, BLOCKS & SHACKLES

HORIZONTAL PLATE CLAMPS

- Designed to lift and transfer material in a horizontal position only
- Steel construction
- Must be used in pairs
- Sold in pairs only
- WLL ratings are per pair



WLL	Opening Size	Bishops Code	WLL	Opening Size	Bishops Code
1,000kg	0-30mm	80080010	2,000kg	0-100mm	80080020
1,500kg	0-50mm	80080015	3,000kg	0-100mm	80080030

VERTICAL PLATE CLAMPS

- Designed to lift and transport material in a vertical position only
- Easy to use
- Fitted with a safety locking mechanism
- Sold individually



WLL	Opening Size	Bishops Code	WLL	Opening Size	Bishops Code
1,000kg	0-20mm	80082010	3,000kg	0-30mm	80082030
2,000kg	0-40mm	80082020	5,000kg	0-50mm	80082031

SNATCH BLOCKS

- Heavy duty snatch blocks
- Suitable for wire rope
- Comes with shackle or hook attachment



Description	WLL	Diameter	Suits Wire Rope	Bishops Code
With Shackle	1.0t	105mm	8-11mm	80530002
With Shackle	2.0t	140mm	11-14mm	80530004
With Shackle	3.2t	170mm	12.5-15.5mm	80530006
With Shackle	5.0t	200mm	15.5-18.5mm	80530008
With Shackle	8.0t	275mm	20-32mm	80530010
With Shackle	2.0t	75mm	8-10mm	80531010
With Hook	2.0t	75mm	8-10mm	80531015
With Shackle	4.0t	115mm	10-13mm	80531020

DOUBLE & TRIPLE SNATCH BLOCKS



80540840

80540902

Description	WLL	Diameter	Bishops Code
Double Snatch Block	0.25t	75mm	80540840
Double Snatch Block	1.0t	85mm	80540850
Double Snatch Block	2.0t	180mm	80540852
Triple Snatch Block	0.25t	75mm	80540900
Triple Snatch Block	0.75t	100mm	80540901
Triple Snatch Block	1.0t	125mm	80540902

GET MORE AT BISHOPS

SAFETY TAGS & SIGNS
From Page 52

SHEAVE BLOCKS

- Single wheel



WLL	Diameter	Bishops Code
0.25t	75mm	80530000
0.5t	100mm	80530001

SCREW PIN DEE LIFTING SHACKLES

- Used with chains, wire rope and synthetic slings in a variety of lifting applications
- Individually stamped with WLL, month/year of manufacture and the grade of the shackle
- Complies to standard AS 2741



Size	WLL	Bishops Code	Size	WLL	Bishops Code
6 x 8mm Pin	500kg	80012006	25 x 28mm Pin	8,500kg	80012025
8 x 10mm Pin	750kg	80012008	28 x 32mm Pin	9,500kg	80012028
10 x 11mm Pin	1,000kg	80012010	32 x 35mm Pin	12,000kg	80012032
11 x 13mm Pin	1,500kg	80012011	35 x 38mm Pin	13,500kg	80012035
13 x 16mm Pin	2,000kg	80012013	38 x 42mm Pin	17,000kg	80012040
16 x 19mm Pin	3,200kg	80012016	45 x 50mm Pin	25,000kg	80012045
19 x 22mm Pin	4,750kg	80012019	51 x 57mm Pin	35,000kg	80012051
22 x 25mm Pin	6,500kg	80012022	-	-	-

SAFETY PIN DEE LIFTING SHACKLES

- Used with chains, wire rope and synthetic slings in a variety of lifting applications
- Individually stamped with WLL, month/year of manufacture and the grade of the shackle
- Complies to standard AS 2741



Size	WLL	Bishops Code	Size	WLL	Bishops Code
13 x 16mm Pin	2,000kg	80012113	25 x 28mm Pin	8,500kg	80012125
16 x 19mm Pin	3,200kg	80012116	29 x 32mm Pin	9,500kg	80012129
19 x 22mm Pin	4,750kg	80012119	32 x 35mm Pin	12,000kg	80012132
22 x 25mm Pin	6,500kg	80012122	-	-	-

SCREW PIN BOW LIFTING SHACKLES

- Used with chains, wire rope and synthetic slings in a variety of lifting applications
- Individually stamped with WLL, month/year of manufacture and the grade of the shackle
- Complies to standard AS 2741



Size	WLL	Bishops Code	Size	WLL	Bishops Code
5 x 6mm Pin	330kg	80016004	25 x 28mm Pin	8,500kg	80016025
6 x 8mm Pin	500kg	80016006	28 x 32mm Pin	9,500kg	80016028
8 x 10mm Pin	750kg	80016008	32 x 35mm Pin	12,000kg	80016032
10 x 11mm Pin	1,000kg	80016010	35 x 38mm Pin	13,500kg	80016035
11 x 13mm Pin	1,500kg	80016011	38 x 42mm Pin	17,000kg	80016038
13 x 16mm Pin	2,000kg	80016013	45 x 50mm Pin	25,000kg	80016045
16 x 19mm Pin	3,250kg	80016016	51 x 57mm Pin	35,000kg	80016051
19 x 22mm Pin	4,750kg	80016019	63 x 70mm Pin	55,000kg	80016066
22 x 25mm Pin	6,500kg	80016022	-	-	-

SAFETY PIN BOW LIFTING SHACKLES

- Used with chains, wire rope and synthetic slings in a variety of lifting applications
- Individually stamped with WLL, month/year of manufacture and the grade of the shackle
- Complies to standard AS 2741



Size	WLL	Bishops Code	Size	WLL	Bishops Code
13 x 16mm Pin	2,000kg	80016113	29 x 32mm Pin	9,500kg	80016129
16 x 19mm Pin	3,200kg	80016116	32 x 35mm Pin	12,000kg	80016132
19 x 22mm Pin	4,700kg	80016119	38 x 44mm Pin	17,000kg	80016138
22 x 25mm Pin	6,500kg	80016122	44 x 50mm Pin	25,000kg	80016145
25 x 29mm Pin	8,500kg	80016125	51 x 57mm Pin	35,000kg	80016151

LIFTING INSPECTION TAGS

- Inspection tag and cable tie in one
- Choice of blank tags or labelled with Next Inspection Due
- Length: 175m
- 100 per pack



Item Code	Description	Colour	Bishops Code
123171	Blank	Yellow	80008549
276347	Next Inspection Due Jan-Mar	Red	80008550
276348	Next Inspection Due Apr-Jun	Green	80008552
276346	Next Inspection Due Jul-Sep	Blue	80008554
276349	Next Inspection Due Oct-Dec	Yellow	80008555

COMMERCIAL GRADE D-SHACKLES WITH SCREW PIN



- Used in domestic, mining and any other industrial applications
- Comes with screw pin
- Made from hot dipped galvanised mild steel
- **Not suitable for lifting applications**
- B: inside diameter
- D: pin diameter
- D1: body diameter
- C: bow width

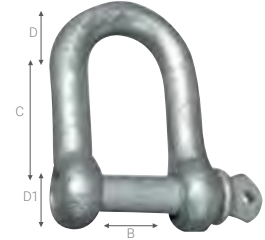

Size	B	D	D1	C	Weight	Bishops Code
6mm	12mm	6mm	6mm	24mm	250g	82035060
8mm	16mm	8mm	8mm	32mm	540g	82035080
10mm	20mm	10mm	10mm	40mm	109g	82035100
13mm	25mm	13mm	13mm	48mm	205g	82035130
16mm	32mm	16mm	16mm	64mm	480g	82035160
20mm	38mm	20mm	20mm	76mm	815g	82035200
22mm	44mm	22mm	22mm	85mm	1.285kg	82035220
25mm	25mm	25mm	25mm	95mm	1.866kg	82035250

COMMERCIAL GRADE BOW SHACKLES WITH SCREW PIN



- Used in domestic, mining and any other industrial applications
- Comes with screw pin
- Made from hot dipped galvanised mild steel
- **Not suitable for lifting applications**
- B: inside diameter
- D: pin diameter
- D1: body diameter
- C: bow width



Size	B	D	D1	C	Weight	Bishops Code
6mm	15mm	6mm	6mm	22mm	20g	82040060
8mm	16mm	8mm	8mm	24mm	70g	82040080
10mm	20mm	10mm	10mm	30mm	140g	82040100
13mm	25mm	13mm	13mm	39mm	250g	82040130
16mm	32mm	16mm	16mm	48mm	550g	82040160
20mm	44mm	22mm	22mm	85mm	1.35kg	82040200
22mm	48mm	22mm	22mm	95mm	1.56kg	82040220
25mm	50mm	25mm	25mm	100mm	2.05kg	82040250

STAINLESS STEEL STANDARD DEE SHACKLES



- Grade 316
- **Not suitable for lifting applications**



Size	Bishops Code	Size	Bishops Code
4 x 4mm	83035040	8 x 8mm	83035080
5 x 5mm	83035050	10 x 10mm	83035100
6 x 6mm	83035060	12 x 12mm	83035120



COMMERCIAL GRADE HOOKS, SHACKLES & TURNBUCKLES

STAINLESS STEEL STANDARD BOW SHACKLES

- Grade 316
- Not suitable for lifting applications



Size	Bishops Code	Size	Bishops Code
4 x 4mm	83040040	10 x 10mm	83040100
5 x 5mm	83040050	12 x 12mm	83040120
6 x 6mm	83040060	16 x 16mm	83040160
8 x 8mm	83040080	-	-

STAINLESS STEEL EYE & EYE SWIVELS

- Grade 316
- Not suitable for lifting applications



Size	Bishops Code	Size	Bishops Code
5mm	83055050	9mm	83055090
6mm	83055060	10mm	83055100
8mm	83055080	13mm	83055130

STAINLESS STEEL CARBINE HOOKS

- Grade 316
- Not suitable for lifting applications

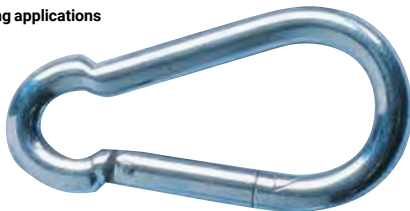

Size	Bishops Code	Size	Bishops Code
5mm	83010050	8mm	83010080
6mm	83010060	9mm	83010090
7mm	83010070	10mm	83010100

STAINLESS STEEL CARBINE HOOKS WITH GROMET

- Grade 316
- Not suitable for lifting applications



Size	Bishops Code	Size	Bishops Code
5mm	83014050	10mm	83018100
6mm	83014060	11mm	83018110
7mm	83014070	12mm	83018120
8mm	83018080	-	-

HOOK & EYE TURNBUCKLES

- Forged hot dipped galvanised
- Commercial grade
- Not suitable for lifting applications



Size	Bishops Code	Size	Bishops Code
5mm	82065050	16mm	82065160
6mm	82065060	20mm	82065200
8mm	82065080	22mm	82065220
10mm	82065100	24mm	82065240
12mm	82065130	27mm	82065270

EYE & EYE TURNBUCKLES

- Forged hot dipped galvanised
- Commercial grade
- Not suitable for lifting applications



Size	Bishops Code	Size	Bishops Code
6mm	82060060	16mm	82060160
8mm	82060080	20mm	82060200
10mm	82060100	22mm	82060220
12mm	82060130	24mm	82060240

STAINLESS STEEL HOOK & EYE TURNBUCKLES

- Grade 316
- Not suitable for lifting applications



Size	Bishops Code
5mm	83065050
6mm	83065060
8mm	83065080
10mm	83065100

STAINLESS STEEL EYE & EYE TURNBUCKLES

- Grade 316
- Not suitable for lifting applications



Size	Bishops Code
6mm	83060060
8mm	83060080
10mm	83060100

DIFFERENT CHAIN GRADES & THEIR USAGE



Grade 30 – Proof Coil

Suitable for general purpose use such as security barriers, guard rails and load restraint. This medium duty chain is constructed from low carbon steel and is not suitable for lifting applications.

Grade 43 – High Test

Made from high carbon steel. Provides greater working load limits in comparison to Grade 30 chain. It is recommended for use in construction and agriculture where the larger working load limits are required. This chain is not recommended for lifting applications.

Grade 70 – Transport

Also called transport chain, Grade 70 chain is high strength heat treated carbon steel. It is recommended as a load restraint or tie down. Grade 70 typically has a gold finish for easy identification. This chain is not suitable for lifting applications.

Grade 80 – Alloy

Made of heat treated alloy steel. This material gives it a high strength to weight ratio. This chain is recommended for lifting, rigging and tie down applications.

Grade 100 – Alloy

Approximately 25% stronger than Grade 80 chain. This chain is recommended for overhead lifting applications.

Can't find the right chain?
Call Bishops with your request!

PLASTIC CHAIN



- Made of high density precision moulded polymer plastic
- Lightweight, floats and fade resistant (UV stabilised)
- Not recommended or certified for industrial lifting or other standard controlled usages
- Sold per metre
- Roll length: 40m
- Size: 6mm



Colour	Bishops Code
Red/White	55075147
Yellow	55075148

PROOF COIL CHAIN



- General purpose chain
- Hot dip galvanised
- **Not suitable for lifting applications**
- Sold per metre



Size	Bishops Code	Size	Bishops Code
3mm	82005030	13mm	82005130
4mm	82005040	16mm	82005160
6mm	82005060	20mm	82005200
8mm	82005080	24mm	82005250
10mm	82005100	-	-

SHORT LINK ANCHOR CHAIN



- Grade L
- Hot dip galvanised
- **Not suitable for lifting applications**
- Commonly used for moorings, anchoring and other marine applications
- Sold per metre



Size	SWL	Bishops Code
8mm	640kg	82006080
10mm	1,000kg	82006100
13mm	1,700kg	82006130
16mm	2,580kg	82006160

STAINLESS STEEL SHORT LINK CHAIN



- General purpose chain
- Stainless steel grade 316
- **Not suitable for lifting applications**
- Sold per metre



Size	Bishops Code
6mm	83005060
8mm	83005080
10mm	83005100



COMMERCIAL CHAIN & ROPE

MATERIAL HANDLING & LIFTING

HI-TENSILE TRANSPORT CHAIN

- Gold finish
- **Not suitable for lifting applications**
- Sold per metre
- Grade 70



Size	Bishops Code
6mm	81010078
8mm	81010080
10mm	81010100
13mm	81010130

TRANSPORT CHAIN ASSEMBLY KITS WITH GRAB HOOKS

- Supplied in a bucket
- Fitted with grab hooks each end
- **Not suitable for lifting applications**
- Grade 70
- Complies with AS/NZ 4344



Size	Bishops Code
8mm x 9m	81010208
10mm x 9m	81010210

CONTAINER BOLT SEALS

- For securing containers during storage or transport
- 200 per box



Item Code	Bishops Code
LKL0001	66590120

POLYPROPYLENE ROPE

- General purpose rope
- 3 strand, Z twist
- With blue tracer
- Lightweight and can float on water



Size	Bishops Code	Size	Bishops Code
4mm x 250m	81056040	16mm x 125m	81056160
6mm x 250m	81056060	20mm x 125m	81056200
8mm x 200m	81056080	24mm x 125m	81056240
10mm x 125m	81056100	32mm x 125m	81056320
12mm x 125m	81056120	-	-

POLYPROPYLENE BRAIDED ROPE



- Polypropylene will not mould, mildew or rot
- Resistant against fuel, oil and most acids and alkalis
- Suitable for a wide range of industrial applications
- Lightweight and high strength multi-filament
- UV treated
- Floats on water



Item Code	Strands	Dia.	Length	Colour	Bishops Code
30017	8	4mm	30m	Yellow/Red	81050001
230078	32	9mm	15m	Red/White/Blue	81050050

POLYPROPYLENE TWISTED ROPE



- Polypropylene will not mould, mildew or rot
- Is resistant against fuel, oil and most acids and alkalis
- UV treated to reduce degradation from sunlight
- Suitable for securing tarps and light loads
- Three strand construction makes it strong and resistant to kinking while still holding its shape
- Floats on water
- Diameter: 4mm
- Length: 30m
- Colour: Yellow/black



Item Code	Bishops Code
220002	81050020

POLYESTER BRAIDED ROPE



- Polyester is easy to handle and knot
- Braided, 32 strand
- High abrasion resistance
- High quality rope with a high breaking strength
- Suitable for most worksites
- Does not float in water
- Diameter: 8mm
- Length: 20m
- Colour: Black/red



Item Code	Bishops Code
240033	81050010

POLYESTER TWISTED ROPE



- Polyester is easy to handle and knot
- Twisted, three strand
- High abrasion resistance
- Does not float in water
- Diameter: 10mm
- Length: 15m
- Colour: white



Item Code	Bishops Code
140230	81050070

SILVER ROPE

- General purpose rope
- Super 3 strand, twisted



Size	Bishops Code	Size	Bishops Code
6mm x 300m	81054060	16mm x 125m	81054160
8mm x 200m	81054080	20mm x 125m	81054200
10mm x 125m	81054100	24mm x 125m	81054250
12mm x 125m	81054120	32mm x 125m	81054320

RATCHET TYPE LOADBINDERS WITH HOOKS

- Comes with a special safety locking device
- Supplied with a safety warning/instruction swing tag
- **Not suitable for lifting applications**
- Grade 70
- Complies to AS/NZS 4344.2001



Lashing Capacity	Size	Bishops Code
6,000kg	8mm	81040098
6,000kg	10mm	81040110
9,000kg	13mm	81040210

LEVER TYPE DOUBLE SWIVEL LOADBINDERS WITH GRAB HOOKS

- The double swivel lever style incorporates an extended pin stud design feature
- **Not suitable for lifting applications**
- Grade 70
- Complies to AS/NZS 4344.2001



Lashing Capacity	Size	Bishops Code
6,000kg	10mm	81040100
9,000kg	13mm	81040200

RATCHET TYPE CHAIN LOADBINDER

- Powerful ratcheting system pulls heavy loads with less effort
- Used for fixing heavy equipment
- Heavy gauge all-steel construction with corrosion resistant galvanised finish
- Drop forged with an enamel painted finish
- Dual solid steel gears distribute pulling force evenly
- Free wheel function for quick take up
- Quality grade 70 load chain
- Fitted with swivel grab hooks and can be fixed with multiple end fittings
- Durable mould grip handle for comfortable operation
- Easy and safe to use
- Suit 8mm chain
- Lashing capacity: 2,500kg



Bishops Code
81040092

HOW TO RESTRAIN A LOAD

It is Australian Law to ensure that all items being transported on a trailer, utility vehicle or truck are restrained properly.

Unrestrained items can cause serious damage to property, personal injury or death. If your load is not restrained properly you may get a fine or, for serious breaches, be prosecuted in court. Follow this guide to ensure your load is properly restrained.



What restraining methods are suitable for what loads?

When restraining lighter items such as garden trimmings, cover with a tarpaulin or netting. This will stop it being blown off in transit.

Heavier items such as white-goods and furniture should be fixed to the headboard to ensure that they do not fall over during transit, this includes heavy braking and while the vehicle is negotiating corners.

Small items such as tools should be contained within boxes, then if necessary strapped down. Larger tools, such as shovels or rakes, should be restrained by straps or a net if not adequately contained by the vehicle body.



Why Tie Down?

Tying down a load creates friction between the vehicle, load and the restraint keeping the load in place. To create adequate friction restraints need to be fastened tight to create an ample amount of tension. To tie down a load we suggest use of ratchet straps and/or webbing straps.

Avoid using rope as it does not create the same amount of tension as ratchet or webbing straps even though it feels tight. A secure load should be tied down from the top and any exposed sized.

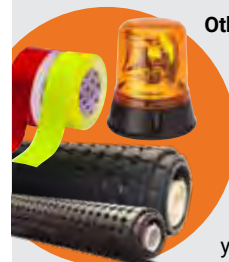

Other things to remember

- Your load must not cover your number plate, lights or reflectors.
- If any part of your load protrudes more than 1.2m behind your vehicle or trailer, or if it protrudes in a way that is not easily visible, a brightly coloured flag (red, red/yellow, or yellow) measuring at least 450 x 450mm should be fixed to the extreme end of the protrusion.
- If carrying such load at night, a red light or at least two reflectors must be attached to the extreme end of the protrusion.
- Items such as steel pipe can be slippery, to prevent slipping utilise rubber mats or wooden dunnage.
- Make sure that heavy items are not stacked on top of lighter items.



HOW TO USE A RATCHET STRAP



1 Insert loose end of strap into mandrel of ratchet



2 Pull strap through slot in mandrel



3 Pull slack out of strap to make strap tight



4 Crank the ratchet to desired tightening



5 Make sure strap stays in line with other to avoid tangling/locking



6 Lock handle down after tightening

HOW TO RELEASE A RATCHET STRAP



1 Pull trigger toward back handle



2 Open ratchet all the way



3 Webbing should release



4 Pull webbing out of mandrel



5 Pull trigger to unlock



6 Close ratchet back down

SNATCH STRAP

- 100% Nylon
- Reinforced eyes
- Capacity: 11t
- Size: 75mm x 9m



Item Code	Bishops Code
HU1024	80009050

4X4 RECOVERY KIT

- Essential items for any 4x4 recovery
- Includes:**
- 8t 9m MBS snatch strap
- 2 x 4.75t WLL bow shackles
- Pig grain leather recovery gloves & heavy duty storage bag



Item Code	Bishops Code
HU100K	80009030

RATCHET TIE-DOWN STRAPS

- Complies with AS/NZ 4380
- Blue



Capacity	Size	Bishops Code
750kg	25mm x 3m	80002010
750kg	25mm x 5m	80002020
750kg	25mm x 8m	80002040
2,500kg	50mm x 10m	80002340
5,000kg	75mm x 12m	80002350

WINCH & SNATCH RECOVERY KIT

- Includes:**
- 8t Snatch strap & snatch block
- 5t Winch extension strap
- 12t Tree protector strap
- 4.75t Bow shackles, gloves & damper



Item Code	Bishops Code
HU200K	80009040

HAND WINCHES

- Ratio 4:1
- Nylon belt
- Gear winch
- **Not suitable for lifting applications**

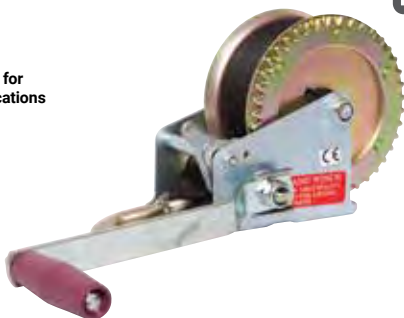

Pull Capacity	Bishops Code
450kg	81085300
1,000kg	81085310

DYNEEMA ROPE ELECTRIC 4X4 WINCH

- Dyneema® SK75 rope
- 3 Stage planetary gear train
- Water resistant
- Capacity: 4.3t
- 12V, 6hp
- IP67 Rated



Item Code	Bishops Code
HU9500R	81085325

3T TRUCK WINCH

- Clip-on
- Length: 12m
- Capacity: 3t



Bishops Code
80002420

STEEL CABLE ELECTRIC 4X4 WINCH

- Steel cable
- 3 Stage planetary gear train
- Water resistant
- Capacity: 4.3t
- 12V, 6hp
- IP67 Rated



Item Code	Bishops Code
HU9500S	81085330



HOW TO LIFT SAFELY

✓ Dos

✗ Don'ts

1

Lift as a team

Do lift bulky or heavy loads as a team. Doing so is smart and the safe way to work.

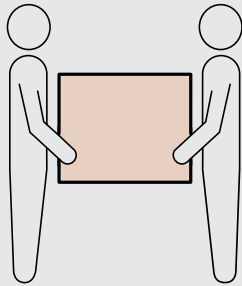

Don't lift bulky loads alone

Don't lift bulky or heavy loads alone. Doing so puts great stress on your lower back muscles and spine.

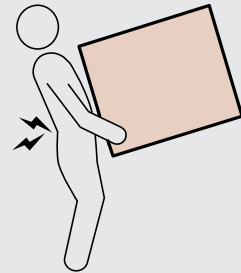

2

Turn your legs

Do move your legs and feet when turning or lowering the load. Avoid twisting at your waist.

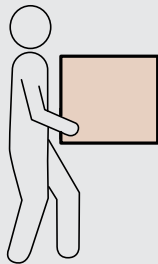

Don't twist when lifting

Don't twist when lifting, lowering, or carrying any load as this increases your risk of back injury.

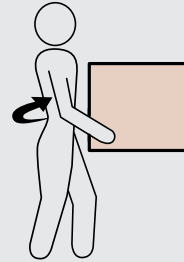

3

Use your legs

Do lift the load using your powerful leg and buttocks muscles. Your feet should be wide apart, head and back upright. Keep abdominal muscles tight and the load in close.

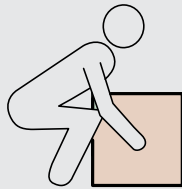

Don't use your back

Don't lift the load with your rear end high and your head low. Use your leg muscles, not your weaker lower back muscles.



4

Use equipment

Do use equipment like hand trucks, dollies or forklifts to do the heavy lifting. It's much less work and less risk of injury.



Don't lift heavy loads

Don't lift heavy loads when you can use equipment. It is less work and less stress on your lower back.

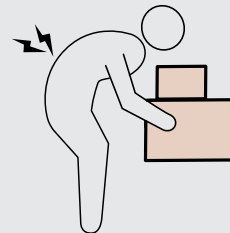

For more information or any safety related questions contact your Industrial Safety Experts today!
Call your local branch or visit www.bishopbros.com.pg

GET MORE AT BISHOPS ▶



BACK SUPPORT BELT

Page 80

CONTAINER RAMP

- Designed to attach to a standard container from ground level
- Can be used for vehicle loading on a raised dock
- Able to be fitted to a forklift for transport
- Features a self-levelling lip to help maintain full load capacity on uneven ground
- Safety yellow enamel finish
- SWL: 6,500kg
- 2,200(w) x 2,000(l)mm
- Weight: 275kg

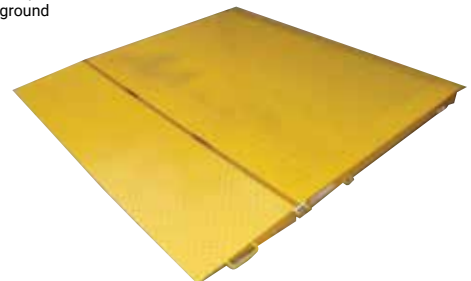

Bishops Code
66590115

P-HANDLE HAND TROLLEY

- Ergonomically designed P-handle for single handed control
- Large diameter pneumatic wheels make navigating rough ground or stairs a breeze
- Rubber protection on sides to prevent damage to load
- Fully welded frame for long life and ultimate strength
- Dimensions: 1,310(h) x 560(w)mm
- Shoe size: 215(l) x 355(w)mm
- Tyre diameter: 355mm (14")
- Capacity: 200kg



Item Code	Bishops Code
HT2402	84050101

STAIRCLIMBER HAND TROLLEY

- Safety ratchet and strap included
- 6" solid wheel assembly
- Shoe size: 435 x 230 x 9mm
- Dimensions: 560 x 1,520mm
- Capacity: 250kg
- Weight: 18kg



Item Code	Bishops Code
SCR115	84050102

HEAVY DUTY PLATFORM TROLLEY

- Heavy duty powder coated 4 wheel trolley
- All steel welded construction
- PU castors, front fixed and rear swivel with brake
- Dimensions: 1,030(l) x 700(w) x 970(h)mm
- Capacity: 900kg



Item Code	Bishops Code
	84050210

FOUR WHEEL CARGO TROLLEY

- Steel construction
- Surface is zinc and chrome plated with transparent powder coating
- Easy to handle lightweight trolley
- Basket folds down to allow for higher loads
- Four castor wheels provide smooth running
- 875(l) x 540(w) x 940(h)mm
- Load capacity: 130kg



Item Code	Bishops Code
	84050220

SCISSOR LIFT TROLLEY

- Suitable for use as a feeding table on assembly line
- Structural heavy duty steel construction
- Easy action foot operated hydraulic lift for raising table top to desired level
- Hand operated table descent control
- Over load-pass valve protects operator and pump
- Min. table height: 280mm
- Max. table lift height: 900mm
- Capacity: 500kg



Item Code	Bishops Code
SP500	84050350

DOUBLE OXY HAND TRUCK

- Robust powder coated construction
- Fully welded frame
- Solid shoe with wide lips
- Used for the storage and movement of "G" sized oxygen and acetylene gas cylinders
- 16" pneumatic wheels
- Height: 1,300mm
- Shoe: 250 x 560mm
- Load rating: 200kg



Item Code	Bishops Code
GBR002	84050110

OXYGEN/ACETYLENE CYLINDER TROLLEY

- Designed for use as trolley, lifting frame or use with a forklift
 - WLL: 200kg
 - Weight: 50kg
 - Available in other sizes and formats
- Specifications:**
- Full height (A): 1,800mm
 - Handle height (B): 1,280mm
 - Base plate (C) x (D): 625 x 240mm
 - Cage height (E): 600mm
 - Pocket width (F): 160mm



Item Code	Bishops Code
263200T	84050375



DRUM DOLLIES & LIFTERS

MATERIAL HANDLING & LIFTING

205L DRUM TROLLEY

- Suits 205L drums with diameter up to 660mm
- Platform is only 12mm off the floor making loading and unloading easy
- Heavy duty construction, made from 5mm steel sheeting
- Includes removable pivoting handle with drum tipper
- Chain for securing drum to the trolley
- Two large phenolic front wheels and one phenolic swivel back wheel
- Fully powder coated finish
- Load capacity: 545kg



Item Code	Bishops Code
TRL/55	68590040

DRUM DOLLY

- Suits 205L drum with a diameter up to 584mm
- Heavy duty construction, made from 3mm steel sheeting
- Wide steel cross base design for full support
- Firmly welded four heavy duty cast iron castors
- Powder coated finish
- Height: 165mm



Item Code	Bishops Code
BDL/140S	68590050

DRUM DOLLY

- Suitable for 205L/180kg drums
- Industrial quality steel construction
- Convenient and easy means of moving drums around the workshop, warehouse or production facility
- Reduces the physical effort of drum handling and provides a safer working environment
- Can convert an empty drum into a mobile container
- Includes four swivel castors



Item Code	
80100	

SPECIAL ORDER: PLEASE QUOTE ITEM CODE UPON ORDERING THIS PRODUCT

FORKLIFT DRUM LIFTER

- Designed for standard 205L steel drums
- Fully automatic clamping action enables safe and precise placement of drums without the operator having to leave the drivers seat
- Support arms are adjustable to ensure secure clamping
- Drum is gripped by pushing the arms against the drum centre and driving forward with the forklift.
- Arms will engage around the drum and lock under the rolling hoop when raised
- The heavier the load, the tighter the grip becomes
- Zinc plated finish
- 500kg SWL
- Load centre: 1375mm
- Horizontal centre of gravity: 760mm
- Vertical centre of gravity: 40mm
- Pocket size: 185 x 60mm
- Pocket centres: 420mm



Weight	Bishops Code
100kg	80090068

FORKLIFT DRUM LIFTERS

- Good field of vision allows the operator to continually observe the drum being handled
- The operator does not need to leave the drivers seat
- Unique beak design provides a high clamping force, even when travelling over uneven ground
- With few moving parts, this attachment requires no down time for repairs
- Suitable for standard 205L steel or plastic drums
- Contoured rest acts at a point low enough down the drum to prevent damage to the drum and its labelling
- Zinc plated finish
- Pocket size: 185 x 60mm

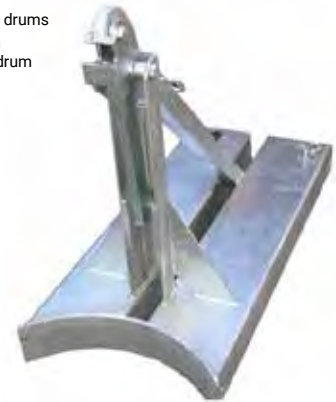

Description	SWL	Pocket Centres	Load Centre	Horizontal Centre of Gravity	Vertical Centre of Gravity	Weight	Bishops Code
Single	1,000kg	250mm	1,210mm	560mm	130mm	72kg	80090070
Double	1,500kg	600mm	1,250mm	580mm	175mm	95kg	80090072

GET MORE AT BISHOPS



HI-VIS JACKETS

Page 69

HOW TO SELECT A CASTOR

A number of factors go into selecting the right castor. Bishops have made it easy by explaining the different elements that you should take into consideration when making your decision.

Mount – Plate or Bolt?

Plated mounted castors mount directly to the bottom of the trolley, fixed with bolts. Bolt hole castors are mounted with a single bolt straight through the middle.

Tyre Material

Not all wheels are created equal. See below to see what material is suitable for your application, rated from 1 to 4 (1 being poor, 4 being excellent).

Plain Bearing consists of an axle sleeve that is connected to the wheel itself. The axle is fed through this and then turns around the axle sleeve. This creates a cost efficient bearing that under normal conditions will be corrosion resistant.

Roller Bearings are made by arranging a number of needle rollers around an axle tube. The needle rollers roll as the axle turns, creating friction-free movement and excellent mobility.

Precision Bearings consist of balls that run between an inside and outside ring, creating a bearing that performs under heavy loads and high speeds. These bearings are high quality, offering maximum mobility

	Wheel Material	Suitable Surfaces	Durability	Shock Absorbency	Capacity	Push Effort	Floor Protection
	Polyurethane	Versatile, works well on most surfaces	3	3	4	3	3
	Grey/Blue Rubber	Performs best on quality, clean flooring	3	3	3	2	4
	Black Rubber	Suits industrial areas and concrete	2	4	3	2	3
	Pneumatic	Unusual, irregular or unsealed surfaces, such as outdoors	3	4	2	1	4
	Nylon	Smooth surfaces such as concrete	3	2	4	4	2
	Cast Iron	Uneven surfaces, or any surface that may be susceptible to heat	4	1	4	4	1

CALCULATE LOAD CAPACITY & WHEEL SIZE

Load Capacity

To calculate the load capacity necessary per castor use the following formula:

$$\frac{\text{Max Load + Weight of Trolley}}{\text{Number of Castors} - 1}$$

Wheel Size

The larger the wheel, the easier it will roll, reducing the overall push effort.

PLASTIC FURNITURE CASTORS

- Swivel type
- Dual wheel
- 50mm wide
- Thread: 8 x 19mm (5/16" x 3/4")
- Sold individually



Item Code
S2720

Bishops Code
84040050



CASTORS, LOAD SKATES & WHEELBARROWS

MATERIAL HANDLING & LIFTING

POLY CASTORS

- Heavy duty castor suitable for applications that require a higher carrying capacity
- Double ball bearings
- Orange polyurethane wheel
- Sold individually



Description	Diameter x Width	Capacity	Bishops Code
Swivel	150 x 50mm	400kg	84025150
Swivel	200 x 50mm	450kg	84025200
Swivel with Brake	150 x 50mm	400kg	84028150
Swivel with Brake	200 x 50mm	400kg	84028200
Fixed	150 x 50mm	400kg	84020150
Fixed	200 x 50mm	450kg	84020200

INDUSTRIAL NYLON CASTORS

- Medium duty castor suitable for most applications, environments and surfaces
- Double ball bearings
- Steel
- White/cream wheel
- Sold individually



Description	Diameter x Width	Capacity	Bishops Code
Swivel	75 x 30mm	50kg	84015075
Swivel	100 x 30mm	70kg	84015100
Swivel	125 x 30mm	100kg	84015125
Swivel	150 x 50mm	150kg	84015150
Swivel	200 x 50mm	230kg	84015200
Swivel with Brake	100 x 30mm	70kg	84018100
Swivel with Brake	125 x 30mm	100kg	84018125
Swivel with Brake	150 x 50mm	150kg	84018150
Swivel with Brake	200 x 50mm	230kg	84018200
Fixed	75 x 30mm	50kg	84010075
Fixed	100 x 30mm	70kg	84010100
Fixed	125 x 30mm	100kg	84010125
Fixed	150 x 50mm	150kg	84010150

INDUSTRIAL RUBBER CASTORS

- Medium duty castor suitable for most applications, environments and surfaces
- Central precision ball bearing
- Steel
- Solid black wheel
- Sold individually



Description	Diameter x Width	Capacity	Bishops Code
Swivel	75 x 30mm	50kg	84035075
Swivel	100 x 30mm	75kg	84035100
Swivel With Brake	75 x 30mm	50kg	84038075
Swivel With Brake	100 x 30mm	75kg	84038100
Fixed	75 x 30mm	50kg	84030075
Fixed	100 x 30mm	75kg	84030100

LOAD SKATE

- Low profile load movers
- Suitable for moving a wide range of heavy equipment including machinery and bridge structures



Capacity	Bishops Code	Capacity	Bishops Code
1,500kg	84050056	12,000kg	84050082
6,000kg	84050060	18,000kg	84050084
8,000kg	84050080	-	-

WHEELBARROWS

BLACK JACK

- Pneumatic wheel on the front
- Powdercoated steel handles
- Strong upright supports built into the frame to keep the tray in place
- Rubber grips on handles
- Poly and steel trays available
- Colours may vary
- Capacity: 170L



Description	Bishops Code
Wheelbarrow With Poly Tray	63580070
Wheelbarrow With Steel Tray	63580072

HEAVY DUTY CONTRACTORS WHEELBARROW

- Heavy duty tubular steel frame
- Wide pneumatic wheels
- Wheel size: 400 x 135mm
- Steel rim: 25mm bore
- Steel handles with soft contoured handle grips
- Tray capacity: 100L



Item Code	Bishops Code
190-93-08769	63580068

DOUBLE WHEEL PALLET TROLLEYS

- Suitable for industrial warehouses and workshops when a forklift is not needed
- Double wheels allow optimal manoeuvrability
- Capacity: 2,500kg



Max. Lift Height	Min. Fork Height	Overall Fork Width	Individual Fork Width	Fork Length	Bishops Code
200mm	85mm	550mm	160mm	1.15m	84050500
190mm	75mm	685mm	160mm	1.22m	84050600

OFF ROAD PALLET TROLLEYS

- Suitable for rough terrain
- Rubber wheels
- Fork length: 800mm
- Capacity: 1,500kg



Bishops Code
84050650

STACKER PALLET TRUCK

- Suitable for indoor use
- Min. fork height: 85mm
- Max. lift height: 2.5m
- Cornering radius: 1.35m
- Lift speed (full/no load): 20/22mm per sec
- Decline speed (full/no load): 143/53mm per sec
- Overall width of forks: 550mm
- 1,660 x 860 x 1,838mm
- Capacity: 1,000kg
- Weight: 300kg



Item Code SDJ1025 Bishops Code 84050860

FORKLIFT EXTENSION SLIPPERS

- Designed with a slim profile to extend the versatility of your lift truck
- Constructed from high tensile grade steel
- Zinc plated finish for added corrosion protection
- High safe working load (SWL) rating
- Fitted with rating plate
- Designed and manufactured in accordance with AS2359.15.
- Supplied with toggle locking pins and instructions
- Length: 2,100mm
- Max. Tine Size: 155 x 55mm
- Min. Tine Length: 1,260mm
- SWL Per Pair at 5,000mm
- Load Centre: 5,000kg
- Weight of pair: 86kg



Bishops Code
80090058

FIXED FORKLIFT JIB – SHORT

- Affordable, general purpose jib
- Able to manoeuvre in confined spaces
- This slip-on forklift attachment is held to the forklift by a safety chain
- Zinc plated finish
- 4,500kg SWL at shortest extension
- 750kg SWL at longest extension
- Extension range: 670–1,925mm
- Load centre: 670mm
- Pocket size: 185 x 65mm
- Pocket centres: 290 mm
- Horizontal centre of gravity: 735mm
- Vertical centre of gravity: 120mm
- Weight: 95kg



Bishops Code
80090052

TILT FORKLIFT JIB – LONG

- Extremely versatile with 8 hook positions and three different angle positions
- With wide pockets suitable for forklifts with special hydraulic tine positioners
- Slip-on attachment is held to the forklift by a safety chain
- Allows extra height to 2.51m
- 2.23m overall length when closed
- Zinc plated finish
- 2,500kg SWL at shortest extension
- 240kg SWL at longest extension
- Extension range: 1,085–3,660mm
- Load centre: 1,085mm
- Pocket size: 165 x 65mm
- Pocket centres: 740mm
- Horizontal centre of gravity: 1,350mm
- Vertical centre of gravity: 380mm
- Supplied with safety swivel hook and shackle
- Weight: 205kg



Bishops Code
80090054



WORK PLATFORMS & STORAGE CAGES

MATERIAL HANDLING & LIFTING

CKM CONCRETE KIBBLE

- Lightweight, yet heavy duty
- Adjustable chute allows discharge from the bottom or side of unit
- Lever operated from either side, for flexibility of use
- Fitted with fork pockets for transport around the work site
- Hydraulic Kibble Option (HPP-REMOTE) available to remotely control kibble
- Enamel paint finish
- Volume Capacity: 1.0 cu.m
- Working Load Limit 3,000kg
- Filling Height 1,320mm
- Overall Dimensions: 1,760 x 1,655 x 1,705mm
- Weight: 320kg



Bishops Code
80090066

BAR SIDED FORKLIFT WORK PLATFORM

- Suitable for two persons maximum
- Designed to carry out tasks of short duration such as maintenance or stocktake
- The use of this platform on a forklift truck should not be considered if the capacity of that forklift is less than 1,800kg for a counterbalanced type or 1,080kg for a reach type
- Zinc plated finish
- 250kg SWL
- Cage size: 1,154(w) x 1,064(d) x 1,000(h)mm
- Overall height: 2,000mm
- Load centre: 600mm
- Pocket size: 160 x 60mm
- Pocket centres: 640mm
- Horizontal centre of gravity: 550mm
- Vertical centre of gravity 600mm
- Weight: 110kg
- Manufactured strictly in accordance with Australian Standard AS 2359.1
- Supplied with slipper locking pins



Bishops Code
80090010

CRANE CAGE WORK PLATFORM – OPEN TOP

- Suitable for a maximum of four people
- Work performed in this cage shall be limited to special tasks of short duration in situations where necessary to elevate personnel where it is not practicable to erect scaffolds or use a specially designed device
- Fork arm slippers are provided for transport purposes only
- Zinc plated finish
- 500kg SWL
- 1,200(w) x 1,100(d) x 1,000(h)mm
- Weight: 270kg
- Designed strictly in accordance with Australian Standard AS 1418.17
- Supplied with a load test certificate, instructions for usage, risk control measures, workcover registration and lifting chains



Bishops Code
80090032

CRANE CAGE WORK PLATFORM – MESH TOP

- Suitable for a maximum of four people
- Work performed in this cage shall be limited to special tasks of short duration in situations where necessary to elevate personnel where it is not practicable to erect scaffolds or use a specially designed device
- Fork arm slippers are provided for transport purposes only
- Zinc plated finish
- 500kg SWL
- 1,200(w) x 1,100 (d) x 2,150(h)mm
- Weight: 310kg
- Designed strictly in accordance with Australian Standard AS 1418.17
- Supplied with a load test certificate, instructions for usage, risk control measures, workcover registration and lifting chains



Bishops Code
80090031

PALLET CAGE

- Designed for safe storage and transport of loose or packaged goods
- Side panels are mounted to a standard 1,165 x 1,165mm hardwood pallet
- Can be transported by forklift or pallet trolley
- Can be stacked up to 4 high when empty and 2 high when loaded
- Front drop down gate and rear hinged gate are both removable and are able to be opened for easy access, even when stacked
- Zinc plated finish
- Load capacity: 2,000kg
- 1,165(w) x 1,165(d) x 754(h)mm
- Weight: 75kg (including pallet)



Bishops Code
80090030

CRANE BRICK CAGE

- Designed to convey pallets of bricks or similar loose products safely to a work location via overhead crane
- Suitable for 1,200mm square pallets and up to 1,500mm overall height
- 4 point lift
- Tine storage when not hoisting
- Zinc plated finish
- 2,000kg SWL
- Internal dimensions: 1,240(w) x 1,240(d) x 1,500(h)mm
- Weight: 255kg
- Chains not included



Bishops Code
80090026

GOODS CAGE

- Designed to safely store and transport loose or palletised goods by crane or forklift
- Suits a 1,200mm square pallet
- Fully opening front gate for easy loading and unloading of palletised goods
- Stacking feet allow cages to be stacked 3 high when empty or 2 high when loaded
- Fitted with 4 point lift crane lugs and fork stirrups
- Optional Lifting Frame (CSPN-CL) enables single point lifting where head height is an issue
- Zinc finish
- Capacity: 1t



Item Code
CSPN-1T

Bishops Code
80090024

FORKLIFT GOODS CAGE

- Designed as a storage and transport cage suitable for furniture and white goods
- A hinged ramp is standard allowing furniture trolleys access into the cage
- Locking the ramp in the vertical position and attaching the two safety chains across the front secures goods inside the cage
- Painted enamel finish
- 1,000kg SWL
- Load centre: 600mm
- Pocket size: 160 x 60mm
- Pocket centres: 644mm
- Horizontal centre of gravity: 600mm
- Vertical centre of gravity: 300mm
- 1,200(w) x 1,200(d) x 1,000(h)mm
- Weight: 150kg
- Supplied with slipper locking pins
- Manufactured strictly in accordance with Australian Standard AS 2359.1
- Not designed or certified to convey personnel



Bishops Code
80090022

PLASTIC BUCKETS

- General purpose white bucket
- Comes complete with lid and handle



Size	Bishops Code	Size	Bishops Code
5L	62576052	15L	62576054
10L	62576053	20L	62576055

STACKABLE STORAGE CONTAINERS

- Heavy duty plastic
- Suitable for tools, toys and general storage
- Comes with lid
- Clear



Item Code	Capacity	Size	Bishops Code
Q-60665	35L	465(l) x 335(w) x 250(h)mm	84510105
Q-60667	50L	510(l) x 360(w) x 276(h)mm	84510110
Q-60668	75L	630(l) x 435(w) x 360(h)mm	84510115

GET MORE AT BISHOPS ▶



SAFETY HARNESSSES

Page 28

BULKER BAG

- 4 loop pickup points
- Top and bottom spout
- Capacity: 1,500kg
- 100(l) x 100(w) x 180(h)cm



Item Code	Bishops Code
91060010	80090060

POLYWEAVE BAG

- High strength durable bags
- Size: 965(l) x 585(w)mm



Item Code	Bishops Code
405791	66020110

IBC BULK STORAGE CONTAINER

- Bulk liquid storage container
- HDPE tank with EVOH permeation barrier
- Galvanised steel pallet frame
- Capacity: 1,000L



Item Code	Bishops Code
1297635	62022140

PARTS BINS

- Small parts storage bins
- UV protected plastic
- Blue



61072565



61072575

Item Code	Style	Size	Bishops Code
IH1000BLU	N5	60(h) x 100(w) x 115(d)mm	61072550
IH1001BLU	N10	85(h) x 100(w) x 170(d)mm	61072555
IH1002BLU	N20	125(h) x 135(w) x 225(d)mm	61072560
IH1003BLU	N30	165(h) x 205(w) x 280(d)mm	61072565
IH1004BLU	N40	165(h) x 410(w) x 280(d)mm	61072570
IH1006BLU	N60	165(h) x 410(w) x 440(d)mm	61072575



DANGEROUS GOODS STORAGE CABINETS

FLAMMABLE LIQUID STORAGE CABINET

- Designed for use with all Class 3 liquids
- 3-points self latching facility
- Ventilation ports with built-in flame arrestors
- Continuous piano hinge ensures smooth door closure
- Built-in ground connector
- Powder coated finish inside and out
- Sequentially closing doors
- Made from double-skin 1.2mm zinc coated steel
- Cabinets come with all required signage attached
- Full instructions attached to the inside of the door
- Complies with the Australian Standard AS1940-2004 for the storage of flammable and combustible liquids

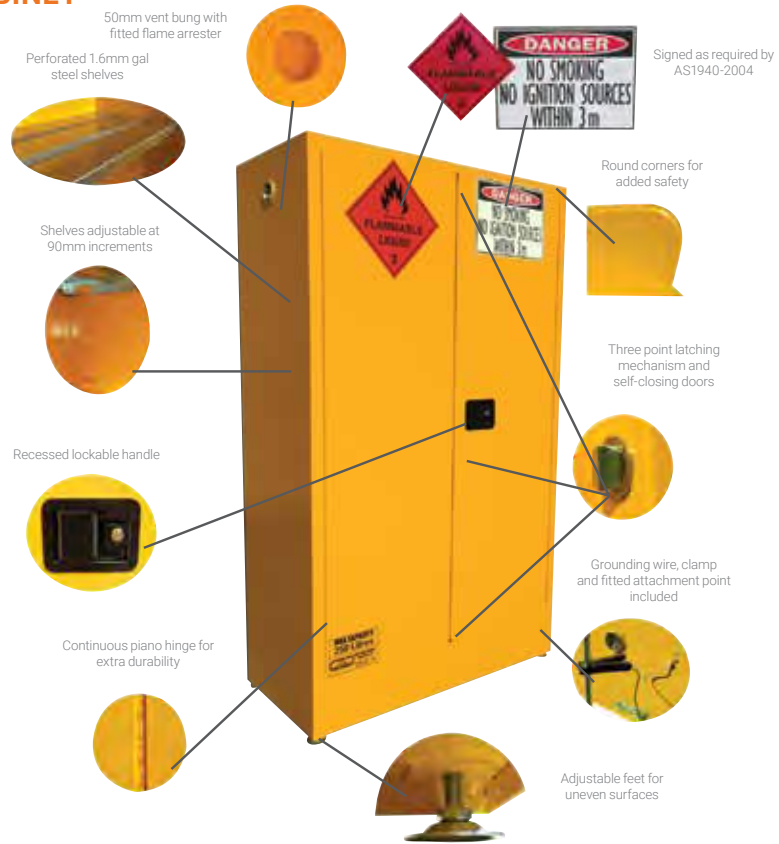

Item Code	Holds	No. of Doors	No. of Shelves	Capacity	Height	Width	Depth	Weight	Bishops Code
BCFLS250LE	12 x 20L Cans	1	3	350L	1,825mm	760mm	830mm	196kg	55080176

FLAMMABLE STORAGE UNITS

- Flammable Safety Storage Cabinets provide a safe, close-by, secure and time-saving method for storing all types of dangerous materials and help you to maintain good housekeeping practices
- All Justrite cabinets are fire tested to comply with the FM Approved, they also not only comply, but exceed Australian Standard AS 1940
- They help companies by providing product near to the workplace thus avoiding the time consuming and often risky practice of collecting from an outside storage facility



Item Code	Capacity	Shelves	Doors	Size
AU25602	350L, 15 x 20L Drums	3	2	1760 x 870 x 870mm
AU25452	250L, 9 x 20L Drums	3	2	1,760 x 1,100 x 465mm
AU25302	160L, 6 x 20L Drums	2	2	1,230 x 1,100 x 465mm
AU25748	100L	2	2	800 x 920 x 565mm
AU25712	60L	2	1	1,005 x 595 x 465mm
AU25714	30L	2	1	800 x 595 x 465mm
AU25304	110L	2	1	1,230 x 670 x 465mm
AU25308	170L	3	1	1,760 x 670 x 465mm

SPECIAL ORDER: PLEASE QUOTE ITEM CODE UPON ORDERING THIS PRODUCT

CLASS 3 INDOOR SAFETY CABINETS



- For indoor storage of class 3 flammable or combustible liquids
- Double wall construction with 40mm thermal barrier
- Vent ports with integral flash arrestors on each side
- Self-closing doors fitted with three point self-latching system and adjustable hydraulic door closure
- Flush mount handle with key lock
- Adjustable shelves plus fixed base shelf
- Built-in spill containment bund with suspended perforated floor
- Durable yellow powder coated finish
- Grounding connector included
- Adjustable screw-in feet allow the cabinet to be elevated to reduce corrosion or for levelling on uneven surfaces
- Appropriate safety and warning signage fitted in accordance with Australian Standards
- Complies with AS1940-2017



Item Code	Capacity	Doors	Shelves	External Dimensions	Bishops Code
SCIRF30	30L	1	2	600(w) x 475(d) x 800(h)mm	55080171
SCIRF60	60L	1	2	595(w) x 475(d) x 1,005(h)mm	55080172
SCIRF100	100L	2	2	1,100(w) x 510(d) x 800(h)mm	55080173
SCIRF160	160L	2	2	1,110(w) x 510(d) x 1,305(h)mm	55080174
SCIRF250	250L	2	3	1,115(w) x 520(d) x 1,850(h)mm	55080175
SCIRF350	350L	2	3	1,110(w) x 750(d) x 1,850(h)mm	55080177

CORROSIVE SUBSTANCE STORAGE CABINETS



- Polyethylene tray on each shelf to collect any accidental spillages
- Designed to withstand fire these cabinets provide a safe environment to store most corrosive chemicals
- Polyethylene Cabinets suitable to store chemicals such as Phenol, Nitric Acid, Sulphuric Acid or other substances with highly corrosive vapours



Item Code	Capacity	Shelves	Doors	Size
AU25602B	350L, 15 x 20L Drums	3	2	1,760 x 870 x 870mm
AU25452B	250L, 9 x 20L Drums	3	2	1,760 x 1100 x 465mm
AU25302B	160L, 6 x 20L Drums	2	2	1,230 x 1100 x 465mm
AU25748B	100L	2	2	800 x 920 x 565mm
AU25712B	60L	2	1	1,005 x 595 x 465mm
AU25714R	30L	2	1	800 x 595 x 465mm

POLYETHYLENE CABINETS

AU24180	90L	2	2	890 x 920 x 565mm
AU25748 Polv	100L	2	2	720 x 935 x 400mm

SPECIAL ORDER: PLEASE QUOTE ITEM CODE UPON ORDERING THIS PRODUCT

CLASS 8 INDOOR SAFETY CABINETS



- For indoor storage of class 8 corrosive substances
- Double wall, zinc anneal steel construction with 40mm thermal barrier and vent ports with integral flash arrestors
- Durable external protective finish – UV stabilised high gloss polyester powder finish (blue) in accordance with AS4506-2005, Metal finishing – Thermoset powder coatings
- Built-in spill containment bund with suspended perforated floor
- Three point latching, sequential self-closing doors with hydraulic closure and flush mount handle with key lock
- Adjustable shelves plus fixed base shelf
- Shelves are galvanised steel and perforated to permit free air movement in accordance with AS3780-2008, section 4.6.4 (c)
- Shelves are lined with poly trays for additional corrosion resistance
- Grounding connector included
- Adjustable screw-in feet allow the cabinet to be elevated to reduce corrosion or for levelling on uneven ground
- Appropriate safety and warning signage fitted in accordance with Australian Standards
- Complies with AS3780-2008, 'The storage and handling of corrosive substances'



Item Code	Capacity	Doors	Shelves	External Dimensions	Bishops Code
SCIRC60	60L	1	2	595(w) x 475(d) x 1,005(h)mm	55080162
SCIRC100	100L	2	2	1,100(w) x 510(d) x 800(h)mm	55080163
SCIRC160	160L	2	2	1,100(w) x 510(d) x 1,305(h)mm	55080164
SCIRC250	250L	2	3	1,115(w) x 520(d) x 1,850(h)mm	55080165

CLASS 6 INDOOR SAFETY CABINETS



- For indoor storage of class 6 toxic substances
- Double wall, zinc anneal steel construction with 40mm thermal barrier and vent ports with integral flash arrestors
- Highly durable external protective finish – UV stabilised polyester powder finish in accordance with AS4506-2005, Metal finishing – Thermoset powder coatings
- Integral spill containment bund with suspended perforated floor
- Three point latching, sequential self-closing doors with hydraulic closure and flush mount handle with key lock
- Two adjustable shelves plus fixed base shelf
- Shelves are galvanised steel and perforated to permit free air movement
- Shelves are lined with poly trays for additional corrosion resistance
- Grounding connector included
- Adjustable screw-in feet allow the cabinet to be elevated to reduce corrosion or for levelling on uneven ground
- Appropriate safety and warning signage fitted in accordance with Australian Standards
- Complies with AS4452-1997, 'The storage and handling of toxic substances'



Item Code	Capacity	Doors	Shelves	External Dimensions	Bishops Code
SCIRT60	60L	1	2	595(w) x 475(d) x 1,005(h)mm	55080178
SCIRT250	250L	2	2	1,115(w) x 520(d) x 1,850(h)mm	*SCIRT250

*** - SPECIAL ORDER: PLEASE QUOTE ITEM CODE UPON ORDERING THIS PRODUCT**

GET MORE AT BISHOPS

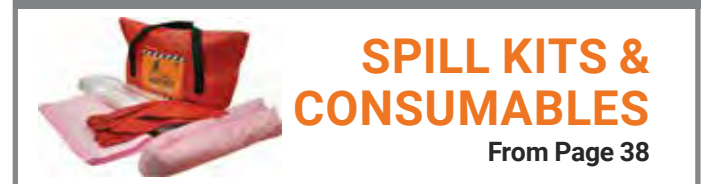

SPILL KITS & CONSUMABLES
From Page 38

GAS BOTTLES STORAGE CAGE

- Secure storage cage suitable for gas cylinders
- Perfect for construction sites and mines
- Lockable gate, mesh sides and roof sheeting ensure cylinder and gear security
- Fitted with a 4 point crane lift and forklift pockets underneath for transport
- Internal loadbinder prevents cylinder movement during transport
- Sheet metal roof for weather protection
- Zinc plated finish
- 750kg SWL
- Pocket size: 165 x 65mm
- Pocket centres: 665mm
- Horizontal centre of gravity: 515mm
- Vertical centre of gravity: 700mm
- 1,030(w) x 1,030(d) x 1,928(h)mm



Weight	160kg	Bishops Code	84520110
---------------	-------	---------------------	----------



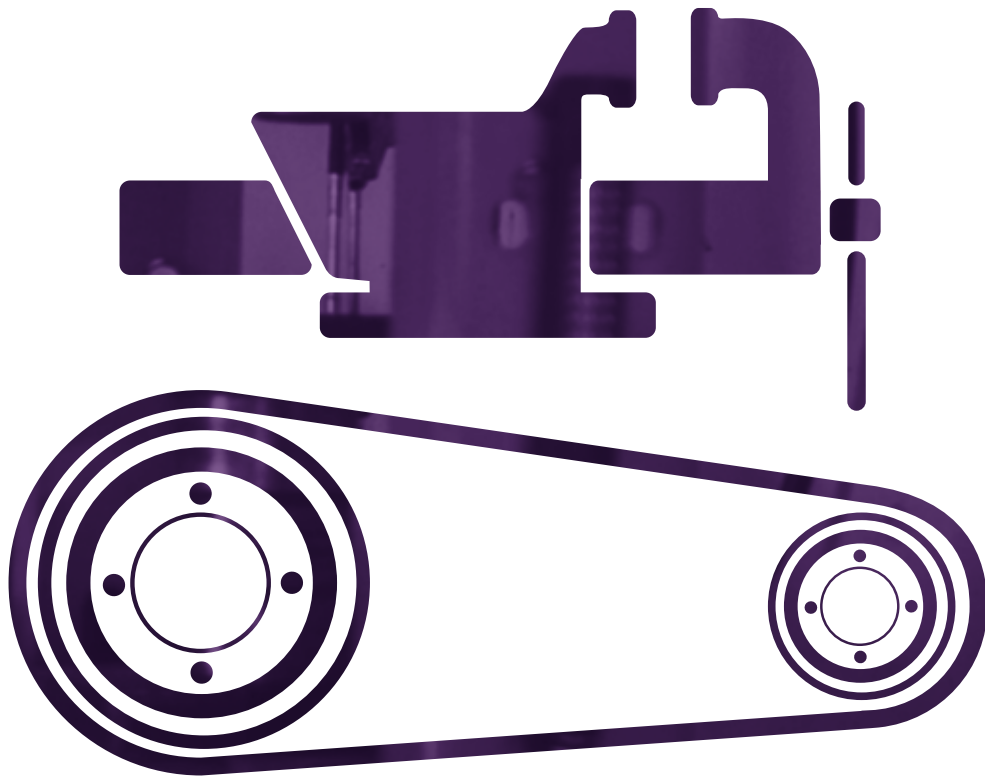

08

WORKSHOP, MACHINERY & CONSTRUCTION EQUIPMENT

WORKSHOP MACHINERY

Generators.....	324-325
Petrol & Diesel Engines.....	326
Water Pumps.....	326
Trash & Transfer Pumps.....	326-327
Air Compressors.....	327-330
Fans & Ventilation.....	331
Parts Washing Tank.....	331
Bench Lathes.....	332
Hydraulic Presses.....	333

WORKSHOP TOOLS & EQUIPMENT

Forged Anvil.....	333
Tube & Pipe Benders.....	333-334
Bench Vices.....	334-336
Pipe Vices & Stands.....	336

CONSTRUCTION MACHINERY & EQUIPMENT

Bricklayers Line & Flagging Tape.....	337
Plate Compactors.....	338
Tamping Rammers.....	339
Rollers & Concrete Mixers.....	339-340
Concrete Vibrators & Pokers.....	340
Drive Units & Submersible Pumps.....	340-341
Concrete Finishing Tools.....	341-342
Trowel Machines.....	342
Petrol Breaker.....	342
Brick, Floor & Band Saws.....	342-343
Lighting Tower.....	343

GARDENING & LANDSCAPING

Backpack Sprayer & Mistblower.....	343
------------------------------------	-----



PETROL GENERATORS

WORKSHOP, MACHINERY & CONSTRUCTION EQUIPMENT

2 STROKE PETROL GENERATOR – 650W

- Single phase
- 1.1hp
- 2 stroke
- 3,000/3,600rpm
- 0.65kW
- 650W
- 220V
- Rated current: 3.7amp
- Yangma IE45F engine
- Frequency: 50/60Hz
- Recoil start
- Noise level: 64dB
- Air cooled
- Emergency low oil warning
- 385(l) x 320(w) x 330(h)mm



Description	Bishops Code
YM950L 2 Stroke Petrol Generator	74010020

PETROL GENERATOR – 2KW

- Single phase
- 6.5hp
- 4 stroke
- 3,000/3,600rpm
- 2.0/2.5kW
- 2,000W
- 240V
- Rated current: 10amp
- Yangma 168FG engine
- Frequency: 50Hz
- Recoil start
- Noise level: 65dB
- Emergency low oil warning
- Overload protection
- Large muffler for quiet operation
- Open frame design
- 600(l) x 430(w) x 485(h)mm



Description	Bishops Code
YM2500LQ Petrol Generator	74020020

PETROL GENERATOR – 3KW

- Single phase
- 4hp
- 4 stroke
- 3,000/3,600rpm
- 3.0/3.3kW
- 3,000W
- 240V
- Rated current: 9.3amp
- Yangma 173FG engine
- Frequency: 50/60Hz
- Recoil start
- Noise level: 65db
- Emergency low oil warning
- Overload protection
- Large muffler for quiet operation
- Open frame design
- 680(l) x 510(w) x 540(h)mm



Description	Bishops Code
YM3500LQ Petrol Generator	74020030

PETROL GENERATORS



- Single cylinder, 4 stroke OHV engine
- Manual start
- Frequency: 50/60Hz
- Connect two generators together using the parallel kit
- DW2000I:**
 - Rated output: 1.7KVA (@ 50Hz/kW), 2.0KVA (@ 60Hz/KW)
 - Gross weight: 24.5kg
- DW3000I:**
 - Rated output: 2.6KVA (@ 50Hz/kW), 3.0KVA (@ 60Hz/KW)
 - Gross weight: 36kg
 - Two wheels for easy mobility



Item Code	Wattage	Displacement	Speed	Tank Capacity	Bishops Code
DW2000I	2kW	105.6cc	4,500rpm	3.2L	74072200
DW3000I	3kW	171cc	4,200rpm	4.2L	74072205

PETROL GENERATOR – 5KW

- Single phase
- 6.7hp
- 4 stroke
- 3,000/3,600rpm
- 5.0kW
- 5,000W
- 240V
- Rated current: 12V/8.3amp
- Yangma 188FG engine
- Frequency: 50/60Hz
- Recoil or electric start
- Noise level: 70–74dB
- Emergency low oil warning
- 680(l) x 510(w) x 540(h)mm



Description	Bishops Code
YM6500LQ Petrol Generator	74020050

6.5KVA PORTABLE PETROL GENERATOR

- WN13 Wacker Neuson engine
- Heavy duty steel bar frame
- Wheel kit and foldable handles
- Diversion trench fuel tank design
- Single phase
- 4 stroke
- Rated speed: 3,000rpm
- Max. output: 5.5kW
- Rated voltage: 220V
- Frequency: 50Hz
- 683(l) x 540(w) x 562(h)mm



Item Code	Bishops Code
630393	74020052

5KW DIESEL GENERATOR

- Silenced
- Single phase
- Electric start
- 186F engine
- Frequency: 50/60Hz
- 230/240V
- 3,000/3,600rpm
- Output: 4.2/5.0kW



Item Code	Bishops Code
6GF-LDE	74050052

6KW GENSET/YANMAR DIESEL GENERATOR

- Earth leakage circuit breaker (ELCB)
- Low oil cut out function
- Single phase
- 3,000rpm
- 230V
- Frequency: 50Hz
- 6kW
- 5,400W
- Yanmar L100N engine
- 10hp motor
- Recoil start
- Tank capacity: 5.5L
- 820(l) x 580(w) x 610(h)mm
- Dry weight: 125kg



Model	Bishops Code
MG 6000 YE	74050060

DIESEL GENERATORS

- Single phase
- 3,000/3,600rpm
- 240V
- Rated current: 12V/8.3amp
- Frequency: 50/60Hz
- Noise level: 70-74dB
- Single cylinder vertical
- Air cooled, direct injection
- Emergency low oil warning



74050030

Description	kW	Wattage	Engine	Motor	Noise Level	Dimensions	Bishops Code
Recoil Start	2kW	2,000W	Yangma 170FG	4hp	79dB	595(l) x 410(w) x 500(h)mm	74050010
Recoil Start	3kW	3,000W	Yangma 178FG	7hp	74dB	690(l) x 470(w) x 570(h)mm	74050030
Recoil Start	5kW	5,000W	Yangma 186FG	9hp	79dB	720(l) x 480(w) x 650(h)mm	74050050
Electric Start	4kW	5,000W	Yangma 186FG	9hp	79dB	720(l) x 480(w) x 650(h)mm	74060050

SILENCED DIESEL GENERATORS

- Frequency: 50Hz
- Engine speed: 1,500rpm



Model	KvA	Engine	Phase	Dimensions	Bishops Code
SG10KS-AU	10kVA	Kubota D1105-BG	1 Phase	1,600(l) x 790(w) x 1,163(h)mm	74072140
SG18KS-AU	18kVA	Kubota D1703-BG	1 Phase	1,700(l) x 846(w) x 1,145(h)mm	74072150
QSV20KS-AU	20kVA	Kubota V2203-BG	3 Phase	1,650(l) x 866(w) x 1,146(h)mm	74072160
QSV43CS-AU	45kVA	Cummins 4BT3.9-G1	3 Phase	2,300(l) x 946(w) x 1,735(h) mm	74072170
QSV60CS-AU	60kVA	Cummins 4BTA3.9-G2	3 Phase	2,300(l) x 946(w) x 1,720(h) mm	74072180



ENGINES & WATER PUMPS

GENERATOR CHANGEOVER SWITCHES

- Switch and panel



Item Code	Description	Bishops Code
1000026044	AP63A To Suit Model SDP10K5S-AU	74085145
1000026045	AP80A To Suit Model SDP15K5S-AU	74085150
1000080658	AP40A To Suit Model DP20K5S-AU	74085155
1000074966	AP63A To Suit Model DP45P5S-AU	74085160
1000074967	AP80A To Suit Model DP60P5S-AU	74085170

PETROL & DIESEL ENGINES

- Air cooled
- Manual start



Engine	Motor	Bishops Code	Engine	Motor	Bishops Code
YM 168F-2 Petrol	6.5hp	74210065	YM 178FS Diesel	6.0hp	74230042
YM 170F Diesel	4.0hp	74230020	YM 186F Diesel	9.0hp	74230060
YM 178F Diesel	6.0hp	74230040	YM 186FG3 Diesel	9.0hp	74230460

PETROL WATER PUMPS

- High pressure pump
- Suitable for irrigation, gardening and water draining
- Lightweight and portable
- Recoil start
- Maximum suction head: 8m
- 4 stroke, YM 168F-2 engine



74410020



74410030

Engine	Power	Port Size	Head	Capacity	Displacement	Self-Priming Time	Speed	Dimensions	Weight	Bishops Code
YM 168F-2	4,000W/5.5hp	2"	26m	25m ³ /h	163cc	180s/4m	3,600rpm	480(l) x 430(w) x 400(h)mm	20kg	74410020
YM 168F-2	4,800W/6.5hp	3"	28m	60m ³ /h	196cc	60s/4m	3,600rpm	505(l) x 415(w) x 470(h)mm	31kg	74410030

DIESEL WATER PUMPS

- High pressure pump
- Suitable for irrigation, gardening and water draining
- Lightweight and portable
- Recoil start
- Maximum suction head: 8m



74440020



74430030

Engine	Power	Port Size	Max. Head	Capacity	Displacement	Self-Priming Time	Speed	Dimensions	Weight	Bishops Code
YM 170F	2.5kW/3.4hp	2"	26m	36m ³ /h	211cc	70s/4m	3,000rpm	490(l) x 420(w) x 500(h)mm	35kg	74430020
YM 178F	3.8kW/5.2hp	3"	28m	60m ³ /h	296cc	120s/4m	3,000rpm	600(l) x 470(w) x 530(h)mm	52kg	74430030
YM 178F	4.4kW/6.0hp	2"	65m	30m ³ /h	296cc	60s/4m	3,600rpm	590(l) x 475(w) x 540(h)mm	57kg	74440020
YM 170F	6.5kW/9.0hp	4"	28m	80m ³ /h	96m ³ /hr	70s/4m	3,600rpm	640(l) x 525(w) x 570(h)mm	62kg	74430040

DIESEL DRIVEN TRANSFER PUMPS

- Self priming from 8 metres
- High volume water transfer
- Fast fill tanker applications
- Flood irrigation
- Construction site dewatering
- Viton seals fitted
- Adjustable for pumping diesel fuels and some chemicals



74440050

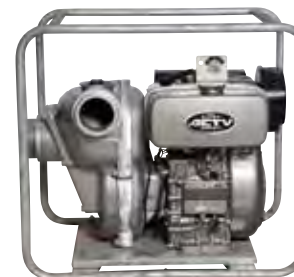

74440060

Engine	Start	Motor	Max. Head	Max. Flow	Inlet/Outlet	Bishops Code
Yanmar	Recoil	4.8hp	28m	700L/min	2"	74440050
Yanmar	Recoil	4.8hp	30m	1,050L/min	3"	74440055
Yanmar	Electric	4.8hp	30m	1,050L/min	3"	74440056
Kubota	Electric	9.0hp	30m	1,600L/min	4"	74440060

6" TRASH PUMP

- This high performance pump is the ideal choice for moving large volumes of water
- Discharge elbow rotates 360° to accommodate various discharge angles
- Automatic engine shutdown protects engine from damage due to low oil pressure or high cylinder temperature
- Lombardini 11LD625-3 diesel 3 cylinder air-cooled, 4-cycle engine
- Displacement: 1,870cm³
- Max. speed: 2,500rpm
- Max. rated power: 24kW
- Fuel consumption: 4.5L/hr
- Fuel tank capacity: 114L
- Discharge head: 30.5m
- Pressure: 3 bar
- Flow rate: 4,933L/min
- Suction lift height: 7.5m
- Max. solids diameter: 50mm
- Weight: 850kg



Item Code	Bishops Code
PT 6LS	76550220

3" TRASH PUMP

- Hatz diesel air-cooled, single cylinder, 4-cycle engine
- Max. discharge head: 29mm
- Max. discharge: 1,515L/min
- Max. suction lift: 7.6m
- Solid size capacity: 38mm
- Displacement: 347cm³
- 5kW (6.8hp)
- Max. speed: 3,500rpm
- Fuel tank capacity: 5L
- Fuel consumption: 1.7L/hr
- Weight: 73kg



Item Code	Bishops Code
PT 3H	76550200

CYCLONE PORTABLE ELECTRIC AIR COMPRESSOR

- 12V DC, 23amp
- 150psi
- Flow rate: 37.5L/min
- Complete with coil hose and gauge with sports adaptor kit
- Handy travel bag included



Item Code	Bishops Code
AIR150	73010105

HOW TO CHOOSE A COMPRESSOR

Electric or Petrol?

Electrical compressors are cheaper to operate and require less maintenance, the only negative being it can only be used when in the vicinity of an electrical power source. Although more expensive to run, petrol compressors are more flexible and able to be run without an electricity source. As petrol compressors emit fumes while in operation, you should only use them outdoors or in well ventilated areas.



Mobile or Fixed?

Does your compressor need to be portable to take to different jobs, or will it be fixed in a workshop? Mobile compressors are lighter in weight and are usually mounted on wheels for easy transport. To be so light weight the compressor compromises on power, fixed compressors typically have more 'grunt'.



Free Air Delivery (FAD)

Free air delivery or FAD is the quantity of compressed air back to the inlet conditions of the compressor, essentially how fast it can supply air. Measured in litres per minute (L/min), if the air tool you are using uses air faster than the compressor can supply it you will have to stop work, which is inefficient. The higher FAD, the more tools you will be able to connect, and the more efficient you will be.

Maximum Pressure

Air compressors typically sit between 120–150psi, with the exception of high pressure varieties which can be rated up to 175psi. This is substantial for use with most air tools. A higher psi allows a compressor with a smaller tank to perform like a compressor with a bigger tank.



Tank Size

The larger the tank size the more air you will be able to use before the pressure drops. This will give you more time before you need to stop work and let the tank refill. If you are using tools in short bursts, a small tank will do the job. If you use your tools for a long period of time, opt for a larger tank.

If you need any help selecting your next compressor, just ask Bishops.





ELECTRIC AIR COMPRESSORS

WORKSHOP, MACHINERY & CONSTRUCTION EQUIPMENT

ELECTRIC AIR COMPRESSORS



Puma 240 Volt

- Puma cast iron V-twin or W-triple compressor pump
- V-belt driven, low-revving pump speed for durability
- Teco™ copper-wound, steel frame single-phase motor
- Filter-regulator and Nitto-style air outlet coupling
- Puncture proof solid rubber tyres on steel wheels

Puma 415 Volt

- Puma cast iron V-twin or W-triple compressor pump
- V-belt driven, low-revving pump speed for durability
- Teco™ copper-wound, cast iron frame 3-phase motor
- Direct-on-line (≤ 7.5 kW) or star-delta (11 kW) motor starter
- Oversized air tank with anti-block condensate drain valve

Airmac 415 Volt High Pressure

- Fusheng™ cast iron, two-stage compressor pump
- V-belt driven, low-revving pump speed for durability
- Teco™ copper-wound, cast iron frame 3-phase motor
- Condor™ direct-on-line pressure switch with overload relay
- Oversized air tank with anti-block condensate drain valve



Model	Displacement	Pressure	Motor	Power	Phase	Tank	Mounting	Noise	Dimensions (L x W x H)	Weight	Bishops Code
Puma P13	255L/min (9.0cfm)	1,000kPa (145psi)	1.65kW (2.2hp)	240V	1	60L	2 Wheels	76dB(A)	1,110 x 450 x 730mm	83kg	*Puma P13
Puma P15	270L/min (9.5cfm)	900kPa (130psi)	1.65kW (2.2hp)	240V	1	60L	2 Wheels	72dB(A)	1,110 x 450 x 770mm	85kg	73010050
Puma P17	400L/min (14.1cfm)	1,000kPa (145psi)	2.2kW (3.0hp)	240V	1	60L	2 Wheels	78dB(A)	1,110 x 450 x 770mm	89kg	73010055
Puma P20	420L/min (14.8cfm)	900kPa (130psi)	2.4kW (3.2hp)	240V	1	75L	4 Wheels	75dB(A)	1,130 x 450 x 790mm	103kg	73010060
Puma P25	545L/min (19.3cfm)	900kPa (130psi)	3kW (4hp)	415V	3	125L	Pallet Feet	80dB(A)	1,400 x 510 x 900mm	178kg	*Puma P25
Puma P30	735L/min (26.0cfm)	900kPa (130psi)	4kW (5.5hp)	415V	3	140L	Pallet Feet	79dB(A)	1,550 x 510 x 960mm	205kg	*Puma P30
Puma P40	1,020L/min (36.0cfm)	900kPa (130psi)	5.5kW (7.5hp)	415V	3	215L	Pallet Feet	82dB(A)	1,510 x 610 x 1,100mm	316kg	73010092
Puma P55	1,415L/min (50.0cfm)	900kPa (130psi)	7.5kW (10hp)	415V	3	265L	Pallet Feet	81dB(A)	1,810 x 630 x 1,210mm	368kg	73010095
Puma P75	1,965L/min (69.4cfm)	900kPa (130psi)	11kW (15hp)	415V	3	330L	Pallet Feet	85dB(A)	1,850 x 650 x 1,220mm	477kg	73010098
Airmac HT20	320L/min (11.3cfm)	1,200kPa (175psi)	2.2kW (3.0hp)	415V	3	100L	Pallet Feet	80dB(A)	1,160 x 410 x 800mm	126kg	*Airmac HT20
Airmac B23	390L/min (13.8cfm)	1,200kPa (175psi)	3kW (4hp)	415V	3	125L	Pallet Feet	83dB(A)	1,480 x 470 x 950mm	172kg	*Airmac B23
Airmac B29	645L/min (22.8cfm)	1,200kPa (175psi)	4kW (5.5hp)	415V	3	150L	Pallet Feet	86dB(A)	1,490 x 520 x 1,060mm	232kg	*Airmac B29
Airmac B52	1,165L/min (41.2cfm)	1,200kPa (175psi)	7.5kW (10hp)	415V	3	300L	Pallet Feet	85dB(A)	1,850 x 660 x 1,170mm	407kg	*Airmac B52

* - SPECIAL ORDER: PLEASE QUOTE ITEM CODE UPON ORDERING THIS PRODUCT

ELECTRIC SCREW AIR COMPRESSORS



- Hanbell® precision technology rotary screw air-end
- V-belt driven, low air-end rotor speed design
- 7, 8 or 10 bar (102, 116 or 145 psi) outlet pressure
- Fixed-speed 'S' or variable-speed 'SV' models

GS-B & GSV-B Series

- Base-mounted, ultra-compact for limited access or space
- Connect to external air tank and air treatment equipment

GS & GSV Series

- Compressor set mounted on 450 litre air tank
- Connect to external air dryer and filters if required

CS & CSV Series

- Plug-and-play 4-in-1 compressed air station
- Compressor, 600L tank, dryer and pre/post-filters

LS & LSV Series

- Base-mounted for medium-to-large applications
- Connect to external air tank and air treatment equipment



Model	FAD @ 8 bar m ³ /min (cfm)	Motor kW (hp)	Noise	Dimensions (L x W x H)	Weight	Bishops Code	Model	FAD @ 8 bar m ³ /min (cfm)	Motor kW (hp)	Noise	Dimensions (L x W x H)	Weight	Bishops Code
GS4-B	0.60 (21.0)	4 (5.5)	62dB(A)	950 x 720 x 1,040mm	232kg	*GS4-B	CS11	1.78 (63.0)	11 (15)	70dB(A)	1,730 x 780 x 1,870mm	689kg	*CS11
GS6-B	0.82 (29.0)	5.5 (7.5)	67dB(A)	950 x 720 x 1,040mm	248kg	*GS6-B	CS15	2.45 (87)	15 (20)	72dB(A)	1,730 x 780 x 1,870mm	704kg	*CS15
GS8-B	1.10 (39.0)	7.5 (10)	68dB(A)	950 x 720 x 1,040mm	268kg	*GS8-B	CSV8	0.44-1.10 (16-39)	7.5 (10)	69dB(A)	1,730 x 780 x 1,780mm	584kg	*CSV8
GS11-B	1.78 (63.0)	11 (15)	70dB(A)	1,120 x 770 x 1,140mm	370kg	*GS11-B	CSV11	0.71-1.78 (25-63)	11 (15)	71dB(A)	1,730 x 780 x 1,870mm	710kg	*CSV11
GS15-B	2.45 (87)	15 (20)	72dB(A)	1,120 x 770 x 1,140mm	385kg	*GS15-B	CSV15	0.98-2.45 (35-87)	15 (20)	73dB(A)	1,730 x 780 x 1,870mm	734kg	*CSV15
GSV8-B	0.44-1.10 (16-39)	7.5 (10)	69dB(A)	950 x 720 x 1,040mm	283kg	*GSV8-B	LS18	3.08 (109)	18.5 (25)	70dB(A)	1,250 x 900 x 1,420mm	562kg	*LS18
GSV11-B	0.71-1.78 (25-63)	11 (15)	71dB(A)	1,120 x 770 x 1,140mm	391kg	*GSV11-B	LS22	3.58 (127)	22 (30)	71dB(A)	1,250 x 900 x 1,420mm	636kg	73050242
GSV15-B	0.98-2.45 (35-87)	15 (20)	73dB(A)	1,120 x 770 x 1,140mm	415kg	*GSV15-B	LS30	4.96 (175)	30 (40)	71dB(A)	1,460 x 1,020 x 1,690mm	900kg	*LS30
GS4	0.60 (21.0)	4 (5.5)	62dB(A)	1,360 x 780 x 1,830mm	408kg	*GS4	LS37	6.38 (225)	37 (50)	72dB(A)	1,460 x 1,020 x 1,690mm	916kg	73050272
GS6	0.82 (29.0)	5.5 (7.5)	67dB(A)	1,360 x 780 x 1,830mm	424kg	*GS6	LS45	7.18 (254)	45 (60)	73dB(A)	1,460 x 1,020 x 1,690mm	969kg	*LS45
GS8	1.10 (39.0)	7.5 (10)	68dB(A)	1,360 x 780 x 1,830mm	444kg	73050222	LS55	9.58 (338)	55 (75)	73dB(A)	1,790 x 1,250 x 1,900mm	1,419kg	*LS55
GS11	1.78 (63.0)	11 (15)	70dB(A)	1,360 x 780 x 1,900mm	546kg	*GS11	LS75	12.33 (435)	75 (100)	74dB(A)	1,790 x 1,250 x 1,900mm	1,579kg	*LS75
GS15	2.45 (87)	15 (20)	72dB(A)	1,360 x 780 x 1,900mm	561kg	*GS15	LSV18	1.08-3.08 (38-109)	18.5 (25)	71dB(A)	1,250 x 900 x 1,420mm	600kg	*LSV18
GSV8	0.44-1.10 (16-39)	7.5 (10)	69dB(A)	1,360 x 780 x 1,830mm	459kg	*GSV8	LSV22	1.25-3.58 (44-127)	22 (30)	71dB(A)	1,250 x 900 x 1,420mm	666kg	*LSV22
GSV11	0.71-1.78 (25-63)	11 (15)	71dB(A)	1,360 x 780 x 1,900mm	567kg	*GSV11	LSV30	1.74- 4.96 (61-175)	30 (40)	71dB(A)	1,460 x 1,020 x 1,690mm	953kg	*LSV30
GSV15	0.98-2.45 (35-87)	15 (20)	73dB(A)	1,360 x 780 x 1,900mm	591kg	*GSV15	LSV37	2.23-6.38 (79-225)	37 (50)	71dB(A)	1,460 x 1,020 x 1,690mm	970kg	*LSV37
CS4	0.60 (21.0)	4 (5.5)	62dB(A)	1,730 x 780 x 1,780mm	524kg	*CS4	LSV45	2.51-7.18 (89-254)	45 (60)	72dB(A)	1,460 x 1,020 x 1,690mm	1,025kg	*LSV45
CS6	0.82 (29.0)	5.5 (7.5)	67dB(A)	1,730 x 780 x 1,780mm	546kg	*CS6	LSV55	3.35-9.58 (118-338)	55 (75)	73dB(A)	1,790 x 1,250 x 1,900mm	1,485kg	*LSV55
CS8	1.10 (39.0)	7.5 (10)	68dB(A)	1,730 x 780 x 1,780mm	562kg	*CS8	LSV75	4.32-12.33 (152-435)	75 (100)	74dB(A)	1,790 x 1,250 x 1,900mm	1,626kg	*LSV75

* - SPECIAL ORDER: PLEASE QUOTE ITEM CODE UPON ORDERING THIS PRODUCT

SENATOR GSV8 PROFESSIONAL PACKAGE

- The smart value choice for energy saving compressed air systems
- Clean, dry compressed air is suitable for most pneumatic applications

Includes:

- Senator SE GSV8-8 variable speed compressor
- FR010A Refrigerant dryer
- Two stages of filtration

Specifications:

- Motor power: 7.5kW (10hp)
- Free air delivery: 0.44–1.10 m³/min (16–39 cfm)
- Working pressure: 10 bar (145psi)
- Tank volume: 450L
- Pre-filter: T10U, 1 Micron Coalescing
- Post filter: T10H, 0.01 Micron Coalescing



Item Code	Bishops Code
SE GSV8-8 PKG	73050220

SENATOR LS37 PROFESSIONAL PACKAGE

- Recommended for industrial applications with stable compressed air demand up to 12.33 m³/min
- Users can depend on these for clean, dry compressed air and low operating noise level

Includes:

- Senator SE LS37-10 compressor
- Vertical air receiver and accessory kit
- FR050A Refrigerant dryer
- Two stages of filtration

Specifications:

- Motor power: 37kW (50hp)
- Free air delivery: 6.38m³/min (225cfm)
- Working pressure: 10 bar (145psi)
- Vertical air receiver: 820L
- Pre-filter: T60U, 1 Micron Coalescing
- Post filter: T60H, 0.01 Micron Coalescing



Item Code	Bishops Code
SE LS37-10, 10 BAR	73050270

SENATOR LS22 PROFESSIONAL PACKAGE

- Recommended for industrial applications with stable compressed air demand up to 12.33 m³/min
- Users can depend on these for clean, dry compressed air and low operating noise level

Includes:

- Senator SE LS22-10 compressor
- Vertical air receiver and accessory kit
- FR030A Refrigerant dryer
- Two stages of filtration

Specifications:

- Motor power: 22kW (30hp)
- Free air delivery: 3.58m³/min (127cfm)
- Working pressure: 10 bar (145psi)
- Vertical air receiver: 530L
- Pre-filter: T40U, 1 Micron Coalescing
- Post filter: T40H, 0.01 Micron Coalescing



Item Code	Bishops Code
SE LS22-10, 10 BAR	73050240

GET MORE AT BISHOPS

AIR HOSE REELS

Page 476

AIR HOSE GUNS

Page 150



PETROL & DIESEL AIR COMPRESSORS

PORTABLE PETROL & DIESEL AIR COMPRESSORS



Puma Honda™ Petrol

- Puma long-stroke, hi-flow, cast iron compressor pump
- Auto-throttle minimises fuel use, noise and wear
- Electric key-start option (12V battery kit not included)
- Puncture proof tyres or pallet-foot vibration isolators



Airmac Honda™ Petrol High Pressure

- Fusheng™ cast iron, two-stage compressor pump
- Auto-throttle minimises fuel use, noise and wear
- Electric key-start option (12V battery kit not included)
- Puncture proof tyres or pallet-foot vibration isolators

Puma Yanmar™ Diesel

- Puma long-stroke, hi-flow, cast iron compressor pump
- Auto-throttle minimises fuel use, noise and wear
- Electric key-start option (12V battery kit not included)
- Mine Spec emergency stop fuel shutoff on 'ES' models



Airmac Yanmar™ Diesel High Pressure

- Fusheng™ cast iron, two-stage compressor pump
- Auto-throttle minimises fuel use, noise and wear
- Electric key-start option (12V battery kit not included)
- Mine Spec emergency stop fuel shutoff on 'ES' models

Model	Displacement	Max. Pressure	Engine Model	Starter	Tank	Mounting	Noise	Dimensions (L x W x H)	Weight	Bishops Code
HONDA PETROL										
Puma P18H	430L/min (15.2cfm)	1,000kPa (145psi)	GX200, 6.5 hp	Rope Pull	60L	2 Wheels	77dB(A)	1,120 x 450 x 770mm	90kg	73010090
Puma P22H	540L/min (19.1cfm)	1,000kPa (145psi)	GX200, 6.5 hp	Rope Pull	75L	4 Wheels	77dB(A)	1,130 x 450 x 800mm	112kg	*Puma P22H
Puma P22H ES	540L/min (19.1cfm)	1,000kPa (145psi)	GX200, 6.5 hp	Electric Start	75L	4 Wheels	77dB(A)	1,130 x 450 x 800mm	115kg	*Puma P22H ES
Puma P30H	805L/min (28.4cfm)	1,000kPa (145psi)	GX270, 9 hp	Rope Pull	125L	Pallet Feet	80dB(A)	1,410 x 450 x 970mm	189kg	*Puma P30H
Puma P30H ES	805L/min (28.4cfm)	1,000kPa (145psi)	GX270, 9 hp	Electric Start	125L	Pallet Feet	80dB(A)	1,410 x 450 x 970mm	192kg	*Puma P30H ES
Puma P55H ES	1,340L/min (47.3cfm)	1,000kPa (145psi)	GX390, 13 hp	Electric Start	140L	Pallet Feet	81dB(A)	1,560 x 480 x 1,080mm	257kg	*Puma P55H ES
Airmac HT20P-H	330L/min (11.7cfm)	1,200kPa (175psi)	GX200 6.5 hp	Rope Pull	70L	2 Wheels	77dB(A)	1,310 x 500 x 800mm	104kg	*Airmac HT20P-H
Airmac HT20P-H ES	330L/min (11.7cfm)	1,200kPa (175psi)	GX200 6.5 hp	Electric Start	70L	2 Wheels	77dB(A)	1,310 x 500 x 800mm	107kg	*Airmac HT20P-H ES
Airmac B24P	565L/min (20cfm)	1,200kPa (175psi)	GX270 9 hp	Rope Pull	100L	Pallet Feet	79dB(A)	1,150 x 480 x 970mm	154kg	*Airmac B24P
Airmac B24P ES	565L/min (20cfm)	1,200kPa (175psi)	GX270 9 hp	Electric Start	100L	Pallet Feet	79dB(A)	1,150 x 480 x 970mm	157kg	*Airmac B24P ES
Airmac B35P ES	945L/min (33.4cfm)	1,200kPa (175psi)	GX390 13 hp	Electric Start	120L	Pallet Feet	81dB(A)	1,150 x 530 x 1,070mm	214kg	*Airmac B35P ES
YANMAR DIESEL										
Puma P18Y	430L/min (15.2cfm)	1,000kPa (145psi)	L48, 4.7 hp	Rope Pull	60L	2 Wheels	83dB(A)	1,130 x 450 x 840mm	100kg	73060175
Puma P18Y ES	430L/min (15.2cfm)	1,000kPa (145psi)	L48, 4.7 hp	Electric Start	60L	2 Wheels	83dB(A)	1,130 x 450 x 840mm	105kg	*Puma P18Y ES
Puma P22Y	540L/min (19.1cfm)	1,000kPa (145psi)	L48, 4.7 hp	Rope Pull	75L	4 Wheels	83dB(A)	1,130 x 450 x 840mm	119kg	*Puma P22Y
Puma P22Y ES	540L/min (19.1cfm)	1,000kPa (145psi)	L48, 4.7 hp	Electric Start	75L	4 Wheels	83dB(A)	1,130 x 450 x 840mm	124kg	73060180
Puma P30Y ES	805L/min (28.4cfm)	1,000kPa (145psi)	L70, 6.7 hp	Electric Start	125L	Pallet Feet	87dB(A)	1,410 x 450 x 1,000mm	204kg	73060185
Puma P40Y ES	1,085L/min (38.3cfm)	1,000kPa (145psi)	L100, 10 hp	Electric Start	140L	Pallet Feet	89dB(A)	1,560 x 460 x 1,030mm	240kg	*Puma P40Y ES
Airmac HT20D	330L/min (11.7cfm)	1,200kPa (175psi)	L48, 4.7 hp	Rope Pull	70L	4 Wheels	82dB(A)	1,080 x 410 x 880mm	115kg	*Airmac HT20D
Airmac HT20D ES	330L/min (11.7cfm)	1,200kPa (175psi)	L48, 4.7 hp	Electric Start	70L	4 Wheels	82dB(A)	1,080 x 410 x 880mm	122kg	*Airmac HT20D ES
Airmac B24D ES	565L/min (20cfm)	1,200kPa (175psi)	L70, 6.7 hp	Electric Start	100L	Pallet Feet	84dB(A)	1,150 x 480 x 970mm	175kg	*Airmac B24D ES
Airmac B35D ES	945L/min (33.4cfm)	1,200kPa (175psi)	L100, 10 hp	Electric Start	120L	Pallet Feet	84dB(A)	1,150 x 530 x 1,070mm	239kg	73060190

* - SPECIAL ORDER: PLEASE QUOTE ITEM CODE UPON ORDERING THIS PRODUCT

PORTABLE DIESEL SCREW AIR COMPRESSORS

- High efficiency, low speed rotary screw air-end design
- 0 to 100% automatic compressed air flow rate control
- Performance matched Japanese diesel engine
- Lowest in class fuel consumption and noise level
- Automatic diesel fuel prime and air bleed system
- Integrated aftercooler option for cool dry air output
- Powder-coated steel chassis and body panels
- Key lockable cabinet doors, control panel and fuel filler
- Externally piped fluid drains for ease of maintenance
- Single lifting point above the C.O.G. for safe handling
- Made in Japan highest quality superior to all others



Model	Free Air Delivery	Rated/Max. Pressure	Aftercooler	Engine	Max. Fuel Use	Noise @ 7m	Dimensions (L x W x H)	Weight
FAC-18B	1.84m³/min (65cfm)	7bar (102psi)/9.2bar (133psi)	No	Kubota D722-K3A	3.9L/hr	67dB(A)	1,370 x 700 x 800mm	340kg
FAC-18BC	1.84m³/min (65cfm)	7bar (102psi)/9.2bar (133psi)	Yes	Kubota D722-K3A	3.9L/hr	67dB(A)	1,370 x 700 x 800mm	345kg
FAC-23B	2.3m³/min (80cfm)	7bar (102psi)/9.3bar (135psi)	No	Kubota D902-K3A	5.1L/hr	66dB(A)	1,500 x 770 x 865mm	435kg
FAC-23BC	2.3m³/min (80cfm)	7bar (102psi)/9.3bar (135psi)	Yes	Kubota D902-K3A	5.1L/hr	66dB(A)	1,500 x 770 x 865mm	440kg
FAC-28B	2.8m³/min (100cfm)	7bar (102psi)/9.0bar (130psi)	No	Kubota D1105-K3B	6.3L/hr	66dB(A)	1,580 x 770 x 900mm	500kg
FAC-28BC	2.8m³/min (100cfm)	7bar (102psi)/9.0bar (130psi)	Yes	Kubota D1105-K3B	6.3L/hr	66dB(A)	1,580 x 770 x 900mm	510kg
FAC-37B	3.7m³/min (130cfm)	6.9bar (100psi)/9.0bar (130psi)	No	Yanmar 3TNV88-BDHK	7.5L/hr	66dB(A)	1,700 x 890 x 1,080mm	720kg
FAC-37BC	3.7m³/min (130cfm)	6.9bar (100psi)/9.0bar (130psi)	Yes	Yanmar 3TNV88-BDHK	7.5L/hr	66dB(A)	1,700 x 890 x 1,080mm	730kg
FAC-52B	5.2m³/min (185cfm)	7bar (102psi)/9.0bar (130psi)	No	Yanmar 4TNV88-BDXHKS1	9.0L/hr	68dB(A)	1,970 x 950 x 1,080mm	855kg
FAC-52BC	5.2m³/min (185cfm)	7bar (102psi)/9.0bar (130psi)	Yes	Yanmar 4TNV88-BDXHKS1	9.0L/hr	68dB(A)	1,970 x 950 x 1,080mm	865kg
FAC-75B	7.5m³/min (265cfm)	6.9bar (100psi)/9.0bar (130psi)	No	Yanmar 4TNV98T-NHK	15.0L/hr	69dB(A)	2,050 x 1,200 x 1,250mm	1,290kg
FAC-75BC	7.5m³/min (265cfm)	6.9bar (100psi)/9.0bar (130psi)	Yes	Yanmar 4TNV98T-NHK	15.0L/hr	69dB(A)	2,050 x 1,200 x 1,250mm	1,320kg
FAC-110B	11.0m³/min (390cfm)	6.9bar (100psi)/8.5bar (123psi)	No	Isuzu CI-4JJ1X	20.0L/hr	70dB(A)	2,680 x 1,300 x 1,400mm	1,870kg
FAC-110BC	11.0m³/min (390cfm)	6.9bar (100psi)/8.5bar (123psi)	Yes	Isuzu CI-4JJ1X	20.0L/hr	70dB(A)	2,680 x 1,300 x 1,400mm	1,910kg

SPECIAL ORDER: PLEASE QUOTE ITEM CODE UPON ORDERING THIS PRODUCT

PEDESTAL FAN

- 3-blade solid steel fan
- Motor housing cast front, steel rear
- Closely meshed, powder coated wire guard (OH&S compliant)
- 3-speed motor to 1,350rpm
- 220-240V/50Hz 280W single phase
- Air flow: 300m³/min
- Height adjustable up to 1.8m
- Metal oscillating gears
- 90° oscillating angle or fixed
- Heavy duty metal cross base for ultimate stability



Item Code	Bishops Code
HW-26104	66512040

INDUSTRIAL FLOOR FAN

- 3-blade solid steel fan
- Motor housing cast front, steel rear
- Closely meshed, powder coated wire guard (OH&S compliant)
- 3-speed motor to 1,350rpm
- 220-240V/50Hz 280W single phase
- Air flow: 300m³/min



Item Code	Bishops Code
HW-18108	66512020

WALL MOUNTED FAN

- 3-blade solid steel fan
- Motor housing cast front, steel rear
- Closely meshed, powder coated wire guard (OH&S compliant)
- 3-speed motor to 1,350rpm
- 220-240V/50Hz 280W single phase
- Air flow: 300m³/min
- Adjustable wall mounting bracket
- Metal oscillating gears
- 90° oscillating angle or fixed



Item Code	Bishops Code
HW-26105	66512080

PORTABLE VENTILATOR SETS

- Compact in size, easy to operate
- Aluminium blades
- Suitable for use in manholes, underground tunnels, shipyards and other narrow places
- Includes fume extractor tube



76585200

Diameter	Flow Rate	Tube Length	Voltage	Bishops Code
12"	60-70m ³ /min	5m	240V	76585100
24"	70-90m ³ /min	10m	415V	76585200

FUME EXTRACTOR TUBE

- Suit portable ventilators (76585100 and 76585200) with 12" or 24" diameter ducting
- Length: 5m



Diameter	Bishops Code
12"	76585390
24"	76585395

GET MORE AT BISHOPS



VACUUM CLEANERS

Page 409



HIGH PRESSURE WASHERS

Page 410

90L LIGHT DUTY ELECTRIC PARTS WASHING TANK

- Spring loaded safety lid
- Flexible metal hose and nozzle
- Storage shelf under tank
- Tank dimensions: 730(l) x 500(w) x 230(h)mm



Item Code	Bishops Code
PW20G	30208020



METAL BENCH LATHES

MINI METAL BENCH LATHE – 250 x 500MM

- 3 phase
- 750W
- 240V
- 1.5hp
- Frequency: 50Hz
- 21mm spindle bore
- Spindle: MT3
- Spindle speed: 150–2,500rpm
- Distance between centres: 550mm
- Max. swing over bed: 250mm
- Centre height: 125mm
- Bed width: 135mm
- 1,015(l) x 500(w) x 500(h)mm (without stand)
- Stand included

Accessories

- 3 jaw chuck (125mm)
- Quadruple tool holder
- Chip sump
- Rear splash guard
- Lathe chuck protection
- 2 centres
- Tool kit with accessories and change gears



Turning Capacity	Bishops Code
Ø250 x 550mm	75550100

METAL BENCH LATHE – 360 x 1,000MM

- 1,100W at 3 phase
- 1,500W at 1 phase
- 3.0hp
- Spindle speed: 65–1,810rpm
- 5MT, 38mm dia. spindle
- 230V
- Frequency: 50Hz
- Distance between centres: 1,000mm
- Max. swing over bed: 360mm
- Centre height: 179mm
- Bed width: 206mm

Accessories:

- 3 jaw chuck (160mm)
- Change gears set
- 3MT dead centres
- 3MT and 5MT reduction sleeves
- Oil gun
- Tool box with tools
- Foot stands
- Splash guard and oil tray



Turning Capacity	Bishops Code
Ø360 x 1,000mm	75550200

METAL BENCH LATHE – 460 x 1,500MM

- Precision ground
- Fitted with safety torque limiting device
- 3 phase
- 4,000W/5.4hp at 1 phase
- Optional 5,500W/7.5hp at 3 phase
- 415V
- 50Hz
- Spindle speed: 25–2,000rpm
- MT6, D1-6/58mm spindle bore
- Capacity: 1,500mm
- Distance between centres: 1,500mm
- Centre height: 230mm
- Bed width: 300mm
- Max swing over bed: 460mm

Accessories:

- 3 and 4 jaw chucks
- Change gears set
- Chasing dial indicator
- Reduction sleeve
- Dead centres
- Tool box with tools
- Full length splash guard
- Brake and coolant system
- Steady rest and follow rest



Turning Capacity	Bishops Code
Ø460 x 1,500mm	75550460

METAL BENCH LATHE – 560 x 2,000MM

- 3 phase (415V, 50Hz)
- 7,500W
- 10hp
- 415V
- 50Hz
- Spindle speed: 25–1,600rpm
- MT7, 80mm spindle bore
- Distance between centres: 1,500mm
- Centre height: 1,160mm
- Max. swing over bed: 560mm
- Bed width: 350mm

Accessories:

- 3 jaw and 4 jaw chucks
- Quick change tool set
- Leadscrew cover
- Steady rest
- Dead centre



Turning Capacity	Bishops Code
Ø560 x 2,000mm	75550560

HYDRAULIC SHOP PRESSES



77060020

Capacity	Stroke	Work Range	Weight	Bishops Code
12t	175mm	0-920mm	63kg	77060012
20t	182mm	0-910mm	82kg	77060020
30t	160mm	0-840mm	150kg	77060030
50t	175mm	0-890mm	243kg	77060050
70t	250mm	226-1,042mm	425kg	77060070
100t	280mm	0-950mm	900kg	77060099

FORGED ANVIL

- Long stood for quality and craftsmanship
- Drop-forged and produced entirely from high grade steel for maximum durability
- The top face is ground and induction hardened to provide a lively surface to work on
- Horn: 5.5°
- Face: 8°
- Weight: 35kg/77.1lb



Item Code	Bishops Code
69622	64020583

3-IN-1 COMBINATION TUBE BENDER



- Accepts pipes with an outside diameter of 6, 8 and 10mm or ¼", 5/16" and 3/8"
- Bending capabilities of 0-180°



Item Code	Bishops Code
68111	64010030

LEVER TUBE BENDER

- Can bend up to 180° angle
- Suitable for light duty applications
- Easy to use and has clearly marked measurements
- 6mm capacity



Capacity	Bishops Code
6mm	64010210

HEAVY DUTY PIPE BENDER SET



- Fame and former system designed in conjunction with tube manufacturers
- Suitable for use in water services, gas services, handrails, gates, framework, galvanised, gas, water and steam pipes
- Comes complete with six super grade iron formers: 15, 20, 25, 32, 40 and 50mm
- 10t rating
- Robust construction
- Quick bending and release action
- Bends pipes with excellent results
- Simple set up and operation

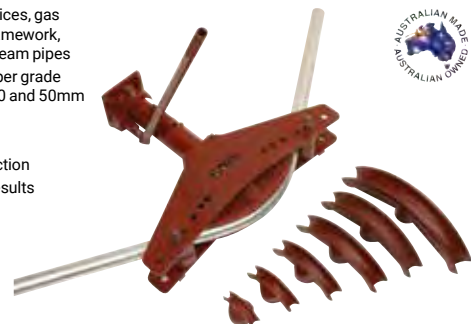

Item Code	Bishops Code
62168	61099115

HYDRAULIC PIPE BENDER

- Angle of bend: approx 90°
- Suitable for bending steel pipes
- 609(w) x 546(d) x 1,555(h)mm



77050050

Pipe OD Capacity	Ram	Stroke	Weight	Bishops Code
15-50mm	12t	232mm	38.5kg	77050050
15-75mm	15t	238mm	57.5kg	77050075

CURVAMATIC HYDRAULIC PIPE BENDER



- Designed to bend water, oil and gas steel pipes with maximum comfort and speed
- Provides optimum consistency and safety
- Anchored on a rotating tripod
- 2-VELO automatic valve system for fast preloading
- 360° rotating base



77050175

Item Code	Description	Pipe Size	Capacity	Weight	Bishops Code
60015	Curvomatic 2	6-50mm	10t	75kg	77050150
60016	Curvomatic 3	6-75mm	13t	110kg	77050175



PIPE & TUBE BENDERS & BENCH VICES

WORKSHOP, MACHINERY & CONSTRUCTION EQUIPMENT

TRUFORM BENDER

- Well established and proven bending technology and process developed with co-operation from pipe and tube designers/manufacturers to accommodate a huge range of their product
- Round and square pipes
- Thick and thin walled pipes
- Bends by drawing pipe through former and rollers
- The TruForm bender can bend pipes in many directions and through various degrees in the shortest possible length of pipe, making it suitable for virtually any application
- Robust construction
- Heavy gauge plate bender with hardened tool steel former/roller sets
- Will bend mild steel, stainless steel and aluminium pipes
- Used for steel fencing, street sign posts, gates, handrails, bench frames, cattle, sheep and horse stockyards, exhaust systems, bull bar construction, trampolines, commercial furniture, fire sprinkler systems, compressed air lines, playground equipment, boat trailers, ladder racks, roll bars and sheds
- Bend angle range: 0-180°
- Includes former sets: Round 15, 20, 25, 32, 40 and 50nb; Square 20, 25, 30, 35, 40 & 50mm

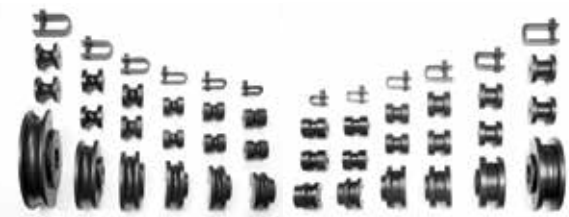

Item Code	Bishops Code
1000	61099130

MACHINE VICE

- For drilling, shaping and milling machines
- 360° swivel base
- Base can be secured to bench or stand
- Mechanical clamping
- Body made of high quality cast iron
- Max. jaw opening: 160mm
- Jaw width: 200mm
- Jaw height: 63mm
- Weight: 52kg
- Dimensions: 530(l) x 310(w) x 240(h)mm

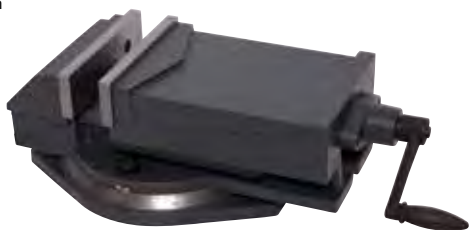

Item Code	Bishops Code
QH200	61598720

MACHINE (DRILL PRESS) VICES – SUPER GRADE

- Accurately machined slide
- Case hardened, replaceable "V" notched jaws
- ACME thread screw
- Corrosion resistant screw and forged handle
- Slots for hold down mounting bolts
- 25 year warranty



Item Code	Vice Jaw Width	Max. Jaw Opening	Jaw Height	Weight	Dimensions	Bishops Code
60219	75mm	60mm	27mm	4.6kg	170(l) x 135(w) x 64(h)mm	61598702
60220	100mm	120mm	37mm	11.6kg	240(l) x 190(w) x 82(h)mm	61598704
60221	125mm	250mm	45mm	21kg	410(l) x 220(w) x 89(h)mm	*60221

* – SPECIAL ORDER: PLEASE QUOTE ITEM CODE UPON ORDERING THIS PRODUCT

TYPES OF VICES

Make sure you have the right vice for your job. Make your next vice purchase an informed one by following the below guide.

Engineers Vices are designed to be bolted to the top of a workbench. The opening size is controlled by a threaded spindle and can be used for general purpose workshop jobs.



Drill Press Vices are made to be used in conjunction with a drill press machine. The vice holds the material being drilled in place. The bottom is free from obstruction to allow the drill piece to go completely through the material.



Pipe Vices are designed to hold pipes or tubes in place while cutting or threading. Traditionally used by plumbers, a chain secured by a screw is used to hold the pipe in place.



DRILL PRESS UNIGRIP VICE



- Manufactured from graded cast iron
- Precision ground base and vice bed for smooth lateral movement of the jaw
- Longitudinal and transversal prisms in the fixed jaw allow for firm gripping of round pieces both horizontally and vertically
- Special seat in jaws facilitates retaining of flat work pieces
- Convenient unigrip mechanism. Spindle moves inside the hollow hand grip allowing the vice to be used at a location away from the table edge, increasing the scope of application
- Jaw width: 120mm
- Max. jaw opening: 110mm

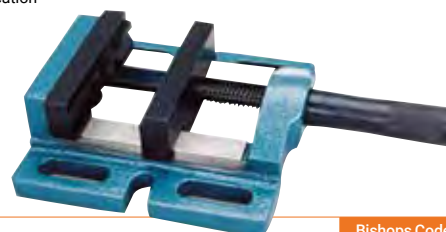

Item Code	Bishops Code
DPV/UG/125	61098860

DRILL PRESS UNIGRIP 3 WAY VICE

- Manufactured from graded cast iron
- Precision ground base and vice bed for smooth lateral movement of the jaw
- Longitudinal and transversal prisms in the fixed jaw allow for firm gripping of round pieces both horizontally and vertically special seat in jaws facilitates retaining of flat work pieces
- Convenient unigrip mechanism. Spindle moves inside the hollow hand grip allowing the vice to be used at a location away from the table edge, increasing the scope of application
- Also available with 3 mounting options via 2 additional precisely ground surfaces: end face and side face. This allows for drilling along all axes with a single setting of the job and holding of long workpieces which are cumbersome and difficult to manage in regular vices
- Jaw width: 100mm
- Max. jaw opening: 88mm



Item Code	Bishops Code
DPV/UG/3/100	61098850

ENGINEER'S STEEL BENCH VICES



- All steel construction, built to withstand the shocks of hammering, chipping and other tough applications
- Each vice has an integrated anvil for shaping and beating, an extra heavy-duty sliding jaw, large diameter steel screw and forged tommy bar
- Carbon steel jaws are hardened 50±5HRC to withstand tough use and are serrated for non-slip grip
- Safety stopper at the end of slide prevents it from fall during usage



Item Code	Jaw Width	Jaw Opening	Weight	Bishops Code
EBV/F/100	100mm	120mm	6.3kg	61098260
EBV/F/150	150mm	150mm	17.2kg	61098265
EBV/F/200	200mm	200mm	36kg	61098270

STANDARD ENGINEER'S VICES

- Original Dawn 100% Australian made and designed heavy duty vice
- High strength cast iron body, slide and nut
- Corrosive resistant ACME threaded screw
- "V" notched, case hardened, replaceable jaws
- Swarf deflector
- Forged steel handle
- 25 year warranty



Item Code	Vice Size Jaw Width	Max. Jaw Opening	Weight	Dimensions	Bishops Code
FIXED					
60151	75mm	85mm	5.4kg	250(l) x 120(w) x 113(h)mm	61598020
60153	100mm	115mm	16kg	367(l) x 163(w) x 177(h)mm	61598040
60156	150mm	175mm	33.4kg	497(l) x 195(w) x 215(h)mm	61598060
60157	200mm	225mm	57.8kg	650(l) x 237(w) x 275(h)mm	61598080
SWIVEL					
60163	100mm	115mm	18.8kg	367(l) x 215(w) x 205(h)mm	61598090
60165	125mm	145mm	27.5kg	445(l) x 238(w) x 225(h)mm	61598100
60166	150mm	175mm	39.9kg	497(l) x 265(w) x 252(h)mm	61598110
60167	200mm	225mm	74.6kg	650(l) x 335(w) x 336(h)mm	61598120

FABRICATED ENGINEER'S VICES

- Designed for all heavy duty work
- Manufactured from steel plate
- Corrosive resistant screw
- Replaceable case hardened jaws
- "V" notched jaw to hold round objects
- Forged steel handle
- Cast iron nut
- Precision machined bearing surface ensuring smooth operation
- 25 year warranty



Item Code	Vice Size Jaw Width	Max. Jaw Opening	Weight	Dimensions	Bishops Code
60205	100mm	115mm	10.5kg	342(l) x 150(w) x 138(h)mm	61598340
60206	125mm	145mm	18.6kg	433(l) x 180(w) x 181(h)mm	*60206
60207	150mm	175mm	22.6kg	495(l) x 200(w) x 192(h)mm	61598360
60208	200mm	200mm	37kg	616(l) x 200(w) x 228(h)mm	*60208

* - SPECIAL ORDER: PLEASE QUOTE ITEM CODE UPON ORDERING THIS PRODUCT

OFFSET ENGINEER'S VICES

- Australian designed 'Offset Advantage' which allows the user to work on long vertical sections with the full width of the jaws without obstruction from the main body of the vice
- High strength cast iron body, slide and nut
- Corrosive resistant ACME threaded screw
- "V" notched, case hardened replaceable jaws
- Swarf deflector
- Forged steel handle
- 25 year warranty



Item Code	Vice Size Jaw Width	Max. Jaw Opening	Weight	Dimensions	Bishops Code
60178	100mm	115mm	26.6kg	418(l) x 267(w) x 210(h)mm	61598140
60180	125mm	145mm	39.4kg	492(l) x 294(w) x 231(h)mm	61598150
60181	150mm	175mm	55.5kg	550(l) x 348(w) x 265(h)mm	*60181

* - SPECIAL ORDER: PLEASE QUOTE ITEM CODE UPON ORDERING THIS PRODUCT

FABRICATED OFFSET ENGINEER'S VICES

- Australian designed 'Offset Advantage' which allows the user to work on long vertical sections with the full width of the jaws without obstruction from the main body of the vice
- Designed for all heavy duty work
- Manufactured from steel plate
- Corrosive resistant screw
- Replaceable case hardened jaws
- "V" notched jaw to hold round objects
- Precision machined bearing surface ensuring smooth operation
- 25 year warranty
- Left hand offset versions also available



Item Code	Vice Size Jaw Width	Max. Jaw Opening	Weight	Dimensions	Bishops Code
60212	100mm	115mm	11.2kg	342(l) x 188(w) x 138(h)mm	61598440
60213	125mm	125mm	20.3kg	441(l) x 242(w) x 179(h)mm	*60213
60214	150mm	175mm	25kg	496(l) x 282(w) x 189(h)mm	61598460
60215	200mm	225mm	59.9kg	690(l) x 377(w) x 245(h)mm	*60215

* - SPECIAL ORDER: PLEASE QUOTE ITEM CODE UPON ORDERING THIS PRODUCT



BENCH & PIPE VICES & PIPE STANDS

OFFSET ENGINEERS' VICE – SUPER GRADE

- Australian designed 'Offset Advantage' which allows the user to work on long vertical sections with the full width of the jaws without obstruction from the main body of the vice
- Super Grade ductile iron
- Provides positive grip without springing and are ideal for heavy duty applications
- This world class vice which is unique to Dawn is simply the best vice a tradesman can own
- 25 year warranty



Item Code	Vice Size Jaw Width	Max. Jaw Opening	Weight	Dimensions	Bishops Code
60195	100mm	115mm	26.6kg	418(l) x 267(w) x 210(h)mm	*60195
60196	125mm	145mm	39.4kg	492(l) x 294(w) x 231(h)mm	*60196
60197	150mm	175mm	55.5kg	550(l) x 348(w) x 265(h)mm	61598160

* – SPECIAL ORDER: PLEASE QUOTE ITEM CODE UPON ORDERING THIS PRODUCT

WOODWORKERS' VICES

- Robust castings
- Generous jaw area
- Replaceable nut and screw
- Corrosion resistant screw and handle
- Square body for ease of fitting to bench
- Large diameter slide bars for smooth parallel operation
- Provision for attaching wooden liners to protect work pieces
- 25 year warranty



Item Code	Type	Vice Size Jaw Width	Max. Jaw Opening	Weight	Bishops Code
60241	Standard	175mm	225mm	7.8kg	61598604
60242	Standard	200mm	225mm	8.4kg	61598606
60243	Standard	225mm	300mm	12.6kg	61598608
60244	Standard	250mm	300mm	13kg	61598610
60247	Peg	175mm	225mm	8kg	*60247

* – SPECIAL ORDER: PLEASE QUOTE ITEM CODE UPON ORDERING THIS PRODUCT

MECHANICS VICE

- Manufactured from high quality grey iron castings
- Very strong with excellent shock absorbing capacity and immense strength under compression
- Machined to close tolerances and are designed for smooth operation and reliability
- Fully enclosed vice spindle keeps threads protected from contaminants and damage
- Long unbreakable malleable iron nut ensures maximum thread surface contact and constant alignment between the body and sliding jaw
- Jaws are hardened 45±5HRC
- Perfect alignment of main screw and nut reduces wear and gives long trouble-free service



Item Code	Jaw Width	Jaw Opening	Weight	Bishops Code
BV/F/100	100mm	125mm	9.2kg	61098210
BV/F/150	150mm	175mm	15.7kg	61098215
BV/F/200	200mm	200mm	32kg	61098220

CHAIN PIPE VICES

- Equipped with machine cut, heat treated jaws
- Can be rapidly tightened to provide a very powerful grip
- Chain type bottom screw
- Super grade ductile iron
- Popular plumbers tool
- Sturdy, compact design
- High tensile chain
- Extra lengths of chain can be added to accommodate larger diameter pipe
- 25 year warranty



Item Code	Type	Pipe Capacity OD	Weight	Bishops Code
60272	C2	65mm	1.8kg	*60272
60273	C4	120mm	4.5kg	64070520
60274	C6	175mm	7.9kg	64070540

* – SPECIAL ORDER: PLEASE QUOTE ITEM CODE UPON ORDERING THIS PRODUCT

HINGE TYPE PIPE VICE

- Capacity: ½"–2"



Item Code	Bishops Code
57619	61598545

TRI-STAND WITH CHAIN VICE

- Collapsible and stable frame, perfect transportable workbench
- Capacity: ½"–6"
- Holes and slots for attaching various tools
- Holes for bending of pipes with diameters ¾", ½" and ¾"
- Screw fixture for 1" pipe to enable overhead support
- The vice base overhangs front legs in order to allow the free working movement



Item Code	Bishops Code
612002	64070910

HEAVY DUTY VEE HEAD PIPE STAND

- Folding legs for easy storage
- Heavy duty ACME thread
- Pipe capacity: 300mm/12"
- Weight capacity: 900kg



Item Code	Bishops Code
	75595502

ROLLER HEAD PIPE STAND

- Adjustable height: 750–1,200mm
- V roller head
- Weight: 5.0kg



Item Code	Bishops Code
62154	75595500

BRICKLAYERS STRING LINE REEL

- 8 strand braided nylon
- 100m



Colour	Bishops Code
White	62522080
Green	62522082
Orange	62522084
Pink	62522086

SURVEY/FLAGGING TAPE

- Suitable for marking out in mining, construction, surveying, forestry and numerous other applications
- High quality and durable
- Hand tearable
- Ideal for use with survey pins for highly visible marks
- 25mm x 100m



Colour	Bishops Code	Colour	Bishops Code
Glo Pink	55060700	Green	55060740
Blue	55060710	Red	55060750
Yellow	55060720	Black	55060760
Orange	55060730	White	55060770

SOIL COMPACTION

Relative Desirability of Soils as Compacted Fill

Group Symbol		Gravel				Sand			
		GW	GP	GM	GC	SW	SP	SM	SC
Soil Type		Well graded gravels, gravel sand mixtures, little or no fines	Poorly graded gravels, gravel/sand mixtures, little or no fines	Silty gravels, poorly graded gravel, sand, and silt mixtures	Clay-like gravels, poorly graded gravel, sand, & clay mixtures	Well graded sands, gravelly sands, little or no fines	Poorly graded sands, gravelly sands, little or no fines	Silty sands, poorly graded sand/silt mixtures	Clay-like sands, poorly graded sand/clay mixtures
*	If Gravelly								
**	Erosion critical								
***	Volume change critical								
-	Not appropriate for this type of use								
Relative Desirability for Various Uses (10= Best; 1= Least Desirable)									
Rolled Earth Fill Dams	Homogeneous Embankment	-	-	9	10	-	-	7	8
	Core	-	-	7	10	-	-	5	9
	Shell	10	9	-	-	8*	7*	-	-
Canal Sections	Erosion Resistance	10	9	7	8	5	4*	3*	6
	Compacted Earth Lining	-	-	7	10	-	-	6**	9
Foundations	Seepage Important	-	-	10	9	-	-	8	7
	Seepage Not Important	10	8	7	5	9	6	4	3
Roadways	Fills - Frost Heave Not Possible	10	8	9	6	9	5	5	4
	Fills - Frost Heave	10	8	2	6	9	7	10	5
	Surfacing	3	-	6	10	7	-	6	2

Information provided as a guideline only.

Equipment Applications



Material	Plate Compactors	Reversible Plate Compactors	Tamping Rammers	Drum Vibratory Rollers
Granular Soils	1	2	-	2
Sand & Clay	2	1	2	1
Cohesive Clay	-	3	1	3
Asphalt	1	3	-	1

1= Provides optimum performance for most applications. 2= Provides acceptable performance for most applications. 3= Limited performance for most applications. Testing required.



PLATE COMPACTORS

PLATE COMPACTORS

- Conveniently placed handles makes them easy to reach
- Open design reduces dirt build-up and makes cleaning easier
- Air-cooled, 4-cycle, single cylinder

MS60-2

- Ideal for sand, gravel and mixer soils in narrow trenches and along foundations, walls and abutments
- Foldable handle for easy transportation and stock
- Radius base plate for easy access to corners
- Sealed belt cover to protect from sand and soil
- Heavy duty shock mounts reduce vibration to the upper engine and handle
- Built-in wheels for easy transportation

MS100-1 & MS100-2

- Powerful design for compaction of sand, gravel, grit and granular materials
- Vibration isolated reversible handle for easy operation and reduced operator fatigue
- Centrally mounted fully enclosed exiter for an even spread of compactive force over the whole base plate
- Heavy duty shock mounts reduce vibration to the upper engine and handle

MS90-2

- Malleable iron base provides longer life
- Easily remove water tank with built-in valve
- Rounded base plate for easy access to corners
- Located in the centre of the rising bar makes it easier to transport
- Timing is protected from sand and dirt
- Built-in wheels for easy transportation



WORKSHOP, MACHINERY & CONSTRUCTION EQUIPMENT

Item Code	Engine Type	Power	Operation Mass	Frequency	Centrifugal Force	Compaction Depth	Travel Speed	Efficiency	Plate Size	Dimensions	Bishops Code
MS60-2	Petrol 168F	4,000W, 4.5hp	62kg	5,600rpm	10.5kN	200mm	24m/min	450m ² /hr	360 x 500mm	1,080(l) x 400(w) x 800(h)mm	76510365
MS100-1	Diesel Kipor 170	3,100W, 4.2hp	104kg	7,000rpm	19.8kN	300mm	27m/min	770m ² /hr	460 x 610mm	1,100(l) x 460(w) x 660(h)mm	76510375
MS100-2	Petrol G200F	4,800W, 5.6hp	93kg	700rpm	19.8kN	300mm	27m/min	770m ² /hr	460 x 610mm	1,100(l) x 460(w) x 660(h)mm	76510380
MS90-2	Petrol Loncin MG200	4,800W, 6.5hp	91kg	5,500rpm	13kN	300mm	24m/min	600m ² /hr	530 x 500mm	1,100(l) x 830(w) x 500(h)mm	76510385

PLATE COMPACTORS

- Forward and reversible plate compactors
- For general compaction jobs
- High strength base plate with curved edges
- Open design with sturdy handles



Item Code	Type	Engine	Power	Plate Size	Centrifugal Force	Vibration Frequency	Travel Speed	Bishops Code
PC5021TL	Forward	Lombardini LD225	3.5kW, 4.8hp	570 x 500mm	21kN	5,400rpm	22m/min	76510420
PCR5030L	Reversible	Lombardini LD350	5.5kW, 7.5hp	690 x 500mm	30kN	5,400rpm	20m/min	76510460

WACKER NEUSON PLATE COMPACTORS

- Air-cooled, 4-cycle engine
- Base plate size: 460 x 610mm
- Overall dimensions: 1,100 x 460 x 600mm
- Max. forward travel: 28m/min
- Max. compacted area: 770m²/hr
- Max. gradability: 35%
- Vibration frequency: 116.6Hz (7,000rpm)
- Centrifugal force: 19.8kN
- Operating speed: 3,600rpm



Item Code	Engine Type	Displacement	Max. Rated Power	Fuel Consumption	Fuel Tank Capacity	Operating Weight	Bishops Code
VPH 70	Petrol Honda	163cm ³	4.1kW (5.5hp)	1.27L/hr	3.6L	77kg	76510120
VPY 70	Diesel Yanmar	211cm ³	3.5kW (4.7hp)	0.96L/hr	2.5L	90kg	76510122

REVERSIBLE PLATE COMPACTOR

- Conveniently placed handles makes them easy to reach
- Large heavy shock mounts reduce vibration to the handle and upper deck
- Wear-resistant base plates extend life and the open design reduces dirt build up
- Centrally located lifting bar allows easy transportation in and out of trenches
- Wrap around protection cage protects the plate from accidental jobsite damage
- Diesel Kipor 178 engine
- Power: 4,400W, 6hp
- Operation mass: 165kg
- Frequency: 4,000rpm
- Centrifugal force: 30.5kN
- Compaction depth: 500mm
- Travel speed: 15m/min
- Efficiency: 570m²/hr
- Plate size: 730 x 370mm
- Dimensions: 860(l) x 570(w) x 930(h)mm



Item Code	Bishops Code
MSH160-1	76510350

PETROL TAMPING RAMMER

- Driven by 4-stroke petrol engine designed specifically for rammer
- Heavy duty throttle control provides more reliable and longer service
- Double built-in filtration system provides cleaner air to engine for longer life and improved durability
- Heavy shock mount system to reduce hand-arm vibration and improve operator comfort
- Integrated fuel valve for easy starting
- Plastic oil tank offers longer life and rust-free
- Rammer shoe made of steel plate with wooden insert offers economical usage
- Special protective frame for engine
- Specially designed trolley kit for easy transportation
- High quality German made polyurethane bellow – more compacting force and offers a reliable lubricating system
- Air-cooled, 4-cycle, single cylinder
- Robin EH12-2D engine
- 3,000W, 4hp
- Operation mass: 75kg
- Percussion rate: 640–680/min
- Impact force: 14kN
- Jumping stroke: 40–80mm
- Fuel tank capacity: 3.0L
- Shoe size: 330(l) x 285(w)mm
- Dimensions: 430(l) x 760(w) x 1,020(h)mm



Item Code	Bishops Code
MR75R	76560130

WACKER NEUSON DIESEL TAMPING RAMMER

- Yanmar diesel air-cooled, single cylinder, 4-cycle engine
- Shoe size: 280 x 330mm
- Stroke: 75mm
- Percussion rate: 700bpm
- Travel speed: 13m/min
- Max. area capacity: 148m²/hr
- Displacement: 211cm³
- Max. rated power: 3.1kW @ 3,450rpm
- Power rating specification: SAE J1349, ISO 3046-1 IFN
- Fuel tank capacity: 4.2L
- Fuel consumption: 0.9L/hr
- Weight: 83kg



Item Code	Bishops Code
DS 70	76560120

PETROL TAMPING RAMMER

- Four-stroke vibratory rammer is perfectly balanced to deliver hard-hitting compaction as well as low noise and vibration to ensure operator comfort
- Protective top frame cover eliminates possible damage to the engine
- Convenient top front roller for easy loading
- German manufactured polyurethane ribbed bellow comes with a 3 year warranty
- Laminated wood and steel shoe absorbs and withstands vibration shock
- Bottom lifting handle
- Heavy shock mount system reduces hand-arm vibration and improves operator comfort
- Durable plastic oil tank is rust free and offers longer life
- Engine side-cover protects and guards recoil starter from particles
- Optional trolley wheel for easy transportation
- Robin EH12-2D engine
- 2,100W, 2.9hp
- Operation mass: 75kg
- Impact force: 13.8kN
- Jumping stroke: 40-80mm
- Fuel tank capacity: 2.8L
- Shoe size: 340(l) x 285(w)mm



Item Code	Bishops Code
PMR75R	76560140

SINGLE DRUM VIBRATORY ROLLER

- Lightweight and manoeuvrable
- Ideal for smaller maintenance jobs including work on footpaths, bridges and landscaping areas
- Fitted with a fully hydraulic drive system
- Safe to use due to reversing protection and deadman control
- Ergonomically designed handle and controls
- Honda GX160 engine
- 4,000W power
- Travel speed: 0–1.5km/h
- Water tank capacity: 15L



Item Code	Bishops Code
MSR58-4	76515110

DIESEL TAMPING RAMMER

- MR85D with outstanding Yanmar diesel engine L48 delivers much stronger impact force and ensures more convenient maintenance
- Diesel engine provides different fuel choice for jobsite
- Concise structure offers easier maintenance and accessibility
- Heavy shock mount system reduces hand-arm vibration and improve operator comfort
- Durable plastic oil tank with big capacity offers longer life and rust-free
- Laminated wood and steel shoe absorbs and withstand vibration shock
- Perfectly balanced while delivering ideal compaction with controlled jumping motions without affecting the impact force
- Diesel Yanmar L48 engine
- 3,500W, 4.8hp
- Operation mass: 85kg
- Impact force: 18kN
- Jumping stroke: 40–80mm
- Fuel tank capacity: 2.8L
- Shoe size: 340(l) x 285(w)mm



Item Code	Bishops Code
MR85D	76560132

DOUBLE DRUM VIBRATORY ROLLER

- Suited for more rugged construction site jobs
- Fitted with a fully hydraulic drive system
- Safe to use due to reversing protection and deadman control
- Ergonomically designed handle and controls
- Lombardini 15LD440 engine
- 8,100W power
- Travel speed: 0–3.6km/h
- Water tank capacity: 65L



Item Code	Bishops Code
MDR65-5	76515210



CONCRETE MIXERS, VIBRATOR POKERS & DRIVE UNITS

CONCRETE MIXER

- Suitable for small and occasional construction jobs
- Ideal for mixing mortar in small volumes
- Easy to transport
- Cast iron gear ring
- 178F hand start diesel engine



76505330

Power	Drum Speed	Filling Volume	Discharge Volume	Dimensions	Weight	Bishops Code
4-9hp	25-30rpm	260L/9.2cft	170L	1.90 x 1.17 x 1.42m	313kg	76505320
5.5-9hp	16-20rpm	350L/12.3cft	260L	1.90 x 1.17 x 1.65m	338kg	76505330
10hp	14rpm	560L/19.8cft	350L	2.766 x 2.140 x 3m	1,950kg	76505360

GET MORE AT BISHOPS



SHOVELS

Page 239

WACKER NEUSON PORTABLE VIBRATOR

- Honda GX 35 petrol air-cooled, 4-stroke, single cylinder engine
- Recoil start
- Head diameter: 45mm
- 1.2kW (1.6hp)
- Operating speed: up to 7,500rpm
- Max. rated power: 1.2kW @ 7,000rpm
- Piston displacement: 35.8cm³
- Power rating specification: SAE J1995
- Fuel tank capacity 0.65L
- Fuel consumption: 0.6L/hr
- Weight: 11.5kg



Item Code	Bishops Code
EZYVIBE4	76520210

CONCRETE VIBRATOR POKER

- Hard nose
- 6m flexible shaft
- Vibrator head length: 442mm
- Revolution of flexible shaft: 3,000-3,600rpm
- Low output speed helps extend the service life of the poker
- Is interchangeable between both electrical and petrol or diesel engine drive units



Item Code	Vibrator Amplitude	Approximate Weight	Head Dia.	Bishops Code
MV32	1mm	11kg	32mm	76590120
MV50	1.3mm	16kg	50mm	76590150
MV70	1.4mm	17kg	70mm	76590160

WACKER NEUSON CONCRETE VIBRATORS

- For use with Wacker Neuson drive motors
- Flexible shaft length: 6m
- *Compaction diameter is dependant on concrete consistency



Item Code	Head Dia.	Vibrations	Effective Compaction Dia.*	Weight	Bishops Code
FWP 40/6	40mm	12,000vpm	800mm	18kg	76590200
FWP 57/6	57mm	12,700vpm	1,000mm	23kg	76590210

WACKER NEUSON PETROL DRIVE UNIT

- Protective roll cage
- Dish base
- 4 stroke petrol engine
- 5.5/4.7hp
- Power: 4.1/3.5kW
- Speed: 2,800rpm
- Tank capacity: 3.6L
- Fuel consumption: 0.92L/h
- Dimensions: 460(l) x 460(w) x 530(h)mm



Item Code	Bishops Code
630242	76520145

DRIVE UNIT

- To suit concrete vibrator pokers
- Rubber mounts to reduce vibration
- 4 cycle, single cylinder
- Air cooled
- Recoil start
- 4.0kw



MVD-1



MVD-2

Item Code	Description	Power	Bishops Code
MVD-1	Loncin Diesel Engine	4.4hp	76520130
MVD-2	Loncin Petrol Engine	5.5hp	76520140

SUBMERSIBLE PUMP

- For use with Wacker Neuson diesel and petrol drive units
- Suitable for pumping from waste pits, dams, drainage trenches, footing, tanks, swimming pool excavations, and many other applications
- Handles solids up to 15mm
- Impeller can be adjusted to compensate for wear, without requiring special tools
- Rugged, low maintenance design
- Lightweight and self-priming
- Quick release drive coupling
- External protection spirals
- Heavy duty lifting eye
- Corrosion resistant cast iron body
- Multiple long-life seat
- Quality reliability
- 6m flexible shaft



Item Code	Bishops Code
SP55/6	76550180

SUBMERSIBLE PUMP

- Aluminium casting body
- Discharge diameter: 73mm/3"
- Max. lift: 18m
- Max. capacity: 1,300L/min
- 3,000–3,600rpm
- 5m hose
- 22kg



Item Code	Bishops Code
MSP-3	76550160

CONCRETING SCREED

- Clamp on style handle fixed with level bubble, which may be reversed to the working face for second use
- Fitted with end plugs and powder coated for easy clean-up



Item Code	Length	Bishops Code
SC18	1,800mm	63578100
SC36	3,500mm	63578120

ALUMINIUM BULLFLOAT

- Ideal for floating large areas of concrete
- Fitted with an aluminium blade and a double rib construction providing extra strength
- The float is properly balanced and long wearing
- The bracket assembly included is compatible with all standard threaded handles



Item Code	Description	Size	Bishops Code
AB9	Aluminium Bullfloat	900mm	63578160
AB15	Aluminium Bullfloat	1,500mm	63578162
H076	Telescopic Handle	2.4–4.8m	63578164

WOOD FLOATS

- Floats help in preparing a surface for trowelling or creating a rough finish
- Constructed from clear, seasoned wood
- Typically used for levelling out concrete before the final finishing stage



Item Code	Size	Bishops Code
H801	112(w) x 300(l)mm	63578220
H802	112(w) x 380(l)mm	63578222

MAGNESIUM FLOAT

- Floats help in preparing a surface for trowelling or creating a rough finish
- Cast from magnesium and recommended for use with air-entrained concrete
- The handle is attached with secure torque pad screws and its design provides more knuckle clearance for the user
- Perfectly balanced with a broken-in design
- Blade size: 84(w) x 510(l)mm



Item Code	Bishops Code
H252	63578262

STAINLESS STEEL VEE JOINTER

- Used to form 'dummy' joints in concrete paving
- Joint in the concrete reduces the thickness of the paving and if cracking occurs, the crack should be at the line of the joint
- Constructed from long wearing steel
- Specially designed handle with resilient comfort grips to help reduce fatigue
- Blade: 75(w) x 10(d)mm



Item Code	Bishops Code
H301S	63578275



CONCRETE FINISHING TOOLS, DEMOLITION BREAKER & BRICK SAW

WORKSHOP, MACHINERY & CONSTRUCTION EQUIPMENT

STAINLESS STEEL EDGERS

- Sturdy steel mounting
- Used to produce a radius at the edge of a concrete slab to help prevent the edge from chipping off
- Specially designed handle provides a soft feel which reduces fatigue and offers excellent durability



Item Code	Blade	Size	Bishops Code
H403S	10mm Radius	140(l) x 75(w) x 19(h)mm	63578265
H414S	45° Angle	125(l) x 25(bevel)mm	63578272

GET MORE AT BISHOPS



BUILDING FILM

Page 364

POINTING TROWEL

- Functional steel blade
- Non-slip handle
- Size: 150mm



Item Code	Bishops Code
3638001	63578218

TROWEL

- Shaped and tempered from the highest grade spring steel
- The ergonomic handle is comfortable, reduces fatigue and is very durable
- The mounting is made from an aluminium alloy making it lightweight but still very strong



Pointed



Square



Item Code	End Shape	Gauge	Size	Bishops Code
H101	Pointed	Light	120(w) x 365(l)mm	63578202
H109S	Pointed - Stainless Steel	Light	100(w) x 355(l)mm	63578208
H191S	Pointed - Stainless Steel	Light	115(w) x 405(l)mm	63578210
H102	Square	Light	120(w) x 280(l)mm	63578214
H162	Square	Heavy	120(w) x 280(l)mm	63578216

HELICOPTER TROWEL MACHINE

- Low maintenance and long-life design
- Ideal 36" diameter trowel for running pans, combination blade or finishing blades
- Over-built gearbox provides long service life
- Heavy weight design to assure a superior finish
- Height adjustable handle gives operator comfort and easy control
- Lifting tube as standard feature allows trowel to be transported on the job-site with only two people
- Centrifugal safety switch shuts the engine down in the event of the operator losing control of the unit
- Screw control ensures precise blade adjustment
- Air-cooled, 4-cycle, single cylinder
- Honda GX160 petrol engine
- 4,800W, 6.5hp
- Operation mass: 91kg
- Rotor diameter: 910mm
- Guard diameter: 940mm



Item Code	Bishops Code
MT36-2	76580180

DIESEL POWERED TROWEL MACHINE

- Professional machine for panning, floating and finishing
- Cast iron spider plates, lift levers and pressure plates
- Heavy duty gearbox
- Handle-mounted operating controls
- Padded handle bar and central lifting hook
- Yanmar GX690 4.7hp diesel engine
- Max. output: 3.5kW, 3,600rpm
- Trowel diameter: 915mm
- Max. blade speed: 125rpm
- Machine dimensions: 1,730 x 970 x 970mm
- Operating weight: 89kg



Item Code	Bishops Code
F03436D	76580190

PETROL BREAKER

- Wacker Neuson WM 80 gasoline air-cooled, single cylinder, 2-cycle engine
- Single stroke impact energy: 65J
- Percussion rate: 1,250bpm
- 4.6m/s² hand-arm vibrations
- Displacement: 80cm³
- Operating performance: 1.7kW (2.31hp)
- Max. speed: 4,100rpm
- Fuel tank capacity: 1.8L
- Fuel consumption: 1.1L/hr
- Weight: 25kg



Item Code	Bishops Code
BH 65	76540120

ELECTRIC BRICK SAWS

- Portable brick saw for pavers, bricks and tiles
- Powered by electric motor



76570120

Item Code	Power	Blade	Cut Length	Cut Depth	Bishops Code
MB14E	2.4kW, 3.2hp	350 x 25.4mm	420mm	125mm	76570120
PST61-1	2.2kW, 1.5hp	400 x 25.4mm	600mm	130mm	76570140

CONCRETE FLOOR SAW

- Whether cutting concrete or asphalt, the reinforced steel box frame design adds strength necessary to reduce vibrations while sawing
- Minimising vibrations enhances the performance of the blade and extends the life of the saw
- Super-rigid box frame ensures straight cuts while resisting warping and vibration - prolongs saw life and extends blade life
- Japanese shaft bearings for long service life
- Comfortable grip handles
- Easy crank for raising/lowering cutting depth
- Hinged front, lift-up blade guard is designed to provide easy blade replacement
- Easy remove, rustless poly water tank provides an optimum flow and volume of water to the blade
- 188F petrol engine
- 300-350mm blade size



Item Code	Bishops Code
MF20-2	76570250

CONCRETE FLOOR SAWS

- For cutting asphalt and concrete
- Left and right hand cutting
- Protective frame
- Reduced vibrations and comfort grip handle
- Adjustable cutting depth
- Saw position guide and water flow system
- Max. cutting depth: 140mm
- Blade size: 300-450mm
- Water tank capacity: 35L



Item Code	Engine	Power	Bishops Code
PMF18L	Lombardini LD440	7.5kW, 10.2hp	76570240
PMF18R	Robin EX40	10.3kW, 14hp	76570245

BAND SAW

- Saw arc tilting 45°
- Automatic switch-off after cutting
- 4 cutting speeds
- 415V, 1,100W
- Frequency: 50Hz
- Cutting capacity at 90°
Round: 180mm
Square: 180 x 300mm
- Cutting capacity at 45°
Round: 110mm
Square: 110 x 180mm
- Blade: 2,360(l) x 0.90(t)mm
- 8tpi
- Includes:**
- Quick lock vice stand
- Coolant system



Item Code	Bishops Code
SD200DG	75510200

LIGHTING TOWER

- Ideal for construction projects, road works and events
- Compact design
- Trailer mountable
- Powered by Kubota Z482-E38-BG engine
- Auto mast lowering system and off-balance protection
- Features 4 x 500W LED lights
- 48V/DC
- Lumens: 213,000



Item Code	Bishops Code
MS2000	74090600

SG 71 MANUAL BACKPACK SPRAYER



- Backpack sprayer for occasional and professional use
- Increased user comfort through pump lever mounted on the right or left and length adjustment
- High quality straps and moulded back panel for greater user comfort
- Ergonomic shutoff valve with pressure gauge
- Tank capacity: 18L
- Weight: 5kg



Item Code	Bishops Code
4255 019 4970	75092086

SR 450 PROFESSIONAL MISTBLOWER



- Designed for the harshest of professional applications
- Powerful and versatile, their strengths are most impressively demonstrated on difficult terrain or large areas of land
- Ergonomic and lightweight, easy to use with just one hand
- Accurately delivers liquids, granules or seeds over a wide area
- Optimum conditions for strong growth and productive soil
- Multi-function handle puts all the engine controls at your fingertips, allowing easy and safe operation
- Anti-vibration system
- Comfortable backpack carrying system adapted to suit the user's shoulders
- ElastoStart reduces the shock caused by the compression of the engine during starting
- Displacement: 63.3cc
- Max. air throughput: 1.300m³/h
- Weight (without fuel): 12.8kg



Item Code	Bishops Code
4244 011 2602	75092088



09 GENERAL INDUSTRIAL PRODUCTS

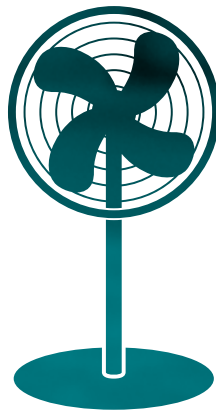

TAPES

Masking & Electrical Tapes	347
Cloth, Duct & Gaffer Tapes	347
Aluminium Foil Tapes.....	347
Sealing, Double Sided & Foam Tapes.....	348
Filament & Packaging Tapes.....	349

PACKAGING & MAIL ROOM

Poly & Steel Strapping.....	349
Strapping Buckles & Seals.....	350
Strapping Dispensers & Tools.....	350
Pallet Wrapping Film & Dispensers	351
Packing Paper & Bubble Wrap	352
Packing Scales.....	352
Scissors & Magnifying Glass	352

MARKING & PAINTING SUPPLIES

Carpenters Pencil	352
Paint Markers	353
Marking Chalk & Holders	354
Ink Markers.....	354
Marking Paint & Applicators.....	354
Paint Primers.....	355
Anti-Corrosion & Anti-Slip Paints	355-356
Paint Brushes & Rollers.....	356-357
Spray Paint Guns & Applicators.....	358
Paint Mixers & Scrapers.....	358

LADDERS & HEIGHT ACCESSORIES

Safety Steps & Step Ladders.....	359
Double Sided Ladders.....	360
Extension & Platform Ladders.....	361
Scaffolding & Accessories	362

GENERAL CONSTRUCTION & HARDWARE

Tarpaulins & Fittings.....	363
Extension & Compression Springs.....	363
Builders Film & Grout	364
Bronze & Nylon Rods.....	364
Wire & Fence Equipment.....	364
Padlocks & Security.....	365-366

ELECTRICAL & LIGHTING

Cable Ties	366-367
Extensions Leads & Reels	368
Plugs, Outlets & Power Boards	368-369
Circuit & Cable Testers.....	369
Voltage Testers	370
Multimeters & Clamp Meters	370-372
Head Lamps	373
Pocket & Hand Torches.....	373-374
Inspection & Work Lights.....	375-376
Floodlights.....	376
Automotive Lights, Reflectors & Fittings.....	377-379
Reversing Alarms & Trailer Cables	380
Electrical Wiring & Cable Accessories	381

BATTERIES

Alkaline & Household Batteries	382
Battery Chargers.....	382-383
Jump Starters, Jumper Leads & Load Testers	383-384
Terminals & Accessories	384
Battery Maintenance.....	384-385

AUTOMOTIVE WORKSHOP

Automotive Repair & Maintenance.....	385-386
Jack Stands.....	387
Bottle & Floor Jacks	387-388
Farm Style & Transmission Jacks	388
Engine Cranes & Stands	388
Car Hoists & Ramps	389
Tyre Changers & Wheel Balancer.....	389
Mechanics Creepers	390
Wheel Chocks & Recovery Track	390
Tyre Inflators & Gauges.....	391
Tyre Levers & Wrenches.....	392
Waste Oil Management.....	393
Oil & Fuel Cans & Containers.....	393-394
Funnels.....	395

DIFFERENT TAPES & THEIR USES

Don't get caught in a sticky situation, make sure you are using the right tape for the job.

Types Of Adhesives Used For Tapes

- Acrylic adhesives provide excellent environmental resistance and provide a fast setting time
- Epoxy resins exhibit high strength and low shrinkage during curing and are known for their resistance to chemical and environmental damage
- Rubber-based adhesives provide highly flexible bonds and are usually based on butadiene-styrene, butyl, polyisobutylene or nitrile compounds
- Silicone adhesives and sealants have a high degree of flexibility and are resistant to very high temperatures
- Polyurethane and isocyanate adhesives provide more flexibility, impact, resistance, and durability



Masking Tapes

Masking tapes are used generally and in painting to mask off portions. Masking tapes are made of thin, tearable paper. Look for how many days it can be left in place and still remove cleanly.



Duct Tape

Is tough due to a composite make-up of woven cotton cloth backed with polyethylene, then coated with a high-tack adhesive. Duct tape conforms to almost anything and forms a waterproof seal which makes it perfect for almost any task.



Gaffer Tape

Originally developed for the entertainment industry, its flexibility is ideal for holding down cables and marking positions, and the matt finish doesn't create any glare by reflecting lighting. It has a very strong hold but thanks to its residue-free adhesive, you can remove it without leaving any stickiness behind.



Metal Foil Tapes

Aluminium-reinforced and lead backings resist flames, temperature extremes and high humidity. Metal tapes are usually designed for taping joints and seams against moisture or vapour. Aluminium foil is laminated to paper or plastic films to provide more strength.



Floor & Lane Marking Tape

This durable self-adhesive PVC tape is for marking floors and is often used as safety warning against floor slips. Ideal for loading docks, shipping areas and in warehouses or in other areas where accidents may occur.

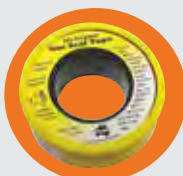

Thread Seal Tapes

Used for sealing threading, the tape lubricates allowing for a deeper seating of the threads, and it helps prevent the threads from seizing when being unscrewed. Thread seal tape also works as a deformable filler and thread lubricant, helping to seal the joint without hardening or making it more difficult to tighten.



Silicone Tape

Made of a single self-fusing compound that bonds to itself, no adhesives required. It provides waterproof seals and electrical insulation in wrap-style applications. Simply stretch and wrap it (slightly overlapping) to create a seal, and after a curing period, the silicone will create an unbreakable bond.



Hook and Loop Tape

Consists of two fabric strips with adhesive backing. One tape has tiny hooks on the front side, the other has even smaller loops. When the two front sides are pressed together, the hooks attach to the loops, binding the two pieces.



Packaging Tape

A simple, medium-strength tape designed for sealing packages. It is widely used in package delivery and mail services, as well as general sealing and enclosing. Brown and translucent tapes are most common, but other designs with messages (fragile, secured etc.) or patterns are manufactured.



Cross Weave Filament Tapes

When bundling demands extra strength of a durable tape, a cross weave filament tape is recommended. It is ideal for heavy duty enclosures in export packaging and performs well under normal temperature.

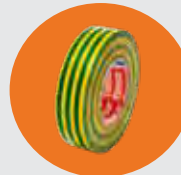

Electrical Tape

Made of slightly stretchy PVC vinyl, backed with a pressure sensitive rubber-type adhesive. It has good insulation properties and is perfect for protecting wire splices and providing extra insulation for electrical cords. It is also available in a variety of other colours that can be used for colour-coding.



Foam Tape

Adhesive-coated foam backing tape contains an adhesive that is protected by a foam liner. Foam tape is often used for sealing, weather-stripping, and mounting and comes in various thicknesses and widths.

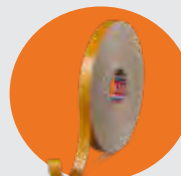

Double-Sided Tape

Used when needing front-and-back sticking power. Simply cut a length of tape, press the exposed adhesive onto the item you're working with, peel off the liner, and press the second side against the surface you want it to stick to. Available in a variety of adhesive strengths.

MASKING TAPE

- Flexible crepe paper tape with high tack rubber adhesive
- Provides excellent adhesion
- Suitable for non-critical masking
- Temperature resistant to 50°C
- Cream coloured
- Tensile strength: 85N/25mm
- Thickness: 130µm



Item Code	Size	Bishops Code
8801	12mm x 50m	66040110
50101 CM 50m x 18mm	18mm x 50m	66040120
50101 CM 50m x 24mm	24mm x 50m	66040130
50101 CM 50m x 36mm	36mm x 50m	66040140
50101 CM 50m x 48mm	48mm x 50m	66040150

PVC ELECTRICAL INSULATION TAPE

- Plasticised PVC backing
- Roll size: 18mm x 20m



Colour	Bishops Code	Colour	Bishops Code
Black	66540010	White	66540050
Blue	66540020	Yellow	66540060
Green	66540030	Yellow & Green Stripe	66540070
Red	66540040	Mixed Pack x 10 Rolls	66540090

DUCT TAPE

- General purpose joining tape
- Suitable for a range of automotive, construction and HVAC applications
- Tensile strength: 54N/25mm
- Thickness: 120µm
- Silver
- Also available in black



Size	Bishops Code
48mm x 30m	66040450

GAFFER TAPE

- Heavy duty cloth tape with rubber adhesive
- Sandblasting masking
- High tensile strength
- Suitable for fixing wires and cables on stage
- Temperature resistant to 93°C
- Black
- Tensile strength: 197N/25mm
- Thickness: 330µm
- 48mm x 40m



Item Code	Bishops Code
58663-00000-00	65230060

CLOTH TAPE

- Standard grade polyethylene coated tape
- 55 mesh woven PET/rayon fabric backing with a natural rubber adhesive
- Suitable for bundling, wrapping, colour coding and repairing
- Waterproof
- Hand tearable
- Tensile strength: 52N/cm
- Thickness: 260µm
- All colours available in 24mm, 36mm, 48mm, 72mm and 96mm widths
- Also available in beige

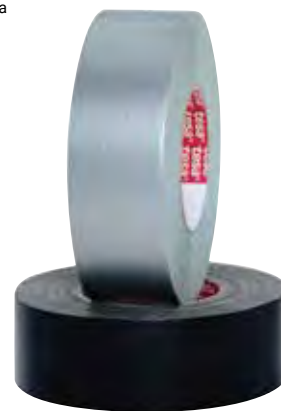

24MM X 25M			48MM X 25M		
Item Code	Colour	Bishops Code	Item Code	Colour	Bishops Code
04688-00125-00	Black	65230020	04688-00087-00	Black	65230033
04688-00160-00	Red	65230021	04688-00162-00	Red	65230027
04688-00141-00	Silver	65230022	04688-00088-00	Silver	65230028
04688-00147-00	Yellow	65230023	04688-00149-00	Yellow	65230029
04688-00135-00	Green	65230025	04688-00090-00	Blue	65230030
04688-00167-00	White	65230026	04688-00137-00	Green	65230031
-	-	-	04688-00169-00	White	65230032

ALUMINIUM FOIL TAPE

- High strength, release-coated and self-wound aluminium foil
- Designed with an aggressive acrylic based adhesive
- Provides an excellent vapour seal and conforms well around corners and irregular shaped surfaces
- Adhesive performs well under a wide range of temperatures
- Hand tearable for easy application
- Min. temp: -32°C
- Max. continuous temp: 127°C



Size	Bishops Code
25mm x 50m	66040540

ALUMINIUM FOIL TAPE

- Aluminium foil reinforced with PE mesh
- Aggressive acrylic based adhesive
- Provides an excellent vapour seal and conforms well around corners and irregular shaped surfaces
- Adhesive performs well under a wide range of temperatures
- Hand tearable for easy application
- Temperature range: -32°C to 127°C

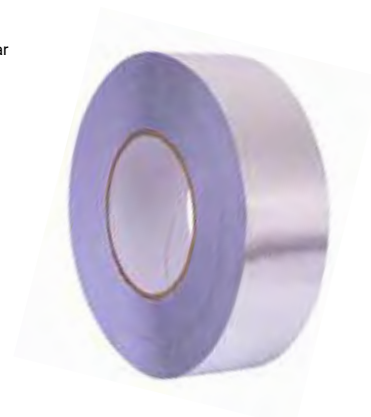

Size	Bishops Code
48mm x 55m	66040550



PTFE THREAD SEALING TAPES

- Temperature range: -268°C to 260°C

Pink

- Suitable for plumbers and pipe fitters – all threaded connections involving air, water, sewage and chemical
- Max. pressure rating: 10,000psi (68.95MPa)

Gold

- Clean, easily applied, non-toxic
- Highly inert, chemically resistant to almost all known chemicals, gaseous or liquid

Eureka

- Clean, easily applied, economical, non-toxic, hypoallergenic



Item Code	Description	Size	Thickness	Bishops Code
T4HG005	Gold	12mm x 13.7m	0.1mm	32426030
T4HG008	Gold	19mm x 13.7m	0.1mm	32426040
T4HG011	Gold	25mm x 13.7m	0.1mm	32426060
T4HP2022	Pink	12mm x 13.5m	0.1mm	32426035
T3EU003	Eureka	12mm x 10m	0.076mm	32426010
T3EU021	Eureka	25mm x 12m	0.076mm	32426050

XTREME REPAIR SILICONE TAPE

- Self-amalgamating silicone adhesive
- Excellent resistance against most oils, acids, solvents, water and UV radiation
- Used for high pressure leaks up to a maximum of 12bar (174psi)
- Adheres to most surfaces including dirty and oily surfaces
- Instant sealing even under water
- For temporary and permanent applications
- Clean removal from most materials without adhesive residues
- Black
- Thickness: 750um
- Tensile strength: 45N/cm
- Temperature rating: -65°C to 260°C



Item Code	Size	Bishops Code
04600-00006-00	25mm x 10m	66040560
04600-00005-00	50mm x 10m	66040565

DOUBLE SIDED PVC TAPE

- Made with a PVC film backing and a tacky acrylic adhesive
- Provides high performance bonding on rough or dusty surfaces
- Suitable for long term applications
- Tensile strength: 38N/cm
- Thickness: 225µm



Size	Bishops Code
12mm x 33m	65230010
24mm x 33m	65230015

SINGLE SIDED FOAM TAPE

- Closed cell foam tape
- Made from tough, weather resistant, high temperature EPDM foam
- Suitable for sealing in outdoor conditions
- Black
- Thickness: 6.4mm
- Available in a range of thicknesses and widths



Size	Bishops Code
24mm x 15m	65230070

WHAT'S THE DIFFERENCE BETWEEN SPONGE & FOAM TAPE?

Sponge Tape

Sponge tape contains sponge rubber in either open-cell or closed cell form.

Foam Tape

Foam tape is made from foam rubber manufactured by blowing a gas into a liquid mixture to create a mass of small bubbles. Air bubbles in foam mean it will absorb some water and will not be water tight.



MATERIALS & THEIR USES

Foam and sponge tapes typically come in the following high strength, resilient materials.

Polyethylene Rubber-based adhesive, ideal for indoor use

Neoprene Long-lasting indoor/outdoor tape best for sealing and weather stripping applications

Polyurethane Conformable low-density foam which provides good insulation for interior/protected outdoor applications

PVC Best in applications where impact cushioning is necessary and long-term outdoor exposure is expected

Nitrile Ideal for use in machinery and heavy appliances due to its powerful vibration dampening and impact cushioning

EPDM Available with or without adhesive, possesses superior durability and resistant to heat, chemicals and weather

OPEN VS CLOSED CELL TAPES

Open cell foam and sponge tapes allow particles such as air and water to pass through from one cell to another. Open cell tapes are used where separation is needed to prevent vibrations or provide a thermal barrier but some airflow is still needed, for instance in electronic components.

Closed cell tapes have a closed cell structure and are used where separation is needed to prevent vibrations or provide a thermal barrier. They can be used as gasketing materials where the application requires there to be no passing of air, moisture or particles.

CROSS WEAVE FILAMENT TAPE

- Premium quality tape
- Synthetic rubber adhesive
- High level of adhesion
- Tear resistant
- Ideally suited to bundling and strapping of heavy goods, securing pallets and reinforcing shipping cartons that are exposed to shocks during transport
- Tensile strength: 250N/cm



Size	Bishops Code
50mm x 50m	65230040

PREMIUM PACKAGING TAPE

- General purpose carbon sealing tape
- Acrylic adhesive
- Suitable for bundling and parcel sealing
- Can be used on paper, cardboard and stretch film
- Water resistant
- 30µm backing
- Roll size: 48mm x 75m

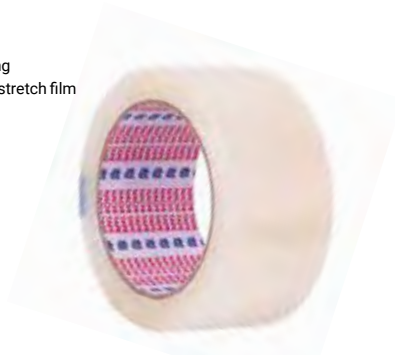

Colour	Bishops Code
Brown	66040250
Clear	66040270

POLY STRAPPING

- Flexible poly strapping
- Easy to use
- Comes in convenient dispenser box
- Length: 1,000m
- Blue



Item Code	Width	Bishops Code
35011203	12mm	66030020
35011503	15mm	66030040

STEEL STRAPPING

- High tensile steel strapping
- Safe to use with rounded edges
- Easy to handle when used with a steel strap dispenser
- 0.5mm thickness



Width	Length	Bishops Code
16mm	200m	66030240
19mm	210m	66030280

TYPES OF STRAPPING & WRAPPING

Ensure your packages reach their destination safe and intact by picking the right strapping. Each package and securing device is different. This guide is designed help you decide what securing device is best for your needs.

STRAPPING

Polypropylene (PET) – Light duty strapping option. It has low break strength and stretches under pressure, but does not return to its original size. Good for use in automatic strapping tools.

Polyester – The most common replacement for steel strapping. It has high break strength, but also stretches under pressure, reducing the chance of snapping. It works well for heavy 'settling' loads.

Fibre – Manufactured from high tensile polyester, engineered to have the strength of steel, but with increased flexibility and wear. The structure of the strapping forms a cross pattern, with reinforcing fibres helping to maintain tension.

Lashing – Made from strong, flexible polyester fibres. The lashing ropes are connected to buckles and hooks which can be tightened and loosened for multiple uses. Lashing is suitable for securing large, obscure loads for transport.

Steel – Strong and hard wearing. High break strength sets it apart from other strapping materials, providing reliability in heavy duty applications. However, steel is rigid and inflexible. When bent, twisted or deformed it can be prone to snapping!

WRAPPING

Film – Stretch wrap film is stretched and wrapped around items to keep them protected and in place. The tension caused by the stretch wrap stops the products from moving during transit.

Bags – Bags, generally plastic, are ideal for storing smaller, grouped items. The plastic provides a layer in-between the contents and any outside influences. Although bags do not provide the same tension as plastic wrap they allow the contents to move around. Bag sizes are also predetermined and inflexible.



STRAPPING SAFETY TIPS



Keep your team safe when using strapping with these safety tips from Bishops.

It is important you are wearing the correct PPE gear before using strapping. Make sure your team is wearing safety boots, protective glasses and hand protection.

It is also important to use proper tool and strap handling procedures. Always use proper strapping and seals to avoid strap breakage or joint separation while applying strapping to a load or during shipping and handling.

Read the manual and all safety instructions before operating any tool. If you do not have a manual, or need extra copies, contact the manufacturer.

1

Maintain Proper Posture

Establish proper footing, balance and position to prevent injury resulting from loss of balance.

2

Stand To One Side When Tensioning

Position yourself to one side while tensioning the strapping. This means that if the strap breaks, slips in the tool, or disengages, you will not be in the direct line of recoiling strap.

3

Avoid Loose Clothing & Jewellery

Shirt sleeves must be buttoned or rolled up tightly and shirt tails tucked in to prevent them from being caught in the hand tool.

Avoid wearing rings and other jewellery that could become caught in moving parts.

4

Always Use Strap Cutters

Only use cutters specifically designed for strap cutting. Claw hammers, crow bars, chisels and axes will cause tensioned strapping to hazardously fly apart.

5

Dispose Of Strapping Properly

Always place used strapping in a container designated for disposal or recycling, or use a strap chopper (a device that is specially designed for strapping disposal). Never reuse strapping.

6

How To Cut Strapping Safely

When cutting horizontally tensioned strapping, stand against the package and cut to the right of the hold. The strapping will rebound to the right, away from you. This will help prevent personal injury. Other people should remain at a safe distance.

PLASTIC STRAPPING BUCKLES

- Plastic buckles to suit polypropylene strapping
- Quick and easy to use
- 1,000 per box



Item Code	Size	Bishops Code
35021200	12mm	66030045
35021500	15mm	66030048

METAL STRAPPING SEALS

- Designed for use with poly strapping and manual sealing tools
- 1,000 per box



Item Code	Size	Bishops Code
35210115	15mm	66030340
35210119	19mm	66030350

STEEL STRAPPING DISPENSER

- Heavy duty construction for long lasting use
- Easy to use
- Wheels for easier moveability



Item Code	Bishops Code
79011023	66030860

STEEL STRAPPING TOOLS

- Heavy duty construction for long lasting use
- Easy to use

Tensioner



Crimpers



Description	Capacity	Bishops Code
Tensioner	12-19mm	66030820
Crimpers	15mm	66030830
Crimpers	19mm	66030840

HOW TO MANUALLY WRAP A PALLET

The correct use and application of pallet wrap is essential to reduce damages that can occur during storage and transportation of products.

Wrapping might seem like an easy task but it can be challenging, and ineffective packaging can lead to financial losses, damage to goods and potential injuries.

Follow the 5 steps below for secure pallets:

1. Select your stretch wrap

You may wish to use a pallet wrapping tool or wrap the pallet manually. Use a wrap tool that minimises the risks of harming your hands and fingers. If a large number of pallets must be wrapped, then a stretch wrapping machine is recommended.

2. Tie the pallet wrap

Tie the end of the film around a corner of the pallet on which you are working on. This acts as an anchor during the wrapping process, ensuring the stretch wrap does not move.

3. Begin walking around the load

Secure the wrap tightly across both the pallet and the load. Tightly secure the stretch wrap across both the load and the pallet ensuring that the stretch wrap grasps the pallet corners. Wrap the bottom of the load three or more times.

4. Continue upwards to wrap the rest of the pallet

After you have securely wrapped the bottom of the pallet, start wrapping the rest of the load in the same direction. As you move up the pallet, it is recommended you overlap each layer with the next one at around 50%. Be liberal with the stretch wrap, apply more layers depending on the weight of the product on the pallet.

5. Finish wrapping the load

You can finish wrapping the pallet when you reach the top or wrap back down the pallet again if the job looks thin or loose. An insecurely wrapped pallet is a dangerous pallet. Once the pallet is firm, tear the film off the roll and fold it under one of its own layers. This will keep your wrap from coming undone.

Ineffective packing can damage your products & cause financial losses to your business.

Follow our 5 step guide for secure pallets!



STRETCHING FILM WRAP

- Durable polyethylene stretch film
- Excellent puncture resistance
- Useful in stabilising sharp or bulky objects
- Black stretchwrap is ideal for concealing the contents of a pallet (detering theft during storage and transport)
- 500mm wide



Length	Colour	Thickness	Bishops Code
480m	Clear	20µm	66030050
300m	Black	17µm	66030060

DISPENSER

Stretch Film Holder/Dispenser	66030080
-------------------------------	----------

MANUAL FILM WRAP DISPENSER

- Suits 500mm wide polyethylene stretch film
- For manual wrapping of pallets and bulky goods



Item Code	Bishops Code
360HDPW	66030085

BENEFITS OF A PALLET WRAPPING MACHINE

Wrapping pallets by hand can be a very time consuming and physically demanding task. The use of a pallet wrapping machine offers a host of benefits that can help reduce fatigue and improve efficiency.

Material Reduction

When wrapping by hand, the stretch film is not always being stretched to its maximum stretch potential and this can cause a large amount of wasted material. A pallet wrapping machine stretches the film to its maximum potential and creates a consistent layer of film around the pallet.

Fatigue

In order to keep the film stretched, a large amount of force must be continuously exerted which can cause long term harm to body parts. With a pallet wrapping machine, pallets are loaded with a forklift and then wrapped at the press of a button. At this point, workers are free to continue with other work or prepare the next pallet for wrapping.

Efficiency

Continuously wrapping a pallet by hand can become exhausting work and over time the wrapping speed is likely to decrease. Not only do wrapping machines consistently maintain their speed, but they can also wrap at up to twice the speed of average hand wrapping, meaning you can wrap more pallets in a shorter amount of time.



PACKAGING, STATIONERY & SCALES

GENERAL INDUSTRIAL PRODUCTS

BROWN PAPER

- Suitable for packaging and wrapping parcels for postage
- Width: 610mm
- Roll length: 440m
- Roll weight: 18kg
- 67gsm



Length	Bishops Code
440m	66060020

BUBBLE WRAP

- Economical, versatile and effective protection for your products
- Wraps easily around awkward packages and products
- Other sizes and configurations available
- Bubble size: 10mm
- Size: 1.5(w)m x 100(l)m
- Sold per roll



Item Code	Bishops Code
81003067	66030090

STAINLESS STEEL SCISSORS

- Ambidextrous comfort grip handles
- One knife edge blade and one serrated edge blade
- Stainless steel blades
- Ideal for all industrial, food processing and stationery applications
- Length: 230mm



Item Code	Bishops Code
29-900	62547515

MAGNIFYING GLASS

- Ideal for reading maps and fine print
- Glass diameter: 100mm
- Handle length: 100mm



Bishops Code
62080241

DIGITAL COUNTING SCALES

- High performance, high resolution counting scales
- Easy to read digital display panel
- 15kg capacity, accurate to 5g
- Max. display number: 9,999,999
- Pan size: 300 x 200mm
- Overall dimensions: 337(l) x 314(w) x 109(h)mm



Item Code	Bishops Code
KF-H2	86690200

DIGITAL WAREHOUSE SCALES

- Digital LCD backlit display panel
- 600 x 450mm bed
- 300kg capacity

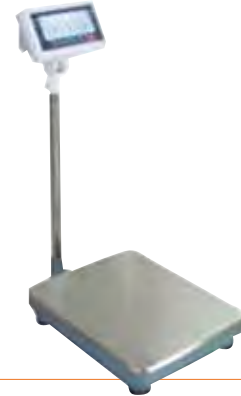

Item Code	Bishops Code
TCS-D	86690100

PLATFORM SCALES

- Platform packing scales
- LCD display with backlight
- 100g increments
- Platform size: 500(w) x 400(d)mm
- Max. capacity: 300kg



Item Code	Bishops Code
86690090	86690090

HARD LEAD CARPENTER PENCIL

- Suitable for DIY use such as marking concrete, brick work and underlay
- Premium graphite core
- Break resistant
- Super bonded lead



Item Code	Bishops Code
ST-148/50	62550040

HOW TO SELECT A PERMANENT MARKER

EASY



At Bishops we have the permanent marker to suit every job. If you can't find what you are looking for, give the Bishops team a call.



General Purpose Markers are suitable for use on most day-to-day surfaces for general marking applications.



Fast Drying Markers work well in applications where the markings may become smudged by contact after application, to maintain their clarity.



Laundry Markers are built to withstand repeated washing and detergents, hot and cold water and dry cleaning. This marker works well with all clothes and linen.



Wet Surface Markers allow for clear marking on wet non-porous surfaces. It becomes permanent once the ink is exposed to air.



Industrial Markers are ideal for use in industrial applications. Suitable for marking both porous and non-porous surfaces and contains xylene ideal for greasy surfaces.



Paint Pens provide extra permanent marking on a range of surfaces. Colour will appear completely opaque, even on dark backgrounds. Paint markers dry quickly and are highly water and fade resistant making them suitable for use both indoors and outdoors.

P10 PAINT MARKERS

- High performance paint marker
- Xylene-free, fast dry formula
- Replaceable, heavy duty tips
- Bold, easy to read marks
- 2mm bullet nib



Colour	Bishops Code
Black	66010030
Red	66010032
Yellow	66010034
White	66010036

P20 PAINT MARKER

- High performance paint marker
- Reversible bullet/chisel tip
- Xylene-free, fast dry formula
- Bold, easy to read marks
- 2 - 4mm tip
- White
- 12 per box



Item Code	Bishops Code
12072011	66010038

ARTLINE 400 SERIES PAINT MARKERS

- Xylene-free and fade resistant ink
- Completely opaque even on dark or transparent surfaces
- Long lasting crisp colour
- Quick drying
- Ideal for indoor and outdoor use
- Bullet nib with 2.3mm line width



Item Code	Colour	Bishops Code	Item Code	Colour	Bishops Code
140001	Black	66010040	140033	White	66010048
140003	Blue	66010042	140007	Yellow	66010047
140009	Pink	66010044	140004	Green	66010049
140002	Red	66010046	-	-	-

PAINT OR PERMANENT MARKER?

Permanent markers dry faster than paint markers, but are not as long lasting. Once dry, paint markers are much more fade resistant and appear opaque even on dark surfaces. Permanent markers are quick and easy to use, whereas paint markers need to be shaken vigorously.





CHALK, INK & PAINT MARKING

GENERAL INDUSTRIAL PRODUCTS

ENGINEERING CHALK

- Economical and semi-permanent marking
- Ideal for industrial grade applications
- Quick and easy to layout jobs
- White
- 80 x 10 x 10mm
- 50 pieces per box



Item Code	Bishops Code
6-EC7510	66510040

CHALK/SOAPSTONE HOLDER

- Metal construction
- Can hold chalk/soapstone of size 13 x 5 x 125mm

Includes:

- Chalk
- Pocket clip



Item Code	Bishops Code
P6-ECD	66510045

BALLMARKER INK, TIPS & BOTTLE

- Permanent and lightfast marks on steel, timber and tyres
- Extremely durable in all environmental conditions
- T400 Ink will mark on any surface, penetrating grease, oil and rust
- Tips feature a unique spring loaded ball valve writing head
- Ink feed controlled by a flexible 'squeeze flow' plastic bottle
- Hardened tips ensure economical ink usage
- Bottle (supplied empty) and tip sold separately

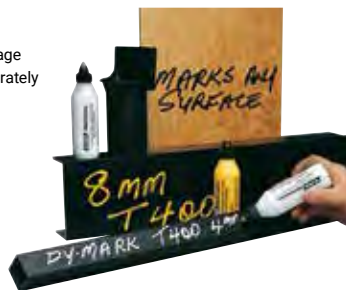

Description	Size	Bishops Code
Ballmarker Ink – Yellow	1L	66010100
Ballmarker Ink – White	1L	66010120
Ballmarker Ink – Red	1L	66010125
Ballmarker Ink – Black	1L	66010130
Ballmarker Bottle	125ml	66010020
Ballmarker Replacement Tip	6mm	66010021

LINE MARKING PAINT

- A fast drying acrylic paint, designed for use with the Line Marking Machine
- Specially formulated to provide long lasting lines
- Ideal for marking on car parks, factories, warehouses, sporting fields and courts
- Toluene-free formula
- A chlorinated rubber, alkyd paint designed for application over asphalt, tarsealed and concrete surfaces
- Fast drying
- 500g aerosol



Colour	Bishops Code	Colour	Bishops Code
Yellow	66010165	Black	66010175
Red	66010168	Blue	66010180
White	66010170	–	–

MINE MARKING OUT PAINT – VERTICAL TRIGGER

- Specially formulated for above/below ground areas
- Two nozzle options available for upright/inverted spray or horizontal spray application
- Bright, highly visible marks on dark surfaces
- Applications include marking out ore zones in grading control, pit walls and survey grid layouts
- Suitable for use with a mine marking handle
- 350g aerosol



Colour	Bishops Code	Colour	Bishops Code
Fluoro Orange	86410550	Red	86410522
Fluoro Pink	86410551	White	86410530
Fluoro Green	86410552	Yellow	86410538
Fluoro Blue	86410553	Fluoro Yellow	86410540
Fluoro Red	86410520	–	–

2 WHEEL SPOT MARKING HANDLE

- Great for marking out jobs
- Ideal for trench digging and landscaping applications
- Lightweight aluminium construction
- Improves efficiency and makes application less fatiguing



Item Code	Bishops Code
40090110	66010155

LINE MARKING MACHINE

- Ergonomic design with built-in side line attachment
- Heavy duty steel construction
- Lightweight, removable handle for spot marking
- Includes utility tray and storage for up to 5 cans of line marking paint
- Line width adjustable between approximately 60mm and 100mm



Item Code	Bishops Code
41800203	66010160

ZINC STENCILS

- Solvent resistant zinc material
- Easy to clean and re-usable
- 50mm



Description	Bishops Code
0–9	66010006
A–Z	66010004

PRIMERS

Etch Primer

- Provides excellent adhesion for metal surfaces that are difficult to bond
- Suitable for use on aluminium, galvanised iron, new steel, alloys and non-ferrous metals

Grey Primer

- Quality primer range for clean and rusty metal surfaces
- Suitable for use on wrought iron railings, fences, gates and other structural steel



66520106

66520108

Description	Size	Bishops Code
Etch Primer	325g Aerosol	66520106
Grey Primer	350g Aerosol	66520108

ZINC GAL PRIMER

- Cold galvanising primer
- Zinc-rich high performance coating, contains 91% zinc in dry film
- Provides true galvanic protection to steel and iron
- Ideal for structural steelwork in industrial environments (tanks, pipes, fences and buildings)



Size	Bishops Code
1L	66520115
4L	66520120

KEYTITE METAL & STEEL PRIMER

- Designed to penetrate lightly rusted surfaces
- Highly durable
- Superior steel wetting and flow characteristics
- Easy to apply
- Grey
- 350g aerosol



Item Code	Bishops Code
GKSGA350	66520100

ZINC GUARD SILVER BRIGHT ANTI-CORROSIVE PAINT

- Metal protection aerosol paint
- Excellent adhesion and long lasting protection
- Protects metal from rust and corrosion
- Suitable for touching up steel and iron
- Bright metallic lustre finish
- Size: 350g



Item Code	Bishops Code
230732007	66520109

DURAGAL® ANTI-CORROSIVE PAINT

- Anti-corrosive silver protective paint and touch-up coating for DuraGal® welds, and other iron and steel products
- DuraGal® is a registered trademark of Onesteel Ltd.
- Fast drying, ready to use, no thinning
- High concentration of aluminium effectively locks out moisture and chemicals
- Size: 350g aerosol



Item Code	Bishops Code
GGDSA	32226040

COLDGAL GALVANISING PAINT

- Organic zinc-rich protective coating
- Designed for long term protection of steel against rust and corrosion
- Provides a long lasting barrier similar in action to galvanising
- 92% zinc in dry film
- Contains 98.5% pure zinc
- 400g aerosol



Item Code	Bishops Code
GGCGA	32226060

COLD GALVANIZING ZINC PAINT

- 93% zinc rich coating in dry film
- Seals out moisture and forms a galvanic cell with iron and steel
- Very good resistance to water, oil, petrol and other chemicals
- Black
- 350g aerosol



Item Code	Bishops Code
D12000	32226050

GET MORE AT BISHOPS ▶

FACE MASKS
From Page 20



RUST PROTECTION, ANTI-SLIP PAINT & PAINT BRUSHES

GENERAL INDUSTRIAL PRODUCTS

ZINC-IT RUST PROTECTION PAINT

- Easy to apply
- Long term protection to steel because of cathodic action
- Metallic zinc coating is universally accepted as the best method of rust prevention
- Flexible continuous protective film
- Does not contain lead
- Excellent weldability
- A single component zinc rich compound with a special epoxy binder
- Contains 93% of the highest purity zinc in the dried film, to give galvanic rust prevention
- Size: 350g aerosol



Item Code	Bishops Code
2085	32002150

BRIGHT ZINC GALVANIC RUST PROTECTION

- Easy to apply
- Long term protection to steel because of cathodic action
- Metallic zinc coating is universally accepted as the best method of rust prevention
- High build protective film provides exceptional moisture protection
- Size: 350g aerosol



Item Code	Bishops Code
2087	32002155

TREADRITE ANTI-SLIP PAINT

- Creates durable anti-slip surfaces
- UV resistant, suitable for interior and exterior use
- Ideal for stairs, entrance ways, railings and more
- Easy to apply with uniform coverage
- Suits residential or industrial applications
- Size: 350g



66520016

66520018

Item Code	Colour	Bishops Code
23063501	Black	66520016
23163505	Yellow	66520018

GET MORE AT BISHOPS



ANTI-SLIP TAPE

Page 57

HOW TO SELECT A PAINT BRUSH

STEP 1: CHOOSE YOUR BRISTLE

Natural: Materials such as Chinese or hog bristle, are best for oil based paints and varnishes. Do not use a natural brush with a water based paint, as the bristle will soak up the water making it limp and unable to hold paint.

Polyester: Hold their shape well, they are ideal for use with both water and oil based paints.

Polyester/Nylon: This blend creates a durable filament that will hold its shape, ideal for use with both water and oil based paints.

STEP 2: CHOOSE YOUR WIDTH

The general rule is, the larger the area, the larger the brush. You will also need to take into account the detail required. Often detailed jobs require smaller brushes, even on larger surfaces.

STEP 3: CHOOSE YOUR STYLE

Trim Brush/General Purpose: Trim brushes are flat and ideal for painting large flat surfaces. They tend to hold more paint to reduce trips to the paint tin.

Cutting In: Cutting in brushes are manufactured on a slight angle, this assists with touch ups and precision angling.

Long Handled: Long handled flat brushes don't require painter to be as close to the painting surface. They are recommended for less detailed applications.

Touch-up Brush: These are small and tapered, designed to pin point touch up spots.



STEP 4: PAINT!

HANDYMAN PAINT BRUSHES

- Wooden handle with black bristles
- Ideal for all general purpose jobs



Width	Bishops Code	Width	Bishops Code
19mm (¾")	62512019	63mm (2½")	62512063
25mm (1")	62512025	75mm (3")	62512075
38mm (1½")	62512038	100mm (4")	62512100
50mm (2")	62512050	-	-

HOW TO CLEAN A PAINT BRUSH

Your method of cleaning will change depending on what type paint you use. No matter what base, before you start make sure that you wipe away any excess paint using a cloth or soft tissue. Squeezing the bristles will help release paint stored in the inner bristle.

WATER BASED PAINTS

Materials: Tap or basin, mild soap, paper towels or old cloth

Steps:

1. Rinse brush with lukewarm water
2. Use soap to carefully wash brush, starting from the tips then moving up
3. Rinse then repeat until the water runs clear
4. Rinse once again to remove any trace of soap
5. Leave to air dry

OIL BASED PAINTS

Materials: Bucket, paint thinner (eg. turpentine), old newspaper, paper towels

Steps:

1. Put used brushes into a bucket.
2. Carefully cover brushes with paint thinner.
3. Allow brushes to sit for several hours, or overnight.
4. Once done, remove paint brushes from bucket
5. To remove excess paint thinner, tap against the side of the bucket
6. Place brushes on old newspaper, dab with paper towel to remove any remaining paint thinner
7. Allow brushes to air dry
8. If paint is still on paint brushes, repeat process

NOTE: Paint thinner is toxic, ensure you are working in an area that has good ventilation and wear proper personal protective equipment.

COMPLETE PRO MINI ROLLERS

- Ideal for DIY applications
- Perfect size for awkward spaces and trim work
- Feature a slip-on and lock design

Fabric Trim

- General purpose use on semi-smooth to rough surfaces
- Suitable for use with all types of paint

Foam Trim

- Close texture foam is easy to clean and gives an even finish
- Suitable for gloss paint on smooth and semi-smooth surfaces

Pipe Roller

- Features three fabric rollers on a curved frame to easily cover pipes and other curved surfaces
- Comes with spare roller cover

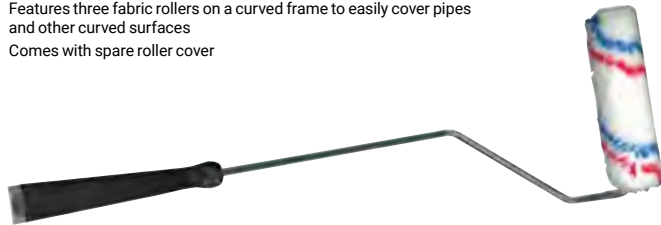

90-110MM COMPLETE ROLLERS & ACCESSORIES

Description	Size	Bishops Code
Complete Fabric Roller	110mm with 390mm Handle	62596321
Complete Foam Roller	110mm with 390mm Handle	62596322
Complete Pipe Roller	90mm with 390mm Handle	62596323
Fabric Covers – 2 Pack	110mm	62596324
Foam Covers – 2 Pack	110mm	62596325
Replacement Handle	390mm	62596326

160MM COMPLETE ROLLERS & ACCESSORIES

Description	Size	Bishops Code
Complete Fabric Roller	160mm with 300mm Handle	62596327
Fabric Covers – 2 Pack	160mm	62596329
Foam Covers – 2 Pack	160mm	62596330
Replacement Handle	600mm	62596332

ALL ROUNDER ROLLER COVERS

- Features a 12mm nap with an end cap
- Sold individually



Size	Bishops Code
180mm	62596236
230mm	62596238
270mm	62596240

ALL ROUNDER ROLLER FRAMES

- Economy cage frame
- Designed to fit standard extension pole



Size	Bishops Code
180mm	62596020
230mm	62596220
270mm	62596222

ROLLER TRAY

- PVC tray suitable for most professional and DIY painting jobs
- Suits 230mm roller or smaller
- Blue



Item Code	Bishops Code
4146	62596225

PAINT ROLLER KIT

- Perfect starter kit for DIY and small jobs

Includes:

- 1 x 230mm paint tray
- 1 x Paint roller cage frame
- 1 x Polyester roller sleeve



Item Code	Bishops Code
25001	62596230



PAINTING EQUIPMENT & TOOLS

GENERAL INDUSTRIAL PRODUCTS

GRAVITY FEED SPRAY GUN

- Stainless steel needle and tip makes it compatible with water-based material
- 18-43psi
- 600ml pot
- Pattern width: approx. 240mm
- Air consumption: 14.5cfm
- Nozzle size: 1.4-2.0mm
- Air inlet: ¼" BSP/NPT



Item Code	Bishops Code
A4-51-YM827WS-14	73660520

SUCTION FEED SPRAY GUN

- High quality nozzle with inside diameter 2.0mm
- Provides a wide-angle of coverage
- All metal construction
- 18-43psi
- 1L pot



	Bishops Code
	73660160

HIGH PRESSURE SPRAY GUN

- Comes with Nitto style fittings and 1L pot
- Delivers extremely fine atomisation
- Can be used for most professional applications including automobile jobs
- Suitable for polyurethane, 2 Pak and enamel
- Nozzle ID: 1.7mm
- Required pressure: 50-70psi
- Air consumption: 7.77cfm
- 1L pot



	Bishops Code
	73660140

5 PIECE PROFESSIONAL AIR KIT

- With Nitto style fittings
- Includes:**
 - Tyre pressure gauge
 - Engine cleaner gun
 - Air duster
 - High pressure spray gun
 - Coil hose



Description	Bishops Code
5 Piece Set	736602020

PAINT MIXER

- Suitable for mixing paint and various low density materials
- Has a hexagonal fluted shaft and the red powder coating provides a high level of protection against rust
- Preferably used with a variable speed reversible drill with minimum power between 400 to 600W
- Depending on the density of the material, the recommended speed is between 200 to 700rpm
- The mixer should be inserted well into the paint before the drill is turned on and the mixer should come to a complete stop before it is removed after mixing
- Fits 9.5mm drill
- Diameter: 60mm
- Overall length: 400mm



Item Code	Bishops Code
PMX/60	62512990

HOW TO PREPARE A SURFACE FOR PAINTING

Getting a professional finish is all about the preparation. Making sure that your surface is clean, smooth and free of imperfections is paramount.

Follow the steps below to make sure you get the best finish possible.

1. Remove any hooks, fixtures and light switch covers
2. Lay a drop sheet on flooring and any furniture
3. Dust and clean the walls. We suggest you use Sugar Soap diluted with water (follow instructions stated on the bottle). Once clean rinse again with water, then leave to dry
4. Scrape back any cracked or flaking paint with a paint scraper. Any bumps, smooth away with sandpaper and fill any dents with a pre-mixed filler
5. Prime the wall. Use a water-based option for new drywall and oil-based for walls with any heavy stains or if the wall has panelling. Leave to dry
6. Once dry, apply painters tape to any edging such as skirting boards or window edges

PAINT SCRAPERS

- Comes with Duragrip handle and steel blades
- Blades are fixed



Blade Width	Bishops Code	Blade Width	Bishops Code
38mm	62560030	90mm	62560375
50mm	62560050	100mm	62560400
65mm	62560100	-	-

SAFETY STEP

- Made from linear low density polyethylene (LDPE)
- Non-slip tape on stepping surfaces
- Orange
- 475(l) x 475(w) x 360(h)mm

Rolling Insert:

- To help transport your safety step
- Spring loaded castors that retract when weight is applied
- Wheel diameter: 25mm



Item Code	Description	Bishops Code
SSR002	Safety Step	62548108
SSR003	Rolling Insert For Safety Step	62548105

SINGLE SIDED ALUMINIUM STEP LADDER

- EN14183 Standard
- 3 steps and platform
- Load rating: 150kg
- Size when open: 90(h) x 57(d) x 52.5(w)cm
- Height of top step: 50cm
- Platform height: 87cm
- Weight: 3.5kg



Item Code	Bishops Code
Q0171-4A	62548110

WATCH YOUR STEP

In 2021, 19 Australian workers a year die as a result of falling from a height.*

Height safety is not limited to rooftops and towers, it starts from the first step. Make sure you and your team are staying safe at heights.

Contact Bishops for a free workplace assessment

*Safework Australia

HOW TO CHOOSE THE CORRECT LADDER**What is the difference between Domestic and Industrial Ladders?**

Industrial ladders must have a minimum load capacity of 120kg, whereas a domestic ladder must have a minimum load rating of 100kg. Both industrial and domestic ladders should be clearly labelled stating whether they are suitable for industrial or domestic use.

Domestic ladders are not suitable for use in the workplace. If you are unsure of the rating of a ladder, ask for a statement from the manufacturer.

What is the difference between Fibreglass and Aluminium Ladders?

Aluminium is a more popular and versatile option. They are strong yet lightweight, making them easy to manoeuvre and transport. However aluminium is also highly conductive, making it unsuitable for any application where the user may come into contact with electricity.

Fibreglass is non-conductive, making it an ideal choice for any application where the user may come into contact with electricity, such as working near power lines or electrical outputs. Fibreglass varieties are also flame resistant and don't conduct heat and as well as aluminium. Therefore, it won't heat up as much when left in the sun. In comparison to aluminium, fibreglass is not as lightweight and more expensive.

FIBREGLASS SINGLE SIDED STEP LADDERBLACK  JACK

- AS/NZ 1892.3: 1996
- Fibreglass rails with aluminium steps
- Heavy duty construction
- 5 steps
- Red with yellow top and feet
- Load rating: 150kg
- Closed height: 1.87m
- Size when open: 1.74(h) x 1.09(d) x 0.58(w)m
- Weight: 10.6kg



Item Code	Bishops Code
Q0211-6NA	62548210



STEP LADDERS

GENERAL INDUSTRIAL PRODUCTS

ALUMINIUM DOUBLE SIDED STEP LADDER

- AS/NZ 1892.3: 1996
- 7811 steps each side
- Load rating: 150kg
- Closed height: 3.59m
- Size when open: 3.51(h) x 2.34(d) x 0.81(w)m
- Weight: 28.5kg



BLACK JACK

FIBREGLASS DOUBLE SIDED STEP LADDER

- AS/NZ 1892.3: 1996
- Fibreglass rails with aluminium steps
- Heavy duty construction
- 7 steps on each side
- Load rating: 150kg
- Closed height: 2.45m
- Size when open: 2.34(h) x 1.63(d) x 0.65(w)m
- Weight: 20.1kg



BLACK JACK

Item Code	Bishops Code
Q0191-12A	62548240

Item Code	Bishops Code
Q0211-8NA	62548215

STEP LADDER SAFETY RULES

✓ Dos

- Face the ladder while climbing.
- Always carry tools in toolbelt holster or pouch and not in hands.
- Remember the three point rule: At least two hands and one foot, or two feet and one hand should be in contact with the ladder all the time.
- If two hands are needed to be free for a brief period for light work, keep two feet at the same step and the body (knees or chest) supported by the step ladder to maintain three points of contact.
- Place the ladder on a firm and level base.
- If you must place the ladder in front of a door, make sure it is locked or blocked off.
- Use the right height for the job.
- The top two steps are not safe to stand on.
- Fully open the ladder and lock spreaders in place.
- Use ladders with non-slip feet.

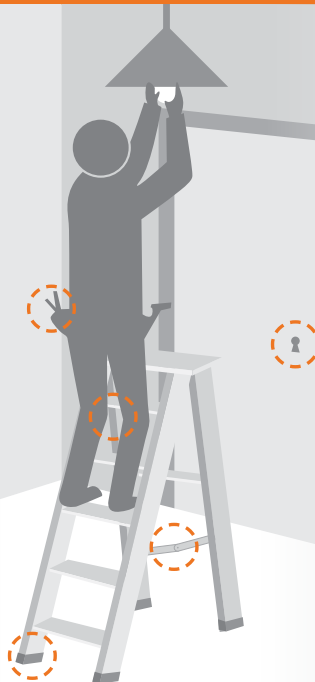

✗ Don'ts

- Don't hold up and lean the ladder against a surface.
- Don't overreach.
- Don't carry heavy objects while climbing a ladder.
- Don't place the ladder on uneven, soft ground without flat board.
- Don't use ladder with slippery steps or damaged tiles.

For more information call Bishops

ALUMINIUM EXTENSION LADDER BLACK JACK

- EN131 standard
- 20 steps
- Ladder height: 3.65–5.15m
- Max. width: 454mm
- Weight: 12.55kg
- Load rating: 150kg

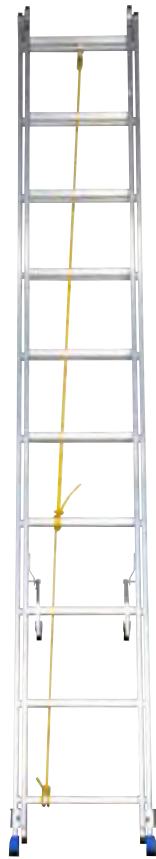

Item Code	Bishops Code
Q0120-20	62548420

FIBREGLASS ORDER PICKER PLATFORM LADDER

- Safety platform ladder
- Suitable for warehouses and order picking
- 6 steps
- Load rating: 150kg
- Platform height: 131cm
- Overall height: 1.7m



Item Code	Bishops Code
Q0250-6NA	62548120

FIBREGLASS EXTENSION LADDER BLACK JACK

- AS/NZS 1892.3: 1996
- Heavy duty construction
- Fibreglass rails with aluminium steps
- Lightweight and easy to handle
- Load rating: 150kg



Steps	Ladder Height	Weight	Bishops Code
20	3.26–5.37m	19.9kg	62548360
28	4.37–7.67m	30kg	62548380

GET MORE AT BISHOPS



TOOL LANYARDS

Page 31

SAFETY BOOTS

Page 82





SCAFFOLDING UNITS & TOOLS

GENERAL INDUSTRIAL PRODUCTS

ZIPPY SCAFF FOLDING MOBILE SCAFFOLD UNIT

- Suitable for a wide range of trades and applications
- Compact, lightweight and transportable
- Foldable and easy to erect
- Easily adjustable to different working heights
- Deck is made with slip-resistant plywood and features built-in ladder access, while frame is lightweight aluminium
- 225kg working load
- Overall dimensions for base unit: 1.96(l) x 0.74(w) x 1.96(h)m
- Max. standing height: 1.4m and 1.9m with extension
- Base weight: 42kg
- Extension weight: 19kg



Description	Bishops Code
Folding Mobile Scaffold Unit	84550010
Extension for Folding Mobile Scaffold Unit	84550012

2600 SERIES MOBILE SCAFFOLD TOWER & ACCESSORIES

- Robust aluminium scaffold frames
- Modular components to create a mobile scaffold tower
- Complies to standards AS/NZS1576.3 - 1995
- The fully TIG welded ladders provide extra strength and a longer service life



Description	Size	Bishops Code
Aluminium Scaffold Frame	1.2 x 1.0m	84550201
Aluminium Scaffold Frame	1.2 x 1.5m	84550204
Horizontal Brace – Yellow	2.4m	84550206
Diagonal Brace – Blue	2.4m	84550208
Plain Brace – Red	1.2 x 2.4m	84550210
Deck	2.4m	84550212
Deck With Hatch	2.4m	84550214
Castor With Adjustable Collar	200mm	84550216
Outrigger	3.0m	84550218
Toe-Board	1.2m x 165mm	84550232
Toe-Board	2.4m x 165mm	84550234
Straight Ladder	3m	84550222
Straight Ladder	3.6m	84550224
Straight Ladder	4.2m	84550226
Straight Ladder	4.8m	84550228
Straight Ladder	5m	84550230

SCAFFOLD KEY

- Heavy duty steel
- Rounded handle for more ergonomic use
- Perfect accessory for most scaffolding applications
- Length: 24mm



Bishops Code
85075498

SCAFFOLD HAMMER

- Dual-purpose tool used for scaffold assembly
- Forged from high tensile carbon manganese steel for strength
- Good balance and weight
- Forged, not turned tapered point ideal for aligning
- Will not break off next to head, as can happen with cast products
- Weight: 830g



Item Code	Bishops Code
5HSC	63574690

SCAFFOLDING BLUE BOOK

- Organise everything you need to manage scaffolding systems with the Blue Book
- Section 1 - Details the components available within the Scafftag system
- Section 2 - Contains handover certificates
- Section 3 - Contains inspection reports
- Section 4 - Contains fault notification forms
- Pen included



Item Code	Bishops Code
857313	55075495

GET MORE AT BISHOPS



HARD HATS

Page 27

TARPAULINS VS SHADECLOTH

Make sure you choose the right product for the job. Knowing the difference between these two will help you pick the right solution every time.

Shade Management

Generally, tarpaulins are nearly completely opaque. Therefore, the amount of visible light that penetrates is very minimal, if any. Use tarpaulins for full sunlight protection, not for sunlight permeation. Shadecloth will allow a variable amount of sunlight through depending on the shade factor. This refers to the ability of the cloth to absorb and reflect visible and invisible light. Darker colours will absorb more light and create a deeper shade underneath.

Water & Rain Management

Tarpaulins have a fully closed material making them completely waterproof. This makes them ideal for protective duties or preventing weathering to components stored outside. Shadecloth has a semi-permeable construction, making it water resistant but not waterproof. This makes it ideal for applications including greenhouses and orchards.

Durability

Both tarpaulin and shadecloth are ideal for continuous outdoor exposure. However, good quality tarpaulins are often thicker and have reinforced hems, making them less susceptible to ripping and tearing than lighter shadecloth.

Ultraviolet (UV) Light

Both tarpaulins and shadecloth can offer excellent UV protection and resistance. For the best UV protection in shadecloth, choose a dark colour with a close and heavy construction.

If you need more information about finding the best solution, contact Bishops today.

PE TARPAULIN

- Polyethylene tarpaulin
- Waterproof and weather resistant



Description	Colour	Weight	Size	Bishops Code
General Duty	Green	120gsm	3.65 x 4.85m	66550110
General Duty	Blue	120gsm	4.85 x 7.3m	66550120
Heavy Duty	Silver/Green	230gsm	6 x 7.3m	66550140
Heavy Duty	Silver	230gsm	7.3 x 7.3m	66550160
Super Heavy Duty	Silver	260gsm	7.3 x 11m	66550180

PVC TARPAULIN

- Industrial duty
- Green
- Waterproof and weather resistant
- Suitable for use as ground sheets, wind breaks, banners, and water tank covers
- 550gsm



Size	Bishops Code
9.15 x 9.15m	66550360
9.15 x 12.2m	66550380
9.75 x 10.97m	66550390

GROMMETS

- Used to repair canvas, tarpaulins, tents, awnings, sail cloth, lawn furniture, pool covers and more
- Solid brass and rust resistant
- 10mm
- Replacement grommets also available



Item Code	Description	Bishops Code
GRMT/3-8/ST	Grommet Kit – Includes 12 Brass Grommets, Hole Punch, Backer Block, Setting Tool & Anvil	66550900
GRM/B/3-8/ST12	Replacement Grommets – 12 Pieces	66550910

EXTENSION & COMPRESSION SPRING KITS



Item Code	Description	Kit Size	Bishops Code
CA101	Extension Springs – 12 Sizes: 25–120mm, Length 5–12mm	48 Pieces	40410110
CA102	Compression Springs – 12 Sizes: 37–100mm, Length 5–20mm	72 Pieces	40410120

200 PIECE SPRING GRAB KIT

- Compression and extension springs
 - Comes in hard plastic case for handy storage
- Includes:**

- Compression Springs 8 Sizes – 5.5 x 38mm to 9.5 x 16mm
- Extension Springs 11 Sizes – 4 x 79.5mm to 8.5 x 36.5mm



Description	Bishops Code
200 Piece Spring Grab Kit	40420054



CONSTRUCTION & FENCING PRODUCTS

GENERAL INDUSTRIAL PRODUCTS

POLYETHYLENE BUILDERS FILM

- Polyethylene material
- Thickness: 100µm
- Roll size: 2 x 50m
- Black



Item Code	Bishops Code
23	66050060

HEAVY DUTY BACKING GROUT 5137

- Non-shrink for high tolerance applications
- Easy mixing
- Exhibits excellent impact and vibration characteristics
- Long life backing of crushing equipment, high strength bearing supports
- Size: 10kg



Item Code	Bishops Code
E951377	32414150

BRONZE RODS

- LG2
- Grade AS1565-83600



Dimensions	Weight	Bishops Code
ROUND BARS		
12.7(dia) x 300(l)mm	0.5kg	89225012
19.05(dia) x 300(l)mm	1.0kg	89225018
25.4(dia) x 300(l)mm	1.5kg	89225024
31.75(dia) x 300(l)mm	2.45kg	89225031
38.1(dia) x 300(l)mm	3.3kg	89225038
44.45(dia) x 300(l)mm	4.5kg	89225044
50.8(dia) x 300(l)mm	5.75kg	89225051
63.5(dia) x 300(l)mm	9.0kg	89225063
RECTANGULAR BARS		
12.7(w) x 25.4(d) x 300(l)mm	1.3kg	89230020
12.7(w) x 38.1(d) x 300(l)mm	4.6kg	89230050
25.4(w) x 50.8(d) x 300(l)mm	7.75kg	89230070
25.4(w) x 63.5(d) x 300(l)mm	6.25kg	89230100
38.1(w) x 63.5(d) x 300(l)mm	6.1kg	89230105

NYLON RODS

- Length: 1.0m



Diameter	Bishops Code	Diameter	Bishops Code
20mm	89250020	60mm	89250060
25mm	89250025	80mm	89250075
30mm	89250030	100mm	89250100
40mm	89250040	150mm	89250150
50mm	89250050	200mm	89250200

GALVANISED TIE WIRE

- Galvanised to resist corrosion
- Soft and easy to use
- 5kg roll



Diameter	Gauge	Length	Bishops Code
1.6mm	16	320m	66580100
2.0mm	14	200m	66580120
2.5mm	12	120m	66580125

STAR PICKETS & CAPS

- Suitable for supporting wire or wire mesh fencing
- Can also be used in agricultural jobs for supporting trees or vines
- Length: 1.8m
- Picket caps sold separately

Star Picket Caps

- Hi-vis yellow
- Plastic
- 100 pack

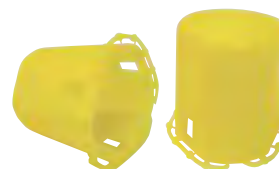

Description	Bishops Code
Star Picket	63575020
Star Picket Caps	63575010

STAR DROPPER REMOVER & HAMMER

Remover

- Used for removing star droppers (also called star pickets or fencing droppers)
- Also used for removing selected pipes and steel pegs
- Made from high tensile steel for durability and long life
- Gripper bites efficiently into dropper for easy extraction
- Long handle for excellent leverage

Hammer

- Used for driving in star (fencing) droppers
- Also used to drive in marker pegs, stakes, concreting stakes etc.
- Heavy 8kg unit drives droppers very quickly and efficiently
- Solid steel handles and slug welded together (not to pipe) gives great strength



Item Code	Description	Bishops Code
5SDSH	Hammer	63575110
5SDR	Remover	63575150

HOW TO SELECT A PADLOCK

Security

How valuable are the items you are securing?
The more valuable, the higher security padlock needed.
High security padlocks with strong and robust designs provide maximum resistance to tampering.

Environment

Standard padlocks are suitable for indoor applications.
If the padlock is outdoors, use an all-weather lock.

Use and Suitability

Make sure the shackle will fit the hasp or chain without leaving room for a stray bolt cutter. Padlock strength should match the strength of your other security measures. Thieves will go for the weakest link.

Key Variations

How many people are going to need access to the locked area or item? Locks can be keyed-alike (KA), keyed to differ (KD), master keyed or combination.

Keyed alike keys give one key access to all locks, providing convenient access to all locked areas or items. Keyed to differ locks require unique keys for each lock, ideal when specific permissions are needed for each locked area. Master keyed locks have unique keys, but can also be opened with a master key ideal for the site manager, or if a unique key gets misplaced. If many staff need access to the lock area or item, opt for a combination lock.

BRASS PADLOCKS

- Suitable for general security applications
- Resistant against rust and corrosion
- Brass body and hardened steel shackle
- Comes with a set of three keys



Width	Shackle Height	Shackle Dia.	Bishops Code
20mm	11mm	3.2mm	62588020
30mm	16mm	5.4mm	62588030
40mm	19mm	6.3mm	62588040
50mm	25mm	8.7mm	62588050
63mm	32mm	10.7mm	62588060

MEDIUM SECURITY BRASS PADLOCKS **Master Lock**

- Hardened steel shackles for increased cut resistance
- Stylish and strong solid brass and nickel plated bodies available
- Dual locking mechanism increases resistance to pulling and prying
- Available keyed to differ (KD) or keyed alike (KA)
- Lifetime guarantee



Item Code	Size	Keyed	Shackle Opening Height	Shackle Dia.	Bishops Code
SINGLE PADLOCKS					
120DAU	20mm	KD	11mm	4mm	62586270
0120BOX-1A31	20mm	KA	11mm	4mm	62586271
130DAU	30mm	KD	16mm	5mm	62588505
0130BOX-1B005	30mm	KA	16mm	5mm	62586273
130DLJAU	30mm	KD	65mm	5mm	62588086
140DAU	40mm	KD	22mm	6mm	62588510
140DLFAU	40mm	KD	38mm	6mm	62586275
0140LFBX-1G022	40mm	KA	38mm	6mm	62586276
2240DAU	40mm – Shrouded	KD	20mm	6mm	62588090
640DAU	40mm – Nickel Plated	KD	23mm	6mm	62588118
150DAU	50mm	KD	25mm	7mm	62588520
0150BOX-1K062	50mm	KA	25mm	7mm	62586277
MULTI-PACKS					
120QAU	20mm – 4 Pack	KA	11mm	4mm	62588082
130TAU	30mm – 2 Pack	KA	16mm	5mm	62588085
130QAU	30mm – 4 Pack	KA	16mm	5mm	62588083
140QAU	40mm – 4 Pack	KA	22mm	6mm	62588089

MEDIUM SECURITY COMBINATION PADLOCKS

- Weather resistant, heavy duty, resettable and key override options available
- Hardened steel shackle
- Lifetime guarantee



Item Code	Description	Size	Shackle Opening Height	Shackle Dia.	Bishops Code
604DAU	Brass	40mm	26mm	6mm	62588216
175DAU	Brass	51mm	25mm	8mm	62588219
0178	Die Cast	51mm	25mm	8mm	62588217
1174D	Stainless Steel	57mm	28mm	8mm	62588215
1500DAU	Dial – Stainless Steel	48mm	19mm	7mm	62588211

EXCELL™ BRASS COVERED LAMINATED STEEL PADLOCKS **Master Lock**

- Laminated steel core for greater durability
- Weather resistant outer casing for durability
- Exclusive octagonal boron-carbide shackle for maximum cut resistance
- Dual ball bearing locking mechanism
- 4 pin cylinder for superior pick resistance
- Lifetime guarantee
- Single locks are keyed to differ, multi-packs are keyed alike



Item Code	Size	Shackle Opening Height	Shackle Dia.	Bishops Code
SINGLE PADLOCKS				
M5BDAU	50mm	25mm	9mm	62588140
M5BDLHAU	50mm – Long Shackle	51mm	9mm	62588143
M15BDAU	64mm	32mm	11mm	62588109
MULTI-PACKS				
M5BQAU	50mm – 3 Pack	25mm	9mm	62588142



PADLOCKS & CABLE TIES

GENERAL INDUSTRIAL PRODUCTS

PROSERIES® HIGH SECURITY PADLOCKS

- Heavy duty laminated steel body provides maximum resistance to physical attacks
- Durable thermoplastic cover on the weather tough locks protects padlock from corrosion for excellent durability in outdoor environments
- Integrated keyway cover keeps out dust, dirt and grime
- Boron alloy shackles for excellent cut resistance
- Stainless steel shackles available on request
- Dual ball bearing locking mechanism offers excellent resistance to pulling and prying attacks
- Ideal for trucks and transport containers, site fences, site boxes, perimeter gates and sheds
- Available keyed to differ, keyed alike and master keyed
- Restricted key systems available



Item Code	Size	Shackle Opening Height	Shackle Dia.	Bishops Code
WEATHER TOUGH				
6121K	54mm	29mm	8mm	62588152
6125K	61mm	35mm	10mm	62588154
6127K	67mm	35mm	11mm	62588156
SOLID IRON SHROUD				
6321K	54mm	19mm	8mm	62588162
6325K	61mm	19mm	10mm	62588164
6327K	67mm	19mm	11mm	62588166
SOLID STEEL CASE				
7030K	40mm	27mm	6mm	62588124
7040K	44mm	30mm	8mm	62588128
7045K	44mm – Shrouded	30mm	8mm	62588130
7050K	51mm	37mm	10mm	62588132
SOLID BRASS				
6840K	44mm	30mm	8mm	62588062

LAMINATED STEEL PADLOCKS

- Strong laminated steel bodies for superior strength
- Hardened steel and boron alloy shackles for superior cut resistance
- Lifetime guarantee
- 312DAU and 312TRIAU feature high-tech thermoplastic shell designed to withstand the elements
- Single locks are keyed to differ (KD), multi-packs are keyed alike (KA)



Item Code	Size	Keyed	Shackle Opening Height	Shackle Dia.	Bishops Code
SINGLE PADLOCKS					
3DLFAU	40mm	KD	38mm	7mm	62588103
1DAU	44mm	KD	24mm	8mm	62588104
5DAU	51mm	KD	25mm	10mm	62588106
MULTI-PACKS					
3TAU	40mm – 2 Pack	KA	19mm	7mm	62588105
3008DAU	40mm – 4 Pack	KA	19mm	7mm	62588101
5TRILFAU	51mm – 3 Pack	KA	38mm	10mm	62588107
312TRIAU	40mm – 3 Pack Thermoplastic Covered	KA	25mm	7mm	62588150

SHROUDED STEEL DISC PADLOCK



- Double deadbolt locking mechanism and fully shrouded design minimises shackle exposure
- 4 pin cylinder
- Includes key retaining feature
- 70mm body diameter
- Shackle opening height: 19mm
- Shackle diameter: 10mm



Item Code	Bishops Code
0040D	62588120

FULLY ENCLOSED SHACKLE PUCK LOCK



- Ideal for vans, trucks, gates and vending
- Hardened steel body
- 6-pin ProSeries cylinder
- Lifetime warranty
- Diameter: 73mm



Item Code	Bishops Code
6270	62588210

GET MORE AT BISHOPS

LOCKOUT PADLOCKS

Page 48

NATURAL CABLE TIES

- Nylon cable ties are manufactured from virgin nylon 6/6 and are UL94V-2 flammable rated
- Handy retail packs



Item Code	Width	Length	Quantity	Bishops Code
CT103NTCD	3mm	100mm	100	64510020
CT154NTCD	4mm	150mm	100	64510030
CT204NTCD	4mm	200mm	100	64510035
CT304NTCD	4mm	300mm	100	64510048
CT205NTCD	5mm	200mm	100	64510040
CT255NTCD	5mm	250mm	100	64510045
CT305NTCD	5mm	300mm	100	64510050
CT405NTCD	5mm	400mm	25	64510052
CT455NTCD	5mm	450mm	25	64510054
CT308NTCD	8mm	300mm	25	64510060
CT408NTCD	8mm	400mm	25	64510100
-	8mm	400mm	100	64510041
CT559NTCD	9mm	550mm	25	64510064

BLACK CABLE TIES

- UV stabilised to resist material breakdown and increase service life
- Various sizes and pack quantities available



Item Code	Width	Length	Quantity	Bishops Code
CT103BKCD	3mm	100mm	100	64510130
CT154BKCD	4mm	150mm	100	64510140
CT204BKCD	4mm	200mm	100	64510150
CT254BKCD	4mm	250mm	100	64510160
CT304BKCD	4mm	300mm	100	64510170
CT205BKCD	5mm	200mm	100	64510250
CT255BKCD	5mm	250mm	100	64510255
CT255BK	5mm	250mm	500	64510260
CT305BKCD	5mm	300mm	100	64510350
CT405BKCD-100	5mm	400mm	100	64010360
CT455BKCD-100	5mm	450mm	100	64010365
CT308BKCD	7mm	300mm	100	64510080
TS1-1-76450B	7.6mm	450mm	100	64510482
TS1-1-76300B	7.8mm	300mm	100	64510478
TS1-1-78550B	7.8mm	550mm	100	64510486
CT208BKCD	8mm	200mm	25	64010370
CT308BKCD	8mm	300mm	25	64010380
CT408BKCD	8mm	400mm	25	64510480
CT408BKCD-100	8mm	400mm	100	65410485
TS1-1-88550B	8.8mm	550mm	100	64510490
CT559BKCD	9mm	550mm	25	64510121
CT759BKCD	9mm	750mm	25	64510066
CT6512BKCD	12mm	650mm	25	65410488
35600222	12mm	650mm	100	64510070

CABLE TIE ASSORTMENTS

- Available in assorted materials, colours and sizes to suit all types of applications



Item Code	Colour	Size	Quantity	Total Pack Qty	Bishops Code
CTP07	Assorted	3(w) x 100(l)mm	300	500	64510600
		3(w) x 150(l)mm	200		
CTP10	Natural	3(w) x 100(l)mm	25	75	64510610
		5(w) x 120(l)mm	25		
		5(w) x 200(l)mm	25		
CTP13	Black	3(w) x 100(l)mm	50	150	64510615
		5(w) x 120(l)mm	50		
CTP18	Assorted	4(w) x 150(l)mm	75	75	64510620
		3(w) x 100(l)mm	200		
CTCP10	Black	4(w) x 150(l)mm	200	1,000	64510630
		5(w) x 200(l)mm	400		
		5(w) x 300(l)mm	200		

INDUSTRIAL NYLON CABLE TIES

- Industrial cable ties designed for the mobile worker
- Designed for use wherever you need to bundle wire, cable or pipe
- Easily adjustable and made from polyamide 66
- Available in black and white
- Halogen free
- UV resistant (black only)



Item Code	Colour	Quantity	Item Code	Colour	Quantity
100 X 2.5MM			290 X 3.5MM		
ALCTIE90B	Black	100	ALCTIE290MDB	Black	100
ALCTIE90B/1000	Black	1,000	ALCTIE290MDW	White	100
ALCTIE90W	White	100	290 X 4.6MM		
ALCTIE90W/1000	White	1,000	ALCTIE290BL	Blue	100
140 X 3.6MM			ALCTIE290GN	Green	100
ALCTIE140B	Black	100	ALCTIE290RD	Red	100
ALCTIE140B/1000	Black	1,000	ALCTIE290YW	Yellow	100
ALCTIE140W	White	100	290 X 7.5MM		
ALCTIE140W/1000	White	1,000	ALCTIE290FB	Black	100
160 X 4.6MM			370 X 4.8MM		
ALCTIE160B	Black	100	ALCTIE360SB	Black	100
ALCTIE160W	White	100	ALCTIE360SB1000	Black	1,000
199 X 4.6MM			ALCTIE360SW	White	100
ALCTIE185B	Black	100	ALCTIE360SW1000	White	1,000
ALCTIE185B/1000	Black	1,000	370 X 7.5MM		
ALCTIE185W	White	100	ALCTIE360FB	Black	100
ALCTIE185W/1000	White	1,000	ALCTIE360FB/500	Black	500
200 X 2.5MM			370 X 7.6MM		
ALCTIE200LDB	Black	100	ALCTIE360FW	White	100
ALCTIE200LDW	White	100	ALCTIE360FW/500	White	500
200 X 3.5MM			430 X 4.6MM		
ALCTIE200MDB	Black	100	ALCTIE430B	Black	100
ALCTIE200MDW	White	100	450 X 7.5MM		
200 X 4.6MM			ALCTIE450FB	Black	100
ALCTIE200MHB	Black	100	510 X 12.7MM		
ALCTIE200MHW	White	100	ALCTIE510XHDB	Black	25
ALCTIE200BL	Blue	100	530 X 4.6MM		
ALCTIE200GN	Green	100	ALCTIE530B	Black	100
ALCTIE200RD	Red	100	540 X 7.5M		
ALCTIE200YW	Yellow	100	ALCTIE540FB	Black	100
200 X 7.5MM			610 X 12.7MM		
ALCTIE200FB	Black	100	ALCTIE610XHDB	Black	25
250 X 4.6MM			770 X 8.7MM		
ALCTIE250B	Black	100	ALCTIE770HDB	Black	25
ALCTIE250B/1000	Black	1,000	ALCTIE770HDW	White	25
ALCTIE250W	White	100	1,160 X 8.7MM		
ALCTIE250W/1000	White	1,000	ALCTIE1100HDB	Black	25
288 X 4.6MM			1,530 X 8.7MM		
ALCTIE290B	Black	100	ALCTIE1530HDB	Black	25
ALCTIE290B/1000	Black	1,000	-	-	-
ALCTIE290W	White	100	-	-	-
ALCTIE290W/1000	White	1,000	-	-	-

SPECIAL ORDER: PLEASE QUOTE ITEM CODE UPON ORDERING THIS PRODUCT

GET MORE AT BISHOPS



CUTTING PLIERS

Page 207

EXTENSION LEADS

- Neon socket
- 3 x 1.5mm plugs
- 240V
- Constructed from durable PVC
- Australian Standards compliant



Description	Lead Power	Socket Power	Length	Colour	Bishops Code
Standard Duty	10A	10A	3m	White	62043106
Heavy Duty	15A	10A	5m	Red	62043099
Heavy Duty	15A	10A	10m	Red	62043110
Heavy Duty	15A	10A	20m	Red	62043120
Heavy Duty	15A	10A	25m	Yellow	62043125
Heavy Duty	15A	10A	30m	Red	62043130
Extra Heavy Duty	15A	15A	20m	Blue	62043103

240V RETRACTABLE ELECTRIC CABLE REELS

- High quality impact resistant polypropylene covers
- Automatic and consistent speed control mechanism
- Swivelling steel wall bracket
- Thermal overload protection
- Impact tested to IK08 with a top rating of IK10 possible
- IP24 rating
- Maximum power when coiled is 1,000W, when uncoiled 2,000W
- Supplied with 20m of cable

Complies With:

- AS/NZ5 3000
- CE approved



Item Code	Power	Cable Size
CR30050	10A	3 x 1.5mm ²
CR30060	15A	3 x 2.5mm ²

SPECIAL ORDER: PLEASE QUOTE ITEM CODE UPON ORDERING THIS PRODUCT

4 SOCKET EXTENSION LEAD REEL WITH 10M LEAD

- Comes in a hard cassette case with retractable carry handle for a more compact design
- Comes with knob handle for manual winding of cable
- Coloured yellow and black for high visibility
- Fitted with four 13amp outlets
- Plug prongs: 3 x 1mm
- Plug power: 10A
- 240V
- 10m lead
- 240(w) x 255(h) x 125(d)mm
- Weight: 1.97kg



Lead Length	Bishops Code
10m	62043134

SINGLE SOCKET EXTENSION LEAD REEL WITH 20M LEAD

- Self-retracting cable reel housed in a strong plastic portable case
- Coloured yellow and black for high visibility
- One 13amp outlet
- Plug prongs: 3 x 1.5mm
- Plug power: 10amp
- 240V
- 20m lead
- 250(w) x 310(h) x 150(d)mm
- Weight: 5.8kg



Lead Length	Bishops Code
20m	62043144

EXTENSION LEAD HOOK

- Elevates leads and cables
- UV stabilised plastic in hi-vis yellow
- Dimensions: 245(l) x 120(w)mm
- 5 per pack



Item Code	Bishops Code
62043145	62043143

GET MORE AT BISHOPS



ELECTRICAL TAPE

Page 347

SURGE PROTECTED POWER PLUG

- Surge protector for mains power point
- Protects electronic equipment
- Operating light indicator
- Vertical design



Item Code	Bishops Code
DA14	62043025

SURGE PROTECTED POWER BOARDS

- Slimline powerboards
- Surge protected
- Manual reset button
- Fitted with 1m mains cord
- 240V, 10A



62043060



62043055

Description	Bishops Code
4 Outlet	62043050
6 Outlet	62043055
4 Outlet – Individual Switches	62043060
6 Outlet – Individual Switches	62043065

EARTH LEAKAGE UNITS

- 4-way outlet
- Residual current device
- Safety switch protection
- Includes overload circuit breaker and stunt trip coil
- Fitted with combined MCB/RCD
- Australian made



70530051



70530052

Description	Power	Bishops Code
4 Outlet Portable Unit	10amp	70530051
4 Outlet Heavy Duty Portable Unit	10amp	70530053
4 Outlet Heavy Duty Portable Unit	15amp	70530052

LIFEGUARD EARTH LEAKAGE OUTLETS

- Single phase portable socket outlet assembly
- Manufactured in high impact polyethylene
- Double insulated and weatherproof (IP66)
- Fitted with double pole, self-switching socket outlets
- Comes with industrial strength 10kA RCD/MCB
- Lightweight, portable, practical and safe
- Compact and robust



Outlet	Amps	Part Number
4-Way Outlet	10amp	86690363
6-Way Outlet	10amp	86690364
6-Way Outlet	15amp	86690365

6-24V CIRCUIT TESTER



- Bronze body housing
- Cover cap for contact needle
- 24V/3W interchangeable bulb
- Test voltage: 6-24V
- For application of DC circuits only
- Length: 107mm



Item Code	Bishops Code
9DC22	64560590

LAN SCOUT® JR. 2 CABLE TESTER



- Cable tester for data (RJ45) terminated cables and patch cords
- Large backlit LCD for low lit areas displays pin to pin wiremap results
- Test for Open, Short, Miswire or Split-Pair faults, Cross-over and Shield
- Intuitive user interface features three buttons with simple, easy-to-identify test responses
- Tone on single wire, wire pair or all 8 conductor wires
- Multiple style tone generator (solid/warble); requires probe (sold separately)

Features:

- Backlit LCD display
- Auto power-off
- 60cm drop protection
- Self-storing remote
- 113(h) x 64(w) x 25(d)mm
- Weight: 122g
- Includes: 2 x AAA Alkaline batteries



Item Code	Bishops Code
VDV526-200	62004326

SCOUT® PRO 3 CABLE TESTER KIT



- Cable tester tests voice (RJ11/12), data (RJ45) and video (coax F-connector) terminated cables with clearly defined results
- Measure cable length up to 2000 feet (610 m)
- Test for Open, Short, Miswire or Split-Pair faults
- Backlit LCD screen displays cable length, wiremap, cable ID and test results
- Trace cables, wire pairs and individual conductor wires with multiple style tone generator (requires analogue probe Cat. No. VDV500-123; sold separately)
- Hub blink mode to identify port location on a hub or a switch
- LanMap™ and CoaxMap™ Location Remotes (5 each) map and ID multiple cable runs in a single step
- Features voltage warning, shield detection, low battery indicator, a self-storing remote, and auto power off feature to conserve battery life

Includes:

- 1 x Scout® Pro 3 Tester
- 1 x Self-storing remote
- 5 x LanMap™ RJ45 locator remotes
- 5 x CoaxMap™ F-connector locator remotes
- 2 x Coax F-connector
- Manual
- 9V Battery



Item Code	Bishops Code
VDV501-851	62004322



VOLTAGE TESTERS & MULTIMETERS

GENERAL INDUSTRIAL PRODUCTS

VOLTAGE TESTER

- Suitable for voltage testing in cars and automobiles
- DC electrical systems
- 6 – 24V



Item Code	Bishops Code
6245	64560520

VOLTAGE TESTER PEN

- Non-contact detection of AC voltage
- Audible and visual voltage indicators
- Automatic power-off feature
- Lightweight durable construction with a convenient pocket clip
- CAT IV 1,000V safety rating
- Dual range
- 12-1,000V/48-1,000V



Item Code	Bishops Code
A-NCVT-2	62004328

NON-CONTACT 1,000V VOLTAGE TESTER

- Voltage AC range: 80–1,000V (50/60Hz)
- Adjustable sensitivity
- Locate electrical voltages in cables and plugs
- Find line breaks in wires and cables
- Power off with knob
- Low voltage (L): red light
- High voltage (H): green light
- Includes: 2 x AAA 1.5V batteries
- Standard category: EN 61000-6-3 EN 61000-6-1 CAT III



Item Code	Bishops Code
6CB31US	62004329

ELECTRONIC AC/DC VOLTAGE TESTER

- For AC/DC voltage from 12-600V at nine useful levels aligned with commonly used voltages
- Uses standard replaceable multimeter test leads for versatility
- CAT IV 600V modern solid-state design for safety
- Easy to use bright LED display clearly reports the voltage present in the circuit being tested
- Integrated test-lead holders are used for lead storage or for holding the probes correctly spaced for insertion into tamper-resistant US-style outlets
- Inherent low input impedance reduces the possibility of falsely reading ghost or stray voltages on non-energised circuits
- Batteries not required, as tester is powered by the applied voltage in the circuit being tested



Item Code	Bishops Code
ET60	64530825

ANALOGUE MULTIMETER

- Shockproof up to 1m height
- Can determine the capacity of both manganese and alkaline batteries
- Battery check function
- LI:150µ/15m/150mA
- Weight including battery: 300g



MEASUREMENT	
Current DC Range	0.25–500mA
Voltage AC Range	10–1,000V ±(5.0%f.s)
Voltage DC Range	0.25–1,000V ±(5.0%f.s)
Resistance	x1/x10/x1KΩ ±(5.0% arc)
Temperature Range	0–40°C
Bishops Code	64530020

SPARE MULTIMETER LEADS

- PVC insulation coating
- 1,000V
- Length: 900mm
- Red and black
- Includes:**
- 1 x Test pin
- 2 x Jack connectors



Length	Bishops Code
900mm	64530990

600V POCKET SIZE DIGITAL MULTIMETER

- Pocket size with flip cover design
- Auto range, auto power-off selection
- Continuity check, diode test, overload and low battery indicators
- Approx. 4,300 count LCD display
- Easy operation and low power consumption
- Attachable test leads
- Voltage AC/DC range: 0.1mV - 600V
- Resistance: 0.1Ω - 40MΩ
- Sampling rate: 2 times/sec



Item Code	Bishops Code
9DM1381	64530315

600V DIGITAL MULTIMETER

- Date hold, auto range, auto power-off option
- Continuity check, diode test, Hfe (NPN, PNP), LED check, low battery indicator
- Unit and function indication
- 1,999 count LCD display
- Negative polarity indicator
- Fuse with: 500mA/660V & 10A/600V
- Voltage AC/DC range: 0.1mV - 600V
- Current AC/DC range: 0.1µA - 10A
- Resistance: 0.1Ω - 20MΩ
- Sampling rate: 3 times/sec



Item Code	Bishops Code
9DM1361	64530095



DIGITAL MULTIMETERS

- Large LCD display
- Audible continuity and diode test
- Low battery protection
- Auto power-off
- Max. display: 1999
- Accepts one 9V battery
- Temperature range: -40–1,000°C

Includes:

- 1 x test leads
- 1 x instruction manual
- 1 x battery



	STANDARD	PROFESSIONAL
MEASUREMENT		
Current AC Range	2mA–20amp ±(0.8%+1)	200mA–20amp ±(1.8%+3dgt)
Current DC Range	200µA–20amp ±(0.8%+1)	20mA–20amp ±(0.8%+1dgt)
Voltage AC Range	2–750V ±(0.8%+3)	20–750V ±(0.8%+3dgt)
Voltage DC Range	200mV–1,000V ±(0.5%+1)	200mV–1,000V ±(0.5%+1dgt)
Resistance	200Ω–20MΩ ±(0.8%+1)	200Ω–200MΩ±(0.8%+1)
Frequency	2–200kHz	2–20kHz
LCD Display	27 x 60mm	67.5 x 43mm
SPECIFICATIONS		
Dimensions	165(l) x 85(w) x 32(d)mm	186(l) x 86(w) x 33(d)mm
Weight	300g	500g
Colour	Black	Orange
Bishops Code	64530030	64530040

FLUKE DIGITAL MULTIMETER COMBO KIT

- Large backlit digital display
- Magnetic hanger to go hands-free

Includes:

- Fluke 3000 FC True-rms digital multimeter with backlight
- Fluke TL910 electronic test probes
- Fluke TL224 silicone test leads
- Fluke AC280 heavy duty hook clips
- Fluke C35 lightweight soft carrying case
- ToolPak™ magnetic meter hanger
- Installed batteries
- User's manual CD



Item Code	Bishops Code
FLUFLK3000FC/EDA2	64530320

PROFESSIONAL SERIES METERS

- Solid construction and rugged rubber boots
- Data hold feature saves measurement for later viewing
- Bar graph responds quickly to changes in measurement
- Max/min/relative reading for quick troubleshooting in the field
- Large backlit display
- Lead storage protects leads



Item Code	MM450 Electrician's/HVAC Multimeter	MM720 Electrician's/HVAC TRMS Multimeter
MEASUREMENT		
AC Current	10A	10A
DC Current	10A	10A
AC Voltage	600V	1,000V
DC Voltage	600V	1,000V
Resistance	50MΩ	60MΩ
Capacitance	400µF	4,000µF
Frequency/Duty Cycle	1Hz–50kHz	1Hz–500kHz
Temperature	-40–1,000°C	-40–1,000°C
Diode Test	✓	✓
Audible Continuity	✓	✓
FEATURES		
LCD Counts	4,000	6,000
Data Hold	✓	✓
Range Hold	✓	✓
Auto Ranging	✓	✓
Auto Power-Off	✓	✓
Backlight	✓	✓
Maximum/Minimum Hold	✓	✓
Magnetic Hanger Compatible	✓	✓
True RMS	✓	✓
Low Impedance	–	✓
SPECIFICATIONS		
CAT Rating	CAT III 1,000V	CAT IV 600V, CAT III 1,000V
Batteries	2 x AAA	2 x AAA
Length	165mm	176mm
Width	80mm	85mm
Depth	28mm	47mm
Weight	258g	345g
Included Accessories	Test Leads, Batteries, Thermocouple & Case	Test Leads, Batteries, Thermocouple & Case
Bishops Code	64530075	64530085

GET MORE AT BISHOPS ▶



FIRST AID KITS
Page 34



INSULATED PLIERS
Page 202



CLAMP METERS

PROFESSIONAL SERIES CLAMP METERS

- Large jaw sizes
- Worklights illuminate dark work spaces
- Data hold captures measurements in any situation
- Built-in magnetic mount for hands-free convenience
- Non-contact voltage detection at the push of a button
- Quick-response bar graph shows elusive fluctuations



Item Code	A-CL320	A-CL600	A-CL700	A-CL800	A-CL900
MEASUREMENT					
AC Current	400A	600A	600A	600A	2,000A
DC Current	-	-	-	600A	2,000A
AC Voltage	600V	1,000V	1,000V	1,000V	1,000V
DC Voltage	600V	1,000V	1,000V	1,000V	1,000V
Resistance	40MΩ	40MΩ	60MΩ	60MΩ	60MΩ
Capacitance	4,000μF	-	6,000μF	6,000μF	6,000μF
Frequency/ Duty Cycle	10Hz-1MHz	-	1Hz-500kHz	1Hz-500kHz	1Hz-500kHz
Temperature	-40-1,000°C	-	-26-538°C	-26-538°C	-
Diode Test	✓	✓	✓	✓	✓
Audible Continuity	✓	✓	✓	✓	✓
Non-Contact Voltage	✓	✓	✓	✓	✓
FEATURES					
LCD Counts	4,000	4,000	6,000	6,000	6,000
Data Hold	✓	✓	✓	✓	✓
Auto Power-Off	✓	✓	✓	✓	✓
Backlight	✓	✓	✓	✓	✓
Worklight	✓	✓	✓	✓	✓
Auto/Manual Range	✓	✓	✓	✓	✓
Maximum Hold	✓	✓	✓	✓	✓
Minimum Hold	✓	✓	✓	✓	✓
Bar Graph	✓	✓	✓	✓	✓
True RMS	✓	✓	✓	✓	✓
SPECIFICATIONS					
CAT Rating	CAT III 600V	CAT III 600V	CAT IV 600V	CAT IV 600V	CAT IV 600V
Batteries	3 x AAA	2 x AAA	2 x AAA	2 x AAA	2 x AAA
Jaw Size	41mm	31.8mm	35mm	35mm	50mm
Length	215mm	225mm	231mm	231mm	264mm
Width	89mm	85.7mm	97mm	97mm	99mm
Depth	38mm	38.1mm	39mm	39mm	43mm
Weight	314g	303g	335g	354g	499g
Included Accessories	Test Leads, Batteries, Thermocouple & Case	Test Leads, Batteries & Case	Test Leads, Batteries, Thermocouple & Case	Test Leads, Batteries, Thermocouple & Case	Test Leads, Batteries & Case
Bishops Code	64530360	64530375	64530365	64530380	64530385

CLAMP METER

- Measures AC/DC current
- VFD low pass filter to accurately measure non-linear signals
- Remotely log, trend and monitor
- Filters out noise and captures starting current



Item Code	Bishops Code
FLU376FC	64530340

600A DIGITAL CLAMP METER



- Unit and function indication, auto power-off selection, overload and low battery indicators
- 1,999 Count LCD display
- Continuity check, diode test and negative polarity indicator
- Attachable test leads
- CE Approval IEC 61010-1, IEC 61010-2-032, 600V CAT.III Pollution Degree 2
- Max. clamp size: Ø30mm
- Current AC range: 0.1 – 600A
- Voltage AC/DC range: 0.1mV – 600V
- Resistance: 0.1Ω – 20MΩ
- Sampling rate: 3 times/sec



Item Code	Bishops Code
9DM2351	64530352

CLAMP TESTER MULTIMETER

- LCD display, 3½ digits
 - Low battery indication
 - Data hold and overload protection
 - Large jaws can measure conductor with diameter up to 60mm
 - Insulation test: 20M/2,000MΩ ± (2.0%rdg+2dgts)
- Includes:**
- 1 x test leads



MEASUREMENT	
Current AC Range	200-1,000A ±(2.0%rdg+5dgts)
Voltage AC Range	200-750V ±(1.0%rdg+4dgts)
Voltage DC Range	200m-1,000V ±(8%rdg+4dgts)
Resistance	200/20KΩ ±(1%rdg+2dgts)
SPECIFICATIONS	
Dimensions	237(l) x 95(w) x 40(h)mm
Weight	310g
Bishops Code	64530220

GENERAL INDUSTRIAL PRODUCTS

GET MORE AT BISHOPS



SAFETY GLASSES

Page 13

LOST IN THE DARK?

Let us shine some light on it with the following torch guide.

Style

Pen/Pocket Torches are similar to hand held torches, but a smaller scale. They are designed to be convenient and portable, providing light for inspection purposes.

Hand Held Torches are extremely versatile and useful in situations where light needs to be projected in a certain direction. They come in a variety of styles and sizes such as standard, large and lantern.

Head Torches strap to the head or over a helmet, to provide 'hands free' pinpointed lighting. Head torches typically have multiple modes providing different lights suitable for different applications.

Work Lights are typically in the shape of a bar or spotlight. They are mountable and often include either a hook, magnet for metal surfaces or both. Designed to withstand drops and harsh workshop environments.

Brightness Modes – torches can come with different brightness modes – low, medium or high. Some models are dimmable.

Vision Modes – torches can also have multiple vision modes, including spot, flood, red light (night vision) and green light (inspection) amongst others.



Battery

Typically the larger the battery, the increased brightness and run time of the torch. Most torches require AAA to D sized batteries. Whatever battery you need, you can be sure Bishops can source it for you. Find our catalogue range on page 382 or just give us a call.

Rechargeable Batteries are more environmentally friendly and cost effective over time. The downside is that most rechargeable batteries do not hold the same amount of energy as a single use variety.

Bulb

Incandescent bulbs only provide 750 to 1,000 hours of light before the filament is worn out.

Halogen bulbs use halogen gas to make the globe last longer.

Xenon globes are the most efficient of the standard bulbs and produce more light than traditional globes.

LED lights are more efficient than standard bulbs, giving them a longer life (up to 100,000 hours). They produce a brighter white light and can also be coloured.



Power/Lumens

Lumens refer to how intense the light created by the torch is on the highest setting, with fresh batteries. The higher the lumens, the more intense the light.

HEAD LAMP

- 3 x LED bulbs
- 1 x Krypton bulb
- Fitted with adjustable stretch-fabric head straps
- Suits hiking, cycling and working
- Varies between short and long distance light
- 80 hours burn time

Includes:
• 3 x AAA batteries



Item Code	Bishops Code
ZF6543-3AAA	86660410

HIGH POWER HEAD LAMP

- 1 x Cree LED bulb
- Fitted with adjustable stretch-fabric head straps
- 10m visible distance
- 4.5V
- 100,000 hours LED life
- 4 hours burn time

Includes:
• 3 x AAA batteries



Item Code	Bishops Code
E57	86660415

LED HEAD LAMP

- Brightness modes: high, low
- Provides hands-free light where you need it, when you need it
- Safety Certified (IECEX)
- Includes: 3 x AAA batteries
- Lumens: 74
- Run time: 11hrs



Item Code	Bishops Code
60014955	86660019

LED PEN TORCH

- Convenient to carry in your pocket or tool box
- 360° rotation for precise positioning
- Magnet included on clip
- IP54 Waterproof
- Requires: 3 x AAA batteries (sold separately)
- Lumens: 230



Item Code	Bishops Code
79832	86660230

MINI ALUMINIUM TORCH

- 9 x LED bulbs
- 24 hour battery life
- 5m visible distance
- Comes with wrist loop for more secure carrying
- Size: 27 x 85mm
- Weight: 65g

Includes:

- 3 x AAA batteries



Item Code	Bishops Code
	86660220

ALUMINIUM TORCH

- 10 x LED bulbs
- Weatherproof
- Two-mode operation for 3 or 10 bulbs
- Varies between spotlight and floodlight
- Size: 39 x 39 x 160mm

Includes:

- 4 x AA batteries



Item Code	Bishops Code
ZF7642-1	86660320

ALUMINIUM TORCH

- 3 x Cree LED bulbs
- Comes with wrist loop for more secure carrying
- Tough aluminium body
- Waterproof and shockproof
- 30m light distance
- 2½ hours max. run time
- LED lifetime of up to 100,000 hours
- Size: 45 x 35 x 130mm

Includes:

- 3 x AAA batteries



Item Code	Bishops Code
ZF7436-B	86660245

RECHARGEABLE TORCH

- 3 x Cree LED bulbs
- Water resistant
- 25 lumens
- 6 hours burn time
- 2.5 hours discharge time

Includes:

- 2 x rechargeable C cell batteries
- 1 x charger for the car/vehicle
- 1 x 240V AC charger



Item Code	Bishops Code
ZF7458-1	86660506

ALUMINIUM TORCH

- Heavy duty aluminium
- Weatherproof
- Fitted with Krypton bulb
- Varies between spotlight and floodlight
- Suitable for domestic and industrial use
- 55mm head size
- Size: 260 x 42mm
- Accepts 3 x D batteries
- Batteries not included



Item Code	Bishops Code
ZF7641	86660260

MINI FLASHLIGHT WITH FLEXIBLE HEAD

- 1 x uLa-bright LED bulb
- Bulb has a lifetime of 80,000 hours
- Short distance light
- 100mm with flexible arm
- Accepts 2 x AA Batteries



Item Code	Bishops Code
ZF2804	86660360

ALUMINIUM TORCH

- 1 x Xenon bulb
- 3 x LED bulbs
- LED bulbs have a lifetime of over 80,000 hours
- Waterproof and shockproof
- Adjustable focus
- Comes with wrist loop for more secure carrying

Includes:

- 3 x AAA batteries



Item Code	Bishops Code
ZF7644-1	86660310

6V INDUSTRIAL LANTERN

- Waterproof
- Floating
- Durable
- Requires 1 x 6V lantern battery (not included)
- Non-slip grip
- 146m beam distance
- 67 lumens
- 8 hours run-time (with Eveready Super Heavy Duty 6V battery)
- Size: 150 x 225 x 140mm



Item Code	Bishops Code
35000790	86660020

LED POCKET WORK LIGHT

- Compact pocket size
- 360° rotatable magnetic base
- COB LED main light and SMD LED top light
- 80 CRI, 6,500K
- 3.7V 2600mAh Li-ion battery
- Lumens: 120-200 (COB LED), 60 (SMD LED)
- Run time: 5/2hrs (normal), 3hrs (high)
- Charging time: 2.5hrs
- IP54 and IK07 rating



Item Code

20033

SPECIAL ORDER: PLEASE QUOTE ITEM CODE UPON ORDERING THIS PRODUCT

SEE EZY RECHARGEABLE LED POCKET INSPECTION LIGHT

- Features 8 0.5W SMD LED lights
- Provides super bright white light
- Rechargeable Li-Ion battery
- 5 hours of continuous use



Item Code

71303

Bishops Code

30221048

LED CORDLESS WORKSHOP LIGHT WITH GAS DETECTION FEATURE

- UV top light for gas leak detection
- 180° adjustable handle
- Three strong magnets and two foldaway hanging hooks
- 4W COB LED main light and 3W SMD LED top light
- 80 CRI, 6,500K
- 3.7V, 2,200mAh Li-ion battery
- Lumens: 400 (COB LED), 100 (SMD LED)
- Run time: 3hrs (normal), 10hrs (top light), 28hrs (top UV light)
- Charging time: 3.5hrs
- IP54 rating



Item Code

20066N2

Bishops Code

86660512

SEE EZY RECHARGEABLE LED INSPECTION LIGHT

- Features 48 powerful LEDs providing 8 hours of continuous illumination
- Supplied with a 12/24V DC charger and 240V AC docking station for convenient recharging and storage when not in use
- The charger can be desk or wall mounted, making it ideal for all workshop environments
- No fade out when the battery is low
- The durable rubberised housing is shock and weather resistant with an integrated Off/On switch, hanging hook and a shatterproof polycarbonate lens
- Low battery indicator
- Lithium battery with no memory effect
- Integrated magnet
- Fold away metal swivel hook



Item Code

71320

Bishops Code

30221055

LED SLIM INSPECTION LIGHT

- Slimline design to reach tight and restricted spaces
- 360° rotatable magnetic base
- Stepless dimming switch
- 7W COB and 3W SMD LED lights
- 80 CRI, 6,500K
- 3.7V 2,600mAh Li-ion battery
- Lumens: 60-700 (COB LED), 120 (SMD LED)
- Run time: 16/1.5hrs (normal), 9.5hrs (top light)
- Charging time: 4hrs
- IP54 and IK07 rating



Item Code

20088

SPECIAL ORDER: PLEASE QUOTE ITEM CODE UPON ORDERING THIS PRODUCT

SEE EZY COMPACT RECHARGEABLE LED INSPECTION LIGHT

- Features 15 high intensity LEDs
- 4 hours of continuous operation at 450 Lumens peak output
- A compact cordless unit ideal for on-the-job requirements and small enough for tool or glove box storage
- The durable weatherproof body features a shatterproof polycarbonate lens, and convenient integral belt clip
- Includes off/on switch
- Comes with a 240V AC charger and 12V DC charger
- Rechargeable NiMH battery with no memory effect



Item Code

71302

Bishops Code

30221050

SLIM INSPECTION WORKLIGHT



- Brightness modes: high, low
- 11mm thickness adjustable light 15W COB LED
- Magnetic swivel base with functional hook
- IP54 waterproof
- Rechargeable battery: 3.7V - 2,200mAh Li-ion
- 100/240V AC adaptor
- 5V/1,000mA USB charger
- Charger time: 3.5-4.0hrs
- Run time: 5hrs (normal), 2.5hrs (boost)
- Lumens: 410
- Length: 340mm



Item Code

9TA26D

Bishops Code

86660515

LED TORCH & WORKLIGHT KIT

- Waterproof
- Cree LED bulbs
- Features slim worklight and compact flashlight
- Magnetic bottom
- Lumens: 250 (torch), 300 (worklight)
- Run time: 3hrs
- Beam distance: 150m (torch), 50m (worklight)



Item Code

F7519

Bishops Code

86660265



WORK & FLOOD LIGHTS

GENERAL INDUSTRIAL PRODUCTS

LED WORK LIGHT

- Long life high intensity LEDs
- Shock resistant body and impact resistant polycarbonate tube
- Low heat output
- 5m PVC cable
- Handy hanging hook
- 1m impact drop protection
- Effective range: 3m
- Lumens: 500



Item Code	Bishops Code
K1047	62042144

PORTABLE LED RECHARGEABLE FLOODLIGHT

- AC-DC/12V charger
- Effective range: 5m
- Run time: 3-4hrs
- Lumens: 500
- Weight: 1kg



Item Code	Bishops Code
K1120	66512505

PORTABLE LED ELECTRIC FLOODLIGHTS

- Uses SMD LED light technology
- 240V
- Aluminium die cast body
- IP65 rated
- 120° illumination coverage
- Cable length: 3m



Item Code	Wattage	Lumens	Bishops Code
K1527H	20W	1,700	66512530
K1528H	30W	2,600	66512534
K1529H	50W	4,300	66512538

2 HEAD LED ELECTRIC FLOODLIGHT WITH TRIPOD

- 2 x 50W SMD LED lamps
- 240V
- Aluminium die cast housing
- Tempered glass
- IP65 rated
- Effective range: 20m
- Lumens: 4,300 x 2
- Includes 3m cable



Item Code	Bishops Code
K1529T	66512626

TWIN HALOGEN LAMP

- 2 x 500W halogen lamps
- 240V
- Adjustable telescopic tripod (range 0.7-1.5m)
- Protection class: IP44
- Lamps pivot 90° and rotate 270°
- Weight: 7kg
- 3m cable
- 2 x 6,000 lumens bulbs included



Wattage	Bishops Code
500W	66512620

DIFFERENTIATE LIGHT GLOBES

Globes – a very common source of light that are fitted almost everywhere we go. These small objects provide light in the darkest places, but they aren't all the same. Let's explore some of the different types of globes that you will find at Bishops.

Light Emitting Diodes (LED) lights are becoming one of the most commonly used lights due to their high efficiency and life time. You will find these in a large number of applications from torches to driving lights.

Fluorescent lights are often used in workplaces or warehouses where a large area is required to be lit. They provide high efficiency with good illumination.

Halogen lights often glow white and are used for clear visibility applications. You will often find these types of lights in your vehicle headlights or even in your home reading lights.

Mercury lights are more efficient than most fluorescent lights and are also used to light up large areas. Their blueish-green tint makes them unsuitable for retail use. You will most often find these lights in street lamps, warehouses and even big sports stadiums.



GET MORE AT BISHOPS



HAZARD LIGHTS

Page 58

AUTOMOTIVE REFLECTORS

- Self-adhesive reflective panels
- Dimensions: 70(l) x 30(w) x 6(d)mm



Item Code	Colour	Bishops Code
LS9197	Amber	30250400
LS9198	White	30250405
LS9199	Red	30250410

27W LED WORK LAMP

- 9–36V
- Flood beam
- 9 High intensity Cree LEDs
- Temperature range: -40°C to 60°C
- IP68 and IP69K rated
- Dimensions: 133(w) x 224(h) x 75(d)mm



Item Code	Bishops Code
IWL9327F	30250050

27W FLOOD BEAM WORK LAMP

- 10–30V
- 9 x Epistar high intensity LEDs
- Single bolt mount
- Black powder coated die-cast aluminium housing
- Lumens: 1,800
- IP67 Rated
- Dimensions: 110(w) x 128(h) x 55(d)mm



Dimensions	Bishops Code
IWL3601SF	30250070

LED FLOOD BEAM WORK LAMPS

- High intensity LEDs
- Single bolt mount
- Black powder coated die-cast aluminium housing
- IP67 Rated



Description	Voltage	Lumens	No. of LEDs	Dimensions	Bishops Code
36W Round	9–36V	3,600	36	110(w) x 47(d) x 132(h)mm	30250055
27W Square	10–30V	1,800	9	110(w) x 27.5(d) x 128(h)mm	30250075
27W Square	10–30V	1,800	9	110(w) x 27.5(d) x 128(h)mm	30250080



AUTOMOTIVE LIGHTS

GENERAL INDUSTRIAL PRODUCTS

LED DRIVING LIGHTS

- 10–30V multi-volt input
- 16 x 5W high intensity Cree LEDs
- Die cast aluminium housing with anti-vibration mount
- Polycarbonate lens
- Combination flood/spot beam pattern
- 6,000K colour rating
- Face diameter: 7"
- Lumens: 7,200



Item Code	Description	Bishops Code
03.LDL165RC	Driving Lights – Pair	30250100
03.LDL165CC	Replacement Clear Covers – 2 Pack	30250225

40W DRIVING FLOOD BEAM

- 9–36V
- 30°
- 4 LEDs
- 3,400 Effective lumens
- IP68 Rated
- Dimensions: 190(w) x 83(h) x 60(d)mm
- Weight: 885g



Item Code	Bishops Code
ILB190FB	30250105

40W DRIVING LIGHTBAR

- 9–36V
- 10°
- 4 x LEDs
- 3,600 lumens
- IP68 Rated
- Dimensions: 190(w) x 83(h) x 60(d)mm
- Weight: 885g



Item Code	Bishops Code
ILB190SB	30250110

80W DRIVING FLOODLIGHT

- 9–36V
- High intensity LEDs
- Combined spot (pencil) and flood (spread) beam patterns
- 15°, 35°
- IP68 Rated



Item Code	Description	Watts	Effective Lumens	Weight	Bishops Code
ILB510CB	450 Single Row LED	120	10,200	2.14kg	30250115
ILB670CB	600 Single Row LED	160	13,600	2.78kg	30250120

LICENCE PLATE LED LAMP

- 9–33V



Item Code	Bishops Code
LS9093	30250305

LED COMBINATION REAR LAMPS

- 9–33V
- 12 x high intensity LEDs in each stop
- Dimensions: 284(w) x 100(h) x 37(d)mm
- IP67 Rated



Item Code	Description	Bishops Code
LS9016	Stop/Tail/Indicator Light	30250250
LS9017	Stop/Tail/Indicator/Reverse Light	30250255

LED COMBINATION REAR LAMPS

- 9–33V
- Dimensions: 222(w) x 96(h) x 34(d)mm
- IP67 Rated



Item Code	Description	LEDs	Bishops Code
LS9048	Stop/Tail/Indicator	12 x High Intensity	30250280
ISL400RAW	Stop/Tail/Indicator/Reverse	12 x Red & 8 x Amber High Intensity	30250285

LED REAR LAMPS

- 9–33V
- 16 x high intensity LEDs
- Dimensions: 177(w) x 100(h) x 31(d)mm
- IP67 Rated



Item Code	Description	Bishops Code
LS9060	Stop/Tail	30250265
LS9061	Rear Direction Indicator	30250270
LS9062	Reverse	30250275

ZEON LED REAR COMBINATION LAMPS

- 10-30V
- IP67 Rated



Item Code	Description	Dimensions	Bishops Code
ISL500RAW	Stop/Tail/Sequential Indicator/Reverse	290(w) x 110(h) x 40(d)mm	30250290
ISL700RA	Stop/Tail/Sequential Indicator	370(w) x 128(h) x 46(d)mm	30250295
ISL300RAW	Stop/Tail/Indicator/Reverse	595(w) x 131(h) x 46(d)mm	30250300

UNIVERSAL LED COMBINATION FRONT LAMP

- Front indicator and position light for bull bar
- 10-30V
- 15 high intensity LEDs in each stop
- Dimensions: 226(w) x 57(h) x 45(d)mm
- IP67 Rated



Item Code	Bishops Code
LS9031	30250260

AUTOMOTIVE HALOGEN GLOBES

- Replacement globes for car and truck headlights
- ADR H1



Item Code	Description	Suits	Bishops Code
GL2100	12V, 55W	Car Headlights	66512680
GL2105	24V, 70W	Truck Lights	66512682

17 PIECE AUTOMOTIVE BULB GRAB KIT

- Comes in hard plastic case for handy storage
- Includes:
 - 10 Sizes – 53 x 3 to 2057 x 2



Item Code	Bishops Code
FD-6159	40420075

BULL BAR MOUNTING BRACKETS

- Suitable for driving lamps, lightbars and worklamps
- Mounts lights on bull bars or round tube
- Black anodised polyester powder coated 6063 extruded aluminium
- Supplied with stainless steel 8mm threaded bolt, nut and washer
- Rubber sleeve provided to remove any damage to bull bar



Item Code	Size Diameter	Bishops Code
IBB50MM	50mm	30250200
IBB64MM	64mm	30250205
IBB76MM	76mm	30250210

HU9757 MINEBAR FITTING KIT

- Allows fitment of HULK 4x4 Minebars Direct To Vehicle
- Suits Toyota Landcruiser 70 Series 1999 - current



Item Code	Bishops Code
HU9757	30250525

DRIVING LIGHT WIRING HARNESS

- 12V wiring harnesses
- Suit driving lights and lightbars



Item Code	Description	Bishops Code
IWH001	Driving Light & Lightbar Wiring Harness	30250150
DLWIREKIT12V	Driving Light Wiring Harness	30250165

HEADLIGHT ADAPTOR KITS

- Suits driving lights and lightbars



Item Code	Description	Bishops Code
IWH005	H4 Headlight Adaptor Kit	30250155
IWH008	H7 Headlight Adaptor Kit	30250160

FIXED REVERSING ALARM

- Compact reversing alarm
- Dual voltage and good sound level performance make this unit suitable for a wide range of applications
- Ideal for trucks, buses, and smaller construction or industrial equipment
- 12/24V
- 97dBA
- Dimensions: 102(l) x 41(d) x 67(h)mm



Item Code	Bishops Code
HO2001	66512660

REVERSING ALARM

- Offers high sound level performance and is ideal for use in quarry or mine applications
- Manually adjustable fingertip control
- 12/24V
- 87-107dBA
- Dimensions: 137(l) x 92(d) x 121(h)mm



Item Code	Bishops Code
HO2002	66512665

TWIN CORE TRAILER CABLE

- Suitable for wiring trailers
- Black PVC sheath
- Twin core red and black colours
- 3mm
- Strand no./size: 14/0.32
- Roll length: 30m



Item Code	Bishops Code
CW2301	30220800

7-CORE TRAILER CABLE

- Suitable for wiring trailers and caravans
- Black PVC sheath
- 4mm (15A) single core x 7
- 7 core colours (white, yellow, brown, red, green, black, blue)
- Strand no./size: 23/0.32
- Roll length: 30m



Item Code	Bishops Code
CW3471	30220850

LOAD RESISTORS

- 21W simulated
- 50W total
- 2 per pack



30220600

Item Code	Voltage	Resistance	Bishops Code
LR0012	12V	6 Ohms	30220600
LR0024	24V	24 Ohms	30220605

MINI RELAY RESISTORS

- Protects automotive components from voltage spikes
- Normally open type



Item Code	Description	Bishops Code
PR8003	12V 40A 5 Pin Resistor	30220610
PR8004	24V 40A 4 Pin Resistor	30220615
PR8005	12V 70A 4 Pin Resistor	30220620
PR8006	24V 70A 4 Pin Resistor	30220625

MICRO RELAY

- Normally open resistor type
- 4 pin

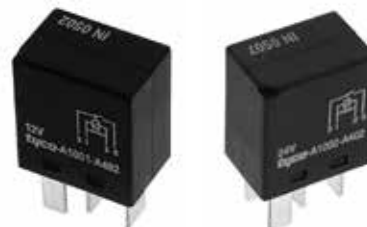

Item Code	Description	Bishops Code
PR8009	12V, 20A	30220640
PR8010	24V, 15A	30220645

CHANGE OVER MINI RELAY

- Normally open resistor type
- 30/40A
- 5 pin



Item Code	Voltage	Bishops Code
PR8007	2V	30220630
PR8008	24V	30220635

120 PIECE FUSE GRAB KITS

- Comes in hard plastic case for handy storage
- All kits include a range of 6 sizes from 5A to 30A



40420061

Description	Bishops Code
Car Fuse Kit – Includes 5A, 10A, 15A, 20A, 25A & 30A	40420061
Mini Car Fuse Kit – Includes 5A, 10A, 15A, 20A, 25A & 30A	40420065
Glass Fuse Kit – Includes 5A, 8A, 16A, 20A, 25A & 30A	40420068

CABLE LUGS



Size	Bishops Code	Size	Bishops Code
16mm ² x 10mm	71230116	50mm ² x 12mm	71230150
25mm ² x 10mm	71230125	70mm ² x 12mm	71230170
35mm ² x 10mm	71230135	95mm ² x 13mm	71230195

CRIMPS

- Waterproof and heat shrinkable
- Butt splice terminal type
- 10 per pack



Item Code	Colour	Bishops Code
TE5011	Red	30220700
TE5012	Blue	30220710

CRIMP KITS

- Double crimped insulated terminal assortment kits



30220750



30220755

Item Code	Description	Bishops Code
TE7000	142 Piece Kit	30220750
TE7001	230 Piece Kit	30220755

360 PIECE WIRE TERMINAL GRAB KIT

- An assortment of butt connectors, disconnects, bullets, rings and spades
 - Comes in hard plastic case for handy storage
- Includes:**
- Sizes: 10ga to 18ga



Item Code	Bishops Code
FD-6052	40420064

GROMMET KITS

- Rubber grommets



CA90

Item Code	Description	Kit Size	Bishops Code
CA90	Blanking Grommets – 8 Sizes: 8–28 mm Panel Hole	91 Pieces	40410080
CA63	Wiring Grommets – 12 Sizes: 3–23 mm Wire Hole	83 Pieces	40410060

125 PIECE GROMMET GRAB KIT

- Comes in hard plastic case for handy storage
 - Open and closed grommets
- Includes:**
- Open grommets 11 Sizes – 1/8" x 1/4" to 3/4" x 1 5/16"
 - Closed grommets 7 Sizes – 9/32" to 1"



Item Code	Bishops Code
FD-6001	40420052

NYLON CABLE GLANDS

- For indoor and outdoor use
- Provides seal on cable sheath
- Halogen free
- UV protected
- Seals available to suit 1.5, 2.5 and 4mm twin and earth TPS cable (ALCMG20 and ALCMG25 only)
- Approvals: IP68 (50m)
- Made from polyamide
- Neoprene seal
- Locknut supplied as standard
- Temperature range: -30°C to +80°C (up to 150°C intermittent)



Item Code	Cable Sealing Range	Thread Dia. x Length	Diameter Across Flats	Box Quantity
ALCMG12	3–6.5mm	M12 x 8mm	15	40
ALCMG16	5–10mm	M16 x 15mm	22	25
ALCMG20	10–14mm	M20 x 15mm	27	25
ALCMG25	11–17mm	M25 x 15mm	29	15
ALCMG32	18–25mm	M32 x 15mm	42	5
ALCMG40	22–32mm	M40 x 18mm	53	4
ALCMG50	30–38mm	M50 x 18mm	60	2
ALCMG63	34–44mm	M63 x 18mm	65	2
ALCMG75	48–55mm	M75 x 25mm	80	5

SPECIAL ORDER: PLEASE QUOTE ITEM CODE UPON ORDERING THIS PRODUCT



BATTERIES & CHARGERS

GENERAL INDUSTRIAL PRODUCTS

ALKALINE BATTERIES

- Long lasting alkaline batteries
- Suitable for everyday devices



Item Code	Description	Bishops Code
DURMN2400B2	AAA – 2 Pack	86620010
DURMN2400B4	AAA – 4 Pack	86620090
DURMN1500B4	AA – 4 Pack	86620095
DURMN1400B2	C – 2 Pack	86620100
DURMN1300B2	D – 2 Pack	86620105
DURMN1604	9V	86620110

INDUSTRIAL ALKALINE BATTERIES

- Long lasting power source
- Suitable for high powered devices



Size	Pack Qty	Bishops Code	Size	Pack Qty	Bishops Code
AAA	4	86620015	9V	1	86620070
AA	4	86620025	D	2	86620055
C	2	86620030	–	–	–

6V HEAVY DUTY BATTERY

- Heavy duty battery suitable for lantern torches
- Long lasting power source
- Non-rechargeable



Size	Bishops Code
6V	86620080

GET MORE AT BISHOPS



SCREWDRIVER SETS

From page 230

BATTERY CHARGING METHODS

Different types of batteries work differently and as such they also require different charging methods. By charging your battery correctly, you are able to prolong its life and keep it from running dry when it is needed most.

Nickel Cadmium batteries operate best when they are fully discharged before recharging. This keeps the capacity of the battery high and prevents the “memory effect” from taking place.



Lithium Based batteries operate best when they are frequently charged. This allows them to remain in peak operating condition. Frequent discharging will result in a reduced battery life.



Lead Acid batteries are able to be discharged and recharged on a regular basis without losing performance. Some of these batteries, such as the unsealed types, require maintenance to keep operating effectively.



BATTERY CHARGER



- Semi-professional charger for lead storage batteries
- Voltage and current selectors
- Ammeter
- Auto thermal overload and polarity protection
- Single phase
- 230V, 50/60Hz



78020030

Description	Voltage	Amps	Power	Dimensions	Weight	Bishops Code
Progress 14	6–12V	11amp	150W	200(l) x 260(w) x 175(h)mm	4.0kg	78020030
Progress 20	12–24V	16amp	300W	200(l) x 260(w) x 175(h)mm	7.0kg	78020040

BATTERY CHARGER

- Professional battery charger
- Best suited for large recharging plants
- Voltage and current selectors
- Ammeter
- Voltmeter
- Auto thermal overload protection
- Single phase
- 230V, 50/60Hz
- Voltage: 6–12–24V
- Dimensions: 245(l) x 250(w) x 435(h)mm



Description	Amps	Power	Weight	Bishops Code
Progress 25	22A	620W	12.8kg	78020050
Progress 35	38A	800W	18kg	78020060

AUTOSTAR 300 PORTABLE BATTERY CHARGER – 12V

- Portable battery charger and starter
- Charging current control and level ammeter
- Internal fuse protection
- Single phase
- 230V, 50/60Hz
- Voltage: 12V
- 38A, 480W
- Dimensions: 345(l) x 250(w) x 280(h)mm
- Weight: 14.4kg



Description	Bishops Code
Autostar 300	78060005

BATTERY CHARGER – 12-24V

- Professional battery charger and starter
- Two back wheels for easy transportation
- Slow/fast charging current selector
- Ammeter
- Thermal overload and internal fuse protection
- Single phase
- 230V, 50/60Hz
- Voltage: 12–24V
- 40A, 1,200W
- Dimensions: 320(l) x 487(w) x 745(h)mm
- Weight: 30.8kg



Description	Bishops Code
Sprint Car 540	78060010



12/24V BATTERY CHARGER

- 8 Stage fully automatic switchmode battery charger
- 12/24V 7.5A
- Charges all battery types with no risk of overcharging
- Maintains all battery sizes from 18Ah through to 240Ah
- Automatically diagnoses, recovers, charges and maintains batteries
- Rescues drained batteries over 2V for 12V and 16V for 24V batteries
- Power supply function; 5A at 13.6V, constant current charging, boost function
- IP65 rating and protection
- Size: 220(l) x 92(w) x 60(h) mm



Item Code	Bishops Code
HU6554	78060100

EMERGENCY LITHIUM JUMP STARTER

- Features maximum protection, safety and reliability
- Starts most vehicles up to 4.5L diesel and 7.0L petrol
- Can be used as a power bank for USB powered devices
- 1W Floodlight torch with SOS function
- 500 battery cycles
- USB powerbank capacity: 6,600mAh
- 1,200A peak 400A @ clamps
- Battery capacity: 13,500mAh
- Peak amps: 1,200A
- Clamp output: 400A
- Includes:**
 - 2.1A USB accessory port
 - Durable padded carry case
 - Micro USB charging lead
 - Premium spark-free clamps



Item Code	Bishops Code
HU6511	62040730

CAR & TRUCK JUMP STARTER – 12V

- 20 Jump starts per charge
- Charge virtually any USB device
- Ultra bright LED flashlight
- Natural convection cooling
- Operating temperature: -30°C to 50°C
- Peak current rating: 1,000A
- Lumens: 100
- IP65 housing protection
- Size: 170(l) x 81(w) x 43(h)mm
- Weight: 1kg
- Includes:**
 - GB40 Boost+ jump starter
 - 40" Micro USB cable
 - 12V USB charger
 - X Connect HD battery clamps



Item Code	Bishops Code
GB40	62040725

BATTERY LOAD TESTERS

- Portable
- Capacity: Up to 1,000CA



62004320



62004324

Item Code	Description	Load	Bishops Code
BLT100	Compact Load Tester	100A @ 12V, 50A @ 6V	62004320
BLT200	Carbon Pile Load Tester	500A @ 12V	62004324



JUMPER LEADS & AUTOMOTIVE ACCESSORIES

GENERAL INDUSTRIAL PRODUCTS

BATTERY & STARTER CABLES

- PVC sheath
- Strand no./size: 798/0.32
- Roll length: 30m

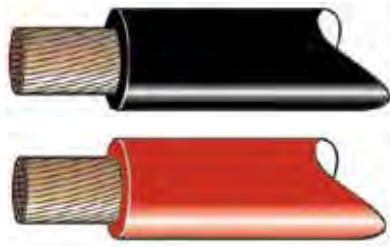

Item Code	Sheath Colour	Bishops Code
CW8003	Black	30220900
CW8004	Red	30220910

JUMPER LEADS

- Surge protection
- Ideal for the D.I.Y. individual with a small to mid-sized vehicle
- 400A
- Cable: 2.5m, 15mm²
- Steel clamp



Item Code	Bishops Code
SB400SP	62040600

HEAVY DUTY JUMPER LEADS

- Brass teeth clamps
- Surge protection
- Ideal for keeping in the workshop
- Commercial vehicles
- 750A
- Cable: 3.5m, 35mm²

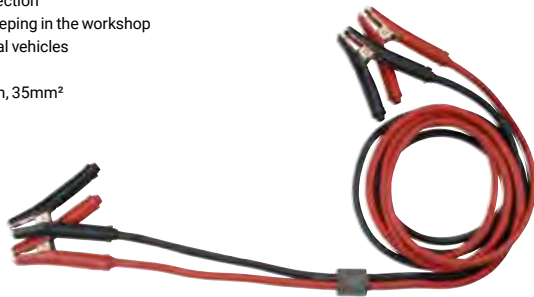

Item Code	Bishops Code
SB750SP	62040650

HEAVY DUTY NITRILE JUMPER LEADS

- Surge protection
- Solid brass teeth clamp
- Double insulated heavy duty cable offering unparalleled conductivity
- Convenient carry bag for storing cables



62040700

Item Code	Amps	Cable	Bishops Code
NB750-60SP	750A	6m/35mm ²	62040660
NB1000-45SP	1,000A	4.5m/70mm ²	62040700

BATTERY CHARGER CLAMPS

- One black and one red clamp
- To suit battery chargers
- 300A



Bishops Code
71235340

BATTERY CLAMPS

- Solid brass with insulated rubber outer casing
- Includes cable lugs and copper bridging strap
- 1,000A



Item Code	Colour	Bishops Code
BC1000B	Black	30210160
BC1000R	Red	30210162

BATTERY POST & TERMINAL WIRE BRUSH

- Removes and prevents battery corrosion
- Suits all posts and terminals



Item Code	Bishops Code
BPT12	62004110

BRASS BATTERY TERMINALS



30210012

30210010

30210018

30210016

Item Code	Description	Post	Stud	Bishops Code
BT614-P1	Wing Nut	Positive	8mm	30210010
BT614-N1	Wing Nut	Negative	8mm	30210012
BT642H-P1	Heavy Duty Bolt	Positive	10mm	30210016
BT642H-N1	Heavy Duty Bolt	Negative	10mm	30210018

BATTERY HYDROMETER

- Measures the charge level of a battery
- Calibrated graduations
- Glass tube
- User friendly



Item Code	Bishops Code
BH100	62004220

BATTERY JAR

- Water filler
- Screw top
- 2L capacity



Item Code	Bishops Code
ADX-2002A	62004400

DEMINERALISED BATTERY WATER

- Suitable for radiators, batteries and steam irons
- Highly recommended for watering indoor and delicate plants as it does not create a mineral build-up in the soil



Size	Bishops Code	Size	Bishops Code
2L	66565100	20L	66565125
5L	66565120	-	-

MANIFOLD GAUGE SET

- R134A
- Comes with hoses and couplers in a convenient carry case



Item Code	Bishops Code
TO0001	64530010

TYRE REPAIR KIT

- Repairs punctures quickly and easily
- Includes:**
 - T handle insert tool
 - Reamer
 - Rod glue
 - Strings
 - Carry case



Item Code	Bishops Code
TO9203	62090210

4WD FILTER KITS

- Filter kits to suit a range of Toyota and Ford vehicles



Suitable Car Models	Includes	Bishops Code
Toyota Hilux KUN15/16 KUN25/26 2005-11/2013	Oil, Air, Fuel & Cabin	30230005
Toyota Landcruiser HZJ70 HZJ73 HZJ75	Oil, Air & 2 x Fuel	30230025
Toyota Hilux KUN15/16, KUN25/26 12/2013 - 9/2015	Oil, Air, Fuel & Cabin	30230010
Ford Ranger PX Mazda BT50 2012-on	Oil, Air & Fuel	30250030

7 PIECE AUTO BODY REPAIR TOOL SET KING TONY

- All drop forged medium (SAE/AISI 1045,1055) carbon steel
- Hammers are hardened and tempered
- Weight: 7.5kg

Includes:

- 1 x Standard bumping hammer
- 1 x Light shrinking hammer
- 1 x Straight pick & finishing hammer
- 1 x Utility dolly
- 1 x Curved dolly
- 1 x Heel dolly
- 1 x Toe dolly



Item Code	Bishops Code
9CF-107	62050060

PORTA POWER HYDRAULIC PANEL BEATER SETS

- Heavy duty hydraulic equipment for auto body, frame repair and construction jobs
- For lifting, pushing, pulling, bending, straightening and spreading
- Automatic pump overload system helps prevent damage to ram and equipment
- Flex head features moulded rubber pad to prevent separation
- Long handles require low pumping effort
- Extension tubes snap together in seconds

Includes:

- Durable, heavy-walled extension tubes
- Comes in a tough metal carry case



62050220



62050280

Description	Capacity	Ram Lift	Min. Lift Height	Bishops Code
15 Piece Set	10t	150mm	470mm	62050280
17 Piece Set	4t	120mm	330mm	62050220



BRAKE CYLINDER HONES

- Flexible shaft
- Adjustable tension
- Replacement stones available, sold separately



Item Code	Description	Size	Bishops Code
SCMT70141	3 Arm Brake Cylinder Hone	19–64mm	62030030
SCMT70145	2 Arm Brake Cylinder Hone	13–64mm	62030040
SCMT70139	Stones To Suit SCMT70141 – 220 Grit		62030215
SCMT70138	Stones To Suit SCMT70141 – 100 Grit		62030220
SCMT70143	Stones To Suit SCMT70145 – 220 Grit		62030230

ENGINE CYLINDER HONES

- Flexible shaft
- Adjustable tension
- Replacement stones available, sold separately



Item Code	Description	Size	Bishops Code
SCMT70152	Engine Cylinder Hone	32–89mm	62030060
SCMT70136	Engine Cylinder Hone	51–178mm	62030540
SCMT70150	Stones To Suit SCMT70152 – 220 Grit		62030140
SCMT70151	Stones To Suit SCMT70152 – 400 Grit		62030120
SCMT70133	Stones To Suit SCMT70136 – 100 Grit		62030620
SCMT70134	Stones To Suit SCMT70136 – 220 Grit		62030640
SCMT70135	Stones To Suit SCMT70136 – 400 Grit		62030660

OIL PRESSURE TESTER

- For testing automotive oil pressure
- Fitted with rubber dial protector
- Includes: 1/8" NPT, 1/8" BSP & 1/4" BSP adaptors
- Range: 0–100psi (0–6.8kg/cm²)



Item Code	Bishops Code
SCMT70818	62010220

COOLING SYSTEM PRESSURE TESTER

- Attaches to radiator or header tanks
- Identifies cooling system pressure leaks
- Allows coolant to be returned to the reservoir or collected in a container for recycling
- Fits up to 45mm diameter bayonet or threaded necks
- Max. pressure: 30psi



Item Code	Bishops Code
SCMT70800	62012200

DIESEL ENGINE COMPRESSION TESTER

- Master set compression tester
- Comes with glow plug style, Cummins and C-Injector style adaptors to suit multiple vehicles
- Long reach hose and quick connect coupler
- Rubber gauge protector
- Range: 0–1,000psi



Item Code	Bishops Code
SCMT70576	62014100

COMPRESSION TESTER ADAPTOR

- Screw-in adaptor
- Deep
- Size: 14mm



Item Code	Bishops Code
SCMT70218	62080100

GET MORE AT BISHOPS



RAGS & CLOTHS

Page 403

CAR SUPPORT JACK STANDS

- Solid steel handle
- Ductile iron rack
- Self-locking
- Ratchet made out of fine cast iron milling
- Red
- Sold in pairs



62070320

Min. Height	Max. Height	Capacity (Per Stand)	Bishops Code
355mm	520mm	3t	62070320
395mm	605mm	6t	62070620

HEAVY DUTY JACK STANDS

- Made from TUV certified steel
- Features five different pin heights
- Sold individually



62070650

Min. Height	Max. Height	Capacity	Bishops Code
390mm	660mm	5t	62070650
615mm	975mm	10t	62070680

HYDRAULIC BOTTLE JACKS

- 100% factory inspection
- Heat-treated extension screw
- Serrated saddle
- Wide base
- Reinforced stress points



77030050

Min. Height	Max. Height	Capacity	Bishops Code
80mm	148mm	2t	77030020
110mm	180mm	4t	77030040
110mm	185mm	6t	77030050
115mm	190mm	8t	77030080
120mm	195mm	10t	77030100
120mm	200mm	12t	77030120
125mm	205mm	16t	77030150
130mm	217mm	20t	77030200
130mm	230mm	30t	77030300
180mm	300mm	50t	77030500

PROFESSIONAL HYDRAULIC BOTTLE JACKS

- 100% factory inspection
- Zinc-plated long handle
- Inner safety valve
- Extension screws
- Conforms to TUV/GS CE safety standards

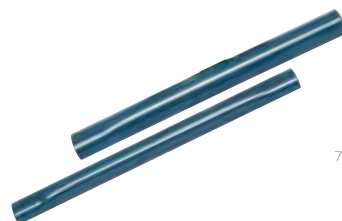

77030710



Min. Height	Max. Height	Capacity	Bishops Code
212mm	468mm	5t	77030705
220mm	483mm	10t	77030710
230mm	495mm	20t	77030720
244mm	492mm	30t	77030730

30T AIR/HYDRAULIC BOTTLE JACK

- Capacity: 30t
- Min. lift height: 9.84"
- Closed height: 5.9"



Item Code	Bishops Code
TRQ35002	77020750

GET MORE AT BISHOPS ▶

HYDRAULIC PUMPS

From Page 403





FLOOR JACKS & AUTOMOTIVE CRANES

GENERAL INDUSTRIAL PRODUCTS

AIR/HYDRAULIC FLOOR JACK

- Built-in bypass hydraulic system prevents accident overloading
- Extra long T-handle allows for easy positioning and moving
- Red



Min. Height	Max. Height	Capacity	Ram Lift	Screw Extend	Air Pressure	Bishops Code
230mm	430mm	22t	105mm	105mm	0.75–0.85MPa	77020735

COMMERCIAL FLOOR JACKS

- 100% factory tested and ANSI certified for safety
- Heavy duty steel construction
- 2 piece extended handle for efficiency
- Hydraulic pump arm
- Built-in safety overload system prevents use beyond rated load capacity
- Great for use in garages and for heavy duty industrial applications
- Low profile



77040020

Description	Min. Height	Max. Height	Capacity	Dimensions	Bishops Code
Small Chassis	92mm	440mm	2t	667(h) x 249(l) x 170(w)mm	77040010
Small Chassis	145mm	510mm	3t	700(h) x 360(l) x 290(w)mm	77040020
Small Chassis	140mm	560mm	3t	750(h) x 380(w) x 210(l)mm	77040030
Long Chassis	150mm	560mm	5t	1,570(h) x 420(l) x 290(w)mm	77040050
Long Chassis	160mm	560mm	10t	1,670(h) x 520(l) x 330(w)mm	77040100
Long Chassis	220mm	680mm	20t	1,600(h) x 350(l) x 340(w)mm	77040200

3.5T FARM STYLE JACKS

- Ratchet type jacks
- Capacity: 3.5t



Size	Bishops Code
48"	77035140
60"	77035160

2-STAGE TRANSMISSION JACK

- Smooth hydraulic lift and descent
- Foot pedal pump and release
- Four-leg design with heavy duty slide saddle
- Capacity: 500kg
- Min. lift height: 830mm
- Max. lift height: 1,935mm
- Dimensions: 740(w) x 1,750(h)mm



Item Code	Bishops Code
TEL05006	77045050

HYDRAULIC ENGINE FLOOR CRANE

- Heavy duty steel construction ensures lasting performance and durability
- Suitable for car and small truck engines
- 4-hole position boom and heavy duty 8-ton ram help provide reliable, safe functionality
- Wheels offers increased mobility
- Foldable frame stores easily



Lifting Range	Capacity	Bishops Code
0–2,355mm	0.75t	77010100
25–2,500mm	2.0t	77010200

ENGINE STAND

- Foldable engine stand
- Adjustable arms and 360° rotation
- Extra wide base for stability
- Net. weight: 33kg
- Gross weight: 35.5kg
- Capacity: 680kg
- Dimensions: 810(l) x 825(w) x 850(h)mm



Item Code	Bishops Code
T26801	77055050

4.5T ELECTRO-HYDRAULIC CAR HOIST

- Suitable for vehicle repair and maintenance
- Double-W shaped post profile for extra stability
- Double telescopic arm length
- Vehicle rear positioning
- Automatic arm locking system
- Comes with 100mm pad extension
- Lifting capacity: 4.5t
- Lifting height: 95–1,990mm
- Motor: 3kW
- Drive through width: 2.25m
- Total width (outer edges): 3.25m
- Total height: 4.00m



Item Code	Bishops Code
SM245-B	77045120

5.0T WHEEL ALIGNMENT CAR HOIST

- Electro-hydraulic operation
- Suitable for vehicle wheel alignment jobs
- Long ramps to suit a wide range of vehicles
- Suits passenger to light commercial vehicles
- Total width: 3.1m
- Total length: 5.95m

Air Jacking Beam:

- Attaches to the SM450 hoist
- Rail guide system
- Using two beams in tandem provides total 'wheel free' servicing options



77045125



77045156

Item Code	Description	Lifting Capacity	Lifting Height	Bishops Code
SM450	4 Post Car Hoist	5.0t	246–1,750mm	77045125
MICRO 3000	Air Jacking Beam	3.0t	250–511mm	77045156

2T VEHICLE RAMPS

- Vehicle tyre ramps
- Suits most standard vehicles
- Max. tyre width: 245mm
- Sold per pair



Item Code	Bishops Code
TRD2006	62070110

AUTOMATIC WHEEL BALANCER

- 6 different balancing programmes
- High precision self adhesive weight positioning
- Advanced LED numeric display screen
- Hidden spoke and weight split programme
- Handles rim diameters from 10" to 24"
- Handles rim widths from 1.5" to 20"
- Shaft size of 40mm
- External width measuring arm
- Balancing accuracy: $\pm 1.0g$
- Measuring time: 8 seconds
- Maximum wheel weight: 65kg
- Balancing speed: 200rpm
- Noise level: 70dB



Item Code	Bishops Code
AA828	77045194

MANUAL TYRE CHANGER

- Portable and convenient
- For mounting and bead breaking
- Suitable for use in the workshops or at home
- Weight: 13.5kg



Bishops Code
77045220

AUTOMOTIVE 24" TILT BACK TYRE CHANGER

- Fully automatic pneumatic tilting column
- Large 24" turntable suitable for low profile tyres
- Pneumatic locking of both vertical and horizontal distance
- Maximum rim width 14" (355mm)
- Maximum tyre diameter 39" (1,000mm)
- 12"–24" internal clamping and 10"–21" external clamping



Item Code	Bishops Code
AA221A	77045195



FLOOR CREEPERS, CHOCKS & RECOVERY TRACKS

GENERAL INDUSTRIAL PRODUCTS

METAL BASE FLOOR CREEPER

- Red metal frame fitted with a mattress and pillow for comfort while working
- Six swivel castors included
- Dimensions: 1,020(l) x 490(w) x 100(h)mm



Item Code	Bishops Code
TR6503	62016100

PLASTIC FLOOR CREEPER

- Curved strong plastic base fitted with pillow for comfort
- Six swivel castors included
- Dimensions: 935(l) x 450(w) x 110(h)mm



Item Code	Bishops Code
TRH6802	62016105

KEEP YOUR FLEET NEAT

Floors

Protect your floors from dirt, mud and general wear and tear by putting down rubber matting. Rubber matting is waterproof and easy to clean.

Seats

Plastic seat covers protect seats from accidental spills and dirty workwear. Whenever they get dirty, replace them

Car Wash & Protectant

Keep the paint job gleaming year round with car and truck wash found in the Janitorial section. Interior and exterior protectants will keep vehicles cleaner for longer and increase time between cleans, saving time and money.

Air Fresheners

Nobody likes a bad smell. Stay fresh with air fresheners or 'Little Trees'. Got a favourite scent but it is not in the catalogue? Give us a call and we will source it for you.

Tyre & Battery Cleaners

Keep the rubber on your tyres clean and free from damaging particles with a tyre cleaner. Battery cleaners also make sure your connections are always electric.

UBBER WHEEL CHOCKS



- Made from high grade rubber
- Durable and lightweight
- Suitable for cars, trucks, trailers and caravans
- Colour: black



Item	Capacity	Dimensions	Weight	Bishops Code
84060082	4t	200(l) x 100(w) x 150(h)mm	1.80kg	84060082
84060086	10t	270(l) x 155(w) x 150(h)mm	3.64kg	84060086

PU WHEEL CHOCKS & BRACKETS



- Made from high grade orange polyurethane
- Designed with the latest PU structural foam technology
- Lighter and stronger than PU chocks
- Storage brackets with mounting holes available separately for 5t and 20t chocks
- Colour: orange

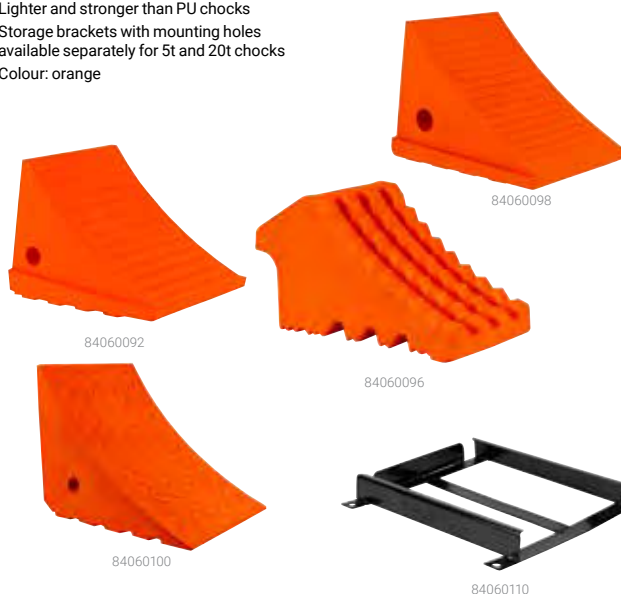

Item Code	Capacity	Dimensions	Weight	Bishops Code
POLYURETHANE WHEEL CHOCKS				
84060092	5t	210(l) x 185(w) x 160(h)mm	1.06kg	84060092
84060096	15t	235(l) x 118(w) x 130(h)mm	0.74kg	84060096
84060098	20t	290 (l) x 230(w) x 215(h)mm	2.04kg	84060098
84060100	50t	430(l) x 368(w) x 368(h)mm	6.75kg	84060100
STEEL BRACKETS				
84060110	For 5t Wheel Chock			84060110
84060114	For 20t Wheel Chock			84060114

RECOVERY TRACK



- Engineered for maximum traction in sand and mud
- Made from heavy duty rubber
- Galvanised steel cables and fittings
- Suitable for vehicles weighing up to 5t
- Compact packaging for easy storage
- Dimensions: 800(l) x 220(w)mm
- Weight: 2.4kg



Item Code	Bishops Code
84060120	84060120

TYRE PRESSURE GAUGE

- Pocket gauge with single hand



Item Code	Bishops Code
06-TC500	73665140

TYRE INFLATOR

- Premium dual hold on chuck; sealing
- Length: 150mm



Item Code	Bishops Code
06-TC530D	73665131

TYRE INFLATOR WITH GAUGE

- Heavy duty
- Dual chuck
- Imperial and metric readings
- 10–150psi/70–1,000kPa
- Overall length: 305mm
- Comes with gauge hose PEM 1000



Item Code	Bishops Code
ATG 37261	73665130

MECHANICAL TYRE INFLATOR WITH GAUGE

- Heavy duty aluminium die cast body
- Suitable for inflation and deflation
- Impact absorbing bumpers and spiral protected air hose
- Slim, ergonomic design
- Magnified sight glass
- Dual hold on chuck
- Dual scale pressure readings
- Measuring range: 0–150psi (0–1,050kPa)



Item Code	Bishops Code
51201N	

SPECIAL ORDER: PLEASE QUOTE ITEM CODE UPON ORDERING THIS PRODUCT

DIGITAL TYRE INFLATOR WITH GAUGE



- Aluminium body with oil resistant rubber casing
- Two-position lever for inflation and deflation
- Easy to read, backlit digital display powered by two CR2032 lithium batteries
- Supplied with dual chuck
- Battery life of 140 working hours
- Measuring range: 5–150psi
- Accuracy: ±1%
- Working temperature: 0 to 40°C
- Inlet: 1/4" BSP (F)



Item Code	Bishops Code
51114	

SPECIAL ORDER: PLEASE QUOTE ITEM CODE UPON ORDERING THIS PRODUCT

DIGITAL TYRE INFLATOR

- Digital gauge
- Bar readout
- Clip type nozzle
- Nozzle length: 300mm
- Max. pressure: 160psi
- Avg. air consumption: 1.41cfm @ 100psi (90psi)
- Air inlet: 1/4"
- Weight: 320g



Item Code	Bishops Code
SB-201	73665122

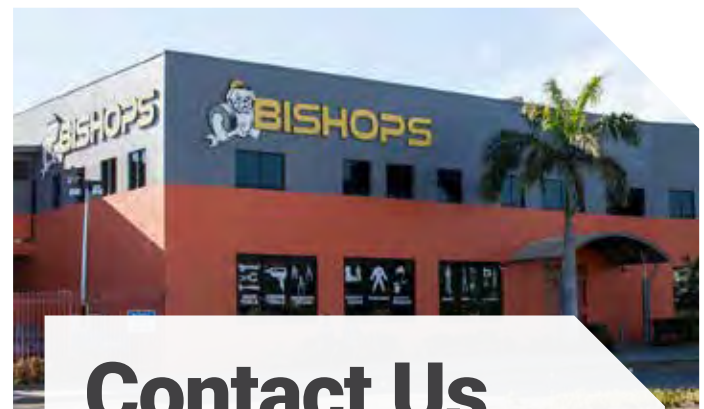

Contact Us

Opening hours for all warehouses are:

Monday to Friday: 8am–5pm
Saturday: 8am–12 noon

- | | |
|------------------------|------------------------|
| Port Moresby | Lae |
| Phone: (+675) 325 1088 | Phone: (+675) 472 3799 |
| Kimbe | Kokopo |
| Phone: (+675) 983 5500 | Phone: (+675) 982 9911 |
| Madang | Mt. Hagen |
| Phone: (+675) 422 1344 | Phone: (+675) 545 1990 |

sales@bishopbros.com.pg



TYRE & WHEEL TOOLS

GENERAL INDUSTRIAL PRODUCTS

TYRE LEVER

- Metal construction
- Designed to help pry the edge of a tyre away from the rim of the wheel it is mounted on



Description	Length	Bishops Code
Medium Duty	400mm	62090120
Heavy Duty	600mm	62090140

TRUCK TYRE LEVERS

- Used for removal (MTL1) and fitting (MTL2) of tubeless truck tyres
- Forged from tough alloy steel
- Fine tapered and ground ends eliminate damage to tyre
- Correct length for optimum leverage
- Length: 930mm

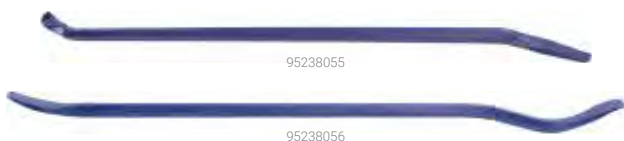

Item Code	Description	Bishops Code
5MTL1	MTL1 Straight Halte Bar – Removal Tyre Lever	62090150
5MTL2	MTL2 Curved Face Bar – Fitting Tyre Lever	62090155

TYRE LEVER

- Professional quality, forged from CR-V steel
- Straight pattern with profiled shank
- Length: 530mm
- Weight: 0.92kg



Item Code	Bishops Code
9BK41-53	62090130

BEAD BREAKER SLIDE HAMMER

- Used for breaking beads on car and truck tyres
- Made from high tensile steel with hexagon shaft for excellent control
- Well balanced heavy unit with the weight in the striker where it is needed most
- Hardened and tempered foot for durability
- Good length to minimise back strain
- Head length: 122mm
- Overall length: 1.1m
- Weight: 7kg



Item Code	Bishops Code
5BB122	62090220

TWO WAY TRUCK WHEEL WRENCH

- The prying end removes the hub caps, while the socket end removes lug nuts from the wheel
- Perfect for storing in work vehicles
- Size: 32mm(hex) x 17mm(square)



Bishops Code
62096220

WHEEL NUT WRENCH

- For most car wheel nuts in metric
- Chrome vanadium alloy steel
- Polished, chrome plated
- Suits 17, 19, 21, 22mm and ½" sockets
- Length: 400mm
- Weight: 1.7kg
- DIN 3119 ISO 6788



Item Code	Bishops Code
19911722	62096124

FOUR WAY WHEEL WRENCH

- Used for removing lug nuts from automobile wheels
- Perfect for keeping in work vehicles
- 17, 19 and 22mm sockets and ½" square drive



Bishops Code
62096120

GET MORE AT BISHOPS



TOOL BAGS & BOXES

From Page 160

MOBILE COMMERCIAL VEHICLE WASTE OIL DRAINER

- Low level commercial drainer tray
- Sturdy metal construction
- Suitable for under truck and vehicle use
- 145mm high swivel front wheels
- Internal baffles
- 860mm handle
- Dimensions: 1,098(l) x 805(w) x 240(h)mm
- Capacity: 100L



Item Code

42100

SPECIAL ORDER: PLEASE QUOTE ITEM CODE UPON ORDERING THIS PRODUCT

METAL JERRY FUEL CAN – 20L

- Complies with AS/NZS2906-2001
- Three handles on top for convenient carrying
- Spring loaded cap locking device
- Industrial strength
- BAM tested to 415kPa
- Capacity: 20L
- Green



Bishops Code

62022080

MOBILE WASTE OIL DRAINER

- Transfers and captures waste oil from crankcases, transmissions and differentials
- Reservoir oil level gauge indicates the drained oil quantity
- Drain bowl capacity: 20L
- Holding tank capacity: 80L
- Working height: 1.28-1.94m



Item Code

30080

SPECIAL ORDER: PLEASE QUOTE ITEM CODE UPON ORDERING THIS PRODUCT

PLASTICS FUEL CANS

- Features top and side handles for easier handling
- Cap has a rubber gasket for optimum sealing
- Large opening allowing for air circulation
- Flexible, vented pourer is designed to reduce 'glugging'
- Complies to standard AS2906



Description	Capacity	Dimensions	Bishops Code
Petrol – Red	5L	250(l) x 130(w) x 250(h)mm	62022070
Petrol – Red	10L	260(l) x 140(w) x 450(h)mm	62022075
Petrol – Red	20L	385(l) x 179(w) x 510(h)mm	62022078
Diesel – Yellow	20L	385(l) x 179(w) x 510(h)mm	62022085

OIL DRAINER TANK

- Collects waste oils from automotive, agricultural and machinery jobs
- Fitted with two 6" fixed-axle wheels and two 3" swivel castor wheels
- Comes with a 6.5ft discharge hose, shut-off valve, curved metal spout and sight gauge
- 19½" diameter drain bowl on a telescopic pole
- Pole length: 49"-69"
- Tank capacity: 106L/28gal



Item Code

TRG2094

Bishops Code

30208050

PLASTIC FUEL CANS

- Portable plastic fuel cans
- Built in handle
- Yellow



62022091

Item Code	Size	Bishops Code
FC5LYEL	5L	62022090
FC10LYEL	10L	62022091



FUEL & OIL CONTAINERS

GENERAL INDUSTRIAL PRODUCTS

5L PLASTIC JERRY CAN

- Colour coded for liquid identification
- Slip resistant surface
- Australian made
- Capacity: 5L
- Complies with AS2906-2001



Item Code	Bishops Code
90450125	62022092

LEVER TYPE OIL CAN

- Lever type can with deluxe brass pump
- All steel construction, seamless drawn from tin coated sheet
- Two ball valves for large volume delivery per stroke
- Suction valve has no spring, preventing malfunction due to sticking
- Supplied with both rigid steel and wire braided flexible extensions
- Premium powder coated finish
- Capacity: 500ml
- Rigid spout: 150mm
- Flexible spout: 175mm



Item Code	Bishops Code
MP23R/FB	68560100

MULTI-PURPOSE TOP UP KIT

- Ideal for topping up difficult to access oiling points in the workshop and at home
- Suitable for all oils, automatic transmission fluids, brake fluids and some hand cleaners
- Not suitable for combustible fluids
- Self-contained unit prevents oil contamination when not in use
- Capacity: 1L



Item Code	Bishops Code
7701A	68502332

PLASTIC OIL MEASURES

- Polyethylene material will not dent, scratch or corrode
- Screw on lid helps prevent contaminants entering the container and ultimately vehicle engines
- For quick and easy topping up of engines, gear boxes, diffs, transmissions and crank cases
- Flexible and rigid delivery spout options



Item Code	Description	Capacity	Bishops Code
1000MFN	Flex Spout	1L	68560132
2000MFN	Flex Spout	2L	68560134
5000MFN	Flex Spout	5L	68560136
10000MF	Rigid Spout	10L	68560138

FLEXIBLE SPOUT MEASURES



- Translucent high density polyethylene construction
- For transferring metered quantity of fluids
- Marked with both metric and imperial measurements
- Complete with flexible spout with cap and polypropylene lid



68560200

Item Code	Capacity	Bishops Code
MSR/P/F-2	2L	68560130
MSR/P/F-5	5L	68560200

PLASTIC OIL JUGS

- Polypropylene plastic pouring jugs
- Resistant to acids, bases and chemicals
- Measuring scale printed on the outside of the jug
- Sturdy handle with grip



68560121

Item Code	Capacity	Bishops Code
JUG/1000G	1L	68560121
JUG/2000G	2L	68560122
JUG/5000G	5L	68560125

GET MORE AT BISHOPS

ABSORBENT PADS

Page 38



BRAKE FLUID

Page 454



PLASTIC FUNNEL

- Heavy duty
- Polyethylene construction
- Flexible spout
- Includes filter
- Diameter: 250mm (10")



Item Code	Bishops Code
12250SFN	68530060

4 PIECE FUNNEL SET

- Includes sizes 50mm, 75mm, 100mm and 120mm



Item Code	Bishops Code
11000SFS	68530220

OIL & CHEMICAL PLASTIC FUNNEL

- Oil and chemical resistant plastic
- Suitable for general purpose use
- Ideal for industrial and domestic applications
- Size: 100mm



Item Code	Bishops Code
90450156	68530010

OIL & FUEL PLASTIC FUNNEL

- Oil and fuel resistant plastic
- Extra large mouth
- Filter screen to catch particles and grit
- Capacity: 4.7L



Item Code	Bishops Code
FNL/11F	68530064

PLASTIC FUNNEL

- Heavy duty polyethylene funnel with filter and flexible spout
- Diameter: 150mm
- Red



Item Code	Bishops Code
	68530020

PLASTIC FLUID FUNNELS

- Durable, versatile and uniquely designed
- Screw down caps at both ends of the funnels ensure that they are contaminant free for the next time you need to use them
- Available in a range of sizes to cater for differing flow requirements



10270CF

10350CF

Item Code	Capacity	Bishops Code
10270CF	1.18L	68530354
10350CF	1.42L – Wide	68530355

SPILL PROOF PLASTIC FUNNELS

- Heavy duty polypropylene construction
- Special contoured design for easy handling
- The curved rim creates an anti-splash and spill proof funnel
- Complete with wire mesh screen, dust cover and flexible spout
- The bung attachment on the larger size allows the funnel to be mounted directly onto drums with 2" thread opening
- Translucent white for a clearer view



Item Code	Capacity	Size	Bishops Code
FNL/8	1.7L	8"	68530340
FNL/9B	3L	9½"	68530350

FUNNEL WITH FLEX SPOUT

- Polypropylene
- Capacity: 1,200cc
- Diameter: 190mm
- Length: 540mm
- Spout length: 160mm
- Weight: 240g



Item Code	Bishops Code
ADX-2001Y	68530330



CAUTION
WET FLOOR

Scott's
Spray & Wipe
Anti-Bacterial
POWERS THROUGH TOUGH
GREASE AND GRIT



10

JANITORIAL, HYGIENE, CRIB & LEISURE PRODUCTS

CLEANING AGENTS

Hand Soaps & Cleaners	399
Barrier Creams	400
Surface Disinfectants & Cleaners.....	400-402
Automotive Cleaners & Polish.....	402
Toilet & Urinal Deodorisers	403

CLEANING EQUIPMENT

Toilet Brush Set	403
Rags, Cloths & Wipes	403-404
Scourers & Sponges.....	404
Brushes, Dust Pans & Boot Cleaners	404
Sweepers & Dust Mops	405
Brooms & Broom Heads	405-406
Squeegees, Mops & Handles	406-407
Buckets & Rubbish Bins	407-409
Janitors Trolley.....	409
Vacuum Cleaners.....	409
High Pressure Cleaners	410-411

CRIB & LEISURE

Coolers, Ice Boxes & Bricks	412
Drinking Water & Beach Umbrella.....	413
Insect Repellents & Ashtrays	413



CONTROL THE SPREAD OF GERMS & VIRUSES

- Wash hands frequently with soap and water for at least 20 seconds (including between your fingers, under your nails and the tops of your hands)
- Avoid touching your eyes, nose or mouth with unwashed hands
- Avoid contact with people who are sick
- Cover your nose and mouth when coughing and sneezing with a flexed elbow or tissue (to be disposed of immediately)
- If you have cold or flu like symptoms or fever, seek medical attention



HOW TO SELECT A HAND CLEANER

Hand Cleaners (Liquid or Bar)

Hand cleaners (soaps) are suitable when hands are visibly dirty, and is effective at removing loosely-adhered soiling. With the correct hand washing technique these cleaners are ideal for general hygiene. Antibacterial options have the added benefit of protection against infection and cross contamination.

Hand Cleaners With Grit

Grit is often added to hand cleaners to assist with the removal of stubborn oil, dirt and grime. Generally used in an industrial environment, the added grit assists in the scrubbing action that loosens tough adhered soiling.

Hand Wipes

Wipes are ideal for removing visible soiling from the hands quickly and without water. The wipe acts as a scrubbing agent assisting in the removal of any visible stubborn contaminates. Wipes are not an alternative to proper hand washing techniques.

Alcohol-Based Hand Sanitisers

Hand sanitisers are quick and easy, only requiring 10-15 seconds. They are recommended for routine hand cleaning when hands are already visibly clean, after contact with any contaminated objects (e.g. used tissues) or before coming into contact with any at-risk people (e.g. the sick, young or elderly). Alcohol-based hand sanitisers are 100 times more effective than ordinary hand cleaners at removing pathogens. If hands are visibly soiled, hand sanitisers are not an alternative to proper handwashing techniques.

What Is Solvent-Free?

Some industrial cleaners contain dangerous solvents derived from crude oil. These solvents are harsh and can be absorbed by the skin. Long term use can lead to harmful levels of toxins in the body. Hand cleaners labelled 'solvent-free' do not contain these solvents.

What Are Conditioners?

Handwashing can lead to dry damaged skin, or irritant contact dermatitis. Dermatitis can affect the integrity of the skin as a barrier to bacteria and pathogens. Added conditioners work to mitigate this effect.

SOLVOL

- Heavy duty hand cleaner
- Trusted for over 95 years to clean the dirty hands of hard working Australians
- Natural citrus oils and fine granule scrub removes ingrained dirt from hands and body
- No petroleum solvents
- pH balanced
- Leaves hands smelling fresh
- Naturally moisturising (liquid only)
- Suitable for removing inks, paints, silicone, glue and more
- Industrial size and easy to use liquid bottles



Item Code	Description	Size	Bishops Code
71128	Solvvol Scrub Soap Bar	100g	32819000
71050	Solvvol Citrus Liquid Hand Cleaner	500ml	32819006

HAND CLEANER GEL

- Remove grease, grime, dirt, oil, wet paint, tar, soot, carbon and much more
- Deodorise hands from the lingering smell of grease oil, paint or even fish and food odours
- Great for use in service bays, machines shops, MRO, commercial and industrial facilities
- Use with or without water
- Contains natural pumice to enhance the cleaning of stubborn dirt and grease



simple green

Item Code	Size
SG42020	20L
SG71001	Drum Pump to Suit

SPECIAL ORDER: PLEASE QUOTE ITEM CODE UPON ORDERING THIS PRODUCT

ELIMINATOR SOLVENT BASED HAND CLEANER

- Paint and resin removing hand cleaner
- Specialty formula removes acrylic and enamel paints, polyester and epoxy resins, urethanes, acrylic sealants and adhesives
- Waterless



Item Code	Size	Bishops Code
IHPE500	500ml	32818210
IHPE4	4L	32818220

CITRA SCRUB HAND CLEANER

- Industrial strength, natural, biodegradable, citrus based hand-cleaner
- Designed to remove dirt, dust, mud, oil, grease, solvents and coal dust
- Ideal for workers in mechanical and industrial workshops, mines, building sites, farms, fishing trawlers and oil rigs



Item Code	Size	Bishops Code
IHCS4	4L	32818160
IHCS20	20kg	32818200

PROTECTA® GRIT SOLVENT BASED HAND CLEANER

- Extra heavy duty industrial hand cleaner
- Speedily removes ingrained tar, carbon, varnish and most industrial soils
- Contains lanolin, aloe vera, vitamin E and jojoba oil to help prevent dry skin
- Includes grit to remove ingrained soils
- Waterless



Item Code	Size	Bishops Code
IHPG4	4L	32818110
IHPG20	20kg	32818115

PROTECTA® PINK GRIT SOLVENT BASED HAND CLEANER

- Extra heavy duty industrial hand cleaner
- Speedily removes ingrained tar, carbon, varnish and most industrial soils
- Contains lanolin, aloe vera, vitamin E and jojoba oil to help prevent dry skin
- Waterless
- Solvent based



Item Code	Size	Bishops Code
IHPP4	4L	32818095
IHPP20	20kg	32818100

WHAT IS BARRIER CREAM?

Barrier creams form a physical barrier between the skin and contaminants that may irritate the skin. Use barrier cream immediately after washing hands, paying particular attention to fingers and fingernails. Allow to dry before starting work. Re-apply after washing hands or as needed.

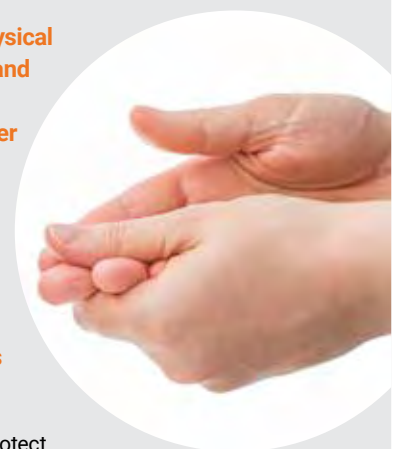

Barrier creams are used to protect hands against cleaning compounds, solvents, acids, oils and other caustic substances.

While somewhat effective at protecting against many skin irritants, barrier creams have not been proven to be as effective as certified PPE (Personal Protective Equipment) and should never be used in place of PPE.

For more hand protection, see the Safety section!



BARRIER CREAM & SURFACE DISINFECTANTS

JANITORIAL, HYGIENE, CRIB & LEISURE PRODUCTS

PROTECTA GUARD BARRIER CREAM

- Solvent resistant barrier cream
- Designed to protect skin against dry powders and dust, grease, oil and solvents
- Non-greasy, non-oily
- Contains added moisturisers
- Size: 500ml



Item Code	Bishops Code
ISPG500	32818080

PROTECTA PLUS BARRIER CREAM

- Water repellent barrier cream
- Designed to protect skin from water, moisture and water-borne irritants, acids, alkalis, electrolyte solutions and wet soils
- Non-greasy, non-oily
- Contains added moisturisers
- Size: 500ml



Item Code	Bishops Code
ISPP500	32818085

GET MORE AT BISHOPS



DISPOSABLE GLOVES

Page 10

ANTIBACTERIAL WIPES

- MEDIQ antibacterial wipes are designed to provide instant cleansing and protection by killing 99.9% of germs
- Ideal for your travel bag, home, car or office for a peace of mind clean
- 75% alcohol
- Wipe size: 15 x 20cm
- 80 per pack



Item Code	Bishops Code
ABW80	32830126

ISOWIPE ALCOHOL WIPES

- Contains 70% isopropyl alcohol
- Highly effective and convenient disinfectant surface wipes kill bacteria and fungi
- Kills COVID-19 and SARS virus in 60 seconds
- Kills fungi (yeast and mould) in 10 minutes
- Kills bacteria (S. Aureus, E. Coli, Ps. Aeruginosa, Pr. Vulgaris)
- Ideal for use on stainless steel and other hard surfaces
- Ideal for high touch areas like door handles, bench tops, handrails, office phones, desks and keyboards
- Individual sheets in a handy dispensing canister
- Wipe size: 420(l) x 143(w)mm
- 75 wipes per pack
- Always read the label and follow the directions of use



Item Code	Bishops Code
CW75	55090150

GLEN 20 SURFACE SPRAY

- Kills influenza virus, mould and mildew
- Eliminates odours
- Hospital grade surface spray disinfectant



Size	Bishops Code
175g	32818128
300g	32818129

WHAT IS THE DIFFERENCE IN GRADES OF DISINFECTANTS?

A disinfectant is a substance which is recommended by its manufacturer for application to an inanimate object to kill micro-organisms. It is not recommended by the manufacturer to be suitable for internal use. But what is the difference between commercial and hospital grade disinfectants?

Commercial Disinfectant: Must be registered with the Australian Register of Therapeutic Goods and comply with parts of the Therapeutic Goods Order Number 54 (TGO 54). Commercial grade disinfectants need to effectively remove Escherichia Coli and Staphylococcus Aureus bacteria in a testing scenario.

Hospital Disinfectant: Must comply with Therapeutic Goods Order Number 54 (TGO 54) and must be registered with the Australian Register of Therapeutic Goods. Hospital grade disinfectant must effectively remove Pseudomonas Aeruginosa, Proteus Vulgaris, Escherichia Coli and Staphylococcus Aureus bacteria in a testing scenario. Disinfectants of this grade are registered for use in medical facilities.

Bleach: A strong and cost effective disinfectant, its active ingredient sodium hypochlorite is effective in killing bacteria, fungi and viruses. Bleach also irritates mucous membranes, the skin and the airways; decomposes under heat and light; and reacts easily with other chemicals. Therefore, use bleach with caution and always ensure there is adequate ventilation. Improper use of bleach, including ignoring the recommended dilutions, may reduce its effectiveness and can result in injury.

WHAT IS THE DIFFERENCE BETWEEN SURFACE CLEANERS?

Below are guidelines on how to select the correct surface cleaner for your job. Before use, always check the applications listed on the product label and complete a patch-test on a small area where damage won't be noticeable.

CAUTION: Many surface cleaning products are toxic.

Always follow the instructions on the label and wear suitable personal protective equipment such as enclosed shoes, coveralls, gloves and safety glasses. All of these products can be found in the Safety section of this catalogue.

General Purpose Cleaners are easy to use and highly versatile, making them suitable for everyday cleaning tasks. Often water-based, each formulation contains one to all of the following.

Surfactants: Allows cleaner to wet surfaces, emulsify soils and pick up dirt

Solvents: Dissolves soil, greases and oils

Chelators: Binds with metal ions and helps clear soap scum

Builders: Adjusts pH to increase cleaner's performance

General purpose cleaners are not suitable for all surfaces. Before use, check the applications listed on the product label.

Graffiti Removers are specifically designed to remove graffiti from particular surfaces (e.g. painted walls, concrete and posters/billboards). Before use, ensure you check the suitable applications on the product label. Graffiti removers are toxic, therefore always follow safety instructions listed on the product.

Kitchen & Bathroom specialised cleaners are designed to remove mineral deposits such as calcium and lime. Most varieties do not contain harsh abrasives, making them suitable for stainless steel and bench tops. If you have a septic system, check the product label to ensure that it is septic safe.

Toilet Cleaners are often harsh, and are not suitable for other surfaces. Chemicals in toilet cleaners can cause skin irritations and toxic vapours. Take care and only use in well ventilated areas with fit-for-purpose protective equipment. If you have a septic system, check the product label to ensure that it is septic safe.

Pipe & Drain Cleaners unclog drains by dissolving any fats, grease, dirt, organic wastes and hair causing the blockage. Most common pipe and drain cleaners are alkaline based and are heavier than water, allowing them to reach the blockage. Pipe and drain cleaners are highly corrosive and toxic, therefore always follow the safety precautions listed on the product label.

Floor & Wall Cleaners are generally mild and water-soluble. Unlike other cleaners this variety tend not to leave residue behind, removing the need to rinse. Many floor and wall cleaners come in dedicated varieties, choose one that is appropriate for your surface.

Glass Cleaners contain surfactants and solvents which lift the dirt and grime, leaving a shiny surface. To ensure a streak-free shine, the solution must be wiped up before the product evaporates. General glass cleaners are not suitable for automotive use.

Automotive Cleaners are gentle, primarily composed of surfactants lifting the superficial dirt from the vehicle surface without damaging the paint work itself. Variations often include other agents such as rinse aids and gloss enhancers.

SPRAY & WIPE

- Ready to use hard surface cleaner
- Ammonia free, contains fresh lemon fragrance
- Removes smears, water based inks, finger marks, cooking oils and greases
- Cleans most surfaces including walls, laminates, whitegoods, chrome and stainless steel
- Safe on paintwork, won't damage upholstery or rubber
- 750ml trigger spray



SEPTONE

Item Code	Bishops Code
HGSW750	32818130

SIMPLE GREEN RTU & REFILLS

- Ready-to-Use All Purpose Cleaner is ideal for use on any indoor or outdoor washable surface, in the office and at home, or take it outside to use on garage floors, tools, bikes and patio furniture
- Simple Green Glass Cleaner does not contain harmful ammonia or bleach
- Easily removes fingerprints, smudges and other grime, to reveal a crystal clear shine
- All Purpose Simple Green also comes as an economical concentrate in both Original and Lemon Fragrances
- Safer, biodegradable formulas

simple green



Item Code	Description	Size
SG02496	All Purpose RTU Original Fragrance	946ml
SG16071	All Purpose RTU Lemon Fragrance	946ml
SG16072	Glass Cleaner RTU	946ml
SG13005R	All Purpose Concentrate Original Fragrance	3.78L
SG14010A	All Purpose Concentrate Lemon Fragrance	3.78L

SPECIAL ORDER: PLEASE QUOTE ITEM CODE UPON ORDERING THIS PRODUCT

CRYSTAL CLEANER & DEGREASER

- Crystal Simple Green Industrial Cleaner and Degreaser is a powerful, industrial-strength concentrate suitable for critical cleaning applications
- NSF labelled A1, A2, A4, A8, B1 and C1 for use in commercial kitchens, food processing plants and other areas where food is prepared or handled
- Quick Break formulation eliminates grease and grime, animal fats, oils, lubricants, baked on carbons, starches and other organic soils without harsh scrubbing
- Higher foaming, readily biodegradable formula rinses residue free
- Not classified as hazardous according to Model Work Health & Safety Regulations and GHS Criteria

simple green



Item Code	Size
SG19024	710ml
SG19128	3.78L
SG19001	20L
SG19054	200L
SG19275	1,000L

SPECIAL ORDER: PLEASE QUOTE ITEM CODE UPON ORDERING THIS PRODUCT



INDUSTRIAL SURFACE CLEANERS, DEGREASERS & PROTECTANTS

JANITORIAL, HYGIENE, CRIB & LEISURE PRODUCTS

INDUSTRIAL CLEANER & DEGREASER

simple green

- A powerful, concentrated all-purpose cleaner and degreaser that provides a safer alternative to other cleaners, bleaches and solvents
- Recognised by the U.S. EPA's Safer Choice Program as safer for people and the environment
- Ideal for a wide range of industries including manufacturing, mining, automotive and engineering
- Quick Break formulation cuts through tough grease, oils, cutting fluids, built-up grime and residue
- Readily biodegradable (per OECD 301D)
- Not classified as hazardous according to Model Work Health & Safety Regulations and GHS Criteria



Item Code	Size	Bishops Code
SG13033	946ml	*SG13033
SG13005	3.78L	*SG13005
SG13004	20L	32814076
SG13034	200L	32814080
SG13275	1,000L	*SG13275

* - SPECIAL ORDER: PLEASE QUOTE ITEM CODE UPON ORDERING THIS PRODUCT

TW20 TRUCK WASH

SEPTONE

- Concentrated vehicle detergent cleaner
- Neutral pH
- Quick break, biodegradable formula
- Easily removes road grime, oil, soot and more from vehicle exteriors
- Safe on all paint finishes



ATTW20

Item Code	Size	Bishops Code
ATTW5	5L	32812004
ATTW20	20L	32812006

TRUCK WASH

simple green

- Used to wash trucks, earth moving machinery, trams, buses, trains, cars, boats, etc.
- Can be used with automated wash, pressure washer, foaming gun, spray pack, brush or sponge
- Lower foaming so less water is required when rinsing
- Features Quick Break so is ideal in wash bays equipped with an oil/water separator
- 20L of concentrate will make 600L of ready-to-use product at a dilution of 1:30
- Not classified as hazardous according to Model Work Health & Safety Regulations and GHS criteria



Item Code	Size	Bishops Code
SG13480	20L Drum	32812008
SG13482	200L Drum	*SG13482
SG13487	1,000L IBC	*SG13487

* - SPECIAL ORDER: PLEASE QUOTE ITEM CODE UPON ORDERING THIS PRODUCT

WHAT ARE SURFACE PROTECTANTS??

A protectants purpose is to protect and preserve. The use of protectant will keep surfaces looking newer for longer.

Glass Protectant

Ideal for vehicle windscreens. It repels rain, sleet and snow on contact, improving driver's visibility. The invisible, non-stick protectant layer also makes for easy removal of bugs, salt, mud and frost.

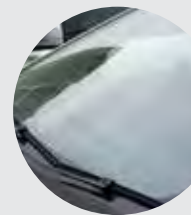

Furniture Protectant

Suitable to use on a variety of surfaces such as wood, enamel, leather, glass and plastic. A layer of furniture protectant will add shine, protect wood from watermarks and keep dust from settling.



Metal Protectant

Suitable for use on aluminium, copper, brass and fibreglass. It protects metals against stains, rust and weathering. A layer of protectant will also polish metal for a shiny appearance.

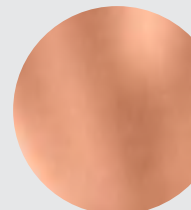

Automotive Protectant

This can be used both interior and exterior to protect vehicles from UV rays and provide a shiny appearance. The use of protectant will prolong paint or material life and help mask minor scratches and swirl marks.

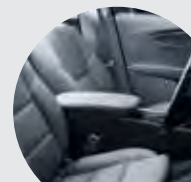

ARMOUR COLOGNE

SEPTONE

- Perfumed surface rejuvenator
- Protects and beautifies
- Ideal on leather, vinyl, rubber and plastics
- Leaves a pleasant lingering deodorant
- 750ml trigger spray



Item Code	Bishops Code
AVAC750	32812145

METAL POLISH

SEPTONE

- Versatile polish suitable for polishing of most non-precious metals including stainless steel, chrome, nickel, brass, copper and aluminium
- Contains high quality wax for surface protection



Item Code	Size	Bishops Code
APMP250	250g	32812210

URINAL SCREEN PADS

- Freshens for up to 30 days
- Reduces splash back
- Gradually releases fragrance
- Reduces cleaning time
- Flexible, translucent vinyl
- Optimal flow through the drain while trapping debris
- Month tabs for replacement reminder
- Diameter: 170mm
- 2 per pack



Item Code	Scent	Colour	Bishops Code
USPBL	Ocean Mist	Blue	32816060
USPRED	Strawberry	Red	32816061

TOILET DEODORANT BLOCKS

- Biodegradable
- Long lasting and dependable
- Will not crumble or dissolve in water
- Economical alternative to other air freshener
- Air freshener and odour suppressant
- Suitable for toilets, bathrooms and urinals
- 4kg tub
- 25g blocks
- Approx. 160 blocks per tub



Item Code	Bishops Code
11725-16FRE	66550242

TOILET TIDY & BRUSH SET

- Tough bristles for a thorough clean
- Compact and lightweight design
- Corner design facing inward allows discreet storage of toilet brush



Item Code	Bishops Code
TBCAD	62574804

MIXED RAGS

- Suitable for cleaning
- 15kg bale



Bishops Code
32830020

COLOUR CODED CLEANING SYSTEM

Protect your workplace from cross contamination by colour coding your cleaning equipment. Mops, buckets, cleaning cloths and more are all available from Bishops in a variety of colours to keep your workplace safe.



MICROFIBRE CLOTHS

- Microfibre properties trap and remove particles
- No chemicals or polishes required
- Ideal for wet or dry use on electronic goods and multiple surfaces



Colour	Bishops Code
Blue	32830040
Green	32830042
Red	32830044

CONTRACTOR WIPES ON A ROLL

- Extra thick, highly absorbent and quick drying
- Commercial strength
- Reusable
- Perforated sheets for easy tear off
- Colour coded series available to help avoid the risk of cross contamination between work areas
- Sheet size: 300 x 500mm
- 90 wipes per roll
- 45m roll
- Blue



Bishops Code
32830108



WIPES, SCOURERS & BRUSHES

JANITORIAL, HYGIENE, CRIB & LEISURE PRODUCTS

X30 BLUE WIPES

- 150 sheets per box



Item Code	Bishops Code
68301	32830125

SCOURER PAD



- Aggressive commercial grade scourer for removing tough grime
- Ideal for cleaning pots, cooking utensils and metal surfaces
- Size: 150 x 100mm
- Green
- 10 per pack



Bishops Code
32830032

SCOURER SPONGES



- Aggressive commercial grade scourer for removing tough grime
- Ideal for cleaning pots, cooking utensils, and metal surfaces
- Yellow/green
- 10 per pack



Bishops Code
32830038

STAINLESS STEEL SCOURER



- Manufactured from premium stainless steel
- Continuous filament for less linting
- 50g



Bishops Code
32830036

WOODEN BACK SCRUBBING BRUSH



- Industrial grade hard wearing bristles
- Two tier bristle levels ideal for scrubbing uneven surfaces
- Wooden back
- Dimensions: 185(l) x 55(w) x 45(h)mm



Item Code	Bishops Code
BSFB185	62512942

SINGLE WING SCRUB BRUSH



- Stiff, durable bristles remove tough grime
- General purpose hand brush ideal for scrubbing floors and other surfaces
- Wooden back



Item Code	Bishops Code
BSTT215	62512940

COCO BANNISTER BRUSH



- Wooden handle
- Coco-fibre bristles
- Hole in handle for easy hanging
- Dimensions: 270(l) x 40(w) x 55(h)mm



Bishops Code
62512920

PLASTIC DUSTPAN & BRUSH SET



- Side ridges effectively clean the brush and remove hair
- Flagged bristles trap dirt
- Available in colour coded range to help reduce the risk of cross contamination between work areas
- Blue



Bishops Code
62574800

3 SIDED BOOT CLEANER



- 3 sided brush provides optimum cleaning
- Frame is constructed from industrial strength steel
- Heavy duty bristles make removing dirt and mud from boots easier
- Black frame and brushes
- 215(w) x 370(d) x 505(h)mm
- Weight: 7.1kg

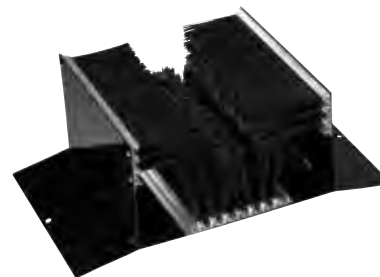

Bishops Code
62574990

ALL-PURPOSE LOBBY PAN SET

- Upright dust pan and broom set
- Medium stiff bristles trap dirt
- Deep pan for large cleaning jobs



Bishops Code
62574802

MODACRYLIC DUST MOP

- Sturdy metal frame swivels into hard-to-reach places
- Highly resilient and durable Modacrylic fibres capture dirt, lint and dust
- 900mm
- Orange



Description	Bishops Code
Dust Mop with Handle	62574830
Replacement Head	62574835

WET & DRY MANUAL FLOOR SWEEPER

- Durable, corrosion-free, impact resistant engineering plastic
- Dual counter rotating brushes collect dust, heavier debris and provide edge cleaning from both sides of the unit
- Cleans larger areas quickly, easily and thoroughly
- Ideal for cleaning paths, driveways, storefronts, garages, poolside and movie theatres quickly and conveniently
- Wear-resistant, belt-free direct drive
- Operates without any fuel, oil or electricity
- Ergonomically designed, adjustable handle for fatigue-free operator comfort



Item Code	Bishops Code
MS80	62574992

TRADEMAN'S POLY BROOM

- Poly/medium tradesman with steel handle broom
- Complete with 1.47m x 25mm powdercoated steel handle
- Fluorescent yellow for improved visibility
- Ergonomic comfort grip on handle
- Medium stiff dual fill polypropylene bristles
- Stiff yellow inner fill picks up small and medium sized particles
- Outer soft black fill ideal for collecting dust and dirt
- Designed for wet or dry, rough or uneven surfaces, timber, bricks and concrete

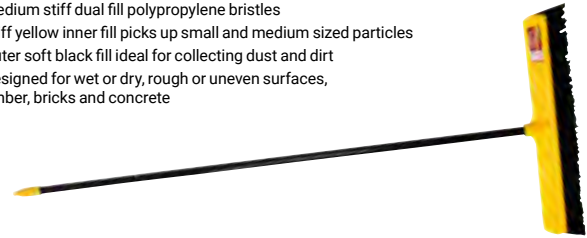

Head Size	Bishops Code
450(l) x 65(w) x 130(h)mm	62574264
600(l) x 110(w) x 160(h)mm	62574266

INDOOR BROOM HEAD

- Indoor soft bristle broom
- Perfect for site shed
- Small head for maneuverability
- Suits 22mm screw-in handle
- Handle not included
- Dimensions: 290(l) x 60(w)mm



Description	Bishops Code
Standard Indoor Broom Head	62574422
Superior Indoor Broom Head	62574424

PLASTIC BACKED BROOM HEAD

- Plastic backed, hard wearing
- Suits small and medium size particles
- Ideal for use on bitumen or paving
- Suits 25mm push-in handle
- Head size: 450(l) x 65(w) x 130(h)mm
- Handle not included
- Yellow



Item Code	Bishops Code
BROPBY450	62574250

POLY EXTRA STIFF BROOM HEAD

- Plastic backed, hard wearing
- Extra stiff bristles suit collection of large and heavy debris
- Ideal for use on bitumen or paving
- Suits 25mm push-in handle
- Head size: 600(l) x 65(w) x 140(h)mm
- Handle not included
- Yellow



Item Code	Bishops Code
	62574280



BROOM HEADS, SQUEEGEES & MOPS

JANITORIAL, HYGIENE, CRIB & LEISURE PRODUCTS

FRONT YARD CANE BROOM



- Extra stiff blend of natural bassine and cane bristles effectively collect large particles
- Resistant to moisture and heat
- Ideal for use on roads and heavy bitumen
- Handle not included
- 350mm



Bishops Code
62574420

HARD CENTRE INDUSTRIAL PLATFORM BROOMS



- Medium duty use
- Java, coco and synthetic blend bristles collect fine particles and minimise airborne dust
- Ideal for use on indoor factory floors
- Handle not included



Size	Bishops Code
450mm	62574020
600mm	62574040

TIMBER BACKED BROOM HEAD



- Natural fibre bassine bristles effectively collect small and large particles
- Ideal for use on pavers, cement and hot bitumen
- Handle not included
- 600mm



Bishops Code
62574320

SQUEEGEE HEAD



- Rubber squeegee on wooden frame
- Ideal for pushing and pulling liquids
- Suits 25mm push-in handle
- Handle not included
- Head length: 610mm



Bishops Code
62574512

ALUMINIUM FLOOR SQUEEGEE



- Highly durable grease resistant rubber on a rust resistant aluminium frame
- Ideal for pushing and pulling liquids on large concrete surfaces
- Ideal for kitchens
- Red rubber
- Handle not included
- 450mm



Bishops Code
62574510

FOUR POST SQUEEZE MOP



- Extra thick sponge for greater absorbency
- Wider sponge for greater floor coverage
- Extra long scour for removing stubborn marks
- Ergonomic locking nuts allow for easier fitting and removal of sponge refill



Description	Bishops Code
Four Post Squeeze Mop	62574820
Sponge Refill	62574821

COTTON MOP HEADS



- 100% cotton yarn
- Industrial strength multi-use mops
- Ideal for commercial cleaning
- Suits 22mm screw-in handle
- Handle not included



Head Weight	Bishops Code
350g	62574810
450g	62574812

POLY/COTTON MOP HEAD



- Polyester and cotton blend yarn ideal for applying sealers and polish
- Suitable for use on rough surfaces due to high lint resistance and durability
- Head weight: 450g
- Handle not included
- Blue mount



Bishops Code
62574819

CONTRACTOR COTTON MOP HEAD

- 100% cotton yarn
- Industrial strength multi-use mop
- To suit 22mm screw-in handle
- Handle not included
- Head weight: 500g



	Bishops Code
	62574815

DURACLEAN MOP HEAD

- Exclusive synthetic blend yarn for ultimate absorbency and cleaning performance
- Unsurpassed durability makes it ideal for all heavy duty commercial cleaning jobs
- Head weight: 400g
- Blue



	Bishops Code
	62574818

COLOUR CODED MOP HEADS

- Synthetic yarn fibres
- Industrial strength multi-use mops
- Ideal for commercial cleaning
- Suits 22mm screw-in handle
- Handle not included
- Head weight: 400g



Description	Bishops Code
General – Blue	62574805
Kitchen – Green	62574806
Bathroom – Red	62574807
Infectious – Yellow	62574808

WOODEN HANDLES

- Composite bamboo and timber handle for superior strength, flexibility and durability
- Using advanced technologies and materials sourced from renewable plantations
- High quality lacquer finish for added protection
- Features natural protection against constant water exposure, weathering, splintering, and damage caused by insects and other environmental factors resulting in increased life expectancy
- Ideal for heavy duty commercial use and worksites



Size	Bishops Code
1.35m x 22mm	62574901
1.50m x 25mm	62574902
1.80m x 25mm	62574903

METAL BROOM HANDLE

- Industrial multi-use handle
- Heavy duty lightweight steel
- Metal thread adaptor
- Suits head with 22mm threaded socket
- 22(dia)mm x 1.5(l)m



Item Code	Bishops Code
BROH15	62574920

ALUMINIUM CONTRACTOR HANDLE

- Ideal for commercial use
- Available in colour coded range to avoid cross contamination between different work areas
- 1.5(l)m x 25(w)mm
- Blue



	Bishops Code
	62574922

CONTRACTOR WRINGER MOP BUCKET

- Heavy duty plastic body is lightweight and hygienic
- Non-slip foot pedal and castors provide greater manoeuvrability
- Capacity: 15L
- Yellow



Capacity	Bishops Code
15L	62576048

DURACLEAN WRINGER MOP BUCKETS

- Dual action roller wringer bucket
- Lightweight plastic construction
- Non-marking castors
- Non-slip foot pedal
- Capacity: 15L



Colour	Bishops Code
Blue	62576044
Red	62576045
Green	62576046
White	62576047
Yellow	62576050



BUCKETS & BINS

JANITORIAL, HYGIENE, CRIB & LEISURE PRODUCTS

9L PLASTIC BUCKET



- Everyday multi-purpose bucket
- Handy pouring spout for easy transfer of liquids
- Ergonomic handle with comfort grip
- Capacity: 9L
- Blue



Capacity	Bishops Code
9L	62576040

9L PLASTIC BUCKET

- Round plastic bucket with pourer
- Wire carry handle for extra strength
- Capacity: 9L
- Colour may vary



Capacity	Bishops Code
9L	62576030

RUBBER BUCKET WITH POURING LIP

- High grade moulded rubber
- Reinforced profile
- Galvanised steel carry handle
- Capacity: 15L



Capacity	Bishops Code
15L	62576056

GALVANISED STEEL BUCKET

- Galvanised steel
- Comes complete with handle
- Capacity: 10L



Item Code	Bishops Code
90560024	62576014

STAINLESS STEEL BUCKETS

- Metal handle
- Stainless steel



Capacity	Bishops Code
8L	62576011
12L	62576010
16L	62576013

ROUND LID RUBBISH BIN

- Suitable for use in the kitchen, bathroom, office and garage
- Capacity: 50L
- 400(l) x 400(w) x 730(h)mm



Capacity	Bishops Code
50L	86410055

UTILITY BIN WITH LID

- Durable plastic bin with domed lid
- Suitable for outdoor use
- Capacity: 60L
- 460(l) x 460(w) x 580(h)mm



Capacity	Bishops Code
60L	86410070

GET MORE AT BISHOPS ▶



CLEANERS & DEGREASERS

Page 448

WHEELIE BINS

- Robust high performance design
- Comes with lid and wheels in a variety of colours



Colour	Capacity	Bishops Code	Colour	Capacity	Bishops Code
Blue	120L	86410045	Black	240L	86410074
Yellow	120L	86410046	Red	240L	86410076
Blue	240L	86410073	Orange	240L	86410075
Green	240L	86410071	Brown	240L	86410077
Yellow	240L	86410072	Purple	240L	86410078

JANITORS TROLLEY

- Lightweight and sturdy design with provision for many accessories to be hung
- Compact size for easy manoeuvrability into elevators and tight passageways



Item Code	Bishops Code
	32830046

SE 62 WET & DRY VACUUM CLEANER



- Suitable for domestic and light commercial applications
- Hygienic, economical and eco-friendly washable filter cartridge
- Aluminium suction pipe
- All purpose floor tool
- Automatic filter cleaning
- Max. capacity: 1.3W
- Suction volume (air): 3.6L/min
- Weight: 6.9kg



Item Code	Bishops Code
4784 012 4405	79030452

SE 133 WET & DRY VACUUM CLEANER



- Full wet and dry vacuum cleaners with automatic switch-on function in dust class M
- Automatic filter cleaning without loss of suction power
- Automatic volume flow monitoring
- Infinitely variable speed control
- Adaptor plates for carrying tool boxes
- Anti-static accessories also for extraction on battery-powered electric power tools
- Max. power consumption: 1,400W
- Maximum vacuum pressure: 250mbar
- Suction volume: 4,500L/min
- Container volume: 42L
- Sound pressure level: 68dB(A)
- Mains voltage: 220-240/1~/50-60V/Hz
- Suction hose length: 5m
- Hose diameter: 32mm
- Weight: 16kg



Item Code	Bishops Code
4786 012 4434	79030455

SE 33 WET & DRY VACUUM CLEANER



- For cleaning dry and wet areas near the home and for car cleaning
- Versatile use due to an extensive range of accessories
- Accessories include: Switchable floor nozzle for flexible changeover between wet and dry vacuuming, blow function by moving the suction tube onto the exhaust port, ergonomic two-part suction tube
- Ideal storage of accessories directly on the power tool, crevice nozzle, floor nozzle, 2m vacuum hose
- Max. power consumption: 1,400W
- Max. vacuum pressure: 210 mbar
- Suction volume: 3,600L/min
- Suction flow: 3,600L/min
- Sound pressure level: 73dB(A)
- Mains voltage: 220-240/1~/50 - 60 V/Hz
- Suction hose length: 2m
- Hose diameter: 37mm
- Weight: 5.4kg



Item Code	Bishops Code
SE01 012 4404	79030450

SE 122 WET & DRY VACUUM CLEANER



- Suitable for professional applications
- Hygienic, economical and eco-friendly washable filter cartridge
- Aluminium suction pipe
- All purpose floor tool
- Automatic filter cleaning
- Lockable swivel wheels
- Stainless steel hand and suction tubes with quick-action coupling
- Max. capacity: 1.5W
- Suction volume (air): 3.7L/min
- Weight: 10kg



Item Code	Bishops Code
4774 012 4401	79030454



HIGH PRESSURE CLEANERS – ELECTRIC

JANITORIAL, HYGIENE, CRIB & LEISURE PRODUCTS

RE 110 PLUS PRESSURE WASHER



- Convenient and portable high pressure cleaner
- Aluminium pump head
- Brushless induction motor
- Integrated wheel kit
- Cleaning agent spray set, rotary nozzle, adjustable fan jet nozzle with pressure regulation
- Anti-drill quick-release coupling on the trigger and tool
- Park position for switching off the sprayer during breaks
- Comes with 7m high pressure hose and transport handle
- Particularly long sprayer for convenient operation
- Aluminium telescopic handle
- Storage compartment on the side with integrated nozzle and power cable storage
- Working pressure: 110bar
- Max. pressure: 120bar
- Power cable length: 5m
- Max. water supply temperature: 40 °C
- Power performance: 1.7W
- Rated voltage: 240V
- Weight: 17.6kg



Item Code

4950 011 4536

Bishops Code

79010302

RE 130 PLUS PRESSURE CLEANER



- Powerful high-pressure cleaner with exceptional comfort
- Aluminium pump head
- Brushless induction motor
- Integrated wheel kit
- Cleaning agent spray set, rotary nozzle, adjustable fan jet nozzle with pressure regulation
- Anti-drill quick-release coupling on the trigger and tool
- Sturdy, durable 9m steel-reinforced high-pressure hose and hose reel
- Reinforced transport handle
- Particularly long sprayer for convenient operation
- Aluminium telescopic handle
- Storage compartment on the side with integrated nozzle and power cable storage
- Max. working pressure: 150bar
- Working pressure: 135bar
- Max. pressure: 150bar
- Power cable length: 5m
- Max. water supply temperature: 40 °C
- Power performance: 2.3W
- Rated voltage: 240V
- Weight: 21.2kg



Item Code

4950 011 4564

Bishops Code

79010306

RE 170 HIGH PRESSURE CLEANER



- Wear-resistant, ceramic-covered pistons ensure a heavy duty pump together with the brass pump head for a long service life
- Integrated high-pressure hose reel with guide and folding crank
- Aluminium telescopic handle
- Variable pressure fanjet nozzle
- 240V
- Power consumption: 2.4kW
- Max. working pressure: 120bar
- Max. water throughput: 7.8L/min
- Max. temperature: 60°C
- High pressure hose length: 12m
- Weight: 31kg



Item Code

RE01 011 4534

Bishops Code

79010308

BLACK BOX ELECTRIC COLD WATER PRESSURE CLEANER & TROLLEY

- Compact and portable high pressure cleaner
 - Suitable for light domestic, workshop and commercial applications
 - High level of performance and working life
 - Brass head triplex pump
 - Detergent injection
 - 240V, 2.6kW, 4 Pole
 - Flow rate: 8L/min,
 - Max. pressure: 2,175psi (140 bar)
 - Working pressure: 1,800psi (124 bar)
 - Working pressure (with Turbo Lance): 3,400psi
 - 390(l) x 240(w) x 230(h)mm (without trolley)
 - Weight: 30kg
- Includes:**
- 8m wire braided hose
 - Gun/lance assembly & Turbo Lance
 - Heavy duty trolley (not pictured)



Item Code

FKB8.15TR

Bishops Code

79010340

MONSOON 200 ELECTRIC COLD WATER PRESSURE CLEANER

- Designed for tough conditions and long continuous operation
 - Suitable for heavy industries, ship yards, car detailers and food plants
 - Heavy duty Tiplax pump
 - Circuit breaker with thermal trip and short circuit protection
 - Integrated hose mount
 - Steel wheels with flat-free tyres
 - Detergent injection
 - IP65 rated casing
 - 415V, 5.5kW, 4 Pole
 - Flow rate: 15L/min,
 - Working pressure: 3,000psi (200 bar)
 - Working pressure (with Turbo Lance): 4,785psi
 - 700(l) x 580(w) x 550(h)mm
 - Weight: 70kg
- Includes:**
- 10m high pressure hose
 - Gun/lance assembly
 - 2 x Nozzles - laser cut & detergent
 - Aussie safety protection kit



Item Code

ABMONSS200

Bishops Code

79010480

MONSOON 140 ELECTRIC COLD WATER PRESSURE CLEANER

- Heavy duty professional high pressure washer
 - Designed for tough conditions and long continuous operation
 - Suitable for heavy industries, ship yards, car detailers and food plants
 - Heavy duty Tiplax pump
 - Circuit breaker with thermal trip and short circuit protection
 - Robust stainless steel frame
 - Steel wheels with flat-free tyres
 - Detergent injection
 - IP65 rated casing
 - 240V, 2.2kW, 4 Pole
 - Flow rate: 9L/min,
 - Working pressure: 2,000psi (140 bar)
 - Working pressure (with Turbo Lance): 3,400psi
 - 680(l) x 580(w) x 550(h)mm
 - Weight: 52kg
- Includes:**
- 8m high pressure hose
 - Gun/lance assembly
 - Aussie safety protection kit



Item Code

ABMONSS140

Bishops Code

79010350

SUPER INDY ELECTRIC HOT WATER PRESSURE CLEANER

- Slow speed heavy duty high pressure steam cleaner
- Specially designed for primary producers and earthmoving contractors
- Brass head Triplex pump and mild steel heavy duty coil
- High pressure detergent injection
- Stainless steel cover, steel chassis and bumper
- 250mm wheels
- Low water and fuel sensors, and safety auto shut-off
- 415V, 5.5kW, 4 Pole, 3 phase
- Flow rate: 16L/min,
- Working pressure: 3,000psi (200 bar)
- Working pressure (with Turbo Lance): 4,785psi
- Max. temperature: 120°C
- 1,070(l) x 740(w) x 920(h)mm
- Weight: 190kg

Includes:

- 18L diesel tank
- 8m high pressure hose
- Pro gun & 700mm lance
- Laser cut nozzle



Item Code	Bishops Code
FS/INDDSS2016TV3	79020640

SCUD AB30 DIESEL COLD WATER PRESSURE CLEANER

- Compact high pressure cleaner
- Suitable for trade and commercial applications
- Stainless steel frame
- 250mm steel wheels with flat-free tyres
- Detergent injection
- Honda GX200 engine, 6.5hp
- Flow rate: 10L/min,
- Working pressure: 3,000psi (210 bar)
- Working pressure (with Turbo Lance): 4,785psi
- Weight: 45kg

Includes:

- 8m high pressure hose
- Gun/lance assembly and Turbo Lance
- Aussie Safety Protection kit



Item Code	Bishops Code
ABSS30/GX200	79030400

RB 600 HIGH PRESSURE CLEANER



- For professional and commercial cleaning jobs
- Designed for handling heavy-duty projects with ease
- Pump components made of premium commercial-grade Triplex to reinforce its durability
- Easy start pump system allows you to start the washer without difficulty or back pressure from the pump
- Rated pressure: 3,200 psi
- Permissible pressure: 220bar
- Water flow rate: 11.3L/min
- Power: 5.2kW
- Displacement: 208cm³
- High pressure hose: 40ft
- Nozzle angles: 15/25/40/65°
- Weight: 53.5 kg
- Sound pressure level: 90.2 LpA dB(A)
- Sound power level: 103 LWA dB(A)



Item Code	Bishops Code
4791 012 4604	79010312

SCUD 400 DIESEL COLD WATER PRESSURE CLEANER

- Engine powered high pressure cleaner
- Suitable for heavy duty continuous cleaning including construction site, plant wash-down and graffiti removal
- Brass head Triplex pump
- Robust galvanised frame
- Steel wheels with tough terrain tyres
- Yanmar L100 ES engine, 10hp
- Electric start
- Flow rate: 15L/min,
- Working pressure: 4,000psi (275 bar)
- Working pressure (with Turbo Lance): 6,485psi
- 1,100(l) x 800(w) x 950(h)mm
- Weight: 110kg

Includes:

- 10m high pressure hose
- 4,000psi rated hand gun
- 2 x Nozzles - laser cut & detergent



Item Code	Bishops Code
ABSS400/L100E	79030420

RB 800 HIGH PRESSURE CLEANER



- For professional and commercial cleaning jobs
- Designed for handling heavy-duty projects with ease
- Pump components made of premium commercial-grade Triplex to reinforce its durability
- Easy start pump system allows you to start the washer without difficulty or back pressure from the pump
- Rated pressure: 4,200 psi
- Permissible pressure: 290bar
- Water flow rate: 15.1L/min
- Power: 10.5kW
- Displacement: 429cm³
- High pressure hose: 50ft
- Nozzle angles: 15/25/40/65°
- Weight: 76kg
- Sound pressure level: 93.3 LpA dB(A)
- Sound power level: 106.1 LWA dB(A)



Item Code	Bishops Code
4792 012 4604	79010314

PREDATOR A KDE DIESEL COLD WATER PRESSURE CLEANER

- Heavy duty high pressure cleaners for the toughest of cleaning jobs
- Brass head Triplex pump
- Air cooled diesel engine and gearbox drive
- Stainless steel frame with anti-vibration mounts
- 405mm steel wheels with pneumatic tyres
- Fitted with emergency stop and fire extinguisher
- Kohler KD625 engine, 25hp
- Flow rate: 16L/min
- Working pressure: 5,000psi (350 bar)
- Working pressure (with Turbo Lance): 8,500psi
- 1,250(l) x 800(w) x 1,130(h)mm
- Weight: 280kg

Includes:

- 10m high pressure non-marking hose
- Spray gun
- 800mm single lance
- Laser cut nozzle
- Aussie Safety Protection kit



Item Code	Bishops Code
ABSSPRED-A/KDE	79030440



COOLERS & HYDRATION

JANITORIAL, HYGIENE, CRIB & LEISURE PRODUCTS

WATER COOLER JUGS

- Polyurethane insulation to keep drinks cool
- Smaller sizes (2.5, 5 and 10L) come with a drinking cup lid
- A variety of sizes available to suit all occasions
- Suitable for recreational and workplace use



Description	Capacity	Size	Bishops Code
Without Tap	2.5L	200(l) x 200(w) x 240(h)mm	86410200
With Tap	5L	240(l) x 240(w) x 300(h)mm	86410210
With Tap	10L	280(l) x 280(w) x 360(h)mm	86410220
With Tap	15L	340(l) x 340(w) x 360(h)mm	86410225

COOLERS

- Polyurethane insulation to keep food and drinks cool
- A variety of sizes available to suit all occasions
- Suitable for recreational and workplace use



Capacity	Bishops Code
25L	62022225
55L	62022235

IGLOO® WATER COOLERS

- Cooler maintains ice for 3 days at 32°C
- High-visibility safety yellow colour
- "Drinking water" imprint meets OSHA labelling requirements for water used on jobsites
- UV inhibitors protect against sun damage
- Reinforced swing-up carry handle for easy transport
- Pressure-fit lid won't trap dirt or mould
- Recessed and angled drip-resistant spigot for easy dispensing
- Front push-button spigot is easy to access when wearing gloves on a worksite



Capacity	Bishops Code
20L	86410226
40L	86410228

ICE BOXES



- Heavy duty ice boxes
- Rotomoulding construction
- Polyurethane insulation
- Can be strapped down
- Suitable for outdoor use, camping and work sites



Item Code	Capacity	Bishops Code
C56L	56L	62022240
CZ90W	90L	62022242
CZ109LW	109L	62022244

ICE BRICKS

- No mess alternative to ice
- Non-toxic
- Reusable



Size	Bishops Code
150ml - 3 Pack	62022236
350ml	62022237
750ml	62022238

CARRY CONTAINER WITH POURER

- Lightweight multi-purpose carry can
- Can store water, industrial detergents and chemicals
- Convenient pourer prevents spills and splashing
- Can be easily stored in the car, boat and caravan
- Capacity: 20L
- 340(l) x 140(w) x 510(h)mm
- Blue



Capacity	Bishops Code
20L	62022220

GET MORE AT BISHOPS



SUNSCREEN

Page 33

BOTTLED DRINKING WATER

- 600ml
- Carton of 24, sold individually



Bishops Code
62022172

COOLAROO BEACH UMBRELLA

- Made with Coolaroo fabric
- Powder coated steel frame
- Tilt head
- Diameter: 1.85m



Bishops Code
55010290

BUSHMANS INSECT REPELLENT WITH DEET

- Gel formula
- Water, sweat and rub resistant
- Suitable for use on sensitive skin
- Pleasant neutral odour
- 80% DEET content
- 12 hours protection
- Size: 75g



Item Code 88891589 **Bishops Code** 32818070

AEROGARD INSECT REPELLENT

- Tropical strength
- Provides 6 hour protection against mosquitoes
- Also repels flies, sandflies, leeches, ticks and other annoying and biting insects



Size **Bishops Code**
50ml Roll On 32818075
150g Aerosol 32818076
300g Aerosol 32818077

THERMACELL REPELLERS & REFILL KITS



- Effectively repels mosquitoes, black flies and other biting insects
- Creates a 21m square zone of protection for bug-free comfort
- Ideal for camping, fishing, 4WD and caravans
- Lantern and Portable Repeller bright 220 lumen light has a 10 hour run time
- Operates for up to 40 hours on it's lowest setting
- Backpacker Repeller offers up to 90 hours of run-time from a 110g gas canister and works dependably up to an altitude of around 2,100 metres
- Gas canisters must be purchased separately



THMRBP

THMR300B

THMRCLC



THM24



THR1



THR4

Item Code	Description	Includes
THMRBP	Backpacker Repeller	3 x 4-Hour Mats
THMR300B	Portable Insect Repeller	12hr Refill
THMRCLC	Scout Lantern Insect Repeller	12hr Refill

REFILLS		
THM24	24hr Refill	6 x 4-Hour Mats
THR1	12hr Refill	3 x 4-Hour Mats & 1 x Butane Cartridge
THR4	48hr Refill	12 x 4-Hour Mats & 4 x Butane Cartridges

SPECIAL ORDER: PLEASE QUOTE ITEM CODE UPON ORDERING THIS PRODUCT

CIGARETTE BUTT DISPOSAL

- Safe and attractive way of handling unsightly cigarette butts
- Polyethylene construction with flame retardant additive
- Will not rust, dent, crack or peel
- The large head dissipates heat
- The covered top keeps out rain and any other litter
- Moulded graphics in the head clearly identify the opening for cigarettes
- The large neck cavity minimises clogging
- the Cease-Fire design limits the flow of oxygen reducing the risk of fires
- The broad base contains removable 9L galvanised steel liner bucket for easy cleaning
- Made with moulded-in tie-down notches on both sides of the base for security
- Grey
- Height: 1,200mm
- Base: 420mm
- Disposal opening: 40mm



Item Code 1533 **Bishops Code** 86410094



11

LUBRICANTS, SEALANTS & CHEMICALS



LUBRICATION & FUEL EQUIPMENT

Push & Trigger Action Grease Guns	417
Lever Action Grease Guns	417-418
Air & Battery Operated Grease Guns	418
Grease Drum Pumps	419-420
Grease Dispensing Systems	420-422
Control Valves & Booster Guns	422
Grease Gun Couplers & Grease Nipples	422-424
Greasing Accessories	424
Manual Oil Pumps	425-426
Rotary & Lever Action Oil Pumps	426
Air, Battery Operated & Electric Oil Pumps	427
Oil Transfer Kits	428
Oil Control & Suction Guns	428
Rotary & Electric Fluid Pumps	429-430
Diesel Fuel Transfer Pumps	430
Fuel Storage & Dispensing Kits	431
Fuel Filters & Nozzles	431
Plastic Syphon Pumps	432
Diaphragm Pumps	432
Flow Meters	433

LUBRICANTS

Anti-Seize	435-436
Greases	436-437
Engine & Motor Oils	437-440
Hydraulic, Compressor & Tool Oils	441
Maintenance Lubricants & Graphite Powder	442-444
Penetrants	444
Protectants	445
Protective Tapes & Pipe Repair	445-446
Cutting & Grinding Compounds	448

CHEMICALS

Industrial Cleaners & Degreasers	448-450
Precision & Electrical Cleaners	450
Surface Cleaners	451
Paint Thinners & Lighter Fluid	451
Automotive Chemicals	452-454
Non-Destructive Testing	454-455
Repair Putty & Liquids	456-457

GASKETS & PACKING

Rubber Insertion	457
Lagging Tapes & Rope	457
Compression Packing & Gaskets	458-459

ADHESIVES

Instant Adhesives	460
Epoxy Adhesives	460
Bonding Adhesives	461-462
Adhesive Primers	462
Jointing & Chocking Compounds	463-464
Silicone Sealants	464-465
Polyurethane Sealants	465-466
Gasket Sealants	466-467
Threadlockers & Sealants	467-468
Caulking Guns, Applicators & Nozzles	468



GREASE GUN SELECTION GUIDE

GREASE GUNS CAN BE POWERED BY HAND, AIR OR BATTERY.

Hand-powered (or manual) grease guns can either be manufactured with a lever or a trigger grip. There are benefits to each of these, depending on the job at hand and workers' preference. A major variation to grease guns is how they are loaded – by suction fill, cartridge or bulk (requiring a pump).

Lever – Manual

This is the most common type of grease gun and supplies approximately 1.28g of grease per pump and generally has a higher maximum pressure rating.

Trigger – Manual

This variation of the lever-type grease gun allows the user to pump with one hand. It provides approximately 0.86g per pump.

Trigger – Pneumatic

This grease gun uses compressed air directed into the gun via a hose, dispensing grease with each pull of the trigger.

Trigger – Battery

This low-voltage, battery-powered grease gun works similarly to the pneumatic grease gun, but has the benefit of being cordless. Check the output of a grease gun before purchasing.

Grease is an excellent lubricant because it clings to a machine's moving surfaces without easily leaking away. The filling and refilling of grease in grease-lubricated machines must be treated differently than that of oil-lubricated machines. It is important to know the signs of over greasing, as well as under greasing and, how often to reapply. This knowledge can go a long way in extending your machinery's life.

How Output Is Measured

It is common for workshops to have a wide variety of grease gun types, makes and models. This can cause issues with cross contamination and inaccurate knowledge of each grease gun's output per stroke. Grease guns are known to vary in the amount of grease output from 0.5g to more than 3g. This variation depends on factors such as the type, model and age of the grease gun.

ANATOMY OF A GREASE GUN

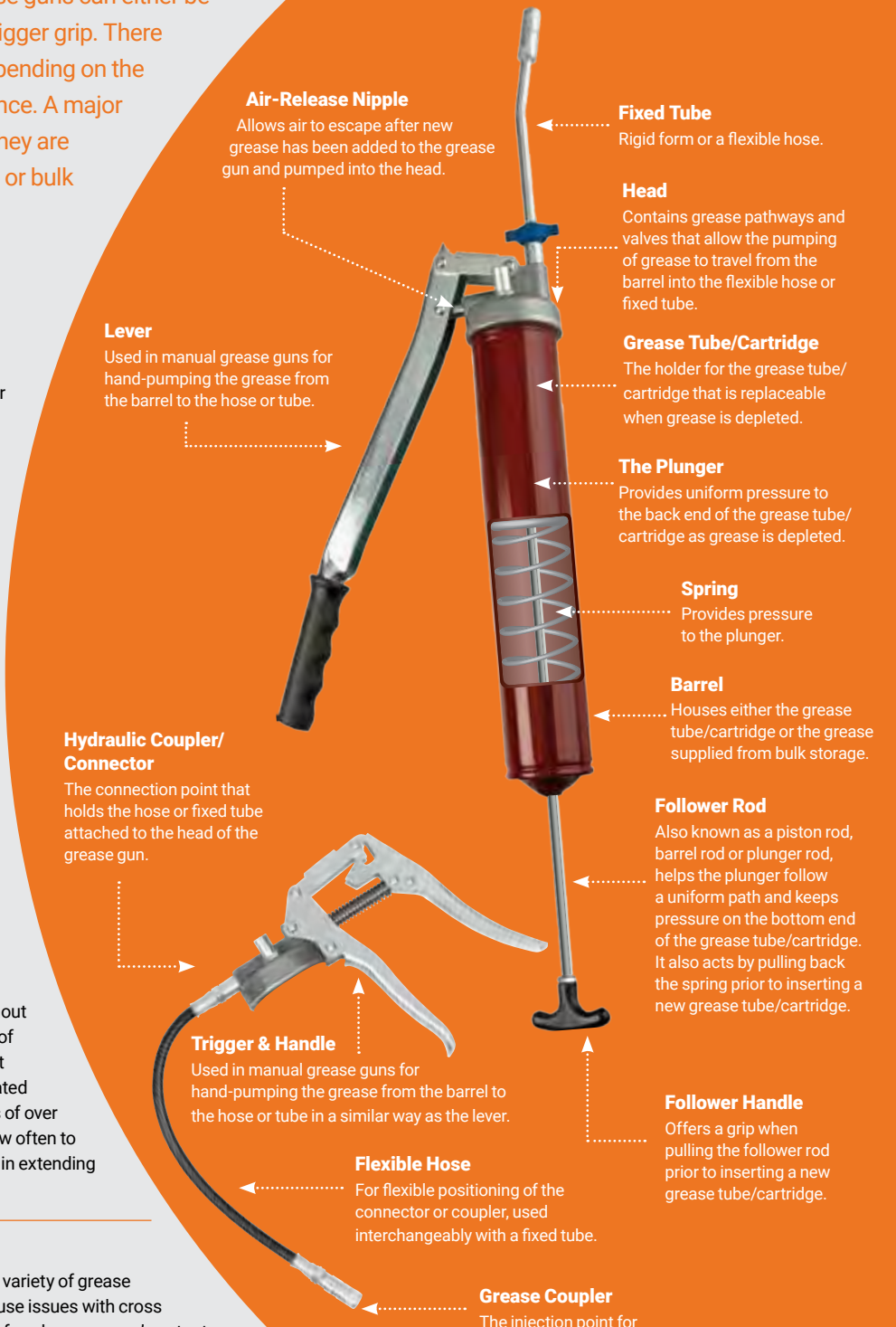

PUSH TYPE GREASE GUN

- For use with bulk grease only
- Steel body construction and compact in size
- Ideal for greasing impact wrenches, lawn mowers, chain saws, trailers, ATVs and other vehicles
- Comes complete with universal connector
- Max. pressure: 1,000psi (69bar)
- Bulk capacity: 30cm³



Item Code	Bishops Code
G6P	68502010

MINI DELUXE PISTOL GREASE GUN

- Convenient one hand operation
- Powder coated finish
- Complete with 4" steel extension and 4 jaw coupler with ball check
- Cartridge capacity: 85g
- Max. pressure: 3,500psi
- Bulk capacity: 120cm³
- 0.40g/stroke
- 1/8" BSPT



Item Code	Bishops Code
G-16/B	68502110

PISTOL GREASE GUN

- Designed for use in confined spaces or where access to grease nipple is restricted
- Heavy duty aluminium die cast head and super strong pistol grip handle
- Robust barrel, heavy duty follower spring, CNC machined grease gun head, and large rolled threads for fast and easy re-loading
- Complete with 300mm flexible hose and professional 4 jaw coupler with ball check
- Head fitted with steel block nut
- Max. pressure: 5,000psi (345bar)
- Cartridge capacity: 450g
- Bulk capacity: 650cm³
- 1/8" BSPT



Item Code	Bishops Code
G4F/PST/B	68502038

VARIO PREMIUM PISTOL GRIP GREASE GUN

- Ergonomic one hand operation
- Unique variable stroke mechanism for both high volume and high pressure applications
- Solid 11mm diameter piston for more grease per stroke
- Drop-resistant pistol assembly
- Robust aluminium die cast grease gun head with bulk filler
- Rolled cylinder threads offer maximum strength
- Suitable for use with NLGI 1, 2 and 3 grease
- Complete with 300mm flexible hose and professional 4 jaw coupler with ball check
- Cartridge capacity: 400g
- Max. pressure: 6,000psi
- Bulk capacity: 500cm³
- 1/8" BSPT



Item Code	Bishops Code
G65F-HP/B	68502039



TRIGGER ACTION GREASE GUN

- Coarse thread on barrel assembly eliminates cross threading during cartridge changeover
 - Unique Twin Lock System eliminates the possibility of dummy lubrication
 - Patented Ever-Flow System enables the gun to be used with thick tacky greases even at low temperatures
 - Lightweight and compact aluminium die cast head assembly
 - Three way loading
 - Delivers up to 1.1g of grease per stroke when on the high volume setting
 - High volume/high pressure setting results in quicker and more effective greasing
 - One hand operation
 - Made in Germany
 - 450g cartridge (700g bulk fill)
 - Max. pressure: 8,500psi
- Includes:**
- 4 jaw coupler and flexible 30mm long extension



Item Code	Bishops Code
660AN	68502036

FLEXIGUN HIGH PRESSURE GREASE GUN

- Pistol grip design for one hand operation
 - Heavy duty 1.6mm thick barrel
 - Suitable for greases up to and including NLGI No.2
 - Max. pressure: 10,000psi
 - Zinc option available to suit underground applications (K29-01-11)
 - Flow rate: 0.68g/stroke
- Includes:**
- KY Supergrip™ coupler
 - 300mm flexible extension



K29-01

Item Code	Description	Suits Cartridge	Bishops Code
K29-01	K29 FLEXIGUN	450g	68502120
K32-01	K32 FLEXIGUN	400g	68502125

450G GREASE GUN & ACCESSORIES KIT

- Delivers up to 1.1cc of grease per stroke on the high volume setting
 - Heavy duty carry case protects all components from dirt and contamination
 - Ideal for greasing difficult to access lube points
 - Convenient on-the-go, on demand greasing solution
 - Max. pressure: 8,500psi (586bar)
- Includes:**
- 660AN Trigger action grease gun (4 year warranty)
 - 30cm Flexible extension
 - 90° Adaptor with coupler
 - Injector needle
 - Needle hose adaptor
 - 3 and 4 jaw couplers



Item Code	Bishops Code
660ANK2	68502045

HEAVY DUTY LEVER ACTION GREASE GUN

- Designed for punishing day-in and day-out heavy industrial applications
- Variable stroke feature built in for use in confined areas
- High tolerance aluminium die cast grease gun head incorporates bulk loader and air bleeder valve
- Robust barrel, heavy duty follower spring, CNC machined grease gun head, large rolled threads for fast and easy re-loading
- Complete with 150mm steel extension and professional 4 jaw coupler with ball check
- Max. pressure: 10,000psi (690bar)
- Cartridge capacity: 450g
- Bulk capacity: 650cm³
- 1/8" BSPT

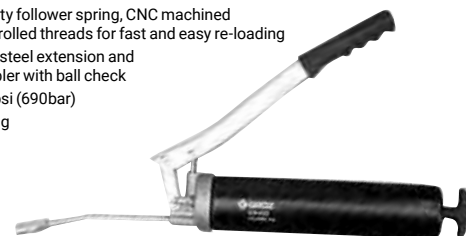

Item Code	Bishops Code
G4R/HD/B	68502042



LEVER, AIR & CORDLESS GREASE GUNS

LEVER ACTION GREASE GUN

- Coarse thread on barrel assembly eliminates cross threading during cartridge changeover
- Unique Twin Lock System eliminates the possibility of dummy lubrication
- Patented Ever-Flow System enables the gun to be used with thick tacky greases even at low temperatures
- Lightweight and compact aluminium die cast head assembly
- Three way loading
- Flow rate: 1.6g/stroke
- High volume, high pressure greasing
- Large diameter piston with a long travel lever
- Cartridge/Bulk Fill: 450g/700g
- Max. Pressure: 12,000psi



Item Code	Bishops Code
600A	68502040

LEVERGUN® HIGH PRESSURE GREASE GUN

- Suitable for cartridges, bulk fill or J3 loading
- Two hand operation
- Heavy duty 1.6mm thick barrel
- Handles up to and including NLGI No.2 greases
- Suits cartridge: 450g
- Max. pressure: 12,000psi
- Flow rate: up to 1.5g/stroke
- Zinc option available to suit underground applications (K45-01-11)

Includes:

- KY Supergrip™ coupler
- 150mm Rigid extension



Item Code	Bishops Code
K45-01	68502130

AIR OPERATED GREASE GUN

- Intermittent action providing grease discharge with every press of trigger
- Ideal for use in factory maintenance, agricultural applications, fleet service or for use on trucks connected to vehicle air brake compressors
- Each gun supplied with a male quick coupler fitting
- Air operating range: 40–120psi (3–8bar)
- Air compressor volume: 1cfm/0.026 cubic metre and above
- Complete with 150mm steel extension and professional 4 jaw coupler
- Pressure ratio: 40:1
- Air inlet: ¼"NPT(F)
- Cartridge capacity: 450g
- Bulk capacity: 650cm³
- Max. pressure: 4,000psi
- ½" BSPT
- 0.90g/shot



Item Code	Bishops Code
PGG/4R/B	68504210

SAMOA 20V CORDLESS GREASE GUN

- Backlit display for real time battery level, grease level and grease metering information
- Red display light warning function
- Rubber supports enable free standing functionality
- Up to 16 cartridges before battery recharge is required
- Battery recharge time: 70mins
- Supplied with 2 x 2.0Ah batteries
- Optional 4.0Ah battery capable of dispensing up to 32 cartridges also available
- Max. working pressure: 7,250psi (500 bar)
- Dual flow rates: 100g/min or 160g/min



630A



Item Code	Cartridge/Bulk Fill
630A	450g/500g
430A	400g/500g

SPECIAL ORDER: PLEASE QUOTE ITEM CODE UPON ORDERING THIS PRODUCT

POWERGUN® 18V CORDLESS GREASE GUN



- Portable battery powered grease gun
- Handles up to and including NLGI No.2 grease
- Suits 450g cartridge or bulk fill
- 18V Li-ion battery
- Max. pressure: 8,500psi
- Flow rate: up to 150g/min (continuous flow)

Includes:

- KY Supergrip™ coupler
- 2 x 3Ah Batteries and charger
- 1m High pressure grease hose



Item Code	Bishops Code
PG450	68502142

GREASE GUN BEST PRACTICE

Calculate the proper amount of grease that is needed for the re-lubrication of bearings based upon the calibrated delivery volume of the selected grease gun.

1

Use a vent plug on the relief port of the bearing to help flush old grease and reduce the risk of too much pressure on the bearing.

2

Use extreme caution when loading grease into the grease gun to ensure that contaminants are not introduced. If using a cartridge, be careful when removing the metal lid so that no metal slivers are introduced into the grease.

3

Make sure the grease gun is clearly marked to identify the grease with which it should be charged. Do not use any type of grease other than that which is identified.

4

Always make sure the dispensing nozzle of the grease gun is clean before using. Pump a small amount of grease out of the dispensing nozzle and then wipe the nozzle off with a clean rag, or lint-free cloth, before attaching it to the grease nipple.

5

Clean the grease nipple of all dirt before attaching the grease gun. Inspect and replace damaged nipples. It is helpful to use grease nipple caps to keep them clean, but still wipe nipples clean before applying grease.

6

Ensure that the proper grease is used at every grease point. Applying the wrong grease can cause an incompatibility problem, which can quickly cause bearing failure. Lubrication points should be clearly identified as to which grease is to be used. This can be done with coloured labels, adhesive dots or paint markers.

7

Grease guns should be stored unpressurised in a clean, cool and dry area and in a horizontal position to help keep the oil from bleeding out of the grease. Grease gun clamps make storage easy and organised. Also, cover the coupler to keep it free from dirt and contaminants.

8

Calibrate grease guns regularly to ensure the proper delivery volume.

EASY PRESSURE CONVERSION CHART

Q: What does 50:1 ratio in air operated grease guns mean?

A: Grease pressure is 50 times air pressure.

psi	KPa	BAR
3,000	20,684.40	206.85
3,500	24,131.80	241.325
4,000	27,579.20	275.8
4,500	31,026.60	310.275
5,000	34,474.00	344.75
5,500	37,921.40	379.225
6,000	41,368.80	413.7
6,500	44,816.20	448.175
7,000	48,263.60	482.65
7,500	51,711.00	517.125
8,000	55,158.40	551.6
8,500	58,605.80	586.075
9,000	62,053.20	620.55
9,500	65,500.60	655.025
10,000	68,947.60	689.5
15,000	103,421.40	1,034.21
20,000	137,895.10	1,378.95
40,000	275,790.30	2,757.90

10:1 RATIO AIR OPERATED GREASE DRUM PUMP

- 10:1 ratio
- Dynamic primer
- Enables mine sites to use grease bins, eliminating the hassles involved in disposing of empty 180kg grease drums
- Easy to move with a forklift so one pump is sufficient for multiple sites
- Compact design assists where space is limited
- 3" male camlock for quick pump fitment
- 4 x 1/4" air motor
- Max. air pressure: 150psi
- Flow rate: 33kg/min



Item Code

7735

SPECIAL ORDER: PLEASE QUOTE ITEM CODE UPON ORDERING THIS PRODUCT

ALEMITE HIGH VOLUME 180KG GREASE PUMP

- 40:1 ratio and delivery lengths up to 50m
- Can service 3 or more hose reels
- Free delivery rate with NLGI2 at 25°C of 5kg/min
- 1/2" NPT (f) air inlet
- 1/2" NPT (f) material outlet
- Idea for mine site and contractor workshops or mobile service vehicles where hazardous and demanding operating conditions exist



Item Code

7785-A5

SPECIAL ORDER: PLEASE QUOTE ITEM CODE UPON ORDERING THIS PRODUCT

K7 MINI LUBE GREASE PUMP

- Provides up to 30 shots of grease with each prime
- Suits 2.5kg grease containers or bulk fill via a J3 transfer pump
- Handles up to and including NLGI No.2 grease
- Max. pressure: 5,000psi (high volume), 10,000psi (mid volume)
- Flow rate: 0.45g/stroke (high pressure), 1.25g/stroke (high volume)



Item Code

K7-01

Bishops Code

68502325

J3 GREASE TRANSFER PUMP

- Quick and easy bulk filling of standard grease guns, air powered grease guns and KT5 and KT6 Minilube containers
 - Delivers up to 54g per stroke
 - Adjustable rigid extension
 - Compatible with grease pail size range: 18-25kg
 - Max. viscosity: up to NLGI No.2
 - Extension hose also available
- Includes:**
- Rigid extension
 - Lid
 - Rubber edged follower plate



Item Code

J3-01

Bishops Code

68502330



GREASE DRUM PUMPS & KITS

PROFESSIONAL GREASE TRANSFER PUMP



- Extra heavy duty construction
- Ideal workshop tool combining economical bulk grease purchasing with the portability of a hand operated grease pump
- Suitable for bulk filling grease guns, as well as transfer of grease from large to small containers
- Solid cast aluminium pump head, ergonomic steel pump handle, solid steel drum cover with lift handle and rubber lined follower plate
- Brass piston rings for minimal wear
- Variable handle setting for increased convenience in use with light and heavy greases
- Fully sealed to prevent contamination
- Comes with female loader adaptor, suitable for 9mm straight loader fittings
- Recommended for use with grease up to and including NLGI 3
- For use with 20kg pails
- Pump length below drum cover: 310mm
- Drum cover diameter: 310mm
- Follower plate dimensions:
Steel end OD: 238mm,
Plate OD: 293mm,
I.P. Plate: 31.4mm



Item Code	Bishops Code
J2-03/BL/B	68502335

AIR OPERATED GREASE 50:1 RATIO PUMP KIT



- World-class industrial high pressure pump with guaranteed performance and hassle-free operation
- Dispenses grease at pressures up to 50 times the air inlet pressure
- Designed to work in tough conditions. Suitable for use in industry, workshop, farm and construction applications
- All metal construction, fully CNC machined with hardened wear resistant moving parts
- Reciprocating piston-operated air motor
- Fitted with strainer at suction tube inlet providing clean grease to the bearing
- Supplied complete with drum cover, rubber lined follower plate, 2.1m of high pressure grease hose, Z swivel and professional grease control valve
- Wetted components made of steel, brass, aluminium and polyurethane
- Recommended for use with light and self-collapsing grease up to NLGI No. 2
- For use with 20kg pails
- Suction tube: 440mm
- Working pressure:
30–150psi (2–10bar)
- Max. air pressure:
150psi (10bar)
- Max. outlet pressure:
7,500psi (500bar)
- Air inlet connection: ¼" BSP(F)
- Pump outlet connection: ¼" BSP(F)
- Air consumption:
230L/min (61gpm)
- Grease output: 1.1kg/min
- Noise level: 81db



Item Code	Bishops Code
GP1/ST/501/BSP	68504240

COMPOSITE AIR OPERATED GREASE RATIO PUMP 50:1



- Operates off most small compressors
- Ideal for applications having continuous need for high pressure grease in industry, workshops and farming
- Zinc construction suitable for mining applications
- 72mm diameter air motor
- Grease strainer at suction tube inlet provides clean grease to the bearing
- Can be used without an air line lubricator
- Pressure release valve prevents both the pump and system against damage created by excessive pressure
- Comes with drum cover, rubber lined follower plate, 2.1m of high pressure hose, Z swivel and professional grease control valve
- Wetted components made of zinc, hard chrome-plated steel, brass, nitrile and polyurethane rubber
- Recommended for use with light and self-collapsing grease up to NLGI No. 2 GRP/501-04
- For use with 50kg pails
- Suction tube: 688mm
- Working pressure:
60–150psi (4–10bar)
- Max. air pressure: 150psi (10bar)
- Max. outlet pressure: 7,500psi (500bar)
- Air inlet: ¼" NPT(F)
- Pump outlet: ¼" NPT(F)
- Air consumption: 270L/min (72gpm)
- Grease output: 460g/min
- Noise level: 85dB
- Drum cover diameter: 381mm
- Follower plate dimensions:
Steel end OD: 322mm
Plate OD: 380mm
Grommet ID: 27.5mm



Item Code	Bishops Code
GRP/501/04	68504250

P3 POWERLUBE™ AIR OPERATED GREASE PUMP KIT



- 50:1 ratio grease drum pump
- Air operated system
- Non-corroding air motor
- Low air consumption
- Available as pump only or as a kit
- Suitable for underground applications
- Australian manufactured
- Max. pressure (with B2 booster gun): 10,000psi
- Flow rate: 460g/min
- Kit Includes:**
- P3001 Pump unit
- KY Supergrip™ coupler
- Lid and rubber edged follower plate
- B2 Booster gun and ZSB high pressure swivel
- High pressure grease hose (6mm x 4m)



Item Code	Bishops Code
P3-01C	68504220

P8 MAXILUBE™ AIR OPERATED 180KG GREASE KIT



- 50:1 Ratio air operated pump
- 2.5mm x 6mm ID delivery hose
- Min. air pressure: 60psi
- Max. air pressure: 150psi
- Output: 460g/min (at pump)
- Air inlet: ¼" NPT (F)
- Pump outlet: ¼" NPT (F)
- Kit Includes:**
- Pump unit
- Lid and follower
- B2 Booster gun



Item Code	Bishops Code
P8-11	68504225

P58 MAXILUBE HEAVY DUTY AIR OPERATED GREASE PUMP



- Heavy duty construction providing reliable long service life
- High-quality components to ensure reliable operation in the harshest environments
- Large silencer that is incorporated into the aluminium alloy pump body to prevent icing and less noise
- Quick grease line pressure recovery provides instant greasing
- Large pump suitable for long grease line delivery
- Air consumption: 23.5cfm
- Pressure ratio: 58:1
- Compatible with 180kg (400lb) drums
- Air pressure operating range: 60–150psi (413k–1,034kPa)
- Max. fluid outlet pressure: 8,700psi (59,900kPa)
- Max. free flow delivery rate: 6kg/min (13lb/min) (@120psi pressure, 20°C)
- Noise level: 85 dB(A) (@120 psi)
- Air inlet size: 1/4" BSPT
- Fluid outlet size: 3/8" BSPT
- Grease viscosity: Up to NLGI No.2
- Supplied with lid and follower, hose and B2 Booster Gun



Item Code

P58PGLF-01

SPECIAL ORDER: PLEASE QUOTE ITEM CODE UPON ORDERING THIS PRODUCT

SAMOA 20KG AIR OPERATED GREASE KIT



- 55:1 ratio air motor
- Steel, NBR and PTFE wetted parts
- Integrated inlet foot valve filter protects the pump from possible foreign particle contamination
- Handles greases up to NLGI2
- Quiet operation due to exhaust muffler
- Max. pressure: 7,950psi (550bar)
- Air pressure operating range: 22–140psi (0–1.5bar)
- Max. flow rate: 540g/min @ 100psi

Includes:

- 55:1 ratio pump
- Drum cover
- Follower plate
- 4m Hose
- Z swivel and control valve
- Carry handle



Item Code

424170

Bishops Code

68504200

SAMOA 180KG AIR OPERATED GREASE KIT



- 55:1 ratio
- Integral filter eliminates the chance of pump tube contamination
- Lightweight, ergonomic cast alloy grease control valve
- Ideal for busy workshops where greasing is undertaken all day, every day
- Suits 180kg grease containers
- Max. pressure: 7,950psi
- Flow rate: up to 600g/min
- Drum not included



Item Code

428262

SPECIAL ORDER: PLEASE QUOTE ITEM CODE UPON ORDERING THIS PRODUCT

BUCKET GREASER



- Volume grease pump designed for quick effortless greasing in applications requiring everyday lubrication such as greasing of excavators and other earth moving equipment, agricultural equipment, automotive applications etc.
- Delivers up to 9g of grease per stroke
- Fully CNC machined to very close tolerances
- Wetted components made from steel, aluminium, brass and nitrile rubber
- Recommended for use with grease up to and including NLGI No. 3
- 10kg capacity
- Max. pressure: 4,000psi (275bar)



Item Code

VGP/10A

Bishops Code

68502320

PORTABLE GREASING SYSTEM



- Fully portable and single person operation
- Designed for workshop environments, site applications, pick-up trucks, tractors and earth moving equipment
- Foot operated pump
- A single charge provides 30 shots of grease
- Aluminium die cast super gun has high pressure and volume settings
- High pressure setting dispenses 0.45g of grease in each shot at 10,000psi
- High volume setting dispenses 1.25g per shot
- Pump assembly is fully sealed to prevent contamination
- Complete with drum cover, rubber lined follower plate, super gun with steel extension and coupler
- Also includes 5kg plastic grease bucket and a 1.5m premium high pressure hose
- Wetted components made from aluminium, steel, brass, polyurethane and nitrile rubber
- For use with grease up to and including NLGI No. 2
- Pump length below drum cover: 197mm
- Drum cover diameter: 216mm
- Follow plate dimensions: Steel end OD: 171mm, plate OD: 206mm



Item Code

GS/5

Bishops Code

68502315

HIGH PRESSURE FOOT OPERATED GREASE PUMP



- High pressure portable grease pump for quick effortless greasing in everyday lubrication such as greasing of excavators and other earth moving equipment, agricultural equipment, automotive etc.
- Hands free operation; pump operates using the foot lever, hich greatly reduces effort and allows high pressure greasing with highest comfort
- Can be operated by hand when under low machinery
- Moving parts create wave action in grease, removing air pockets and eliminating the use of a follower plate
- Delivers over 2g of grease per stroke
- Suitable for use with NLGI 1, 2 and 3 greases
- Wetted components made from steel and nitrile rubber
- 10kg capacity
- Max. pressure: 8,700psi (600bar)



Item Code

FOP/10A

Bishops Code

68502322



GREASE DISPENSING SYSTEMS, VALVES, GUNS & COUPLERS

AUTOMATIC GREASE LUBRICATION SYSTEM

- Easy to install automatic lubrication system featuring high performance, reliability and rugged design
- High pressure output can service grease points within a radius of up to 30m
- Uses precision progressive dividers to ensure accurate and reliable lubricant distribution to all connected grease points, with built in indication if any grease point refuses to take grease
- Suitable for transport, construction, mining, agriculture, manufacturing, food and beverage and waste management
- Complete kit to service 20 grease points automatically

Includes:

- Beka Max 24V DC pump station with onboard timer and 4kg grease reservoir
- 70m Grease filled hose
- Reusable hose ends
- Compression fittings and adaptors
- Nuts and bolts
- Cable ties
- Protective hose wrapping



Item Code

ALS-20

SPECIAL ORDER: PLEASE QUOTE ITEM CODE UPON ORDERING THIS PRODUCT

CONNECTORS, ADAPTORS & COUPLERS

Some grease guns come with a standard connection adaptor such as a hydraulic coupler, but there are variations depending on the application.

The standard hydraulic coupler is most commonly used and the most applicable.

A 90° adaptor is ideal for fittings in confined areas that require a 90° bend.

A needle-end adaptor provides a thin, precise amount of grease for tight places

A three-way swivel coupler offers a variety of locking positions for different applications.

Grease Fittings

Grease fittings or grease nipples are the lubrication point where the grease connector is attached. A hydraulic grease fitting can be positioned upright or angled. The button-head fitting is ideal for good coupler engagement when large volumes of grease are being used. A flush-type grease fitting is preferred when working in a confined space. The pressure-relief vent fitting helps prevent higher pressures that could lead to damaged seals.

Flexible Hose vs. Fixed Tube

When deciding whether to use a flexible hose or a fixed tube, the machine's grease-fitting type and ease of location should be factored in, as well as the type of grease gun being used. A hard-to-reach location would benefit from a flexible tube. While a lever-style grease gun requires both hands to pump the grease and would be easier to use with a fixed-tube.

ALEMITE GREASE CONTROL VALVE

- Heavy duty grease control valve capable of continuous flow or preset measured shots provides greater lubrication options
- Rigid nozzle
- Ideal for use with pneumatic, hydraulic and electrically operated grease pumps and kits
- Inlet: 1/4" NPT (F)



Item Code

6320-3

Bishops Code

68504270

GREASE CONTROL VALVE

- Robust design
- Standard duty steel and non aluminium construction
- Made of steel so ideal for underground coal use
- Rigid extension with 3 jaw coupler
- Inlet: 1/4" BSP(f)
- Max. pressure rating: 7,000psi (483bar)
- Manufactured in China



Item Code

66880N

Bishops Code

86410798

B2 BOOSTER GUN

- Used for high pressure delivery with any air powered grease pump
- Boosts grease line pressure with a press of the trigger
- Increases the inlet grease pressure to overcome line resistance or nipple blockages
- Includes high pressure ZSB grease swivel as standard
- Inlet: 1/4" NPT (F)



Item Code

B2-01

Bishops Code

68502150

QUICK RELEASE GREASE GUN COUPLERS

- Works with all grease gun types
- Fits all metric and SAE specification grease nipples
- Four hardened steel spring jaws, resilient under high pressure
- Durable nitrile rubber seal for longevity
- Sliding sleeve locks the quick release coupler onto the nipple
- Max. pressure: 10,000psi



Item Code

A14512

Thread

1/8" BSP

Length

90mm

Bishops Code

68510045

GREASE GUN COUPLERS & NIPPLE SETS

GREASE GUN COUPLERS

- Compact design for greater accessibility
- Quick and easy release mechanism enabling one handed operation – Load & Lube
- Superior safety internal pressure relief mechanism
- Max. pressure: 10,000psi (68,900kPa)



KYPLUS-01

Item Code	Inlet Size	Bishops Code
KYPLUS-01	1/8" BSP(F)	68510025
KYPLUS-02	1/8" NPT(F)	*KYPLUS-02

* - SPECIAL ORDER: PLEASE QUOTE ITEM CODE UPON ORDERING THIS PRODUCT

BUTTON HEAD GREASE GUN COUPLERS

- Die cast coupler body and button head
- Conveniently slides over standard button head grease nipples
- Ensures reliable and dependable lubrication of heavy machinery and equipment
- 1/8" BSP thread



14506

14507

Item Code	Description
14506	Standard Button Head Pull On Coupler
14507	Push on Button Head Coupler With Built-In Swivel

SPECIAL ORDER: PLEASE QUOTE ITEM CODE UPON ORDERING THIS PRODUCT

BUTTON HEAD COUPLER

- Fixed hook-on
- Zinc die cast body
- Conveniently slide over the face of the button head fitting
- Metal seal increases resistance to wear
- Pressure: 3,000psi (207 bar)
- Suits button head fitting: 5/8" (16mm)
- Thread: 1/8" BSPT



Item Code	Bishops Code
HOC/1/B	68510030

HYDRAULIC GREASE GUN COUPLERS

- Industrial quality coupler for standard hydraulic grease nipples
- Easy on/off
- 1/8" BSPF thread
- Max. pressure: 12,000psi (827bar)
- Manufactured in Germany



14513

14514

Item Code	Description
14514	3 Jaw Hydraulic Grease Gun Coupler
14513	4 Jaw Hydraulic Grease Gun Coupler

SPECIAL ORDER: PLEASE QUOTE ITEM CODE UPON ORDERING THIS PRODUCT

HEAVY DUTY HYDRAULIC COUPLERS



- Suitable for hand operated and air operated grease guns
- Hardened body with double wall thickness to withstand high pressure without deformation
- Fully hardened spring steel jaws
- Hexagonal nut for easy tightening
- Fitted with ball check valve
- 3 and 4 jaw construction
- Pressure: 10,000psi (690 bar)



Item Code	Bishops Code
HC/12/4/B	68510020

HYDRAULIC SWIVEL COUPLER



- Provides effective lubrication of difficult and hard to reach grease fittings
- Swivels on a full 360° rotation and locks at any 45° position
- Fully hardened jaws for extended service life
- Hardened body and joints to withstand high pressure without deformation
- Zinc plated finish
- Spring loaded ball check valve
- 3 jaw construction
- Pressure: 7,000psi (483 bar)
- Thread: 1/8" BSPT



Item Code	Bishops Code
HC/SW/3/B	68510040

80 PIECE GREASE NIPPLE SET – METRIC



Includes:

- M6 x 1 thread: 20 x Straight, 10 x 90°
- M8 x 1 thread: 15 x Straight, 10 x 90°
- M10 x 1 thread: 15 x Straight, 10 x 90°



Item Code	Bishops Code
GFT/KIT/M-80	68514920

110 PIECE GREASE NIPPLE SET – METRIC



Includes:

- M6 x 1 thread: 30 x Straight, 20 x 90°
- M8 x 1 thread: 20 x Straight, 10 x 90°
- M10 x 1 thread: 20 x Straight, 10 x 90°



Item Code	Bishops Code
GFT/KIT/M-110	68514940



GREASE NIPPLE SETS, THREAD TESTER, EXTENSIONS & TOOLS

80 PIECE GREASE NIPPLE SET – SAE



Includes:

- 1/8"-27 PTF thread: 25 x Straight, 10 x 45°, 10 x 90°
- 1/4"-28 SAE-LT thread: 15 x Straight, 10 x 45°, 10 x 90°



Item Code	Bishops Code
GFT/KIT/SAE-80	68514910

110 PIECE GREASE NIPPLE SET – SAE



Includes:

- 1/8"-27 PTF thread: 30 x Straight, 15 x 45°, 15 x 90°
- 1/4"-28 SAE-LT thread: 20 x Straight, 15 x 45°, 15 x 90°



Item Code	Bishops Code
GFT/KIT/SAE-110	68514930

110 PIECE GREASE NIPPLE GRAB KITS – METRIC & IMPERIAL

- Comes in hard plastic case for handy storage
- Kits include a variety of straight, 45° and 90° grease nipples



Description	Bishops Code
Metric Grease Nipple Kit – Includes 6–10mm Dia.	40420060
Imperial Grease Nipple Kit – Includes 1/4"–3/8" Dia.	40420059

GREASE NIPPLE KITS – METRIC & IMPERIAL



- Straight and angled nipples



CA108

Item Code	Description	Kit Size	Bishops Code
CA109	Metric – 12 Sizes: M6, M8 & M10 Dia. – Fine & Coarse	105 Pieces	40410160
CA108	Imperial – 15 Sizes: UNF, BSF, BSP & NPT Threads	113 Pieces	40410150
CA2415	Metric & Imperial – 20 Sizes: M6, M8 & M10 Dia. (Metric), BSF, BSP, UNF, NPT & GAS Threads (Imperial)	415 Pieces	*CA2415

* – SPECIAL ORDER: PLEASE QUOTE ITEM CODE UPON ORDERING THIS PRODUCT

GREASE NIPPLE THREAD TESTER



- A handy tool for quickly and easily identifying the thread type of your grease nipples and other fittings
- Made from aluminium, this low cost compact and lightweight utility tool can be stored in a handy place ready for use
- Comes complete with all the common thread sizes including BSP, NPT, UNF, BSW and Metric
- Extra holes in top corners for hanging in common areas for easy access

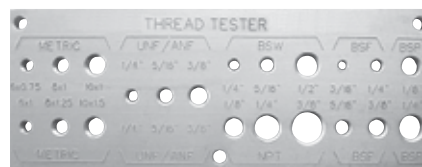

Item Code	Bishops Code
6000	68514945

HEAVY DUTY GREASE HOSES



- Polyamide inner tubing with polyurethane sheathing, reinforced diagonally in highly tear resistant polyester
- Heavy duty zinc plated end connections hydraulically crimped to the hose
- Ideal for use in cold weather
- Rolled threads for extra strength
- 1/8" BSPT



Item Code	Length	I.D	O.D.	Working Pressure	Burst Pressure	Bishops Code
GHC-8/B	200mm	3.6mm	8.5mm	3,500psi	11,600psi	68512020
GHC/HP-20/B	500mm	4.1mm	10.8mm	5,800psi	13,775psi	68512045

GREASE GUN EXTENSIONS



- Industrial quality, genuinely high pressure and high flexibility
- Polyamide hose maximises product life
- Manufactured in Germany
- 1/8" BSP threads
- Min. burst pressure: 14,500psi



Item Code	Length	Bishops Code
14550	200mm	68512010
14551	300mm	68512030
14552	450mm	68512040

EASY OUT TOOLS



- Removes worn and broken grease fittings as well as re-taps holes for installing new grease fittings
- Suitable for both straight and angled fittings
- Size available to suit almost all threaded fittings



Item Code	Description	Bishops Code
ESO/1	Small – Hex Size: 7–9mm (5/16"–3/8") Tap Re-Threads: 1/4"–28"	68590510
ESO/2	Large – Hex Size: 9–11mm (3/8"–7/16") Tap Re-Threads: 1/2"–27"	68590520



HOW TO SELECT A DRUM OR TANK PUMP

A drum or tank pump is an instrument placed on the upper opening of a drum, barrel or tank and used to remove and transfer the liquid inside. What pump you require will depend on its intended application. There are many variations of drum pumps, so Bishops are making it easy, letting you know what pump to look for to best suit your needs.

What fluid are you moving?

Each drum pump is made of various materials to suit specified fluids such as grease, oil and chemicals. Make sure you also pay attention to the viscosity of the liquid as many drum pumps can only move light fluids. The recommended fluids for each pump are easy to find in the product heading.

What mechanism suits your needs?

Down Stroke pumps, also known as piston pumps, are actioned by the downward action of a hand operated pump positioned on the top of the drum. The downward movement increases pressure in the centre chamber, positively displacing liquids and forcing them out of the discharge hose end.

Rotary pumps work by turning a handle positioned on the side of the pump. Fluid is drawn into and forced out of spaces created by moving parts. The discharge flow of a rotary pump is smooth and is typically suitable for light fluids.

Lever Action pumps work with the manoeuvring of a hand operated lever up and down, positioned at the top of the drum pump. This action pulls fluid from the drum and out the discharge hose end. This method provides a higher output per stroke than simple syphons and allows for movement of medium viscosity fluids (SAE140).

Air Operated pumps are not manually operated, they work with the connection of an air compressor, moving fluid in a similar way to a down stroke pump. The non-electrical feed reduces the risk of igniting any flammable gases or liquids. Air operated pumps are less laborious than their manual counterparts making them suitable for everyday use.

Syphon causes a liquid to flow upward with no pump, powered by the pull of gravity, then discharges at a level lower than the surface of the reservoir from which it came. Simple plastic syphon pumps use air pressure to start the flow, but given this simple technology, the flow is not steady and the receiving container must be below the surface level of the drum. These pumps are light and convenient for transport and suitable for pumping fluids such as petrol.

Battery Powered, as the name suggests, are operated by battery with no manual labour required. This makes them suitable for everyday use. Automatic drum pumps do cost a premium in comparison to manual varieties.

What size drum/IBC do you have?

Each drum or tank pump suits a specific size of drum or IBC. Take note of what size drum you have and make sure that the pump is compatible.

Can't find the drum or tank pump that you need?
Ask Bishops!

88 SERIES HAND OPERATED OIL DRUM PUMPS

- Drainback nozzle holster ensures excess oil ends up back in the drum and not on workshop floor
- UV stabilised hose ensures a long service life
- Delivers 110ml on the downstroke
- 8828N2 Includes an extendable down tube sleeve and two extra adaptors which enables the pump to be suitable to use with a range of 20L drums



8828N2

Item Code	Description	Bishops Code
8826N	ATF Oil Drum Pump	*8826N
8828N2	Gear Oil Drum Pump	68575106

* - SPECIAL ORDER: PLEASE QUOTE ITEM CODE UPON ORDERING THIS PRODUCT

99 SERIES SPRING OPERATED OIL & ATF DRUM PUMPS

- Spring operated pump and lever action control valve allows for semi-automatic oil transfer
- Unique swiveling pump head assembly reduces the chance of hose kinks
- Robust zinc pump head assembly and ground shafts with O-ring seals
- Fitted with drain back nozzle holster
- Max. viscosity: 100



9928

Item Code	Description	Flow Rate
9926	ATF Drum Pump With Hose & Filter - 20L	330ml/Stroke
9976	ATF Drum Pump With Hose & Filter - 60L	500ml/Stroke
9928	Gear & Engine Oil Drum Pump With Hose - 20L	330ml/Stroke
9978	Gear & Engine Oil Drum Pump With Hose - 60L	500ml/Stroke

SPECIAL ORDER: PLEASE QUOTE ITEM CODE UPON ORDERING THIS PRODUCT

EZEE FLO OIL PUMPS

- Versatile hand lift pump with plastic pull out Rieke® spout engineered for trouble free use on 20L containers
- Heavy duty steel suction tube, with the pump head made from high density polyethylene
- Interchangeable bung adaptors
- Pump length can be extended by 19mm for use on high depth containers, by conveniently sliding on a special plastic extension at the suction end
- Wetted components made from steel, polyethylene, derlin, PVC* (*Only on pumps supplied with hose)
- Recommended for use with engine oils, gear oils, diesel, 100% antifreeze and light fuel oil
- Do not use with water based and other corrosive media
- Pump length: 325mm



EZEF/10

Item Code	Description	Bishops Code
EZF/9	With 48" Flexible Hose & Spout	68570020
EZF/10	With Rigid Steel Spout	68570040



MANUAL, ROTARY & LEVER OIL PUMPS

OIL PISTON PUMP

- An easy to use, highly convenient, single person operation oil pump that dispenses oils with a simple press of the trigger
- Single hand operation, requires no continuous lever/rotary pumping action
- Spring loaded design that charges the pump for continuous dispensing of media with a single charge
- A single charge gives 500ml of output
- All metal construction with built in 2" male threads into the pump head
- Pump head incorporates drain back port to minimise wastage and spillage of over flown media
- Supplied complete with 5' PVC hose fitted with an oil control gun
- Designed for use with 60L drum
- Steel, aluminium, zinc, brass, NBR, polypropylene and PVC wetted components
- Recommended for use with engine and gear oils up to SAE 140, automatic transmission fluids



Item Code

SLP/60

Bishops Code

68570085

PLASTIC ROTARY OIL PUMP

- Designed for dispensing oil based fluids
- Polypropylene body, rotor and veins
- Viton shaft seal and steel hardware
- Strainer protects the pump from contaminants
- Comes with threaded polypropylene suction tube and 2" bung adaptor
- Wetted components made from polypropylene, viton and steel
- Recommended for use with oil based media, antifreeze etc.
- Do not use with water based media, acids, chemicals, solvents, lacquer, gasoline
- Delivers 5L per 20 turns
- Drum capacity: 50-205L



Item Code

ERP/01

Bishops Code

68570320

PISTON PUMP

- Polypropylene plastic drum pump with stainless steel rod
- Suitable for light oils, paraffin, alcohols, water and water-based chemicals
- For use with 60-205L drums
- Flow rate: 400ml/stroke



Bishops Code

68570160

FRONT ACTION BARREL PUMP

- Unique front action operation
- Makes pumping easy and allows the pump to be used on barrels placed in corners and other inaccessible areas
- Heavy duty aluminium die cast pump head incorporates 2" bung threads
- Brass piston rings for increased life
- No riveted parts, allows 100% serviceability
- Built-in nozzle holder for convenient storage of discharge hose
- Includes 1.8m PVC nitrile delivery hose with metal nozzle, spring and hose clamp
- Comes complete with telescopic suction tube for use on 50-205L drums
- Delivers 250ml per stroke
- Wetted components made from steel, aluminium, brass, NBR and PVC nitrile
- Recommended for use with diesel, kerosene, heating oils, motor oils, lubricating oils (up to SAE 90), and other non-corrosive media
- Do not use with water based media, antifreeze, solvents, acids, and gasoline etc.



Item Code

A2H/BL

Bishops Code

68570140

PLASTIC LEVER OIL PUMP

- Convenient and comfortable design to pump thick oils without excessive fatigue
- Versatile for use with water based media, high viscosity oils, agricultural and select chemicals
- Built-In 2" bung adaptor and anti-siphon vent cap
- Lock nut allows for pump position to be easily adjusted
- Complete with suction tube and flexible corrugated discharge hose
- Wetted components made from polyacetal, polypropylene, polyethylene, PVC and viton
- Should only be used with non-flammable liquids and must never be used for fuel transfer or with thinners and solvents
- Delivers 500ml per stroke
- Drum capacity: 50-205L
- Hose: 2m x 3/4" ID



Item Code

PLP/02

Bishops Code

68570060

GET MORE AT BISHOPS



OIL JUGS & POURERS

Page 394

5:1 COMPOSITE AIR OPERATED OIL PUMP

- Dispenses oils up to five times the pressure as the air inlet
- Suits most small compressors as small as 0.08m³
- Commonly used in workshops, farming, construction machinery or as a part of a mobile oil system
- Reciprocating piston-operated 72mm diameter air motor
- Non-corroding air motor design, no air line lubricator needed
- Built-in pressure relief valve
- Dual oil inlet threads, 1" NPT(F) and 1" UNEF(F)
- Ideal for use over distances up to 50m
- Comes with 2" bung nut and 1" telescopic suction tube
- Wetted components made from aluminium, zinc, steel, brass, nitrile and polyurethane rubber
- Recommended for use with oils (to SAE 140), ATF, diesel, kerosene and soft self collapsing grease
- Air inlet: 1/4" NPT (F)
- Pump outlet: 1/2" NPT (F)
- Working pressure: 60-150psi (4-10 bar)
- Max. oil pressure: 145psi
- Max. air pressure: 150psi (10 bar)
- Air consumption: 270L/min
- Discharge: 15L/min



Item Code

ORP/51T/N

Bishops Code

68575110

SAMOA 3:1 RATIO AIR OPERATED OIL PUMP

- For medium size systems involving hose reels and metered oil dispensing guns without simultaneous operation
- Suitable for 60L or 205L drums
- Air inlet pressure: 40-140psi
- Air inlet: 1/4" BSB (F)
- Outlet: 1/2" BSP (F)
- Max. viscosity: 450
- Max. pressure: 420psi
- Max. flow rate: 35L/min



Item Code

354120

Bishops Code

68575104

ALEMITE 5:1 RATIO AIR OPERATED OIL STUB PUMP

- 5:1 ratio
- Can service up to 3 reels
- Double acting reciprocating model
- Spool valve design ensures fewer pump failures
- Modular design maximises operating time
- Air inlet/outlet: 1/2" NPT (F)
- Max. viscosity: 550
- Max. pressure: 700psi
- Flow rate: up to 28L/min



Item Code

9968

SPECIAL ORDER: PLEASE QUOTE ITEM CODE UPON ORDERING THIS PRODUCT

12V BATTERY POWERED OIL TANK PUMP

- Piusi DC self-priming gear type oil transfer pumps complete with integrated bypass valve
- Suitable for use with lubricants up to 600 centistokes
- Ideal for high use applications in areas where 240V power and compressed air are not available
- Noise level: Less than 65dB
- Inlet: 3/4" BSP (F)
- Outlet: 3/4" BSP (F)
- Max. working pressure: 70psi
- Max. flow rate: 10L/min



Item Code

309010

SPECIAL ORDER: PLEASE QUOTE ITEM CODE UPON ORDERING THIS PRODUCT

3:1 AIR OPERATED OIL RATIO PUMP

- Designed to work in tough conditions and are ideal for use in industry, workshop, farm, construction or as part of the mobile oil system
- All metal construction, fully CNC machined with hardened wear resistant moving parts
- Reciprocating piston operated 63mm diameter
- Air motor stub pumps are supplied with non-return valve threaded 1" (F) for use on the bottom of the suction tube
- Pumps are single acting with discharge up to 14L/min
- Ideal for use with medium to high viscosity oils (up to SAE 130) for transferring over short distances (up to 30m)
- Wetted components made from steel, brass, aluminium, high nitrile rubber, polyurethane and turcite
- Air consumption: 230L/min
- Max. oil pressure: 115psi



Item Code

OP/T3/31B/BSP

Bishops Code

68575100

240V ELECTRIC OIL VANE PUMP

- Piusi 240V vane type pump with sintered steel rotor and resin vanes
- Suitable for the transfer of engine, gear, diff and hydraulic oils
- Inlet: 3/4" BSP
- Outlet: 3/4" BSP
- Continuously rated with pressures up to 85psi
- Max. flow rate: 25L/min



Item Code

334900

Bishops Code

74930088



HOW TO CHOOSE AN OIL DISPENSING SYSTEM

What fluid are you moving?

Make sure you pay attention to the viscosity of the liquid that you plan to move. As a general rule the higher the pump ratio, the thicker the oil it can move. All oil dispensing systems are easily identifiable by their product title.

High or low pressure?

Taking liquid viscosity out of the equation, generally the higher the pressure the higher the flow rate. High pressure dispensing systems dispense oil at a greater rate.

Air operated or electric?

Air Operated

Air pumps work with the connection of an air compressor, moving fluid in a similar way to a down stroke pump. The non-electrical feed reduces the risk of igniting any flammable gases or liquids.

Battery Powered

As the name suggests, battery operated systems are operated by battery, with no manual labour required. This makes them suitable for everyday use. Battery power does cost a premium in comparison to air operated varieties.

SAMOA AIR OPERATED IBC OIL TRANSFER KIT

- Eliminates costly and time consuming disposal of 205L drums
- Refillable, reusable, mobile and fully transportable
- Dual pedestal hose reel provides a long service life
- Electronic oil meter powered by replaceable AAA batteries
- Max. flow rate: 18L/min

Includes:

- 3:1 ratio pump
- Hose reel and 10m hose
- Top mounting bracket
- Electronic oil meter



Item Code

454695

SPECIAL ORDER: PLEASE QUOTE ITEM CODE UPON ORDERING THIS PRODUCT

OIL CONTROL GUN

- For use with air operated oil pumps up to 6:1 pressure ratio
- Gun dispenses by simple press of the trigger
- Built-in safety and continuous flow lever, and swivel threaded at inlet for easy manoeuvrability
- Slim construction
- Wetted components made from steel, nylon, stainless steel and viton
- Recommended for use with oil, gear lube and ATF
- Do not use with water based media, gasoline etc.
- Working temperature range: -10°C to 60°C
- Inlet: ½" NPT (F)
- Max. pressure: 870psi (60bar)



Item Code

OGY/S/1-2R/N

Bishops Code

68550108

OIL CONTROL GUN WITH MECHANICAL METER



- Robust shock resistant design with aluminium die cast body and a soft shroud encasing the meter
- 6 digit accumulative totaliser (max. 999,999L) and single reset button
- Works on oval gear technology for highest accuracy and repeatability
- Two outlet positions for in-line and 90° dispensing
- Swivel with strainer built at the gun inlet
- Supplied complete with rigid steel extension fitted with automatic non-drip nozzle
- Recommended for use with engine oil, diesel oil, ATF, antifreeze, anti-boil and other oils up to SAE 140
- Wetted components made from aluminium, acetal, steel, nitrile rubber
- Inlet: ½" BSPT (F)
- Operating temperature: 0°C to 50°C
- Max. pressure: 1,500psi (100bar)
- Flow range: 1-30L/min (0.26-8g/min)



Item Code

HG/40R/B

Bishops Code

68550110

OIL SUCTION GUN



- A rugged transfer gun designed for transferring gear oils in and out of gear boxes, transfer cases and differentials
- Deluxe lip seal provides maximum suction
- Steel barrel in premium powder coated finish
- Fully serviceable
- No priming required
- Suitable for use with non-corrosive liquids
- Comes with 300mm flexible vinyl hose
- Capacity: 500ml



Item Code

SG/11-BL

Bishops Code

68502030

OIL SUCTION GUNS

- Ideal for draining and filling of diffs, gear boxes and engine blocks
- A double 'V' packing ensures that oil does not leak through the rear of the gun
- Hose length: 290mm
- Max. viscosity: 500



21041

Item Code

21040

21041

Capacity

530ml

770ml

SPECIAL ORDER: PLEASE QUOTE ITEM CODE UPON ORDERING THIS PRODUCT

HIGH SPEED FUEL & OIL ROTARY PUMP

- Aluminium alloy drum pump
- Suitable for fuels and low viscosity oils
- Has both clockwise and counter-clockwise operation
- Flow rate: 1L/stroke
- For use with 60–205L drums



Item Code	Bishops Code
RP99ZB	68570360

HIGH SPEED ROTARY PUMP WITH FUEL FILTER

- Commonly used for dispensing or transferring low viscosity and non-corrosive petroleum based fluids, such as petrol, diesel, kerosene, lube, fuel, machine oil, and more
- For use with 60–205L drums
- Maximum viscosity: 500 SSU (or SAE 30)
- Flow rate: 1L/stroke
- Comes with filter and hose assembly



Item Code	Bishops Code
RP99ZF	68570365

QUART/LITRE STROKE PUMP

- Heavy duty industrial pump
- Provides an economical way of dispensing exact quantities of media per stroke
- Extremely useful in applications requiring metered delivery
- Operates on a precision rack and pinion mechanism
- Built in 2" bung adaptor
- Comes with telescopic suction tube
- Spring loaded drain back tube
- Lockable handle for security while not in use
- Lock nut for positioning the pump outlet in any direction
- Wetted components made from steel, aluminium, nitrile rubber and acetal
- Recommended for use with gear and lube oil, petroleum based media, diesel and kerosene
- Do not use with water based and other corrosive fluids
- Delivers 1L/1 quart per stroke
- Barrel capacity: 50–205L



Item Code	Bishops Code
QSP/01	68570350

SPOUT FOR ROTARY PUMP

- Used for high speed rotary pumps to attach inline filter
- 1" BSP x 1" NPT
- 90° elbow



Item Code	Bishops Code
	68595200

CAST IRON FUEL & OIL ROTARY BARREL PUMP



- Features dual directional operation which allows the pump to both empty and refill containers
- Extremely heavy duty
- Sturdy cast iron body with precisely machined cast iron vanes for better draw and smoother delivery
- Comes with suction tube, 2" cast iron bung nut and discharge spout
- Wetted components made from steel, cast iron and NBR/Viton
- Recommended for use with diesel, kerosene, heating oils, motor oils, lubricating oils (up to SAE 90), and other non-corrosive media
- Do not use with water based media, antifreeze, solvents, acids and gasoline
- Delivers 5L per 20 turns
- Barrel capacity: 50–205L
- Pump inlet: 1"
- Weight: 6.6kg



Item Code	Bishops Code
GNB-25T/SPL	68570340

ROTARY BOOSTER PUMP 3:1



- Provides high volume fuel dispensing
- For every complete handle turn, the rotor turns 3 times
- Ideal for construction sites, workshops, aviation, farms/ranches, boats and more
- Die cast aluminium construction
- Sintered gear driven die cast zinc rotor and vanes
- 1.8m delivery hose with metal nozzle
- Wetted components made from aluminium, zinc, steel, NBR and PVC nitrile
- Recommended for use with gasoline, diesel fuel, kerosene and lubricating oils (up to SAE 30)
- Do not use with corrosive liquids, solvents, acids and alkalis
- Delivers 205L in 3 minutes
- Drum capacity: 50–205L



Item Code	Bishops Code
RB/3H	68570380

ROTARY CHEMICAL PUMP



- Designed for use in applications where a cast iron or steel barrel pump cannot be used
- Glass filled polypropylene body with Ryton veins
- Viton seals and stainless steel hardware
- Strainer protects the pump from contaminants
- Comes with threaded polypropylene suction tube and two 2" bung adaptors for use on both plastic and metal drums
- Wetted components made from polypropylene, Ryton, viton and stainless steel
- Recommended for use with water based media, antifreeze, Urea, Adblue, DEF, Benzene, Detergents, Glycerine, acids, chemicals and all petroleum based products
- Do not use with acetone, lacquer, mineral oils, solvents and turpentine
- Delivers 5L per 20 turns
- Drum capacity: 50–205L



Item Code	Bishops Code
PRP/01	68570325



ELECTRIC FUEL PUMPS & FUEL TRANSFER PRODUCTS

DUAL DIRECTION TRANSFER GUN



- Draws in and pumps out liquid in a single stroke
- Easy and safe answer to fluid transfer, especially useful in transferring media unsafe for body contact
- Non-denting heavy aluminium gun body
- Aluminium suction head and piston with Viton piston rings
- Complete with 1.2m vinyl hose on each valve
- Wetted components made from aluminium, brass, viton, PVC
- Suitable for use with fuel oils, mineral oils, synthetic and biological oils, petrol, cooling liquids, water, antifreeze, spirits and brake fluids

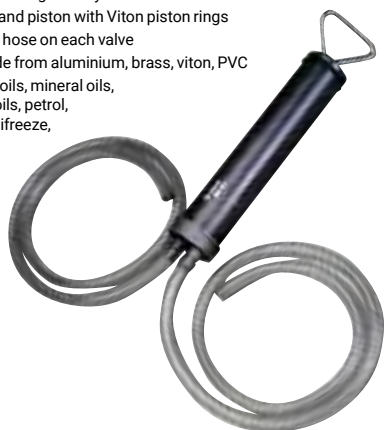

Item Code

SG/20

Bishops Code

68502032

HEAVY DUTY HIGH FLOW ELECTRIC FUEL PUMP



- Heavy duty industrial grade high flow fuel pump designed for heavy duty usage in agricultural, construction, automotive and industrial applications
- Rain and weather proof for tough outdoor use
- Lightweight yet strong, non-corroding
- Aluminium die cast construction geared pump design using precision sintered metal gears
- Geared construction makes the pump tolerant to contaminants in fuel; in addition to offering tremendous suction and minimal noise
- Wetted components made from aluminium, steel, cast iron, nylon, NBR, zinc, viton, polypropylene and PVC
- Recommended for use with gasoline, diesel, E15 fuel, kerosene, bio diesel (B20)
- Duty cycle: 30min on/off
- Flow rate: 20L/min



Item Code

FPM/12/HF

Bishops Code

68575820

220V REFUELLING KIT



- Heavy duty industrial grade fuel pump designed for every day use in agricultural, construction, automotive and industrial applications
 - Rain and weather proof for tough outdoor use
 - Lightweight, yet strong non-corroding aluminium die cast construction
 - Geared pump design using precision sintered metal gears
 - Geared construction makes the pump tolerant to contaminants in fuel
 - Tremendous suction and minimal noise
 - Explosion Proof Motor: 1/8hp, 220V AC, 50/60 Hz.
 - Duty cycle: 30min on, 30min off
 - 1A
 - Tank adaptor: 2" Threaded
 - Inlet: 1" NPT
 - Outlet: 3/4" NPT
 - Max. flow rate: 49L/min
- Includes:**
- 3/4" Manual dispensing nozzle with swivel
 - Internal bypass valve
 - Steel suction pipe
 - 3/4" x 12ft Anti-static hose



Item Code

FPM 220

Bishops Code

68575822

DIESEL REFUELLING KITS



- Ideal for intermittent diesel refuelling applications
 - Self priming rotary vane pump includes a built-in bypass
 - Duty cycle: 30min on/off
 - Max. head capacity: 15m
 - Suction capacity: 2m
 - Max. flow rate: 50L/min
- Includes:**
- 4m Anti-static fuel delivery hose
 - 2m Battery cable
 - Stainless steel and brass fuel filter



52000

Item Code	Power	Nozzle
52000	12V	Manual
52001	24V	Manual

SPECIAL ORDER: PLEASE QUOTE ITEM CODE UPON ORDERING THIS PRODUCT

240V DIESEL FUEL TANK VANE PUMP



- Piusi vane type pump with sintered steel rotor and acetalic resin vanes
- Weather resistant cast iron, paint finished pump housing
- Built-in 100µm filter is easily accessible for cleaning
- 240V continuous running operation
- Ideal for diesel fuel transfer out of bulk tanks where 240V power is available
- Inlet/outlet: 1" BSP
- Max. flow rate: 72L/min



Item Code

732000

SPECIAL ORDER: PLEASE QUOTE ITEM CODE UPON ORDERING THIS PRODUCT

HIGH VOLUME DIESEL FUEL PUMPS



- Vane type pump with sintered steel rotor and acetylic resin vanes
- Sturdy cast iron construction
- Thermal motor overload protection
- 240V continuous running operation
- Suitable for the transfer of diesel fuel



326000

Item Code	Size	Max. Flow Rate
326000	1"	100L/min
321000	2"	550L/min

SPECIAL ORDER: PLEASE QUOTE ITEM CODE UPON ORDERING THIS PRODUCT

PIUSI IN-LINE DIESEL TRANSFER PUMPS



- Self-priming 12V electric pump with on/off switch
- Sturdy handle for convenient portability
- Duty cycle: 30 mins on/off
- BSP(F) inlet/outlet connections
- Max. working pressure: 22psi (1.5bar)
- Flow rate: up to 50L/min



52050

Item Code	Power
52050	12V
52051	24V

SPECIAL ORDER: PLEASE QUOTE ITEM CODE UPON ORDERING THIS PRODUCT

LOCKABLE DIESEL FUEL STORAGE & DISPENSING KITS

- Heavy duty, robust polyethylene tank
- Patented Italian manufactured pump ensures trouble-free operation
- Lockable lid for security and protection of components
- Forklift lift points and tie-down capabilities
- Tank baffles aid vehicle stability
- Built in nozzle holster
- Suitable for all makes of single and twin cab utes
- Pump covered by a two year warranty
- Flow rates of up to 50L/min

Standard Kit Includes:

- 12V Pump
- 4m Anti-static fuel delivery hose
- 2m Battery cables
- Automatic nozzle
- L80080PA/L100080PA/L120080PA supplied with hi-flow pump



Item Code	Capacity	Size
L10040PA	100L	691(w) x 716(d) x 567(h)mm
L20040PA	200L	1,000(w) x 716(d) x 567(h)mm
L45040PA	450L	1,000(w) x 883(d) x 850(h)mm
L60040PA	600L	1,000(w) x 1,109(d) x 850(h)mm
L80080PA	800L	1,700(w) x 1,000(d) x 870(h)mm
L100080PA	1,000L	1,700(w) x 1,000(d) x 1,025(h)mm
L120080PA	1,200L	1,700(w) x 1,000(d) x 1,190(h)mm

* - SPECIAL ORDER: PLEASE QUOTE ITEM CODE UPON ORDERING THIS PRODUCT

DIESEL FUEL STORAGE & DISPENSING KITS

- Heavy duty polyethylene tank cannot dent, scratch or corrode
- Tank baffles aid vehicle stability
- Pallet lift points and recesses for tie down straps on the tank aids handling and installation

Includes:

- 12V pump
- 4m anti-static fuel delivery hose
- 2m battery cables
- Dispensing nozzle



Item Code	Capacity	Max. Flow Rate	Nozzle	Tank Dimensions	Bishops Code
40049GA	400L	49L/min	Auto	800(w) x 1,630(d) x 635(h)mm	*40049GA
40068PA	400L	79L/min	Auto	800(w) x 1,630(d) x 635(h)mm	*40068PA
40080P	400L	80L/min	Manual	800(w) x 1,630(d) x 635(h)mm	*40080P
60080P	600L	80L/min	Manual	800(w) x 2,400(l) x 635(h)mm	62022103

* - SPECIAL ORDER: PLEASE QUOTE ITEM CODE UPON ORDERING THIS PRODUCT

FUEL FILTER

- Suitable for use with gravity or hand, air and electric drum pumps
- Features a 10µm fuel filter element, a drain cock and replaceable clear plastic bowl
- Replacement elements readily available
- Inlet/outlet: 1" BSP
- Manufactured in the USA



Item Code	Bishops Code
FA2	74974252

MANUAL FUEL & PETROLEUM NOZZLES

- Plastic shroud protects the trigger assembly and the users hands
- Can be locked in the open position
- Hanging clip helps to reduce the possibility of diesel fuel contamination and nozzle damage
- Suitable for gravity feed applications and those including pressures of up to 140psi
- Ideal for farm tank applications
- Inlet: 1" BSP swivel
- Max. flow rate: 150L/min



Item Code	Description	Bishops Code
52007	Manual Diesel Fuel Nozzle	68550020
52155	Manual Petroleum Nozzle (ULP)	*52155

* - SPECIAL ORDER: PLEASE QUOTE ITEM CODE UPON ORDERING THIS PRODUCT

MANUAL FUEL CONTROL NOZZLE



- For use with electric fuel pumps and gravity feed applications
- All metal aluminium construction
- Fitted with continuous flow switch and hose swivel at inlet for increased manoeuvrability and convenience
- Designed for minimal back pressure and reduction in flow
- For use with diesel, kerosene and petrol
- Wetted components are made from aluminium, steel, nylon, nitrile rubber
- Spout: 160mm
- Inlet: 1" BSP(F)
- Outlet OD: 25mm



Item Code	Bishops Code
FCN/S/0-1/0-1/BSP	68550010

AUTOMATIC SHUT-OFF DIESEL NOZZLES

- Automatically cuts off when a fuel tank is full
- Swivel inlet included
- Suitable for applications involving an electric diesel transfer pump only
- Inlet: 1" BSP (F)
- Working pressure: 26psi (not suitable for gravity feed applications)



Item Code	Flow Rate
51037	60L/min
51039	120L/min

* - SPECIAL ORDER: PLEASE QUOTE ITEM CODE UPON ORDERING THIS PRODUCT

AUTOMATIC DIESEL FUEL NOZZLE

- Automatically cuts off when a fuel tank is full
- Can operate with flow rates up to 280L/min
- Suitable for applications involving a pump only
- Swivel included
- Inlet: 1 1/2" BSP(f)



Item Code	Bishops Code
52039	62022108



SYPHON & DIAPHRAGM PUMPS

PLASTIC SYPHON PUMP

- Quick action pump, easily fills or empties kerosene, light oils, gasoline and various water-based solvents
- Air vent controls siphoning
- Pumps to higher levels and syphons to lower levels
- Polyethylene wetted parts
- Max. fluid temperature: 60°C
- Maximum viscosity: 500 SSU
- Mounting: 2" MNPT Bung adaptor for 55, 115 and 205L containers
- Suction tube: 3/8" ID, 1" OD
- Suction tube length: 0.86m
- Discharge tube: 15/16" ID, 1 1/16" OD
- Discharge length: 1.2m
- Flow rate: 26.5L/min



Item Code
Bishops Code
68570240

PLASTIC SYPHON PUMP

- Easy to use, polyethylene pumps syphon liquids to lower levels than the height at which the pump is installed
- Easy to prime and start within 6-7 strokes
- Pump requires no further operation and keeps working in auto position, emptying the media being pumped
- All pumps are equipped with a vent cap on top, opening the cap stops the discharge
- Supplied complete with flexible corrugated discharge tube
- Recommended for use with water-based fluids, detergents, waxes, soaps, antifreeze, some mild acids, and other liquids compatible with pump materials of construction
- Polyethylene wetted components
- 1 1/2" bung
- Suits 5-20L pails
- 551mm discharge hose
- Flow rate: 6.5L/min



Item Code
Bishops Code
SPH/1 68570220

HAND OPERATED SYPHON CHEMICAL & SOLVENT DRUM PUMP

- Polypropylene pump head and PVC pickup tube
- Includes 875mm long pickup tube and 1.2m of hose
- Suitable for low viscosity fluids
- Suitable for 60L or 205L drums
- Max. flow rate: 20L/min



Item Code
225
SPECIAL ORDER: PLEASE QUOTE ITEM CODE UPON ORDERING THIS PRODUCT

AIR OPERATED DIAPHRAGM PUMPS

- Aluminium body and hytrel diaphragms
- Rugged bolted construction eliminates leaks and simplifies post maintenance reassembly
- Suitable for diesel fuel, gear oil, engine oil, waste oil, antifreeze and waste water
- Optimal stroke length maximises diaphragm life and performance whilst minimising pump downtime and maintenance costs



ALE-25BAH



Item Code	Size	Max. Flow Rate
ALE-25BAH	1"	160L/min
ALE-20BAH	3/4"	120L/min

SPECIAL ORDER: PLEASE QUOTE ITEM CODE UPON ORDERING THIS PRODUCT

3/4" AIR OPERATED CHEMICAL DIAPHRAGM PUMP

- Stainless steel body and Teflon diaphragms
- Suitable for use with solids up to 2mm (OD)
- Suitable for the transfer of MEK (methylene ketone), hydrochloric acid up to 20% concentration, phosphoric acid, methanol, paint thinners and water
- Inlet/outlet: 3/4" BSP (F)
- Max. flow rate: 100L/min



Item Code
ALE-20BST
SPECIAL ORDER: PLEASE QUOTE ITEM CODE UPON ORDERING THIS PRODUCT

AIR OPERATED DIAPHRAGM PUMPS

- For large volume transfer
- Suitable for cleaning pits or sumps
- Self-priming pump for high suction lift



68575218

Item Code	Casing	Inlet/Outlet	Flow Rate	Max. Air Consumption	Bishops Code
AODD/1-2/BAH/N	Aluminium	1/2"	50L/min	450L/min	68575228
AODD/3-4/BAH/N	Aluminium	3/4"	110L/min	1,200L/min	68575218
AODD/3-4/BPS/N	Polypropylene	3/4"	110L/min	1,200L/min	68575224

DIAPHRAGM BILGE PUMP

- Hand operated
- Mountable on most surfaces
- Made from Acetal, PU, stainless steel and PVC components
- Suitable for use with water, sea water, diesel, kerosene, gasoline, and a variety of oils
- Flow rate: 16.6L/min



Item Code
DPP/20
Bishops Code
68570200

DOUBLE DIAPHRAGM FUEL TRANSFER PUMP

- Ideal for use where compressed air and power is not easily available, such as farms, ranches and construction sites
- Stainless steel piston and fuel resistant hi-nitrile rubber diaphragm
- Includes a 2" die cast bung adaptor and extra heavy duty steel handle with security locking latch
- Complete with telescopic suction tube with non-return valve
- Wetted components made from aluminium, steel, stainless steel, poly acetal and NBR
- Recommended for use with gasoline, diesel fuel, fuel oil, motor oil and other light petroleum products
- Do not use with corrosive liquids, solvents, acids, alkalis etc.
- Delivers 800ml per stroke
- Drum capacity: 50-205L

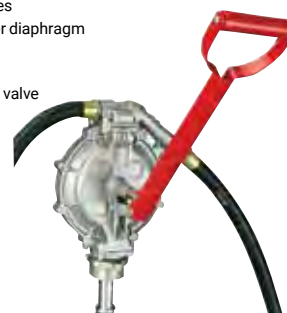

Item Code
DPP/1
Bishops Code
86412085

MECHANICAL & ELECTRICAL FLOW METERS

Flow meters monitor the flow of oil from a pump or metering device to the lubrication point. Flow meters are available in both mechanical and electrical configurations.

Mechanical

The most common mechanical flow meters are inserted into a pipe and use a turbine, wheel or paddle to measure velocity. Once the velocity is known, the volumetric flow can be calculated by knowing the cross section area of the pipe where they are installed. Other mechanical varieties follow the same basic principles. For a correct reading the pipe needs to be at capacity.



Electrical

Electrical flow meters work with the same principle as the mechanical, but are differentiated by their electric display and battery operation. As with the mechanical, for a correct reading the pipe must be at capacity.



MECHANICAL FUEL METER



- Extremely compact, yet easy to read
- Robust aluminium die construction
- 3 port design which allow the meter to be fitted in-line or with the inlet and outlet ports at right angle
- Nutating disc mechanism offers high tolerance to fuel contamination
- For use with electric fuel pumps or gravity flow (with a minimum gravity head of 4")
- Register cap can be easily removed and rotated to every 90° orientation for display reading
- Easy user re-calibration
- Works with both fuels and oils
- Recommended for use with diesel, gasoline, biodiesel, low to medium viscosity oils
- Do not use with water based media
- Wetted components made from aluminium, poly butylene terephthalate (PBT), viton and stainless steel



Item Code	Bishops Code
FM-100/0-1/BSP	68520030

MECHANICAL FUEL METERS

- Suitable for the metering of petrol, diesel fuel and kerosene
- Suitable for gravity feed or pump applications
- Field calibration possible
- Accurate between flow rates of 20–120L/min
- Accuracy: ±1.0%
- Inlet/outlet: 1" BSP (F)
- Max. working pressure: 145psi



51008

Item Code	Description	Max. Batch Total	Bishops Code
51008	3 Digit Mechanical Diesel Meter	9,999L	68520020
51007	4 Digit Mechanical Diesel Meter	999L	*51007

* - SPECIAL ORDER: PLEASE QUOTE ITEM CODE UPON ORDERING THIS PRODUCT

DIESEL FLOW METER

- Metal case
- Precision
- Suit petrol and diesel MFM/M10
- Inlet/outlet: 1" BSP



Item Code	Bishops Code
MFM/M10/B	68520035

MECHANICAL DIESEL FUEL METER



- 4-digit resettable totaliser
- 8-digit non-resettable totaliser
- Register can be rotated
- Nutating disc
- Inlet/outlet: 1" BSP
- Max. working pressure: 49psi (3.5bar)
- Flow rate: 20–120L/min



Item Code	Bishops Code
L-FM25	68520000

MECHANICAL DIESEL METER



- Suitable for diesel, kerosene, ULP and light oils and gravity flow applications
- Inlet/outlet: 1" BSP (F)
- Max. working pressure: 345kPa (50psi)
- Flow range: 20–120L/min for accuracy of ±1%



Item Code	Bishops Code
AMFM	68520005

DIGITAL DIESEL FLOW METER



- 6 digit reset total
- 6 digit non-reset total
- Field calibration capability
- Suitable for diesel, kerosene and coolants
- Inlet/outlet: 1" BSP
- Maximum working pressure: 50psi (3.5bar)



Item Code	Bishops Code
ADTFM	68520010

ELECTRONIC OIL METER



- High pressure positive displacement meter suitable for in-line and end of line applications
- Oval gear mechanism for optimum accuracy
- Electronic display using two 1.5V batteries
- Robust aluminium die cast construction
- Measures in litres, quarts, pints and gallons
- Easy user re-calibration
- Wetted components made from aluminium, stainless steel, nitrile rubber and POM
- Recommended for use with oils with viscosity up to 5,000cSt, diesel, biodiesel
- Do not use with water based media, gasoline etc.
- Threads: ½" BSP(F)



Item Code	Bishops Code
OM-20/1-2/BSP	68520040



LUBRICATION LIFECYCLE OF PARTS & ASSEMBLIES

Lubricants are specialised chemicals designed to reduce friction and protect your parts and assemblies from the effects of their wearing environment. Flip through the following pages to find the right lubricant for the job. Can't find what you're looking for? Contact Bishops!



1

Preparation Lubricants

Lubricant applications commence here. These lubricants are applied to parts prior to or during assembly or simply before these parts are used for the first time. They penetrate the surface, often leaving a dry lubricating film that prevents the part from seizing and protects it from galling and corrosion.



2

Oils & Greases

Similar to preparation lubricants, oils and greases are applied prior to operation. These are designed for complete assemblies such as engines, transmissions, gear boxes and axles. Additives are used to allow these to operate effectively in a wide variety of environments.



5

Penetrants

Penetrants are specialised lubricants used to release parts and fittings to enable disassembly, and to clean or clear parts and assemblies from the effects of their wearing environment, typically rust or corrosion.

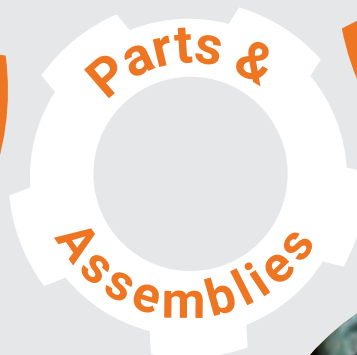

3

Protectants

Protectants are another specialised lubricant. Whilst all lubricants are protective by design, protectants are designed to be applied to operating assemblies either for storage, extended life purposes or at the conclusion of the maintenance process prior to the assembly going back into operation.



4

Maintenance Lubricants

These lubricants are general purpose in nature and applied to parts and assemblies that have already been run-in or operated. They can be used to clean, coat, protect and generally maintain the integrity and smooth operation of parts and assemblies.

Jump straight to the lifecycle stage of the part or assembly you're lubricating to find the product you need to get the job done.



Cutting & Grinding Lubricants

Another specialised lubricant, not part of the typical part and assembly lifecycle, used to assist and enhance the effectiveness of the cutting and grinding process and to protect and preserve the cutting tool being used.

PREPARATION LUBRICANTS

You'll find two common preparation lubricants; anti-seize and dry film.

Anti-Seize is a grease compound that contains suspended additives, metal and non-metal based, applied to metal parts and assemblies to provide long-term lubrication and protection against rust, corrosion, galling and seizing.

Dry Film or pre-assembly lubricant, resembles your standard general purpose lubricant, however they are designed to protect components from the effects of their wearing environment, including rust and corrosion.

TYPES OF Anti-Seize

There are four main types of anti-seize compound:

Copper Based anti-seize is suitable for steel with the exception of stainless steel, where it will chemically react to eventually cause corrosion and cracking.

Nickel Based anti-seize is suitable for steel including stainless steel. However, it is classified as a carcinogen, so it is not to be handled in workshops without protection.

Silver Grade anti-seize is aluminium based. It is ideal for static to slow moving assemblies working under heavy load in high temperature.

Metal-Free anti-seize is suited for all applications, generally free of hazardous particles, making them non-toxic and more environmentally friendly.

We've laid out the most popular anti-seize products by these types.



It's easy with Bishops!

GET MORE AT BISHOPS



HAND CLEANERS

Page 399

COPPER EZE GREASE

- Benton-based anti-seize grease
- Contains micro-size copper, zinc oxide and other synthetic base oil
- Resists temperatures up to 1,093°C
- Rust and corrosion protection in severe environments
- Prevents galling
- NLGI 1.5



Size	Bishops Code
100g	70521625

STOP-SEIZE COPPER

- Heavy duty, high temperature water-repelling compound that protects against rust, corrosion and seizure of metal parts
- To use with valve assemblies, conveyors, flange gaskets and studs, piping, bushings, compressors, boiler fittings and heat exchanges
- Anti-seize performance up to 1,090°C
- Size: 500g



Item Code	Bishops Code
D19020	32410220

STOP-SEIZE NICKEL

- Heavy duty, high temperature water repelling compound containing suspended nickel that resists corrosion and galling
- Recommended for use with stainless steel and other alloys where a copper based product would be unsuitable
- Anti-seize performance up to 1,400°C
- Size: 500g



Item Code	Bishops Code
D19030	32410230

LOCTITE 771 NICKEL ANTI-SEIZE



- Copper-free formulation with extreme chemical resistance, recommended for stainless steel and other metal fittings
- Prevents corrosion, seizing and galling in harsh chemical environments at temperatures to 1,315°C
- Recommended for chemical plants and oil refineries, water and sewage plants, environments where a 'clean' inert lubricant is needed
- Size: 500g



Item Code	Bishops Code
39163	32414114



GENERAL PURPOSE, BEARING & HIGH PRESSURE GREASES

TYPE A GREASE

LANOTEC

- A food grade lubricant and anti-seize
- Anti-seize for threaded rod, shackles, nuts and bolts
- Lubricant for rubber hoses, O-rings, linkages, pivot pins and bushes
- Rubber grease, non perishing
- Assembly lube
- Moisture proofing of multi-pin plugs and connectors, non-conductive to 70kV
- Stops galling of stainless steel and aluminium
- Stops electrolysis due to dissimilar metal contact di-electric grease



Item Code	Size	Bishops Code
GS\0235	235ml	*GS\0235
GS\250T	250ml Tube	32003138
GS\0500	500ml	32003140
GS\0001	1L	32003145
GS\0004	4L	32003150
GS\0020	20L	32003155

* - SPECIAL ORDER: PLEASE QUOTE ITEM CODE UPON ORDERING THIS PRODUCT

PBR RUBBER GREASE

- Premium quality general purpose grease
- Non-harmful clay based
- Contains castor oil
- Compatible with natural and synthetic rubbers
- NLGI 2



Size	Bishops Code
100g	70520010
500g	70521615

HIGH TEMP WHEEL BEARING GREASE

- High temperature and extreme pressure grease
- Lithium complex soap thickener
- Tacky formula
- General chassis grease applications in the automotive industry
- Lead and chlorine free
- Blue



Size	Bishops Code
450g	70521510
2.5kg	70521515
20kg	70521520

GRADE YOUR GREASE

Grease is a shear-thinning fluid with high viscosity used on mechanisms which are not lubricated frequently or when synthetic lubricant will not stay in place.

Whilst grease is highly viscous, under shear, the viscosity is lowered to that of the base oil allowing it to lubricate the surrounding area.

The National Lubricating Grease Institute (NLGI) provides a standard for greases to help grade and understand their viscosity levels.

NLGI Grade	Worked Penetration ($\frac{1}{10}$ mm)	Appearance	Consistency
0	445-475	Fluid	Cooking Oil
0	400-430	Semi-Fluid	Apple Sauce
0	355-385	Very Soft	Brown Mustard
1	310-340	Soft	Tomato Paste
2	265-295	"Normal" Grease	Peanut Butter
3	220-250	Firm	Veg. Shortening
4	175-205	Very Firm	Frozen Yogurt
5	130-160	Hard	Smooth Pate
6	85-115	Very Hard	Cheddar Cheese

MOLYGREASE EP 3%

- All purpose high temperature grease
- Lithium soap base
- NLGI 2
- Protects against shock loads
- Rust and corrosion protection
- Black



Size	Bishops Code
450g	70521585
2.5kg	70521590
20kg	70521595

EXTREME PRESSURE GREASE

- General purpose coloured grease
- Suitable for most applications in the automotive industry
- High level protection against shock loads
- Rust and corrosion protection
- Red



Size	Bishops Code
450g	70521535
2.5kg	70521540
20kg	70521545

INDGREASE LITHIUM EP 0 GREASE

- Lithium based mineral lubricant
- Multi-purpose semi-fluid grease
- Reduced wear under high or shock loads
- Rust and corrosion protection
- Lead, chlorine, nitrite and extract free



Size	Bishops Code
20kg	70521530

INDGREASE 100LX EP2

- High melting point lithium complex grease
- For the most demanding grease applications
- Provides extreme pressure and anti-wear protection
- Long life protection
- Lead, chlorine, nitrite and extract free



Size	Bishops Code
450g	70521610

MARINE GREASE

- High temperature lithium complex grease
- Excellent protection in salt water environments
- Rust and corrosion protection
- Lead and chlorine free
- Tacky formula



Size	Bishops Code
450g	70521500

POWER SPORTS GREASE

- Water resistant high temperature grease
- Suitable for use in outdoor applications including motorcycling, automotive and marine activities
- Rust and corrosion protection
- Protection against shock loads
- Tacky formula
- Lead and chlorine free



Size	Bishops Code
100g	70521620

MC-2ST 2-STROKE ENGINE OIL

- Fully and semi synthetic 2-stroke oils
- Extends engine life and keeps engines clean
- Low ash formulation
- Environmentally friendly
- Size: 1L



70520550



70520560

Description	Bishops Code
Semi-Synthetic Engine Oil	70520550
Fully Synthetic Engine Oil	70520560

HI-PER 2-STROKE ENGINE OIL

- Suitable for us in motorcycles, mopeds and scooters
- Also suits gardening equipment such as chainsaws, lawn mowers and more
- Extends engine and spark plug life
- Low smoke and low ash formulation



Size	Bishops Code
1L	70520565
20L	70520575

2 STROKE OIL

- Specially developed lubricant for air-cooled two stroke engines
- Can be mixed with leaded or unleaded petrol
- The formulation utilises a mixed additive system to ensure a minimal ash deposit formation
- Contains diluent, making it easy to mix with fuel
- Controls corrosion excellently
- Minimal ring wear and piston scuffing
- Cleans burning, assisting in maintaining cleaner combustion chambers, ports and mufflers



STIHL

Item Code	Size	Bishops Code
0781 319 8401	100ml	70090018
0781 319 8411	1L	70090028
0781 319 8433	5L	70090030

GET MORE AT BISHOPS ▶

CHAINSAWS

Page 152





OIL GRADING WHAT DOES IT MEAN?

Single Grade engine oils are made without additives and perform best when either at high or low temperatures depending on the product specifications. As with multi grade oils, the weight is determined by the viscosity and is the only number listed (e.g. 15W). Cold temperature oils list a 'W' at the end of the number. High temperature oils are tested at 100°C and are not given a 'W' designation after the number.

Multi Grade engine oils feature additives to improve their performance in hot and cold temperatures. The numbering system uses viscosity grades labelled 'weight' to grade different oils. In a multi grade specification, the first number (e.g. 15W) refers to the viscosity at low temperature. The second number (e.g. 40) refers to the viscosity at 100°C.

Bishops stock a huge range of oils to help cater to any kind of job. Can't find what you're looking for below?

Give Bishops a call!

SEMI-SYNTHETIC 10W-40 ENGINE OIL

- Complete engine protection
- Full zinc anti-wear Additive package for complete engine wear protection
- API Licensed for quality guarantee assurance
- Latest engine oil specification technology for
- Maximum wear protection
- Minimum sludge formation
- Reduced piston deposits
- Better high temperature protection than SAE 10W-30 grade oils
- Catalyst and oxygen sensor friendly
- Petrol and diesel compatible engine oil



Size	Bishops Code
1L	70520230
5L	70520235

PRO EXTRA 10W-40 SEMI-SYNTHETIC ENGINE OIL

- API licensed for quality assurance
- Full zinc anti-wear additive package for ultimate engine wear protection
- Maximises wear protection
- Minimises sludge formation
- Reduces piston deposits
- Reduces oil consumption and maintains oil pressure
- Catalytic converter compatible.
- Ideal for light duty diesel engines



Size	Bishops Code
20L	70520250

MC-4ST ENGINE OIL 100% PAO & ESTER

- Fully synthetic engine oil with 100% PAO and Ester base oils
- Suitable for most 4-stroke road, sports and dirt bikes
- Ideal for competition race teams
- Maximum wear protection
- Size: 1L



Description	Bishops Code
10W-40 Engine Oil	70520770
15W-50 Engine Oil	70520780

PREMIUM MINERAL 15W-40 ENGINE OIL

- API licensed for quality guarantee assurance
- Latest API SN plus oil specification technology
- Maximum wear protection
- Minimum sludge formation
- Reduced piston deposits
- Enhanced LSPI (low speed pre-ignition) protection
- Reduced turbo charger deposits
- Improved oxidation and deposit control, aeration and fuel economy over SN grade oils
- Blended using premium hydrocracked base oils for heat resistance and high performance
- Shear stable VI improvers help maintain oil viscosity
- Catalyst and oxygen sensor friendly
- Suitable for use in rotary engines



Size	Bishops Code
5L	70520265

PENRITE CONVOY MFD 15W-40 MINERAL DIESEL ENGINE OIL

- Convoy MFD is a high quality, mineral, SAE 15W-40, mid ash diesel engine oil formulated with high quality additives and premium hydrocracked mineral base oils
- Excellent protection of engine parts
- Resists oil thickening
- Shear stable viscosity modifier maintains oil viscosity in service
- Mid ash formulation controls combustion chamber deposits
- Can be used in mixed fleets, reducing the chance of misapplication



Size	Bishops Code
20L	70520285
205L	70520290

PENRITE CONVOY DFX 15W-40 PREMIUM MINERAL DIESEL ENGINE OIL

- Excellent protection of engine parts
- Resists oil thickening
- Shear stable viscosity modifier maintains oil viscosity in service
- Mid ash formulation controls combustion chamber deposits
- Can be used in mixed fleets, reducing chance of misapplication and minimising inventory



Size	Bishops Code
5L	70520205
20L	70520215
205L	70520220

PREMIUM MINERAL 20W-50 ENGINE OIL

- Latest oil specification technology
- Maximum wear protection
- Minimum sludge formation
- Reduced piston deposits
- Shear stable VI improvers help maintain oil viscosity
- Petrol and diesel suitability
- Catalyst and oxygen sensor friendly
- Blended using premium hydrocracked base oils for heat resistance and high performance
- Suitable for use in rotary engines



Size	Bishops Code
5L	70520275

PRO 20 20W-50 MINERAL ENGINE OIL

- Can be used where SJ, SL, SG or SF oils were recommended
- Superior performance to older specification engine oils
- FULL ZINC anti-wear additive package for ultimate engine wear protection
- Reduces oil consumption and maintains oil pressure
- Catalytic converter compatible
- Ideal for light duty diesel engines



Size	Bishops Code
20L	70520280

MOTORCYCLE FORK OILS

- Fully synthetic motorcycle oils
- Very high viscosity index fluid
- Protects system from wear
- Excellent low temperature properties
- Size: 1L



Description	Bishops Code
MC 5W Fork Oil	70520755
MC 10W Fork Oil	70520760

MARINE 2-STROKE ENGINE OIL

- Semi-synthetic marine engine oil
- Ideal for all water cooled 2-stroke outboard engines
- Minimises plug fouling, ring sticking and port blockages
- Low smoke
- Anti-seize and anti-scuff



Size	Bishops Code
1L	70520655
5L	70520665
20L	70520670

10W-30 MARINE 4-STROKE ENGINE OIL

- Mineral based marine engine oil
- Suitable for use in 4-stroke outboard, inboard and stern drive engines



Size	Bishops Code
5L	70520675
20L	70520680

10W-40 MARINE 4-STROKE ENGINE OIL

- Semi-synthetic marine engine oil
- Suitable for use on all 4-stroke outboard engines where 10W-40 and 15W-40 are specified
- Protects engines in salt water environments



Size	Bishops Code
5L	70520690
20L	70520695

15W-40 MARINE DIESEL 4-STROKE ENGINE OIL

- Semi-synthetic oil
- Suitable for use with coastal and marine engines that use diesel fuel only
- Anti-corrosion protection
- Mild ash formulation
- Resists oil thickening



Size	Bishops Code
20L	70520705

25W-40 MARINE 4-STROKE ENGINE OIL

- Mineral based engine oil
- Contains advanced anti-wear additives and specialised rust inhibitors
- Designed for use on inboard/outboard motors
- Protects against salt water environments



Size	Bishops Code
5L	70520720



TRANSMISSION FLUID & GEAR OILS

ATF DX-III AUTO TRANSMISSION FLUID

- Mineral based transmission fluid
- Contains advanced hydrocracked base oils and additive technology
- Provides superior wear protection
- Extends transmission life



Size	Bishops Code
1L	70520450
4L	70520455
20L	70520460

PRO GEAR 75W-85 FULL SYNTHETIC MANUAL TRANSMISSION OIL

- Smooth shift feel for the life of the oil
- Reducing harmful deposits
- Will not harm brass or bronze
- Compatible with synchro materials
- Excellent wear protection
- Contains synthetic base oils for longer life



Size	Bishops Code
1L	70520335
2.5L	70520340
20L	70520345

TRANS GEAR 75W-90 SEMI-SYNTHETIC MANUAL GEARBOX & TRANSAXLE OIL

- Smooth shift feel for the life of the oil drain
- Reduces harmful deposits
- Excellent wear protection
- Protects against gear pitting
- Can extend transmission drain intervals



Size	Bishops Code
20L	70520348

10W-40 MC GEAR OIL

- Mineral based high performance oil
- Specially formulated for separate gear boxes in 2 and 4 stroke motorcycles
- Prevents clutch slip and improves gear shifts
- Excellent wear protection



Size	Bishops Code
1L	70520750

75W-90 MARINE GEAR OIL

- Fully synthetic gear oil
- Suitable for outboard gear motors and stern drive units
- Improves start at low temperatures
- Blue



Size	Bishops Code
500ml	70520650

80W-90 PREMIUM MINERAL GEAR OIL

- Mineral based automotive gear oil
- Contains extreme pressure additives and friction modifiers
- Suitable for use in passenger cars, light commercial vehicles, 4WDs, trucks and construction equipment
- Blue



Size	Bishops Code
1L	70520350
2.5L	70520355
20L	70520365

85W-140 PREMIUM MINERAL GEAR OIL

- Mineral based automotive gear oil
- Maximum protection
- Contains extreme pressure additives and friction modifiers
- Suitable for use in passenger cars, light commercial vehicles, 4WDs, trucks and construction equipment



Size	Bishops Code
1L	70520375
2.5L	70520380
20L	70520385

EP 320 MINERAL GEAR OIL

- Premium mineral extreme pressure gear oil
- Contains highly refined water white base oils, selected sulphur-phosphorous extreme pressure and anti-wear additives
- Suitable for use in crushers, hoists, conveyors, winches, lathes and more
- Protects against rust and corrosion
- Minimises foaming



Size	Bishops Code
20L	70520395

ISO 46 HYDRAULIC OIL

- High quality low zinc oil
- Contains advanced anti-wear additives
- Protects against wear and corrosion
- Suitable for use in most types of hydraulic systems
- Reduces sludge formation
- Compatible with silver components



Size	Bishops Code
20L	70520400

INDUS HV 68 HYDRAULIC OIL

- Zinc and chlorine free hydraulic oil
- Contains selected hydro-treated base stocks, highly shear stable viscosity modifier, and advanced anti-wear additive
- Suitable for use in hydraulic systems used in marine, construction, mining and agricultural environments
- Reduces sludge formation
- Compatible with silver components
- Fluorescent light yellow colour



Size	Bishops Code
5L	70520410
20L	70520415
205L	70520420

INDUSTRIAL COMPRESSOR OIL 2KH

- Up to 2,000 hour oil drains
- High resistance to oxidation, reducing sludge deposits
- Good water demulsibility
- Excellent protection against wear
- Excellent filterability



Size	Bishops Code
20L	70520140

INDUSTRIAL COMPRESSOR OIL 4KH

- Up to 4,000 hour oil drains
- Reduces system deposits
- Good water demulsibility
- Excellent protection against wear



Description	Size	Bishops Code
Indus Compressor Oil 4KH ISO 68	5L	70520135
Indus Compressor Oil 4KH ISO 46	20L	70520120

AIR TOOL OIL

- Suitable for oiling of air tools
- A high performance anti-wear hydraulic oil formulated for use with most pumps, valves and seal material used in hydraulic systems
- Provides excellent wear and corrosion protection
- Enhanced air release and anti-foam properties prevent cavitation
- Excellent filterability prevents filter blockages
- Good demulsibility ensures hydraulic system performance is maintained with small amounts of water
- Viscosity 32 @ 40°C



Size	Bishops Code
250ml	70095360
1L	70095362

AIR TOOL LUBRICATION KIT

- Includes:**
- 1 x 100ml Lubricant grease
 - 1 x Applicator



Description	Bishops Code
Air Tool Lubrication Kit	73675002
Replacement Grease To Suit Lubrication Kit	73675004

SYNTHPLUS CHAIN OIL

- High-performance lubricant is extremely suitable for all moving saw chains
- Effectively protects saw chains from wear
- High temperature resistance, cutting attachments are optimally protected even from short-duration maximum thermal loads
- Smoking is inhibited
- Even at temperatures down to -20°C, STIHL chain lubricant retains its outstanding flow properties
- Selected additives prevent resinification of the cutting attachment and other treated parts



STIHL

Item Code	Size	Bishops Code
7004 871 0262	1L	70095120
7004 871 0397	5L	70095135
7004 871 0052	20L	70095140

HOW VISCOUS IS YOUR OIL?

One of the most important factors of an oil is its viscosity. The thickness of an oil affects how easily it flows through your parts and covers them. When expecting leaks, it is best to use high viscosity oils which won't penetrate small gaps.

Specialised oils aren't designed to operate in varying temperatures, instead they are made with different viscosities to best suit their purpose. These oils are classified using the Viscosity Index (VI).

Viscosity Index (VI) Chart

Viscosity Index	Viscosity
<35	Low
35-80	Medium
80-110	High
>110	Very High



MAINTENANCE LUBRICANTS

GENERAL PURPOSE LIQUID LANOLIN LANOTEC

- Penetrant
- Light lubricant and corrosion inhibitor for light chains, locks, hinges, zippers and padlocks
- Frees up rusted tools and stops squeaks
- Electrical component protection including air conditioner units and ECU's, non-conductive to 70kV
- Lubricant for drilling, cutting, machining and pressing
- Rejuvenates plastics, vinyl, leather, aluminium and powder coated surfaces



Item Code	Size	Bishops Code
GP\PP-0400	400g Aerosol	32003040
GP\SP-0750	750ml Spray Pack	32003050
GP\0005	5L	32003055
GP\0020	20L	32003060

HEAVY DUTY LIQUID LANOLIN LANOTEC

- Lubrication of moving parts in corrosive environments
- Wire rope lubrication and corrosion protection
- Lubrication and protection of high speed and load bearing chains (non-fling and non-webbing)
- Spray on anti-seize
- Protection of electrical equipment, non-conductive to 70kV
- Ideal for marine, mining and offshore applications



Item Code	Size	Bishops Code
HD\PP-0400	400g Aerosol	32003070
HD\SP-0750	750ml Spray Pack	32003080
HD\0005	5L	32003095
HD\0010	10L	*HD\0010
HD\0020	20L	32003090

* - SPECIAL ORDER: PLEASE QUOTE ITEM CODE UPON ORDERING THIS PRODUCT

5-56 MULTI-PURPOSE LUBRICANT CRC

- Multi-purpose lubricant with superior penetrating power that breaks through rust and corrosion while it clears away scale and dirt
- Eliminates the need for many disassembly operations
- Lubricates for smooth action, and silences annoying squeaks and squeals
- Protects metals against corrosion and displaces moisture to help start wet engines
- A moisture eliminator – for wet equipment and barrier to prevent trouble before it starts



Item Code	Size	Bishops Code
5028	175g Aerosol	32002270
5005	400g Aerosol	32002280
5004	4L	32002290
5009	20L	32002300

WD-40 MULTI-USE PRODUCT

- Stops squeaks
- Drives out moisture
- Cleans and protects
- Loosens rusted parts
- Frees sticky mechanisms
- 360° valve allowing spray at any angle



Item Code	Size	Bishops Code
61104	425g Aerosol	32004200
61114	4L Liquid	32004202

WD-40 SPECIALIST HIGH PERFORMANCE SILICONE LUBRICANT

- Non-staining, hard working formula does not attract dirt
- Prevents parts from sticking
- Waterproofs and protects against moisture
- Temperature range: -40°C to 200°C
- Suitable for use on metal, plastic, rubber and wood
- Ideal for for guide rails, pipes, hoists, hinges, belts, bearings, linkages, tools, valves, locks and doors
- Size: 300g



Item Code	Bishops Code
21101	32004210

808 SILICONE LUBRICANT SPRAY CRC

- Multi-purpose silicone spray
- Non-corrosive formula that provides a thin, durable, clear, odourless film that lubricates, protects and eliminates squeaking and binding caused by friction
- Excellent mould release
- Clear, non-staining and odourless
- Resists moisture
- Reduces friction, wear and noise
- Size: 330g aerosol



Item Code	Bishops Code
3055	32002210

FOOD GRADE CHAIN LUBE CRC

- Foaming action for outstanding penetration and coverage
- No messy overspray
- Penetrates, lubricates and protects
- Low viscosity formula creeps deep between wire strands, chain links, pins, rollers and sprockets
- Reduces friction, wear and load stress
- Non-drying film lubricates metal surfaces
- Size: 340g aerosol



Item Code	Size	Bishops Code
FG03055	340g Aerosol	32002705

TAC 2 ADHESIVE LUBRICANT

- An exceptional lubricant, with a tough adhesive quality
- Bonds to chain/wear surfaces to keep them in peak operating condition by reducing friction and wear that cause metal fatigue
- Effectively lubricates chain drives, open gears, pulleys, wire ropes and conveyors
- Resists cold, hot and salt water wash-off and high temperature sling-off
- Reduces wear and friction
- Size: 300g aerosol



Item Code	Bishops Code
5035	32002380

LONG LIFE ANTI-RUST LUBRICANT

- Provides both superior lubrication and heavy duty corrosion protection for metal parts and assemblies that are stored indoors
- High pressure properties – withstands up to 1,250lb (566kg) load in Falex test method ASTM-D-3233
- Corrosion resistance up to 2 years
- Long life gives excellent protection for all metal tools, marine equipment, fishing gear and fire arms
- Easy to remove
- Size: 300g aerosol



Item Code	Bishops Code
3097	32002250

CHAIN LUBE RACE

- Fully synthetic high performance chain lubricant
- Designed for high speed racing situations
- Wear and corrosion protection
- Low friction



Size	Bishops Code
500ml	70520765

P26 MULTI-PURPOSE LUBRICANT

- Professional strength automotive lubricant
- Stops squeaks and creaks
- Rust and corrosion protection
- Size: 400ml



Item Code	Bishops Code
P26MPL0004	70521705

WIRE ROPE LUBRICANT

- Penetrates, lubricates and protects wire ropes operating in corrosive environments or above 16mm diameter
- Ideal for use around waterways and environmentally sensitive areas
- Semi-fluid grease, can be sprayed or manually applied
- Penetrates to the core of the rope whilst remaining on the outer strands to provide long lasting protection and lubrication
- Ideal for marine cranes working in the splash zone
- Size: 20L



Item Code	Bishops Code
HW\RL20-CUBE	32003160

5-56 MARINE LUBRICANT

- Multi-purpose compound designed to end damage due to water and salt atmosphere in marine engines and boating equipment
- Displaces moisture and forms a continued non-hardening molecular film, protecting equipment
- Penetrates and loosens scale, frees frozen parts, cleans and lubricates
- Size: 300g aerosol



Item Code	Bishops Code
6006	32002590

WIRE ROPE SPRAY

- Semi-fluid grease lubricant containing molybdenum disulphide
- Designed for the lubrication and corrosion prevention requirement of wire ropes
- Applications include wire ropes, dockyard cranes, mobile cranes, chain lifts, slipways and flying foxes
- Suitable for all environments including marine and mining
- Size: 300g aerosol



Item Code	Bishops Code
RY452412	32220096

2-26 ELECTRICAL LUBRICANT

- A stable, inert organic formula, especially prepared to prevent malfunction and deterioration (due to the effect of moisture and corrosion), extends operational life, reduces down time and maintenance
- Contains no silicone
- A penetrant – frees rusted or corroded parts
- Size: 450g aerosol



Item Code	Bishops Code
2005	32002010



GRAPHITE POWDER & PENETRANTS

GRAPHITE POWDER

- Ultra-fine dry lubricant
- Suitable for use on oil-based products that attract dust
- Size: 35g puff pack



Item Code	Bishops Code
PP120	32418005

DEFINING PENETRANTS

Penetrants are specialised lubricants used to release parts and fittings to enable disassembly and to clean or clear parts and assemblies from the effects of their wearing environment, typically rust or corrosion. You'll typically find three different types:

Rust Converters chemically convert the rusted oxide surface to a stable iron phosphate compound which can be safely cut, welded and painted.

Rust & Corrosion penetrants dissolve and strip back rusted parts and surfaces back to bare metal, allowing them to be finished. They can also be used to dissolve rusted fasteners, allowing them to be loosened.

Gasket penetrants dissolve gasket material that may be stuck in place. This allows for the surface to be cleaned and fitted with a new gasket.

LANO-FORM & RELEASE AGENT

LANOTEC

- A lanolin based, water soluble concrete release agent
- For formwork, precast and tilt panel
- Ideal for environmentally sensitive areas
- Lubrication of jacks and fittings
- Protection of equipment from concrete and paint overspray
- Lano-Form is a ready-to-use release agent



Item Code	Description	Size	Bishops Code
RA\0003	Concentrate	2.9L	32003120
RA\0005	Concentrate	5L	32003125
RA\LF-0010	Ready-To-Use	10L	*RA\LF-0010
RA\0020	Concentrate	20L	32003130
RA\LF-0020	Ready-To-Use	20L	*RA\LF-0020

* - SPECIAL ORDER: PLEASE QUOTE ITEM CODE UPON ORDERING THIS PRODUCT

3-36 HEAVY DUTY PENETRANT



- A multiple organic inhibitor in a paraffinic oil base that prevents rust and corrosion by displacing and sealing out moisture and by forming a continuous protection barrier against water and oxygen
- Thin invisible film that never dries or becomes brittle
- Extremely low surface tension
- Penetrates into pores and cracks
- Low surface tension and an affinity for metal ensures that a continuous film of product will blanket every part of the surface
- Size: 300g aerosol



Item Code	Bishops Code
3005	32002170

FOOD GRADE PENETRATING OIL



- General purpose non-silicone penetrant
- Eases disassembly of mechanical equipment
- Low surface tension formula creeps into cracks, seams, threads and joints with great efficiency
- Improves performance and operating efficiency
- Loosens rusted and corroded nuts, bolts, couplings, fittings and hinges
- Colourless, tasteless and odourless
- Temp. range: -20°C to 150°C
- Size: 312g aerosol



Item Code	Bishops Code
FG03086	32002720

GALMET® IRONIZE RUST CONVERTER & SEALER



- Fast reacting rust converter and sealer
- Enamel paint can be applied over the surface after 3 hours
- Up to 3 months corrosion protection without re-coating
- Provides a tough and flexible film
- Size: 1L



Item Code	Bishops Code
GICS1L	66520125

RANEX RUSTBUSTER

- Penetrates to chemically destroy rust
- Removes surface rust
- Cleans and polishes chrome, brass, copper, and more
- Dissolves and cleans off rust bore water stains



Size	Bishops Code
4L	32004204
20L	32004206

PROTECT YOUR PARTS

Protectants are designed to be applied to operating assemblies either for storage, extended life purposes or at the conclusion of the maintenance process prior to the assembly going back into operation. They protect parts from environmental effects such as rust and corrosion, as well as working conditions including water exposure, abrasion and earth submersion.

SOFT SEAL HEAVY FILM PROTECTANT

- A long term indoor/outdoor corrosion inhibitor for machined surfaces and assemblies subjected to long periods of storage or adverse shipping conditions
- Displaces moisture and provides a transparent, amber waxy film for heavy protection of parts, equipment and machinery
- Provides heavy corrosion protection to preserve and lengthen useful life of equipment subject to heat, humidity, chemicals or corrosive atmospheres
- Never becomes brittle and will not craze
- Size: 300g aerosol



Item Code	Bishops Code
3013	32002180

STEEL-SEAL® CORROSION INHIBITOR

- A low-tack protective film for all metal surfaces
- Parts storage protection
- 4WD and LV underbodies
- Trucks, trailers, agriculture and marine
- Heavy industrial machinery and plant
- Not recommended for galvanised surfaces



Item Code	Size	Bishops Code
SS\PP-0400	400g Aerosol	*SS\PP-0400
SS\SP-0750	750ml	32003098
SS\0003	3L	*SS\0003
SS\0005	5L	32003100
SS\0010	10L	*SS\0010
SS\0020	20L	32003110

* - SPECIAL ORDER: PLEASE QUOTE ITEM CODE UPON ORDERING THIS PRODUCT

PROTECTANTS & PIPE PRIMERS & TAPE

DENSO MP PRIMER

- For mechanical protection of Denso™ Petrolatum Tape System in high service temperature environments
- A component of the Denso™ Petrolatum System, protecting pipelines, joints and fittings above and below ground
- Suitable for creating a moisture barrier in refrigeration units
- Designed to withstand up to 55°C



P300002.5-44

Item Code	Size
P300002.5-44	2.5kg Tub
P300015-44	15kg Drum

SPECIAL ORDER: PLEASE QUOTE ITEM CODE UPON ORDERING THIS PRODUCT

DENSYL™ TAPE

- Corrosion protection, sealing and waterproofing of metal above or below the ground
- Designed to withstand temperatures up to 70°C
- Provides long term corrosion protection to pipes, flanges, valves and related surface
- Length: 10m



P6100100-44

Item Code	Width
P6100050-44	50mm
P6100075-44	75mm
P6100100-44	100mm
P6100150-44	150mm

SPECIAL ORDER: PLEASE QUOTE ITEM CODE UPON ORDERING THIS PRODUCT

DENSYL KF COLOURTAPE™

- Designed to withstand extreme temperature variations and is resistant to surface spread of flame
- Provides long term corrosion protection to pipes, flanges, valves and related surfaces
- Specially stabilised and pigmented for use above ground where appearance is important
- Waterproofing of cables and thermal insulation where fire resistance is important
- Length: 8m



P620100

Item Code	Width
P620050	50mm
P620100	100mm

SPECIAL ORDER: PLEASE QUOTE ITEM CODE UPON ORDERING THIS PRODUCT

GET MORE AT BISHOPS



SURFACE PREPARATION PRODUCTS

From Page 122



PIPE REPAIR PRODUCTS

DENSO™ PVC SA OVERWRAP TAPE

- For mechanical protection of Denso™ Petrolatum Tape System in high service temperature environments
- A component of the Denso™ Petrolatum System, protecting pipelines, joints and fittings above and below ground
- Suitable for creating a moisture barrier in refrigeration units
- Designed to withstand temperatures up to 75°C
- Length: 30m



P931025

P932100

P932150

BLACK			YELLOW		
Item Code	Size	Bishops Code	Item Code	Size	Bishops Code
P931025	25mm	*P931025	P932025	25mm	*P932025
P931050	50mm	66542145	P932050	50mm	*P932050
P931100	100mm	66542148	P932100	100mm	*P932100
P931150	150mm	66542150	P932150	150mm	*P932150

* - SPECIAL ORDER: PLEASE QUOTE ITEM CODE UPON ORDERING THIS PRODUCT

DENSO TAPE™

- For protection below ground or underwater against corrosion on pipework, metal surfaces and cables and temporary sealing of fractured mains and cable joints
- Highly versatile corrosion prevention tape
- Non-hardening, non-cracking and conformable over a wide temperature range
- Designed to withstand temperatures up to 55°C as well as resistant to water, gases, mineral acids, alkalis and salts
- An ideal solution for a wide range of corrosion problems
- When correctly applied in conjunction with Denso™ MP Primer, Denso™ Mastics (when applicable) and Denso™ PVC SA Tape, assets can be protected easily and effectively
- Length: 10m



P600050-44

Item Code	Width	Bishops Code
P600050-44	50mm	66542105
P600075-44	75mm	*P600075-44
P600100-44	100mm	66542100
P600150-44	150mm	66542110
P600200-44	200mm	*P600200-44
P600300-44	300mm	*P600300-44

* - SPECIAL ORDER: PLEASE QUOTE ITEM CODE UPON ORDERING THIS PRODUCT

DENSO™ REPAIR WRAP

- Protective fibreglass outerwrap and pipe repair bandage
- Repair leaking water, sewage, air and fuel pipes



M230100

Item Code	Size
M220075	75(w)mm x 3.0(l)m
M220100	100(w)mm x 3.0(l)m
M230100	100(w)mm x 4.5(l)m

SPECIAL ORDER: PLEASE QUOTE ITEM CODE UPON ORDERING THIS PRODUCT

RAPP-IT PIPE REPAIR BANDAGE



Rapp-it Pipe Repair System is ideal in emergency situations; it is simple to apply and can save you \$1,000s in costly downtime. Rapp-it includes a woven fibreglass bandage impregnated with water-activated resin and a 90mm stick of Rapp-it Steel Putty.

- Successfully repair a leaking or damaged pipe in just 30 minutes
- Easy to apply – no mixing or measuring required
- Resistant to most chemicals, diluted acids and fuels
- Withstands pressure up to 360psi (2,500kPa) and temperatures of 150°C
- Potable water certified AS/NZS 4020:2018
- Suitable for construction, engineering, mining, oil and gas, petrochemical, processing, manufacturing, marine and agricultural industries
- Ideal for acid lines, sea water, CHPP and many different pipe shapes and substrates, including polypipe (PP/HDPE), GRE, steel, PVC, rubber, concrete, galvanised, ceramic, clay, stainless steel, basalt, fibreglass, copper and all insert piping



Item Code	Size	Bishops Code
RAP122	50(w) x 3,600(l)mm	32428120
RAP123	75(w) x 3,600(l)mm	32428130
RAP124	100(w) x 3,600(l)mm	32428140
RAP164	100(w) x 4,800(l)mm	32428160
RAP304	100(w) x 9,000(l)mm	32428170

GET MORE AT BISHOPS

SPILL KITS

Page 41















FACE SHIELDS











Page 18



WORK HEALTH & SAFETY REGULATIONS

Classification and labelling for workplace hazardous chemicals

CLASSIFICATION		LABELLING			
Hazard		Pictogram, Code*	Signal Word	Hazard Statement	
Class	Category			Code*	Text
Explosives	Unstable explosive		Danger	H200	Unstable explosive
	Division 1.1			H201	Explosive; mass explosion hazard
	Division 1.2			H202	Explosive; severe projection hazard
	Division 1.3			H203	Explosive; fire, blast or projection hazard
	Division 1.4	GHS01	Warning	H204	Fire or projection hazard
	Division 1.5	No GHS Pictogram ⁽¹⁾	Danger	H205	May mass explode in fire
	Division 1.6	No GHS Pictogram ⁽¹⁾	No Signal Word	N/A	No Hazard Statement
(1)=Explosives of Divisions 1.5 and 1.6 need to be labelled with their respective Dangerous Goods class label in accordance with the Australian Explosives Code.					
Flammable Gases	Category 1		Danger	H220	Extremely flammable gas
Flammable Aerosols	Category 1		Danger	H222	Extremely flammable aerosol
	Category 2		Warning	H223	Flammable aerosol
Oxidising Gases	Category 1		Danger	H270	May cause or intensify fire; oxidiser
Gases under Pressure ⁽²⁾	Compressed gas		Warning	H280	Contains gas under pressure; may explode if heated
	Liquefied gas			H281	Contains refrigerated gas; may cause cryogenic burns or injury
	Dissolved gas				
	Refrigerated liquefied gas				
(2) = The hazard class "Gases under Pressure" is subdivided into "Groups" (not "Categories").					
Flammable Liquids	Category 1		Danger	H224	Extremely flammable liquid and vapour
	Category 2		H225	Highly flammable liquid and vapour	
	Category 3		Warning	H226	Flammable liquid and vapour
	Category 4		No Pictogram	Warning	H227
Flammable Solids	Category 1		Danger	H228	Flammable solid
	Category 2		Warning		
Self-reactive substances and mixtures ⁽³⁾ Organic Peroxides ⁽³⁾	Type A		Danger	H240	Heating may cause an explosion
	Type B			H241	Heating may cause a fire or explosion
	Type C and D	GHS01 + GHS02	Warning	H242	Heating may cause a fire
	Type E and F	GHS02			
	Type G	No Pictogram			
(3) = Two separate hazard classes have the same categories (and are therefore grouped).					
Pyrophoric Liquids	Category 1		Danger	H250	Catches fire spontaneously if exposed to air
Pyrophoric Solids	Category 1		Danger	H251	Self-heating; may catch fire
Self-heating substances and mixtures	Category 1		Danger	H252	Self-heating in large quantities; may catch fire
	Category 2		Warning	H260	In contact with water releases flammable gases which may ignite spontaneously
Substances and mixtures which, in contact with water, emit flammable gases	Category 1		Danger	H261	In contact with water releases flammable gases
	Category 2		Danger	H262	In contact with water releases flammable gases
	Category 3		Warning	H271	May cause fire or explosion; strong oxidiser
Oxidising Liquids ⁽⁴⁾	Category 1		Danger	H272	May intensify fire; oxidiser
Oxidising Solids ⁽⁴⁾	Category 2		Danger	H273	May cause environmental damage
	Category 3		Warning	H274	May cause environmental damage
(4) = Two separate hazard classes have the same categories (and are therefore grouped).					
Corrosive to metals	Category 1		Warning	H290	May be corrosive to metals
Acute Toxicity (Oral, Dermal or Inhalation)	Category 1		Danger	H300	Fatal if swallowed
	Category 2			H310	Fatal in contact with skin
	Category 3			H330	Fatal if inhaled
				H301	Toxic if swallowed
	Category 4			H311	Toxic in contact with skin
Category 4	H331	Toxic if inhaled			
	H302	Harmful if swallowed			
	H312	Harmful in contact with skin			
Category 4	H332	Harmful if inhaled			

CLASSIFICATION		LABELLING				
Hazard		Pictogram, Code*	Signal Word	Hazard Statement		
Class	Category			Code*	Text	
Skin corrosion/irritation	Category 1A		Danger	H314	Causes severe skin burns and eye damage	
	Category 1B					
	Category 1C					
Category 2		Warning	H315	Causes skin irritation		
					Category 2	
Serious eye damage/eye irritation	Category 1		Danger	H318	Causes serious eye damage	
	Category 2A		Warning	H319	Causes serious eye irritation	
Sensitisation of the respiratory tract or the skin	Respiratory Sensitisers Category 1		Danger	H334	May cause allergy or asthma symptoms or breathing difficulties if inhaled	
	Skin Sensitisers Category 1		Warning	H317	May cause an allergic skin reaction	
Germ cell mutagenicity	Category 1A		Danger	H340	May cause genetic defects ⁽⁵⁾	
	Category 1B		Warning	H341	Suspected of causing genetic defects ⁽⁵⁾	
Carcinogenicity	Category 2		Danger	H350	May cause cancer ⁽⁵⁾	
	Category 1A		Warning	H351	Suspected of causing cancer ⁽⁵⁾	
	Category 1B		Warning	H351	Suspected of causing cancer ⁽⁵⁾	
(5) = State route of exposure if it is conclusively proven that no other routes of exposure cause the hazard.						
Reproductive toxicity	Category 1A		Danger	H360 ⁽⁶⁾	May damage fertility or the unborn child	
	Category 1B			H360F ⁽⁷⁾	May damage fertility	
				H360D ⁽⁷⁾	May damage the unborn child	
				H360FD ⁽⁷⁾	May damage fertility. May damage the unborn child	
				H360Fd ⁽⁷⁾	May damage fertility. Suspected of damaging the unborn child	
Category 2	H360Df ⁽⁷⁾	May damage the unborn child				
	H360Dfd ⁽⁷⁾	May damage the unborn child. Suspected of damaging fertility				
	H361 ⁽⁶⁾	Suspected of damaging fertility or the unborn child				
	H361F ⁽⁷⁾	Suspected of damaging fertility				
Additional category for effects on or via lactation	No Pictogram	No Signal Word	H362	May cause harm to breast-fed children		
					H361D ⁽⁷⁾	Suspected of damaging the unborn child
					H361Dfd ⁽⁷⁾	Suspected of damaging fertility. Suspected of damaging the unborn child
(6) = (state specific effect if known)(state route of exposure if it is conclusively proven that no other routes of exposure cause the hazard). (7) F = Fertility, D = Development (lowercase f, d = suspected effect).						
Specific target organ toxicity (single exposure)	Category 1		Danger	H370	Causes damage to organs ⁽⁸⁾	
	Category 2		Warning	H371	May cause damage to organs ⁽⁸⁾	
	Category 3		Warning	H335	May cause respiratory irritation	
Specific target organ toxicity (repeated exposure)	Category 1		Danger	H372	Causes damage to organs ⁽⁸⁾ through prolonged or repeated exposure ⁽⁹⁾	
	Category 2		Warning	H373	May cause damage to organs ⁽⁸⁾ through prolonged or repeated exposure ⁽⁹⁾	
	Category 3		Warning	H374	May cause damage to organs ⁽⁸⁾ through prolonged or repeated exposure ⁽⁹⁾	
(8) = (state all organs affected, if known). (9) = (state route of exposure if it is conclusively proven that no other routes of exposure cause the hazard).						
Aspiration Toxicity	Category 1		Danger	H304	May be fatal if swallowed and enters airways	

* = The code for the Pictogram and Hazard Statement should not be included on the label. Further information on classification, labelling and safety data sheet requirements under the WHS Regulations, including transitional arrangements, is available from the Safe Work Australia website at www.safeworkaustralia.gov.au.



CUTTING & GRINDING FLUID & INDUSTRIAL DEGREASERS

RTD METAL CUTTING FLUID

- Metal cutting liquid, paste, spray for reaming, tapping and drilling on all metals

RTD Liquid:

- A medium viscosity metal cutting liquid that reduces friction and can be easily applied to difficult surfaces

RTD Compound:

- A soft, low melting point metal cutting lubricant in paste form that can be applied directly by brush



RY550181



RTD LIQUID		RTD COMPOUND			
Item Code	Size	Bishops Code	Item Code	Size	Bishops Code
RY53062	350g	32220081	RY551211	500g	32220010
RY550171	500ml Squeeze Pack	32220094	RY551221	2.5kg	32220020
-	-	-	RY550181	5L	32220095

ULTRACUT PREMIUM

- High performance metal cutting fluid
- Bio-stable, extreme pressure (EP) water soluble oil formulated to provide premium cutting performance and excellent corrosion resistance
- Excellent residual corrosion protection
- Low foaming characteristics



RY562621



Item Code	Size	Bishops Code
RY562611	5L	32220090
RY562621	20L	32220092

LAPPING COMPOUND

- Water-mixed aluminium oxide abrasive
- Holds the grit in suspension and provides lubrication
- Size: 500g



Grit	Bishops Code	Grit	Bishops Code
120	32218005	500	32218020
240	32218010	700	32218030
320	32218015	-	-

VALVE GRINDING COMPOUND

- Water-mixed silicon carbide abrasive
- Can be used in many grinding applications including hardened engine poppet valves



Grit	Size	Bishops Code	Grit	Size	Bishops Code
Fine	75g	32214020	Medium	500g	32214070
Fine	150g	32214030	Coarse	75g	32214080
Fine	500g	32214040	Coarse	150g	32214090
Medium	75g	32214050	Coarse	500g	32214100
Medium	150g	32214060	Fine & Coarse	50g	32214120

DIFFERENCE BETWEEN DEGREASERS & SURFACE CLEANERS

The distinction between degreaser and surface cleaner can often be unclear. To clear things up, the definition for each product and what they are best used for is explained below.

Degreasers

Degreasers are simply defined as a chemical product that removes grease. On the acidity scale, degreasers are more alkaline (pH 8-12). This allows them to break down tough, organic soils such as grease. Some degreasers also include solvents to help further 'cut through' grease and oils.

Surface Cleaners

Surface cleaners are ideal for general purpose cleaning applications, on surfaces that are lightly soiled or dusted. All-purposes are typically a pH neutral (pH 6-8), this makes them safer for people and surfaces.

pH Chart

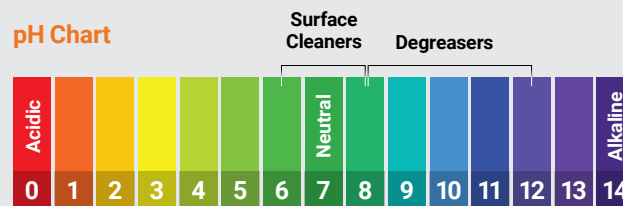

SUPREME CLEANER & DEGREASER



- Concentrated product formulated for heavy-duty degreasing tasks such as engines, machinery, manufacturing equipment, dip tanks, HVACR coils and cooling towers
- Use in aqueous-based parts washer, steam cleaners, floor scrubbers, pressure sprayers and ultrasonic baths
- Ideal for a wide range of industries including manufacturing, mining, automotive and engineering
- Features Quick Break for use in facilities equipped with an oil/water separator
- Not classified as hazardous according to Model Work Health & Safety Regulations and GHS criteria



Item Code	Size
SG13492	20L Drum
SG13493	200L Drum
SG13494	1,000L IBC

SPECIAL ORDER: PLEASE QUOTE ITEM CODE UPON ORDERING THIS PRODUCT

CITRA-FORCE® CLEANER & DEGREASER

LANOTEC

- A powerful, all purpose, natural cleaner/degreaser concentrate
- Safely cleans stainless steel, aluminium and anodised surfaces without streaking (neutral pH)
- Removes oil, grease, carbon, adhesives, acrylic paint overspray, shipping waxes, blackjacks, uncured silicone or sealants, rubberised glues, Lanotec lanolin-based products
- Cleans electrical components, foam filters, workshop floors, toilets and showers, BBQs, pet stables and exhaust canopies
- Citra-Force® affects certain polymers, do not use on rubber or plastics before testing on an inconspicuous area



Item Code	Size	Bishops Code
CF\PP-0400	400g Aerosol	32003010
CF\SP-0750	750ml Spray Pack	32003012
CF\0005	5L	32003020
CF\0010	10L	*CF\0010
CF\0020	20L	32003030
CF\0200	200L	*CF\0200

* - SPECIAL ORDER: PLEASE QUOTE ITEM CODE UPON ORDERING THIS PRODUCT

SUPERCLENE DEGREASER

SEPTONE®

- Multi-purpose cleaner/degreaser
- Citrus-based
- Penetrates and emulsifies grease, oil and dirt
- Environmentally friendly, caustic-free and phosphate-free
- Non-flammable
- Ideal as workshop floor cleaner, general degreaser, heavy duty vehicle and machinery wash



HSS20

Item Code	Size	Bishops Code
HSS5	5L	32814054
HSS20	20L	32814056

DEGREASE IT

SEPTONE®

- Heavy duty water-based degreaser
- Quick break, biodegradable
- Solvent-free and phosphate-free
- Penetrates and emulsifies grease, oil and dirt



ADDI20

Item Code	Size	Bishops Code
ADDI5	5L	32814062
ADDI20	20L	32814064

DEGREASING FLUID

- A powerful, water-soluble solvent blend specially designed to penetrate and dissolve built-up grime and grease
- Clear, pale-orange liquid with a strong odour
- Cleaning oil and grease stains from concrete driveways, garage floors, motorcycle and car engines
- Water-miscible, solvent-based



Item Code	Size	Bishops Code
17077-61DIG	1L	66550246
17077-4DIG	4L	66550248

OILSOLVE DEGREASER

SEPTONE®

- Heavy duty solvent degreasing fluid
- Quick break
- Safe on all metals and parts
- Suitable for motor parts, machinery and concrete driveways
- Size: 20L



Item Code	Bishops Code
ADO20	32814072

LIGHTNING SOLVENT DEGREASER

- Professional strength solvent-based degreaser
- Rapidly dissolves oil, grease, brake dust, silicone and more
- Cleans parts without the need for dismantling
- Fast acting and non-corrosive
- Size: 20L



Size	Bishops Code
MASD020	70521850

GET MORE AT BISHOPS



BUCKETS

Page 408



INDUSTRIAL, PRECISION & ELECTRICAL CLEANERS & DEGREASERS

HULL CLEANER STAIN REMOVER

- Acid-based cleaner incorporating a biodegradable surfactant
- Cleans and revives fibreglass gelcoat, painted timber surfaces and steelwork
- Ideal for de-yellowing gelcoats/fibreglass
- Phosphoric acid formula is most effective at removing rust stains, converting rust and inhibiting its reformation



MCD1

SEPTONE

Item Code	Size	Bishops Code
MCD1	1L	32812230
MCD5	5L	32812235

HOT SHOT ENGINE DEGREASER

- CRC Hot Shot Degreaser is used on most metal surfaces including car and truck motors, chain saws, boats, lawn mowers, garage floors and industrial and farm machinery
- Rinses off easily and leaves no residue
- Quickly dissolves grease, oil and dirt
- Cleans iron, steel, aluminium, magnesium and copper
- Not harmful to metal, rubber, plastic or concrete
- Size: 500g aerosol



Item Code	Bishops Code
5073	32002490

BRAKLEEN BRAKE & PARTS CLEANER

- Fast evaporation
- Minimises downtime associated with 'clean-in-place' cleaning methods
- Residue-free
- Prevents harmful build-up and eliminates rinsing or wiping
- Non-staining and non-corrosive



Item Code	Size	Bishops Code
5089	500g Aerosol	32002520
5091	20L	32002525

P26 MULTI-PURPOSE CLEANERS & DEGREASER

- Professional strength automotive cleaning products

P26 Multi-Purpose Degreaser:

- Solvent-based
- Cleans parts without need for dismantling

P26 Throttle Body & Carb Cleaner:

- Cleans fuel and air intake/delivery systems
- Breaks down slime, sediment and sludge



70521710

70521715

Description	Size	Bishops Code
P26 Multi-Purpose Degreaser	400g	70521710
P26 Throttle Body & Carb Cleaner	400g	70521715

CO CONTACT CLEANER

- A unique, plastic safe, scientifically formulated, technically proven, stable, inert high purity cleaning solvent
- Non-corrosive, non-staining, rapid-complete evaporation and contains no lubricants
- Contains COZOL – a special proprietary blend of solvents which enhances the cleaning power without damaging plastics
- Fast evaporation
- Minimises downtime associated with "clean-in-place" cleaning methods
- Size: 350g aerosol



Item Code	Bishops Code
2016	32002040

LECTRA-CLEAN ELECTRIC MOTOR CLEANER

- Contains no trichloroethylene and is a unique, scientifically formulated cleaner/degreaser that is effective in most heavy-duty applications
- Dissolves grease, oil and sludge quickly for more efficient operation of mechanical equipment
- Significantly reduces the risk of fire caused by incidental contact with live electrical equipment or solvents trapped by insulating materials
- Non-flammable
- No flash point, no fire point



Item Code	Size	Bishops Code
2018	400g Aerosol	32002060
2020	4L	32002070

GET MORE AT BISHOPS



METAL POLISH

Page 402

ALI BRITE

- Aluminium and stainless steel cleaner
- Acid etch cleaner
- Concentrate formula
- Removes corrosion and oxide film
- Suitable on bullbars, trailers and dinghies

ATA5



SEPTONE

ALL PURPOSE THINNER

- A general purpose paint thinner and cleaning solvent
- Suitable for thinning solvent based paint, acrylics and epoxies
- Improves paint consistency and reduces the risk of imperfections
- Fast drying with a smooth gloss finish
- Recommended to wear suitable protective clothing and accessories while using this product



Item Code	Size	Bishops Code
ATA1	1L	32812240
ATA5	5L	32812245

Item Code	Size	Bishops Code
1700-4DIG	4L	66550222
1700-20	20L	66550224

WAX & GREASE REMOVER

- Highly effective surface preparation treatment which removes wax, grease, polish, oil, tar, grime, glue and most other contaminants prior to sanding and finishing
- Pre-painting surface cleaner
- Can be used on existing paint surfaces
- Heavy duty cleaning solvent
- Aids in the removal of silicone
- Suitable for use on windows, carpet, furniture and timber surfaces
- Professional finish in automotive environments
- Non-residual
- Size: 1L



METHYLATED SPIRITS

- Denatured alcohol, used domestically and commercially as a cleaner and solvent for paints, lacquers and varnishes
- Suitable for table burners and methylated spirits stoves
- Cleaner for glass, mirrors, showers, tiles, fridges, ovens and other household appliances
- Thinning agent for paints, lacquers and varnishes
- Removes ink from non-porous surfaces
- Cleaning paint brushes
- Hard-surface cleaner and disinfectant



Item Code	Bishops Code
17060-61DIG	66550244

Item Code	Size	Bishops Code
15000-1DIG	1L	66550216
15000-4DIG	4L	66550218
15000-20DIGN	20L	66550220

CALCIUM, LIME & RUST REMOVER

- A powerful industrial strength cleaner designed for domestic and commercial use
- Extremely effective in removing stains with no scrubbing required
- Removing calcium deposits, lime scale and rust stains from porcelain, sinks, baths, toilets, stainless steel, glass, chrome, fibreglass and cement
- Child-resistant packaging
- Size: 1L



MINERAL TURPENTINE

- Hydrocarbon solvent specifically designed for use in many paint formulations and associated thinners
- Combines good solvency with controlled evaporation
- Use for thinning paints, linseed oil, waxes and polishes, metal cleaning and clean-up of brushes and equipment after painting



Item Code	Bishops Code
16413-61DIG	66550240

Item Code	Size	Bishops Code
16010-1DIG	1L	66550210
16010-4DIG	4L	66550212
16010-20DIG	20L	66550214

PAINT STRIPPER

- A powerful methylene chloride based paint stripper that rapidly penetrates and lifts paint for easy removal
- Suitable for applications in automotive, industrial, marine and household areas
- Can be used on timber, metal and masonry surfaces
- The gel formula makes it suitable for vertical surfaces
- Has a coverage of approximately 0.75m² per litre
- Recommended to wear suitable protective clothing and accessories while using this product



ACETONE

- DIY cleaner and degreaser
- Use as a lacquer thinner or paint softener
- Ideal for cleaning fibreglass and PVC pipes
- 4L



Item Code	Size	Bishops Code
16885-60DIG	500ml	66550226
16885-61DIG	1L	66550228
16885-4DIG	4L	66550230

Item Code	Bishops Code
16255-4DIG	66520090



AUTOMOTIVE FUEL TREATMENTS

LUBRICANTS, SEALANTS & CHEMICALS

DIESEL BIOCIDIC FUEL TREATMENT

- Diesel fuel additive to stop bacterial growth that can cause contamination
- Prevents fuel system blockages
- Suitable for decontaminating on-site storage and tank facilities
- High flash point for safe handling



Size	Bishops Code
1L	70521900
20L	70521902

DIESEL FUEL STABILISER

- Fuel additive to stabilise diesel performance
- Prevents fuel from going stale when not used for up to 12 months
- Rust and corrosion protection



Size	Bishops Code
375ml	70521690

DIESEL INJECTOR CLEANER

- Multi-purpose fuel treatment
- Cleans injectors and reduces blockages
- Improves acceleration and power



Size	Bishops Code
375ml	70521685

DIESEL TOTAL SYSTEM CLEANER

- Professional strength diesel fuel additive
- Cleans fuel tank, lines, injectors, carburetors and inlet valves
- Reduces fuel consumption



Size	Bishops Code
375ml	70521695

GET MORE AT BISHOPS



ENGINE STAND

Page 388

ENVIRO+ DPF CLEANER

- Diesel fuel additive that cleans block diesel particulate filters
- Improves fuel economy and reduces emissions
- Cleans fuel injectors
- Improves combustion efficiency



Size	Bishops Code
375ml	70521680

PETROL FUEL STABILISER

- Fuel additive to stabilise petrol/gasoline performance
- Prevents fuel from going stale when not used for up to 12 months
- Rust and corrosion protection



Size	Bishops Code
250ml	70521672

PETROL INJECTOR CLEANER

- Multi-purpose fuel treatment
- Cleans fuel injectors and carburetors
- Increases engine power
- Rust and corrosion protection
- Suitable for all unleaded and E10 fuel



Size	Bishops Code
375ml	70521670

PETROL OCTANE BOOSTER

- Fuel treatment to enhance the octane rating of regular 91 unleaded octane petrol
- Improves power, acceleration and fuel economy
- Keeps inlet valves and injectors clean
- Suitable for older and newer type engines
- Reduces exhaust emissions



Size	Bishops Code
375ml	70521678

PETROL TOTAL SYSTEM CLEANER

- Professional strength petrol fuel additive
- Cleans fuel tank, lines, injectors, carburettors and inlet valves
- Reduces fuel consumption



Size	Bishops Code
375ml	70521675

GREEN OEM COOLANT CONCENTRATE

- OEM approved anti-boil/anti-freeze coolant
- Rust and corrosion protection
- Requires further dilution with demineralised water
- Phosphate, nitrite and amine free



Size	Bishops Code
1L	70521802

350,000KM GREEN COOLANT CONCENTRATE

- Anti-freeze/anti-boil coolant
- Requires further dilution with demineralised water
- 350,000km drain intervals
- Silicate, phosphate and amine free



Size	Bishops Code	Size	Bishops Code
1L	70521800	5L	70521810
2.5L	70521805	20L	70521815

RED OEM COOLANT PREMIX

- Ready to use anti-freeze/anti-boil coolant mix
- Borate, phosphate, nitrite and amine free
- OEM approved



Size	Bishops Code
1L	70521910
5L	70521915

ENGINE FLUSH

- Fast acting engine flush fluid
- Removes deposits, sludge and contaminants
- Added zinc for wear protection
- Solvent-free



Size	Bishops Code
375ml	70521650

RADIATOR FLUSH

- Fast acting alkaline cooling system cleaner
- Removes rust, scale and other deposits
- Improves circulation
- Compatible with all types of coolants
- Non-acidic



Size	Bishops Code
375ml	70521665

RADIATOR GREEN CORROSION INHIBITOR CONCENTRATE

- Hybrid organic corrosion inhibitor
- Protects against scaling and oxidation
- Silicate, phosphate and amine free



Size	Bishops Code
500ml	70521825



BRAKE FLUIDS, STOP LEAK & INSPECTION PRODUCTS

SUPER DOT 4 BRAKE FLUID

- Excellent braking response due to high boiling point of fluid
- High wet boiling point ensures long term retention of fluid performance
- Better performance for Life of fluid compared to DOT 3 fluids
- Compatible with all common brake system materials
- Compatible with DOT 3 and DOT 5.1 (low temperature, non-silicone type)



Size	Bishops Code
500ml	70520100
4L	70520105
20L	70520110

RACING BRAKE FLUID

- Excellent braking response due to high boiling point of fluid 316° C (600°F)
- High wet boiling point ensures long term retention of fluid performance
- Better performance for life of fluid compared to Super DOT 4 fluids
- Compatible with all common brake system materials
- Compatible with DOT 5.1 (low temperature, non-silicone type)



Size	Bishops Code
500ml	70520102

STOP LEAK AUTOMOTIVE FLUIDS

- Controls leaks in various automotive areas
- Size: 375ml



Item Code	Bishops Code
Engine Stop Leak	70521655
Radiator Stop Leak	70521660

BAR'S LEAKS STOP LEAK

- Forms a lasting repair for both internal and external leaks in the head block and/or radiator
- Principal ingredient is a natural product
- Harmless to rubber, plastic and all metals
- Non-toxic



Item Code	Size	Bishops Code
BL150	150g	32004070
BL340	340g	32004080

PRUSSIAN BLUE FITTING COMPOUND

- Aids precision-fitting of machined surfaces
- Non-drying compound
- Locates high spots on bearings, valves, gears, and other close-to-tolerance components
- Easy clean-up
- Size: 22ml tube



Item Code	Bishops Code
PX80038	32418160

WATER FINDING PASTE

- For testing the presence of water at the bottom of fuel storage tanks
- Applied to a rod or length of string with bottom weight, the brown paste changes colour to brilliant red where it comes into contact with water giving you a visual indication as to the depth of the water present
- Size: 85g tube



Item Code	Bishops Code
460-KK01	32220154

FUEL, OIL & CHEMICAL FINDING PASTE

- Can be used with a measuring gauge, rod or calibrated line to determine water or fuel level
- Light pink paste turns to a contrast of red upon contact with petrol or gasoline, naphthalene, kerosene, gas oil, crude oil, jet fuels and various chemicals
- 62g tub



Item Code	Bishops Code
KKGGP	32220156

GET MORE AT BISHOPS 



STORAGE CABINETS

Page 320

FLAWFINDER CRACK DETECTION KIT

- Three part method of crack detection for welded joints and engineering components during maintenance and manufacturing
- Ideal for cast and welded metal components, glass and ceramic components
- Use under normal light conditions
- Approved to DTD929 and meets ASME specifications



RY642543

Item Code	Description	Size	Bishops Code
RY642564	VW Penetrant	250g	32224060
RY642552	Cleaner	300g	32224070
RY642572	Developer	300g	32224080
RY642543	3 Step Flawfinder Kit		32224050

ARDROX® 8901W WHITE BACKGROUND LACQUER

- White background lacquer for visible magnetic particle inspection
- Ardrex 8901W is a suspension of a white pigment in a resin base, which utilises a fast drying, flammable solvent system
- Does not contain any halogenated hydrocarbons
- Non-chlorinated
- Size: 300g aerosol



Item Code	Bishops Code
8901W	32225010

ARDROX® 800/3 BLACK MAGNETIC INK

- Ardrex 800/3 consists of very finely divided black magnetic particles suspended in high flash point odourless kerosene designed to provide good particle mobility
- The black particles have been selected for their high magnetic response, low coercivity (to avoid coagulation) and prolonged operational life
- Pre-mixed, high sensitivity
- Size: 300g aerosol



Item Code	Bishops Code
800/3	32225011



ARDROX® 907PB RED DYE PENETRANT

- Water-washable red penetrant
- Can be used in non-destructive testing of forged parts, welds, casts and drop forged parts
- Used for the detection of defects such as cracks, laps, cold shuts, porosity, bursts, casting and welding discontinuities
- Size: 300g aerosol



Item Code	Bishops Code
807PB	32225012

ARDROX® 8501 FLUORESCENT MAGNETIC INK

- Ready-to-use suspension of a fluorescent iron oxide with the finest particle size in a carrier oil with a high flashpoint and low aromatic contents.
- Size: 300g aerosol



Item Code	Bishops Code
198874	32225013

ARDROX® 9D1B NON-AQUEOUS DEVELOPER

- Ardrex® 9D1B is a liquid suspension of an inert white powder in a quick drying solvent
- Low sulphur, halogen and alkali metal content
- Used as developers in penetrant testing of forged parts, welds, cast and drop forged parts
- White
- Size: 300g aerosol



Item Code	Bishops Code
9D1B	32225014

ARDROX® 9PR50C PENETRANT REMOVER

- Ardrex 9PR50 is a colourless, highly volatile, solvent-based penetrant remover
- Low sulphur and halogen content
- Mainly used for the removal of both visible red dye and fluorescent penetrants
- Can also be used as a solvent pre-cleaner prior to the penetrant application for the removal of oil and greases
- Flash point: > 38°C
- Clear
- Size: 300g aerosol



Item Code	Bishops Code
9PR50C	32225015



REPAIR PUTTY & LIQUIDS

FIXMASTER® METAL MAGIC STEEL STICK

- An easy to use, steel-filled compound designed for emergency maintenance repairs on dry or damp surfaces
- The resin and hardener are pre-measured for consistent strength and easy application – simply twist off desired amount, knead and apply
- Cures to a metal-like finish in less than 10 minutes under typical dry service temperatures of -30 to 121°C.
- Suitable for sealing chemical tanks, smoothing welds, pipe and tank leaks, filling oversized bolt holes, repairing holes in elbows cracks in castings and holes in gas and fuel tanks
- Size: 113g



Item Code	Bishops Code
98853	32422030

2K TECH® REPAIR FILLER

- Premium grade 2K body filler
- Creamy texture, minimal pin-holing
- Effortless blading
- Easy sanding
- Compatible with all automotive paint systems
- Size: 4kg



Item Code	Bishops Code
AB2T4	32422820

GELCOAT REPAIR FILLER

- High quality lightweight polyester body filler
- Used to repair chips, scratches and cracks in polyester gelcoats as found on fibreglass boats etc.
- Buttery texture makes it easy to apply with no sag even at high build levels
- The viscosity, gel and cure are strictly controlled to provide consistent quality
- Exhibits excellent adhesion, minimal surface tack, easy sanding and good featheredging
- Cures to a white finish when used with the enclosed hardener
- Not suitable for use below the water line unless the surface is sealed with the appropriate top coat
- Size: 400g



Item Code	Bishops Code
ABG400	32812220

PLASTIC STEEL PUTTY (A)

- Steel filled epoxy for maintenance, repairs, tooling and production applications
- Can be machined, drilled, tapped and painted
- Hardens in about 4 hours, will not shrink, has excellent heat transfer and bonds to a variety of substrates
- Max. temperature: 120°C
- Size: 500g



Item Code	Bishops Code
D10110	32414345

PLASTIC STEEL LIQUID (B)

- Low viscosity steel filled epoxy with similar properties to Plastic Steel Putty but in a liquid form for accurate detail reproduction
- Used for casting low-cost patterns and moulds, holding fixtures, tools and dies
- Low viscosity for easy pouring
- Max. temperature: 120°C
- Size: 500g



Item Code	Bishops Code
D10210	32414340

PLASTIC STEEL 5-MINUTE PUTTY (SF)

- Super fast curing steel-filled epoxy
- For low temperature applications
- Perfect for emergency repairs to metal components required back in service after 1 hour
- Repairs pipes, tanks and other essential equipment
- Max. temperature: 93°C



Item Code	Size	Bishops Code
D10250	250g	32422300
D10240	500g	32422310

ALUMINIUM PUTTY (F)

- Lightweight aluminium filled epoxy
- Aluminium finish
- Non-sagging, non-rusting epoxy putty
- Ideal for rebuilding and repairing aluminium castings, parts and equipment
- Max. temperature: 120°C
- Size: 500g



Item Code	Bishops Code
D10610	32422240

TITANIUM PUTTY

- High performance, titanium reinforced epoxy
- Engineered for making critical repairs to machinery and precision parts
- Rebuilds shafts, keyways and bearing housings
- Wear resistant
- Superior compressive strength
- Max. temperature: 176°C
- Size: 500g



Item Code	Bishops Code
D10760	32422440

CERAMIC REPAIR PUTTY

- Non-sag, trowelable ceramic-filled epoxy compound
- Excellent resistance to corrosion, cavitation, chemicals and erosion
- Repairs processing equipment such as slurry, service water, centrifugal and ash pumps
- Max. temperature: up to 175°C



Item Code	Size	Bishops Code
D11705	500g	32422320
D11700	1.5kg	32422340

FASMETAL 10 (HVAC)

- Aluminium filled, high strength bonding, patching and sealing paste
- Bonds to aluminium and other metals, ceramics, wood, concrete or glass
- Aids in quickly returning equipment back into service
- Suitable for air conditioning repairs
- Max. temperature: 120°C
- Size: 184g



Item Code	Bishops Code
D19770	32422220

FLEXANE 80 PUTTY

- Trowelable urethane that cures to Shore A 87 hardness
- 100% solid, tear resistant and retains its shape under pressure like rubber
- Protects against impact, abrasion, vibration, expansion and contraction
- Repairs and rebuilds conveyor belts, line process equipment to dampen, line concrete control joints
- Max temperature: 82°C
- Size: 450g kit



Item Code	Bishops Code
D15820	32422270

FIBREGLASS REPAIR KIT

- Complete kit to repair large holes and cracks
- Contains Matting, Polyester Resin and Catalyst (MEKP)
- Weather resistant
- Recommended for metal, fibreglass, timber and masonry



Item Code	Bishops Code
ABFR	32428225

CHEM-I-WELD CHEMICAL WELDING COMPOUND

- Permanently seals small cracks and flaws in cylinder heads, blocks and other castings
- Effective on aluminium, cast iron, steel, brass, bronze and copper castings
- Works by hardening on exposure to air in a confined space
- Size: 325ml



Item Code	Bishops Code
13A	32422620

NATURAL RUBBER INSERTION

- Commercial grade cotton reinforced rubber
- Excellent abrasion, flexibility and low temperature resistance
- Used extensively for pipe flanges
- Good resistance to caustics and alkalis
- Smooth finish on both sides
- Width: 1.2m
- 10m roll
- Hardness: Shore A 60-70
- 100% modulus: 24kg/cm²
- Tensile strength: 50kg/cm²
- Elongation at break: 300%
- Tear strength: 12kgf/cm
- Specific gravity: 1.41g/cm³
- Temperature range: -20°C to 75°C



Item Code	Description	Thickness	Bishops Code
75-000-011-010	1 Ply	1.5mm	67080015
75-000-031-010	1 Ply	3mm	67080030
75-000-042-010	2 Ply	4.5mm	67080045
75-000-062-010	2 Ply	6mm	67080060
75-000-092-010	2 Ply	9mm	67080090

FIBREGLASS LAGGING TAPES

- Produced from closely woven or knitted yarns, producing tapes which retain a high degree of softness and flexibility
- Applications include thermal and electrical insulation, gasketing, pipe, hose and valve wrapping, furnace and boiler door seals
- Max. operating temperature: 550°C
- 30m roll

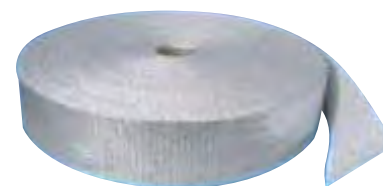

Item Code	Width x Thickness	Bishops Code
083003	25mm x 1.5mm	67050020
083006	25mm x 3.0mm	67050030
083004	50mm x 1.5mm	67050040

FIBREGLASS LAGGING ROPE

- Consists of a low density blown glass fibre core enclosed in a braided cover of glass yarn
- Provides an efficient method of insulating pipe work and is also suitable for a variety of high temperature sealing and caulking applications
- Max. operating temperature: 550°C
- Size: 25mm x 30m



Item Code	Bishops Code
083708	67050520



COMPRESSION PACKING & EXTRACTORS

COMPRESSION PACKING – K10



- Acrylic yarns impregnated with PTFE dispersion
- Economically priced general purpose white packing
- Suitable for use in valves and pumps with water, mild acids and alkalis
- Temperature range: -100°C–260°C
- Max. rotating speed: 10m/s
- Max. dynamic pressure: 30 bar
- Max. static pressure: 100 bar
- 8m roll



Item Code	Size	Bishops Code	Item Code	Size	Bishops Code
191K10030	3.0mm ²	*191K10030	191K10125	12.5mm ²	69067015
191K10050	5.0mm ²	*191K10050	191K10140	14mm ²	69067016
191K10065	6.5mm ²	69067012	191K10160	16mm ²	69067017
191K10080	8.0mm ²	69067013	191K10190	19mm ²	69067018
191K10095	9.5mm ²	69067014	191K10250	25mm ²	69067019

* – SPECIAL ORDER: PLEASE QUOTE ITEM CODE UPON ORDERING THIS PRODUCT

COMPRESSION PACKING – K54F



- A clean non-contaminating packing manufactured from pure PTFE filaments
- Suitable for use in plant wide applications for pumps and valves in virtually all strong acids and alkalis where a high level of resistance to chemical attack is required
- Potable water, food and oxygen service
- Temperature range: -240°C to 260°C
- pH range: 0–14
- Max. rotating speed: 5m/s
- Max. static pressure: 200 bar
- 8m roll



Item Code	Size	Bishops Code	Item Code	Size	Bishops Code
191K54F030	3mm ²	69067041	191K54F125	12.5mm ²	69067046
191K54F050	5mm ²	69067042	191K54F160	16mm ²	69067047
191K54F065	6.5mm ²	69067043	191K54F190	19mm ²	69067048
191K54F080	8mm ²	69067044	191K54F220	22mm ²	69067049
191K54F095	9.5mm ²	69067045	191K54F250	25mm ²	69067050

COMPRESSION PACKING – K11



- Acrylic yarns impregnated with graphite dispersion
- Economically priced general purpose black packing suitable for use in valves and pumps due to its low coefficient of friction
- The graphite enhances its chemical resistance allowing it to effectively seal many forms of chemical media commonly found within today's industrial environments
- Temperature range: -100°C to 300°C
- Max. rotating speed: 20m/s
- Max. dynamic pressure: 30 bar
- Max. static pressure: 100 bar
- 8m roll



Item Code	Size	Bishops Code	Item Code	Size	Bishops Code
191K11030	3.0mm ²	69067024	191K11125	12.5mm ²	69067030
191K11050	5.0mm ²	69067025	191K11140	14mm ²	69067031
191K11065	6.5mm ²	69067026	191K11160	16mm ²	69067032
191K11080	8.0mm ²	69067027	191K11190	19mm ²	69067033
191K11095	9.5mm ²	69067028	191K11250	25mm ²	69067034
191K11110	11mm ²	69067029	–	–	–

COMPRESSION PACKING – K3222



- A high performance valve and pump packing for use in high pressure and high temperature applications
- Manufactured using expanded graphite ribbons to produce a fully flexible, conformable packing with excellent sealing characteristics
- Also available, wire reinforced for higher pressure applications
- Temperature range: -200°C to 430°C (650°C in steam)
- Max. rotating speed: 20m/s
- pH range: 0–14
- Max. static pressure: 100 bar
- 8m roll



Item Code	Size	Bishops Code	Item Code	Size	Bishops Code
1913222030	3mm ²	*1913222030	1913222110	11mm ²	*1913222110
1913222050	5mm ²	*1913222050	1913222125	12.5mm ²	67066998
191K54F065	6.5mm ²	67066992	1913222140	14mm ²	67066999
1913222080	8mm ²	67066994	1913222160	16mm ²	67067000
1913222095	9.5mm ²	67066995	1913222190	19mm ²	67067200

* – SPECIAL ORDER: PLEASE QUOTE ITEM CODE UPON ORDERING THIS PRODUCT

KLINGER STYLE K7302DL – HEAVY DUTY PACKING



- META ARAMID yarn with DOULON lubrication
- Suitable for water, oils, slurry, sewerage, mild acids and alkalis
- An excellent slurry packing for rotating and static applications
- Used in the mining, power generation, pulp and paper and sugar refining industries
- Max. temp.: 280°C
- Max speed: 20m/s
- Max. pressure: 40* bar
- pH range: 2–12
- 8m roll



Item Code	Size	Item Code	Size
1917302DL065	6.5mm ²	1917302DL160	16.0mm ²
1917302DL080	8.0mm ²	1917302DL190	19.0mm ²
1917302DL125	12.5mm ²	1917302DL250	25.0mm ²

SPECIAL ORDER: PLEASE QUOTE ITEM CODE UPON ORDERING THIS PRODUCT

PUMP & VALVE FUGITIVE FUEL EMISSION PACKING – KLINGER STYLE 396 & 396C



- Graphite, Carbon (396) and Inconel wire (396C)
- Style 396 – Suitable for steam, water, caustic and condensate pumps – leak-free performance
- Style 396C – Suitable for steam, boiler feed water, exceeds API requirements – leak-free performance
- Used in the oil and gas, power generation, mining, pulp and paper and sugar refining industries
- Max. temp: 3,000°C+ (Non-oxidizing)
- Min/Max. temp: 200 to 454°C (Oxidizing)
- Max. temp: 650°C (Steam)
- Max. surface speed: 22m/s
- Max. pressure: Style 396 – 175 bar static and 35 bar rotary
- Max. pressure: Style 396C – 345 bar static and 56 bar rotary
- pH range: Style 396 – 0–14 (Except strong oxidisers – Nitric, Oleum, etc)
- pH range: Style 396C – 1–14 (Except strong oxidisers – Nitric, Oleum, etc)



Item Code	Size	Weight	Approx. Length
STYLE 396			
191M396100	10mm ²	1kg	8.8m
191M396130	13mm ²	3kg	18.7m
191M396160	16mm ²	3kg	10m
191M396190	19mm ²	3kg	7.6m
STYLE 396C			
191M396C030	3mm ²	1kg	50.6m
191M396C050	5mm ²	1kg	25.7m
191M396C080	8mm ²	1kg	12.5m
191M396C100	10mm ²	1kg	7.8m

SPECIAL ORDER: PLEASE QUOTE ITEM CODE UPON ORDERING THIS PRODUCT

FLEXIBLE PACKING EXTRACTORS



- High quality packing extractors for use on pumps, valves and other static applications
- Assist in total removal of gland packing without damaging the shaft or the stuffing box
- Flexible shaft is ideal for extracting packing from awkward and hard to reach positions
- Replacement tips available



Item Code	Description	To Suit Packing	Bishops Code
191001	Size 1	6.5–9.5mm	67074015
191002	Size 2	9.5–12.5mm	67074020
191003	Size 3	12.5–16.0mm	67074025
191004	Size 4	16.0mm plus	67074028
K0036075/1	4 Piece Extractor Set		67074030
191005	Replacement Tip to Suit Size 1 Hook		*191005
191006	Replacement Tip to Suit Size 2 Hook		*191006
191007	Replacement Tip to Suit Size 3 Hook		*191007

* – SPECIAL ORDER: PLEASE QUOTE ITEM CODE UPON ORDERING THIS PRODUCT

KLINGERSTATITE AS80.090

- Oil/fuel resistant gasket paper
- Gearbox, carburetors, water pumps
- Temperature range: 0°C to 120°C

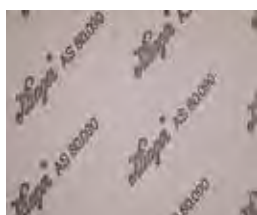

PER METRE

Item Code	Size	Bishops Code
114001	0.2mm x 1m	67020015
114044/1A	0.25mm x 1m	67020025
114045	0.4mm x 1m	67020040
114046/1	0.8mm x 1m	67020080
114047	1.5mm x 1m	67020150
114027	2.4mm x 1m	67020240
114049/1	3.2mm x 1m	67020320

ROLLETTE – 1M

Item Code	Size	Bishops Code
114104	0.4mm x 300mm	67020404
114108	0.8mm x 300mm	67020408
114115	1.5mm x 300mm	67020415

MR 31 PLUS NEO RUBBER CORKS

- Water and oil gasket
- Cork rubber products offer many of the advantages of rubber compounds along with the added benefit of controlled compressibility and recovery
- Highly compressible automotive and general purpose gasket material with moderate oil resistance



SHEET – 1,270 X 762MM

Item Code	Thickness	Bishops Code
119254	1.6mm	67012040
119252	2.4mm	* 119252
119253	3.2mm	67012080
119251	6.4mm	67012100

ROLLETTE – 762 X 300MM

Item Code	Thickness	Bishops Code
110153	1.6mm	67012015
110156	3.2mm	67012030

* – SPECIAL ORDER: PLEASE QUOTE ITEM CODE UPON ORDERING THIS PRODUCT

KLINGERSIL® C4243

- Universal gasket material for general applications
- Suitable for liquids and gases at lower pressure and temperatures
- Good chemical resistance against water and oil
- Max. temperature: 100°C
- Max. pressure: 30 bar
- Sheet size: 1.0 x 1.5m



Item Code	Thickness	Bishops Code	Item Code	Thickness	Bishops Code
767145	0.4mm	67032020	767126	2mm	67032080
767146	1mm	67032040	767128	3mm	67032100
767124	1.5mm	67032060	-	-	-

KLINGERSIL® C4430

- BS7531 Grade X
- AS4020 – Potable water
- A general purpose non-asbestos material offering good resistance to oils, fuels, hydrocarbons, alcohols, lubricants and steam as well as mild acids and alkalis
- Also available wire reinforced
- 3xA anti-stick finish as standard
- Max. temperature: 400°C
- Max. pressure: 40 bar
- Sheet size: 2.0 x 1.5m



Item Code	Thickness	Bishops Code	Item Code	Thickness	Bishops Code
SHEET – 2.0 X 1.5M					
757245	0.4mm	67038101	757224	1.5mm	67038105
757221	0.5mm	67038102	757226	2.0mm	67038106
757246	0.8mm	67038103	757228	3.0mm	67038107
757222	1.0mm	67038104	-	-	-
SHEET – 1.0M X 300MM					
757945	0.4mm	67030004	757924	1.5mm	67030015
757946	0.8mm	67030008	-	-	-

WIRE REINFORCED STEAM GASKETS – TG2008



- TOPgraph 2008 sheet
- The flexible graphite sealing material with a high degree of inherent stability
- It has high load bearing capacity combined with high seal ability
- Ideally suited for use with steam and other critical applications
- Grade TG2008 is wire reinforced
- Max. temperature: 500°C
- Max. pressure: 100 bar
- Sheet size: 1.0 x 1.5m

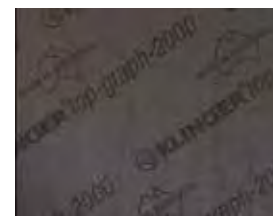

Item Code	Thickness	Bishops Code	Item Code	Thickness	Bishops Code
562008108	0.8mm	67038020	562008120	2.5mm	67038050
562008110	1.0mm	67038025	562008130	3.2mm	67038060
562008115	1.5mm	67038040	-	-	-

KLINGER® SOFTCHEM R



- A multi-directional, 100% expanded PTFE sheet gasket material
- The best choice for sealing uneven and damaged flanges
- Easy to cut and install and requires low compressive loads to seal
- Virtually compatible with all media across the PH range
- Max. temperature: 230°C
- Max. pressure rating: 40 bar
- Sheet size: 1.5m x 1.5m



Item Code	Thickness
551150015	1.5mm
551150030	3.0mm

SPECIAL ORDER: PLEASE QUOTE ITEM CODE UPON ORDERING THIS PRODUCT

SOFT CUT METALLIC & SEMI-METALLIC & GRAPHITE LAMINATED GASKETS

Available on request, manufactured from various materials to standard and non-standard sizes

- Raised face or Full face gaskets cut from KlingerSil sheeting to all international standards and non-standard gasket sizes
- Maxiflex Spiral Wound Gaskets – Type R, CR RIR and CRIR
- Maxiprofile Gaskets – Kammprofile – T108 and T109 Heat exchanger gaskets
- Metallic Ring Joints (RTJ) – Type R Oval and Octagonal – Type RX and BX
- Graphite laminated gaskets – PSM – Graphite with metal insert
- Metal jacketed (clad) gaskets - All shapes and sizes for heat exchangers



CONTACT YOUR BISHOPS REPRESENTATIVE FOR MORE INFORMATION

GET MORE AT BISHOPS



GASKET SEALANT

Page 466



QUICK GUIDE

Here's a quick guide to the difference between instant adhesives and epoxy adhesives.

They are both chemically curing, meaning that they harden through chemical reaction.

Instant Adhesives are in single component form where the hardening agent is often an external catalyst such as moisture. Most instant adhesives are cyanoacrylate based which cures through evaporation.

Epoxy comes in two component form, kept separate until hardening is required. When they are mixed together, the catalyst for hardening occurs to bond two surfaces together.

LOCTITE 401 INSTANT ADHESIVE

- 401 is a low viscosity, fast curing, cyanoacrylate adhesive
- This product is less dependant on surface moisture for cure speed than other standard CA grades
- Can be used with PP primer 770 for polyolefin bonding.
- Suitable for rapid bonding of metal, plastic, rubber, cork, wood, paper, leather, fabric etc.
- Unique chemistry ensures rapid cure even on difficult to bond substrates (may require priming)
- Size: 25ml



Item Code	Bishops Code
40124-25	32414040

LOCTITE 406 INSTANT ADHESIVE

- High strength cyanoacrylate adhesive for bonding difficult materials. Rapid bonding of wood, leather, metal, plastic, rubber, cork, fabric, paper and ceramics
- Fixes very fast, even on difficult to bond substrates (may require priming)
- Low viscosity
- Fast fix time of 2-30 seconds
- Cure colour: Clear
- Service temperature: -40°C to 120°C



Item Code	Size	Bishops Code
40633-25	25ml	32414110
40633-100	100ml	32414050

LOCTITE 454 INSTANT ADHESIVE GEL

- Cyanoacrylate adhesive with gel consistency for bonding difficult and porous substrates even on vertical surfaces. Superior gap filling ability up to 0.25mm (0.010").
- Suitable for rapid bonding of metal, plastic, rubber, cork, wood, paper, leather, fabric and more
- No run, no drip
- Fast fix time of 2-60 seconds
- Size: 20g



Item Code	Bishops Code
A045416	32414090

LOCTITE 3801 FIVE MINUTE EPOXY ADHESIVE

- Fast setting, two component industrial grade epoxy adhesive
- High strength and general purpose
- Cures at room temperature and forms a clear bondline
- When fully cured, the epoxy is resistant to a wide range of chemicals and solvents, and acts as an excellent electrical insulator
- Suitable for general purpose bonding of wood, metals, ceramic, concrete, marble, glass, china, fibreglass and laminates
- Size: 25ml



Item Code	Bishops Code
20981	32414020

5 MINUTE EPOXY ADHESIVE

- Rapid-curing general purpose adhesive
- Bonds surfaces such as metals, glass, ceramics, concrete and wood
- Functional cure: 45 minutes
- Working time: 4 minutes
- Cure colour: clear
- Service temperature: -4°C to 90°C
- Size: 28.4g



Item Code	Bishops Code
DS-208	32414325

ARALDITE® EPOXY ADHESIVE

- Two part epoxy adhesives
- Bonds a variety of surfaces
- Forms a rigid, durable bond
- Gap filling properties
- Dries clear
- 5 Minute Everyday**
 - Quick setting
 - Moderate water resistance
- High Strength**
 - Initial bonding achieved in 6-8 hours
 - High shear and peel strength
 - Very high water and weather resistance



Description	Size	Bishops Code
5 Minute	35ml	32414295
High Strength	200ml	32414298

PLASTIC STEEL EPOXY

- High strength bond (17MPa, 2,500psi) bonds to itself and other metals
- Ideal for use with metal, steel, aluminium, copper, iron and pewter
- Excellent for filling under speedy sleeves or where heat transfer is critical
- Service temperature: 40°C wet or 120°C dry
- Cure time: 60mins
- Bond time: 16hrs



Item Code	Bishops Code
DS-5	32414305

WHAT IS A BONDING ADHESIVE?

Bonding adhesives, unlike chemical curing adhesives, already exist in their final chemical form. To keep these adhesives from hardening, different solvents, both chemical and water based, are used. After application, the solvent evaporates, allowing the adhesive to cure.

Solvents are potentially harmful chemicals. When used in adhesives they produce a strong intermediate bond allowing the bonding surfaces to be moved for a short period of time before the adhesive cures. After curing, the adhesive remains slightly flexible. The harmful chemicals ("VOCS") used in solvents can potentially damage the surrounding environment, so be sure to check the manufacturer's SDS.

Solvent-Free adhesives, typically water based, work in a similar way. To classify as a solvent-free adhesive, the chemical makeup must consist of less than 5% solvent. Being generally water based, these adhesives bond better to porous and semi-porous surfaces such as wood, paper, fabric and leather.

LIQUID NAILS CONSTRUCTION ADHESIVE

- General purpose construction adhesive
- Has a high strength bond to most building materials and is polystyrene safe
- Gun style application makes it easy to use
- Suitable for both interior and exterior applications
- Ideal for most industrial and household materials such as steel, sheet metal, timber, plasterboard, ceramics and more
- Beige



Size	Bishops Code
320g	32414230

CONTACT BOND ADHESIVE

- Solvent-based contact adhesive
- Extra strong and flexible bond
- Easy to apply with brush or scraper
- Water and heat resistant
- Suitable for use on most natural and neoprene rubbers as well as porous and non-porous surfaces



Size	Bishops Code
1L	32414200

KWIK GRIP HORIZONTAL CONTACT ADHESIVE

- Strong and durable adhesive ideal for horizontal surfaces
- Easy to apply and no running or stringing
- Suitable for interior and exterior jobs
- Heat resistant up to 130°C
- Water resistant
- Size: 4L



Item Code	Bishops Code
9300697102256	32414170

PLASTIC WELDER

- Toughened structural adhesive formulated for bonding dissimilar substances
- Highly resistant to hydrocarbon fuels
- Bonds PVC, fibreglass, ABS, steel, acrylics, polycarbonate, polyesters (PET, PBT), wood and ceramics
- Cure colour: cream
- Service temperature: -55°C to 120°C
- Size: 28.4g



Item Code	Bishops Code
DS-220	32414335

AA 324 HIGH IMPACT STRUCTURAL ADHESIVE

- A high impact, toughened, two step acrylic, no mixing required, amber, multi-surface structural adhesive
- Loctite 324 is solvent resistant and, when used in conjunction with Loctite Primer 7075, is ideal for large gap applications
- Loctite 324 offers the strength of an epoxy and the speed of an instant, fixturing in 5 minutes
- Size: 50ml



Item Code	Bishops Code
32430	32420190

STICKY STUFF

Did you know that the drying time for bonding adhesive sprays depends heavily on the solids content?

High Solids Content means that the spray takes longer to dry, allowing time for bonding materials to be moved into position before curing.

Low Solids Content means that the spray will dry very quickly, which may be more important to you.



BONDING ADHESIVES, RETAINING COMPOUNDS & PRIMERS

PVC PIPE SOLVENT CEMENT

- PVC solvent is suitable for use in pressure applications, including potable water



Size	Colour	Bishops Code
250ml	Blue	32414250
500ml	Blue	32414255
500ml	Green	32414258

RED PVC PRIMING FLUID

- Cleans and primes PVC pipes, fittings and sheeting



Size	Bishops Code
500ml	32414266

RETAINING COMPOUNDS

- Loctite Anaerobic Retaining Compounds can be used to augment or replace traditional interference fits for cylindrical components
- They increase assembly strength
- Prevent fretting corrosion and backlash
- Reduce assembly cost
- Can be used to reclaim worn parts



Product Code	Description	Colour	Max. Gap Fill	Temperature Range	Size	Bishops Code
30013					10ml	32420240
30015	Loctite 609 Retaining Compound – Medium/high strength for metal pulleys, sprockets, sleeves, couplings, bearings, etc. Dismantles with press or pullers	Green	0.2mm	-54 to 150°C	50ml	32420250
30014					250ml	32420252
62050	Loctite 620 Retaining Compound – High Strength – High temp (230°C)	Green	0.25mm	-54 to 230°C	50ml	32420260
63531	Loctite 635 Retaining Compound – Very High Strength – Slow cure. Ideal where time is required for assembly	Green	0.2mm	-54 to 150°C	50ml	32420270
21314	Loctite 641 Bearing Mount – Medium Strength – Ideal for parts that require disassembly.				10ml	32420050
45079	Can be used in slip, press or shrink fits to prevent unwanted movement & fretting corrosion.	Yellow	0.2mm	-54 to 150°C	50ml	32420060
45081	Applications: mounting bearings, bushes, sleeves, seals, valve guides, woodruff keys & liner assemblies				250ml	32420070
66010A	Loctite 660 Quickmetal® – High Strength Press Fit Repair – Gap filling paste. Repairs worn shafts or housings, keyways, splines & creates form in place shims	Silver	0.5mm	-54 to 150°C	50ml	32422020
1800574	Loctite 680 Retaining Compound – Very High Strength – Fast cure for slip fit assemblies. High load transmitting grade for permanent assemblies, e.g. earth moving, mining equipment	Green	0.2mm	-54 to 180°C	50ml	32420280

LOCTITE 770 PP PRIMER

- 770 Polyolefin Primer is a single component material which dries rapidly at room temperature
- Enables polyolefin and other low energy surfaces suitable for bonding with Loctite cyanoacrylate adhesives
- Size: 100ml



Item Code	Bishops Code
29520A	32420315

LOCTITE 7471 PRIMER

- Primer designed to speed the cure of Loctite anaerobic adhesives and sealants.
- Use where gaps slightly exceed normal recommendations
- Use when accelerated cure speed is required in cold weather or on inactive metals
- Note: not a cleaner/degreaser
- Size: 133ml



Item Code	Bishops Code
22477	32420310

JOINTING TIPS

Looking to get the best finish possible? Take a look at some of our handy tips!

Tape both sides of the gap before applying the jointing compound. Simply remove the tap afterwards for straight edges. Check out Bishops' range of tapes starting on page 346.



Extrude a small amount of compound onto scrap material to ensure a smooth and consistent finish. Don't have scrap material laying around? Get yourself a bag of rags on page 403.

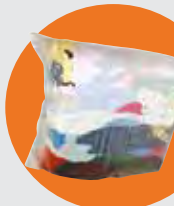

Allow surfaces to skin before painting. It takes approximately 30 minutes depending on the conditions for jointing compound to skin. Check OEM specifications before painting. You can find paint starting on page 354.

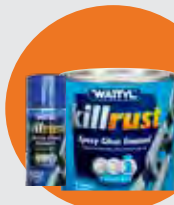

Do you need help choosing the right jointing compound for your application? Or maybe you just need some advice? Whatever you need,

Just ask Bishops!

HYLOMAR GASKET JOINTING COMPOUND

- Sealing adhesive spray
- Withstands high temperatures
- Resistant to most fuels
- Suitable for use on most gaskets and metals, sumps, pumps, valves, hydraulic and pneumatic assemblies, gearboxes, cylinder heads and axles
- Size: 300g aerosol



Item Code	Bishops Code
HYL200	32418050

STAG JOINTING COMPOUND

- An oil-proof, petrol-proof and waterproof anti-corrosive compound
- Suitable for air and steam lines, diesel engines and hydraulic equipment
- Size: 200g tube



Item Code	Bishops Code
SG200	32418060

GAP FILLER

- Multi-purpose gap filler
- Suitable for indoors and outdoors
- Water-based formula allows for easy clean up
- High flexibility and a longer lasting result
- White
- Size: 475g



Size	Bishops Code
475g	32424235

GAP FILLER

- Acrylic caulk
- Water-based formula
- Suitable for interior and exterior applications
- Can be painted over once fully set with oil-based or other types of paints
- White



Size	Bishops Code
450g	32424230

PU EXPANDING FOAM

- Universal use
- Fast curing
- Strong adhesion
- No shrinkage once hardened
- High thermal and acoustic insulation
- Makes up to 50L
- Size: 750ml



Item Code	Bishops Code
MPU-M50	32424500

SIKABOOM AP

- High yield, polyurethane expanding foam
- Excellent adhesion and insulation properties
- Rapidly and economically fills large voids and blocks out dust, noise, draft and vermin
- Cuttable, sandable and paintable, all in a multipositional, all directional can
- Size: 750ml aerosol



Item Code	Bishops Code
411946	32424336



JOINTING/CHOCKING COMPOUNDS & SILICONE SEALANTS

DENSO™ PROFILING MASTIC

- Self-supporting, lightweight and flexible mastic for all sealing, filling and caulking purposes
- Used to fill awkward angles prior to wrapping with Denso™ Petrolatum Tapes or Bitumen Tapes
- For use on mechanical joints, flanges, fittings and valves
- Weight for weight Denso™ Profiling Mastic will fill three times the volume filled by other brand mastics due to its low density
- Comes in block form
- Size: 3.5kg



Item Code

P410100-44

SPECIAL ORDER: PLEASE QUOTE ITEM CODE UPON ORDERING THIS PRODUCT

DENSOSEAL 16A™

- A non-setting, self-supporting mastic which can be applied to wet surfaces and is designed for sealing ducts and conduits against the ingress of gas and water
- Can easily be applied by hand and is ideal for sealing ducts and conduits that are below ground level and susceptible to infiltration by water or gas
- Can also be used to create smooth profiles around awkwardly shaped mechanical joints on hot pipes prior to the application of a protective tape wrap system
- 8 units per carton
- Size: 1kg



Item Code

M450001

SPECIAL ORDER: PLEASE QUOTE ITEM CODE UPON ORDERING THIS PRODUCT

ADHESIVE SILICONE SEALANT

- Single component adhesive silicone sealant
- Suitable for general industrial purposes including metal fabrication, sealing dissimilar metal surfaces, glass to metal and joints in cement and metal pipes
- Very high and wide temperature tolerance, ozone and weather resistance
- Cure: neutral, non-corrosive
- Service temperature: -65°C to 232°C
- Size: 310g cartridge



Item Code

310G1080CL

Bishops Code

32424165

SILASTIC 732 RTV

- Premium multi-purpose sealant
- Single component silicone sealant with no mixing required
- FDA approved
- Waterproof and resistant to a wide range of temperatures



Colour

Size

Bishops Code

Clear	139ml Tube	32424010
Clear	310g Cartridge	32424020
White	139ml Tube	32424040
White	310g Cartridge	32424050
Black	139ml Tube	32424060
Black	310g Cartridge	32424070

SILASTIC 736 RTV SEALANT

- Heat resistant sealant
- Used for sealing and bonding applications at high temperatures
- Suitable for work on heaters, ovens, smoke stacks, gas appliances and duct work
- Temperature range: -65°C to 315°C
- Red/white
- Size: 90ml/85g



Item Code

90ML736RED

Bishops Code

32424110

SILASTIC 738 RTV SEALANT

- Electrical sealant
- Ideal for bonding and sealing corrosion-sensitive electrical and electronic equipment
- Temperature range: -62°C to 180°C
- White
- Size: 90ml/85g



Item Code

90ML738WHITE

Bishops Code

32424130

RTV 926 SILICONE ADHESIVE SEALANT

- A single component, neutral cure sealant
- Cures quickly to a consistent silicone rubber that remains flexible and durable
- Has a high level of adhesion to most surfaces and can withstand a large range of chemicals and temperatures, making it ideal for industrial applications
- Translucent



Size

300g

Bishops Code

32424030

S6 SANITARY KITCHEN & BATHROOM SEALANT

- One component, non-flowing neutral cure, mid modulus silicone sealant
- Contains an effective fungicide to reduce the growth of mold and mildew
- Offers excellent adhesion to powder coated metal
- Service temperature: -50°C to 150°C
- Size: 300gm



Colour

Gloss White
Transparent

Bishops Code

32424312
32424314

PLUMBING ROOF & GUTTER SILICONE

- Neutral cure
- Single component RTV silicone
- Suitable for all types of roofing, guttering and weatherproofing jobs
- Can be used on various metals, ceramics, concretes, painted surfaces and rain water tanks
- Transparent



Size	Bishops Code
300g	32424240

SIKASIL AP

- Multi-purpose roof and gutter silicone sealant
- Adheres to polycarbonates
- Size: 300ml cartridge



Item Code	Colour	Bishops Code
407717	Black	32424331
405663	White	32424334

RTV 936 HIGH PERFORMANCE HIGH TEMPERATURE SEALANT

- High temperature industrial silicone sealant
- One component
- 100% silicone rubber
- Suitable for Industrial applications where high heat resistance is required
- For use on industrial ovens and boilers, domestic cookers and ovens, sealing and encapsulating heating elements in appliances, flues on gas appliances, household electrical and industrial heating equipment, smoke stacks and moving oven belts



Size	Bishops Code
300g	32424120

INDUSTRIAL GRADE WEATHERPROOF NEUTRAL CURE SILICONE

- Suitable for sealing and adhering a wide variety of products and surfaces plus glazing and weather seal applications
- Single component silicone sealant
- Waterproof, UV resistant, low odour and fast drying
- Cure: neutral, non-corrosive
- Service temperature: -62°C to 180°C
- Colour: clear



Size	Bishops Code
300g	32424318

SIKASIL INDUSTRIAL SILICONE SEALANT

- Silicone adhesive sealant
- Neutral curing
- Fast curing and low odour
- UV and weather resistant, suitable for outdoor use
- Suitable for sealing joints in wet areas, gutters, skylights and general glazing
- Size: 300ml cartridge



Item Code	Bishops Code
525357	32424325

GET MORE AT BISHOPS



STEPS & LADDERS

From Page 359

SEALANT SEAL'N'FLEX 1

- Suitable for all common construction materials including concrete, brick, plasterboard, aluminium windows, granite, marble and fibreglass
- Single component polyurethane sealant
- Resistant to normal weathering conditions such as rain, sunlight, snow, sleet, ozone, atmospheric contamination and pollution
- Approved for use with drinking water
- Neutral, non-corrosive cure
- Service temperature: -40°C to 70°C
- Size: 300ml Cartridge



Description	Bishops Code
Black	32424306
White	32424307

SIKAFLEX-11FC

- Multi-purpose sealant/adhesive
- Approved for use in potable water
- Size: 310ml cartridge



Item Code	Colour	Bishops Code
134182	White	32424300
134183	Black	32424302



POLYURETHANE & GASKET SEALANTS

SIKAFLEX-PRO

- Multi-purpose polyurethane sealant
- Suitable for construction jobs
- Available in 10 colours
- Size: 600ml sausage



Item Code	Bishops Code
90387	32424330

SIKAFLEX TANK

- Polyurethane joint sealant, ideally suited to contaminated water and high chemical environments
- Suitable for use in facilities for storage, filling and handling of contaminated water and other liquids
- For sealing joints in water retaining structures including sewage, water treatment, filtration and aerating tanks
- Size: 600ml sausage
- Grey



Item Code	Description	Bishops Code
156879	SikaFlex Tank 600ml Sausage	32424335
156879 + 494957	SikaFlex Tank 600ml Kit With Nozzle	32424339

SIKAFLEX-255 EXTRA

- Windscreen adhesive
- Single component polyurethane adhesive
- Paintable and non-corrosive
- Size: 310ml cartridge
- Black



Item Code	Bishops Code
92010	32424310

SIKAFLEX 292I

- Single component polyurethane adhesive
- Assembly adhesive ideally suited to marine environments, with high resistance to fresh and sea water
- Elastic with good gap filling properties and can be overpainted
- Bonds well to a variety of substrates
- White



Item Code	Description	Bishops Code
409802	SikaFlex 292i 310ml Cartridge	32424320
409800 + 494957	SikaFlex 292i 600ml Kit With Nozzle	32424321

SIKAFLEX PRO CONCRETE PU JOINT SEALANT

- Single component polyurethane-based joint sealant
- Excellent adhesion to cement based materials, brick ceramics, polyurethane, epoxy and more
- Good weather resistance
- Suitable for construction jobs
- Non-corrosive
- No mixing required
- Can be painted over
- Size: 600ml sausage with nozzle
- Grey



Item Code	Bishops Code
519842 + 494957	32424338

GET MORE AT BISHOPS



UTILITY KNIVES

Page 228

KLINGER® SEALEX

- Manufactured from 100% virgin PTFE by a unique process
- The resulting product is soft, compressible and highly conformable self adhesive sealing tape
- The best choice for sealing uneven, thin and damaged flanges
- Ideal as an emergency gasket or economical solution to sealing large diameter flanges and tank lids
- Easy to cut to length and install and requires low compressive loads to seal
- Compatible with all media across the pH range
- Max. temperature: 260°C
- Max. pressure rating: 50 bar



Item Code	Thickness x Length	Bishops Code	Item Code	Thickness x Length	Bishops Code
886803	3mm x 30m	*886803	886813	12.5mm x 5m	67038135
886805	5mm x 23m	67038132	886816	16mm x 5m	67038136
886806	7mm x 15m	67038133	886819	19mm x 5m	67038137
886810	10mm x 7.5m	67038134	886820	25mm x 5m	67038138

* - SPECIAL ORDER: PLEASE QUOTE ITEM CODE UPON ORDERING THIS PRODUCT

5920 PREMIUM COPPER SILICONE – GASKET MAKER/SEALANT



- Single component silicone gasket and flange sealant
- Suitable for flexible flanges and gaskets with gaps up to 1mm operating in very high temperature environments
- Low odour, volatility and is sensor safe with good electrical insulation
- Cure: neutral, non-corrosive
- Service temperature: -54°C to 371°C
- Size: 85g tube



Item Code	Bishops Code
287437 - Loctite 5920	32412275



GASKETING SEALANT

- Loctite Flange Sealants can be used to replace gaskets or help gaskets seal
- Loctite Anaerobic Flange Sealants are ideal for small gaps on rigid flanges
- Loctite Silicone Flange Sealants suit gaps up to 6mm on flexible gasket faces and offer outstanding oil resistance
- Loctite Maxx silicones are neutral cure (prevent corrosion), sensor safe and exhibit outstanding hot oil resistance



Item Code	Description	Max. Gap Fill	Temperature Range	Size	Bishops Code
45077	Loctite 510 Gasket Eliminator® – Rigid anaerobic gasketing material for high temp, high chemical resistance. Suitable for highly stressed gearboxes & motors. Adds structural rigidity & eliminates gasket compression set	0.25mm	-54 to 200°C	250ml	32412190
51531A	Loctite 515 Master Gasket® – Flexible anaerobic gasketing material for rigid, machined metal flanges. Eliminates paper, rubber & cork gaskets. Used for pumps, thermostat housings, transmission covers, etc	0.5mm	-54 to 150°C	50ml 300ml	32412200 32412210
51827	Loctite 518 Gasket Eliminator® – Flexible anaerobic gasketing material for alloy parts. For sealing rigid metal flanges against leakage & movement. Recommended for alloy flanges e.g. aluminium gearbox & engine castings	0.25mm	-54 to 150°C	25ml 300ml	32412220 32412230
34848	Loctite 587 Blue Maxx® Silicone – Non-corrosive, low odour, highly flexible, oil resistant, sensor safe. Ideal for inspection covers & gear boxes & where movement causes failure of regular gaskets	6mm	-60 to 260°C	95g 300ml	32412270 32412272
59630	Loctite 596 Superflex® Red – RTV Silicone Sealant – High temperature, viscous, low volatile product, emits small amounts of acetic acid during cure. Sensor safe. Applications include inspection plates, boilers, exhaust ducts, etc. Replaces cork or rubber	6mm	-60 to 315°C	80ml	32412280
20166	Loctite 5900 Heavy Bodied Silicone – Outstanding oil resistance. Fast cure, resists blow-out. Neutral cure, sensor safe. Replaces cork and paper, suits stamped metal covers, sumps, etc.	6mm	-54 to 232°C	300ml	32420235
30514	Loctite #2 Gasket Sealant – Non-hardening, slow dry, flexible cure. Compatible with: cork, metal, plastic & rubber	0.1mm	-54 to 205°C	85g	32412020
3JA	Loctite #3 Aviation Gasket Sealant – Slow drying, non-hardening solvent sealant.	0.1mm	-54 to 205°C	50ml	32412050
30516	Suitable for close fitting machined surfaces, sealing hoses & dressing gaskets	0.1mm	-54 to 205°C	473ml	32412040
4J	Loctite #4 Hard Setting Gasket Cement – Hard setting bottle, petrol & oil resistant. For threaded connections, manifold, coating differential cover, thermostat housing & water pump gaskets	0.2mm	-55 to 170°C	50ml	32412060

THREAD SEALANTS

- Loctite Anaerobic Thread Sealants prevent leakage of fluids and gases from threaded joints
- They offer the ability to seal fittings in any position and can achieve an instant moderate pressure seal



Product Code	Description	Colour	Max. Thread Diameter	Temperature Range	Size	Bishops Code
56747A	Loctite 567 Pipe Sealant – Controlled Strength – High Temp – Ideal for coarse metal threads where slow cure allows adjustment of fittings. Gas approved (AGA Certificate 3207, 1,050kPa)	White	75mm	-54 to 205°C	50ml 250ml	32412250 32412260
19259	Loctite 577 High Pressure Pipe Sealant – Medium Strength – Fast Cure – Ideal for coarse metal threads where high locking strength is required. Approved for potable water (AS/NZS 4020) & gas (AGA Certificate 4787 to 2,600kPa)	Yellow	75mm	-54 to 150°C	50ml 250ml	32412245 32412248
56950	Loctite 569 Hydraulic Sealant – Low Strength – Fast Cure – Recommended for fine threaded fittings as used in hydraulic & pneumatic applications	Brown	17mm	-54 to 150°C	50ml 250ml	32420220 32420230

GET MORE AT BISHOPS ▶



PAINT BRUSHES

Page 356



GLOVES

Page 10



THREADLOCKERS, CAULKING GUNS & APPLICATORS



THREADLOCKERS

- Loctite Anaerobic Threadlockers prevent loosening due to vibration
- Prevents seal threads against leakage and corrosion
- Provide controlled lubrication for correct torque – tension relationship (clamp load)



LUBRICANTS, SEALANTS & CHEMICALS

Product Code	Description	Strength	Colour	Temperature Range	Size	Bishops Code
22220	Loctite 222 Screw Lock Threadlocker – Best strength for screws & small fasteners. Will undo with normal tools. Also use on low strength metals such as aluminium which can break during disassembly	Low	Pink	-55 to 150°C	10ml	32420020
22250					50ml	32420030
45083					250ml	32420040
44089	Loctite Best Ever 243 Threadlocker – Best strength for nuts & bolts, undo with hand tools. Improved oil tolerance, cure on passive metals & heat ageing. Eliminates backlash in keyways	Medium	Blue	-55 to 180°C	10ml	32420080
44092					50ml	32420090
44094					250ml	32420100
44279	Loctite Best Ever 263 High Strength Threadlocker – Best strength for large fasteners & studs. Improved oil tolerance, cure on passive metals & heat ageing. May require heat to remove	High	Red	-55 to 180°C	10ml	32420110
44130					50ml	32420140
44131					250ml	32420150
27750	Loctite 277 Threadlocker – Very high strength & chemical resistance. Very high viscosity for threads to 50mm in severe operating conditions. Outstanding chemical resistance. Heat may be required for disassembly	High	Red	-55 to 150°C	50ml	32420160
29020A	Loctite 290 Wick In Medium Strength – Very low viscosity grade for post assembly applications, e.g. adjustment screws. Wicks in by capillary action. Fast cure, excellent chemical resistance. Also seals porosity	Med-High	Green	-55 to 150°C	10ml	32420170
45076					50ml	32420180

COMPACT FOAM GUN APPLICATOR

- For use with fire rated foam cartridges
- Nylon multi use
- Plastic screw top



Item Code	Bishops Code
MUCMPPHO	32424515

CAULKING GUN

- Easy trigger action
- Suits both sausages and cartridges
- 370mm barrel
- Capacity: 600ml



Item Code	Bishops Code
182102	62520220

CAULKING GUN

- Suitable for use at home or in the workplace
- Skeleton style
- Features finger guard for comfort
- Big ladder hook
- Suits 310ml cartridges
- Pistol rod diameter: 7.8mm



Item Code	Bishops Code
LY-G2-01-CSR	62520020

SIKAFLEX SAUSAGE NOZZLES

- Tapered design
- Suitable for all Sikaflex sausages
- Easily cuttable
- 3 per pack



Item Code	Bishops Code
494957	32424340



Bishops Stock & Sell:

- Clothing & Footwear
- Safety Equipment & Consumables
- Material Handling & Lifting Equipment
- Hand & Cutting Tools
- Welding & Abrasives
- Power & Pneumatic Tools
- Machinery & Construction Equipment
- Lubricants, Sealants & Chemicals
- Janitorial & Hygiene Products
- General Industrial Products
- Fasteners
- Bearings, Seals & Transmission Products
- Hydraulics, Valves, Hoses & Fittings
- Offshore Oil & Gas Products

With access to over 200,000 products, Bishops has everything you need. See in store today.



SALES & SERVICE

PORT MORESBY
LAE
KIMBE

325 1088
472 3799
983 5500

MADANG
MT HAGEN
KOKOPO

422 1344
545 1990
982 9911

sales@bishopbro.com.pg
www.bishopbro.com.pg





12

HYDRAULICS, VALVES, HOSES & FITTINGS

HYDRAULICS

Hydraulic Cylinders	472
Hydraulic Pumps.....	473-474
Hydraulic Torque Wrenches	474-475
Hydraulic Hoses & Couplers.....	475
Hydraulic Gauges & Adaptors	476

HOSE, REELS & ACCESSORIES

Hose Reel Assemblies	476-477
Bare Hose Reels.....	478
PVC Hose.....	479
Rubber Hose.....	480-481
Nylon Hose & Tubing	481
Hose Assemblies.....	482
Claw Couplings, Seals & Whipchecks	483-484
Camlocks.....	484-485
Hose Clamps, Bands & Buckles.....	486
Copper Tubing.....	487

FITTINGS

Push-In Tube Fittings	492
Air Hose Fittings	493
Brass & Stainless Steel Hose Fittings.....	494
Brass Pipe Fittings	495
Flare & Galvanised Pipe Fittings	496
Stainless Steel Pipe Fittings	497-498
Black Steel Pipe Fittings.....	498-499

VALVES & FLOW CONTROL

Ball Valves.....	500-501
Gate Valves.....	501
Pressure Gauges	502-503
Air Filters, Regulators & Lubricators	503-504
Drain Valves.....	504

FLANGES

Blind Flanges.....	506
Slip-On Flanges.....	506



HYDRAULIC CYLINDERS

RC-TRIO SERIES SINGLE ACTING HYDRAULIC CYLINDERS

- Standard certified lifting eyes on cylinder models above 25kg weight
- Interchangeable with optional CHM6 carrying handle
- Heavy duty, durable and corrosion resistant
- CR400 coupler and dust cap included on all models
- Max. pressure: 10,000psi (700bar)
- 50, 75 and 100T capacity cylinders also available



ENERPAC

Item Code	Capacity	Stroke	Collapsed Height	Weight	Bishops Code
RC50	5t	16mm	41mm	1.0kg	*RC50
RC51	5t	25mm	110mm	1kg	*RC51
RC53	5t	76mm	165mm	1.5kg	*RC53
RC55	5t	127mm	215mm	1.9kg	*RC55
RC57	5t	177mm	273mm	2.4kg	*RC57
RC59	5t	232mm	323mm	2.8kg	*RC59
RC101	10t	26mm	89mm	1.8kg	*RC101
RC102	10t	54mm	121mm	2.3kg	*RC102
RC104	10t	105mm	171mm	3.3kg	77080600
RC106	10t	156mm	247mm	4.4kg	77080605
RC108	10t	203mm	298mm	5.4kg	*RC108
RC1010	10t	257mm	349mm	6.4kg	77080615
RC1012	10t	304mm	400mm	6.8kg	*RC1012
RC1014	10t	356mm	450mm	8.2kg	*RC1014
RC151	15t	25mm	124mm	3.3kg	*RC151
RC152	15t	51mm	149mm	4.1kg	*RC152
RC154	15t	101mm	200mm	5kg	*RC154
RC158	15t	203mm	322mm	8.2kg	*RC158
RC1510	15t	254mm	373mm	9.5kg	*RC1510
RC1512	15t	305mm	423mm	10.9kg	*RC1512
RC1514	15t	356mm	474mm	11.8kg	*RC1514
RC251	25t	26mm	139mm	5.9kg	*RC251
RC252	25t	50mm	165mm	6.4kg	77080625
RC254	25t	102mm	215mm	8.2kg	77080630
RC256	25t	158mm	273mm	10kg	77080635
RC258	25t	210mm	323mm	12.2kg	*RC258
RC2510	25t	261mm	374mm	14.1kg	*RC2510
RC2512	25t	311mm	425mm	16.3kg	*RC2512
RC2514	25t	362mm	476mm	17.7kg	*RC2514

* - SPECIAL ORDER: PLEASE QUOTE ITEM CODE UPON ORDERING THIS PRODUCT

FAST FACTS CALCULATING HYDRAULIC PUSH/PULL

If you're unsure of how much force your hydraulic cylinder produces, use this easy calculation to find out!

$$\text{Push (lbs)} = \frac{\text{Pressure (psi)} \times \pi \times b^2}{4}$$

$$\text{Pull (lbs)} = \frac{\text{Pressure (psi)} \times \pi \times (b^2 - d^2)}{4}$$

$\pi = 3.14$ $b =$ Bore of a cylinder (inches) $d =$ Diameter of the rod (inches)

LOW HEIGHT HYDRAULIC CYLINDERS ENERPAC

- Heavy duty, durable and corrosion resistant
- Low profile compact design for confined spaces
- CR400 coupler and dust cap included on all models (RSM50 is fitted with an AR400 coupler)
- Max. operating pressure: 10,000psi (700bar)

RSM-Series – Flat-Jac Cylinders:

- Mounting holes permit easy fixturing
- Grooved plunger ends require no saddle
- RSM750, 1000, 1500 have handle for easy carrying

RCS-Series – Low Height Cylinders:

- Grooved plunger end with threaded holes for mounting tilt saddles
- Integral handle on RCS1002



Item Code	Capacity	Stroke	Collapsed Height	Weight	Bishops Code
RSM-SERIES					
RSM50	5t	6mm	32mm	1kg	77080650
RSM100	10t	11mm	43mm	1.4kg	77080655
RSM200	20t	11mm	51mm	3.1kg	77080660
RSM300	30t	13mm	58mm	4.5kg	77080670
RSM500	45t	16mm	66mm	6.8kg	*RSM500
RCS-SERIES					
RCS101	10t	38mm	88mm	2.7kg	77080700
RCS201	20t	45mm	98mm	5kg	77080710
RCS302	30t	62mm	117mm	6.8kg	*RCS302
RCS502	45t	60mm	122mm	10.0kg	*RCS502

* - SPECIAL ORDER: PLEASE QUOTE ITEM CODE UPON ORDERING THIS PRODUCT

HOLLOW PLUNGER HYDRAULIC CYLINDERS

ENERPAC

- Durable and corrosion resistant
- Hollow plunger design allows for both pull and push forces
- Suitable across all industries for lifting, lowering, pushing and pulling
- Max. pressure: 10,000psi (700bar)



Item Code	Capacity	Stroke	Centre Hole Dia.	Collapsed Height	Weight	Bishops Code
RCH121	12t	42mm	19.6mm	120mm	2.8kg	*RCH121
RCH123	13t	76mm	19.6mm	184mm	4.4kg	*RCH123
RCH202	20t	49mm	26.9mm	162mm	7.7kg	77080750
RCH206	20t	155mm	26.9mm	306mm	14.1kg	*RCH206
RCH302	30t	64mm	33.3mm	178mm	10.9kg	77080760
RCH306	30t	155mm	33.3mm	330mm	21.8kg	*RCH306
RCH603	60t	76mm	53.8mm	247mm	28.1kg	77075560
RCH606	60t	153mm	53.8mm	323mm	35.4kg	*RCH606
RCH1003	95t	76mm	79mm	254mm	63kg	*RCH1003

* - SPECIAL ORDER: PLEASE QUOTE ITEM CODE UPON ORDERING THIS PRODUCT

GET MORE AT BISHOPS



HYDRAULIC OILS

Page 441

PUMP UP YOUR HYDRAULIC KNOWLEDGE

Hydraulic equipment allows you to complete tasks previously impossible to do by hand. Could you imagine trying to lift 150 tonnes? That's almost the weight of your average house!

Hydraulic Cylinders are used for a range of lifting, lowering, pushing and pulling applications. These come in two different varieties; single acting and double acting.

Single Acting cylinders use the working fluid to either push or pull a load. The force of the load then allows the piston to return to its starting position.

Double Acting cylinders use working fluid on both sides of the piston in order to create a pushing and pulling force on the load. These cylinders work well in situations where either there is no external force to retract the piston or where a force is required in both directions.

Aluminium vs. Steel Hydraulic Cylinders

Hydraulic cylinders come in two main materials; aluminium and steel. Aluminium is a much lighter material which makes it great for transport. This material also provides high corrosion resistance making it great for varying weather conditions. Under constant, consistent use, aluminium will wear very quickly causing the system to fail. Steel is a much tougher material which is made to withstand constant and consistent use in applications such as manufacturing.

Specialty Styles – Hollow & Low Profile

Hydraulic cylinders can be made in two styles for specific purposes. Hollow cylinders feature a centre hole running through the jack which allows for chains and ropes to be fed through the middle to tug, pull and create tension. Low profile cylinders, as the name suggests, are short in height and designed for applications where there is only a low clearance.

SINGLE ACTING CYLINDER/PUMP SETS



- The quickest and easiest way to start working right away
- Optimum match of individual components
- Max. pressure: 10,000psi (700bar)

All Sets Include:

- A cylinder
- Two speed hand pump
- 1.8m safety hose
- Gauge
- Adaptor



SCR102H

Item Code	Capacity	Stroke	Collapsed Height	Cylinder
SCR55H	5t	127mm	215mm	RC-55
SCR102H	10t	54mm	121mm	RC-102
SCR106H	10t	156mm	247mm	RC-106
SCR1010H	10t	257mm	349mm	RC-1010
SCR252H	25t	50mm	165mm	RC-252
SCR254H	25t	102mm	215mm	RC-254
SCR256H	25t	158mm	273mm	RC-256
SCR2514H	25t	362mm	476mm	RC-2514
SCR506H	50t	159mm	282mm	RC-506
SCH1003H	95t	76mm	254mm	RCH-1003

SPECIAL ORDER: PLEASE QUOTE ITEM CODE UPON ORDERING THIS PRODUCT

HYDRAULIC HAND PUMPS



- Lightweight, compact durable design available in single and two speed pumps
- Two speed design for faster operation
- Integral 4-way valve on P842 for operation of double-acting cylinders
- Max. operating pressure: 10,000psi (700bar)



P392

Item Code	Oil Capacity	Pressure Rating – 1st	Weight
P142	0.327L	13bar	2.4kg
P392	0.901L	13bar	4.1kg
P802	2.54L	27bar	8.2kg
P842	2.54L	27bar	10kg

SPECIAL ORDER: PLEASE QUOTE ITEM CODE UPON ORDERING THIS PRODUCT

ULTIMA STEEL HYDRAULIC HAND PUMPS



- Durable and corrosion resistant steel
- Two speed design for fast operation
- Integral reservoir over-pressurisation protection
- Portable pump suitable for Enerpac tools and cylinders
- 4-way valving on the P-84 and P-464 for operation of double-acting cylinders
- Max. operating pressure: 10,000psi (700bar)



P39

Item Code	Description	Oil Capacity	Weight	Bishops Code
P39	Single Speed	0.77L	6.2kg	*P39
P77	Two Speed	0.77L	7.1kg	77075870
P80	Two Speed	2.2L	10.7kg	77075872
P84	Two Speed	2.2L	11.8kg	*P84
P462	Two Speed	7.423L	27.7kg	*P462
P464	Two Speed	7.423L	27.7kg	*P464

*** – SPECIAL ORDER: PLEASE QUOTE ITEM CODE UPON ORDERING THIS PRODUCT**

TURBO II AIR HYDRAULIC PUMPS



- Easily operated by hand or foot
- Reinforced heavy duty lightweight reservoir for applications in tough environments
- Oil Capacity: 2.1L



PATG1102N

Item Code	Valve	Weight
PATG1102N	Treadle 3/3	8.2kg
PAMG1402N	Manual 4/3	11kg

SPECIAL ORDER: PLEASE QUOTE ITEM CODE UPON ORDERING THIS PRODUCT



CORDLESS & ELECTRIC HYDRAULIC PUMPS

CORDLESS HYDRAULIC PUMPS

ENERPAC

- Durable cordless technology 28V
 - Manual valve
 - Trigger lock-off
 - Flow rate: 2L/min (no load), 0.25L/min (load)
 - Max. operating pressure: 10,000psi (700bar)
 - Oil capacity: 2L
 - Weight: 11kg
- Includes:**
- 2 x Batteries
 - 230V Charger



XC1202ME

Item Code	Pump Type	Valve Function	Bishops Code
XC1202ME	Single Acting	3-Way, 2-Position	77075876
XC1402ME	Double-Acting	4-Way, 3-Position	*XC1402ME

* - SPECIAL ORDER: PLEASE QUOTE ITEM CODE UPON ORDERING THIS PRODUCT

ECONOMY ELECTRIC HYDRAULIC PUMPS

ENERPAC

- Lightweight and compact design powering small to medium size cylinders and hydraulic tools
- 230 VAC 50/60-cycle universal motor will operate under poor voltage supply
- Max. operating pressure: 10,000psi (700bar)
- Oil capacity: 3.8L
- Other models available



PUJ1201E

Item Code	Valve Type	Valve Function	Weight	Bishops Code
PUJ1201E	3/2 Manual	Advance/Hold/Retract	15.4kg	77075878
PUD1301E	3/2 Solenoid	Dump & Hold	17.5kg	*PUD1301E

* - SPECIAL ORDER: PLEASE QUOTE ITEM CODE UPON ORDERING THIS PRODUCT

ZU-SERIES PORTABLE ELECTRIC HYDRAULIC PUMPS

ENERPAC

- High efficiency hydraulic pump design
- Powerful 1.25kW universal electric motor
- Designed for use in workshops and remote locations
- Several valve configurations available
- Max. operating pressure: 10,000psi (700bar)



ZU4304ME

Item Code	Description	Oil Capacity	Weight
ZU4304ME	Manual	4.6L	25kg
ZU4308JE	Remote (Manual)	6.8L	28kg
ZU4320SE	Remote (Solenoid)	20L	57kg

SPECIAL ORDER: PLEASE QUOTE ITEM CODE UPON ORDERING THIS PRODUCT

PRO-SERIES ELECTRIC TORQUE WRENCH PUMP

ENERPAC

- Two speed operation for fast cycle time
- Roll cage protects the pump and provides increased stability
- Pendant control from 6m
- Auto cycle feature for continuous operation
- Easy to use LCD screen
- Compatible with all mainstream torque wrenches and hoses
- Flow @ rated pressure: 1.0L/min
- Max. operating pressure: 10,000psi (700bar)
- Capacity: 8L



Item Code
ZU4208TA-QR

SPECIAL ORDER: PLEASE QUOTE ITEM CODE UPON ORDERING THIS PRODUCT

LAT-SERIES AIR HYDRAULIC TORQUE PUMP

ENERPAC

- Easy to lift and transport
- Can be moved without a crane, hoist or elevator
- Compatible with all mainstream torque wrenches and hoses
- Flow @ rated pressure: 0.4L/min
- Max. operating pressure: 10,000psi (700bar)
- Capacity: 1.9L
- Weight: 18kg

**Item Code**

LA2504TX-QR

SPECIAL ORDER: PLEASE QUOTE ITEM CODE UPON ORDERING THIS PRODUCT

GET MORE AT BISHOPS



WATER PUMPS

Page 326



SPANNERS

From Page 195

DSX-SERIES ALUMINIUM TORQUE WRENCHES

ENERPAC

- High strength, lightweight aluminium
- Slimline design for complete operator safety
- Fully enclosed drive for maximum safety
- Built-in tether connection for working at heights
- Retained quick-release button and reaction arm
- Fine tooth ratchet prevents tool 'locking on'
- 35° drive rotation
- Square drive



DSX11000

Item Code	Size	Max. Torque	Weight
DSX1500	3/4"	1,411ft/lbs (1,913Nm)	2.2kg
DSX3000	1"	3,233ft/lbs (4,383Nm)	4.8kg
DSX5000	1 1/2"	5,635ft/lbs (7,640Nm)	8.1kg
DSX11000	1 1/2"	11,000ft/lbs (14,914Nm)	14.4kg
DSX25000	2 1/2"	24,057ft/lbs (32,617Nm)	32.5kg

SPECIAL ORDER: PLEASE QUOTE ITEM CODE UPON ORDERING THIS PRODUCT

HMT-SERIES MODULAR TORQUE WRENCHES

- Hydraulic hex torque wrench drive
- Comes with ergonomic tool safety handle and link pin retainer as standard
- Interchangeable with many other manufacturers
- Solves bolting challenges quickly and safely
- Various attachment options
- Cassettes not included - must be ordered separately



HMT1500

Item Code	Max. Torque	Weight
HMT1500	1,541ft/lbs (2,089Nm)	1.0kg
HMT3500	3,750ft/lbs (5,084Nm)	1.8kg
HMT7500	7,562ft/lbs (10,252Nm)	3.2kg
HMT13000	13,489ft/lbs (18,289Nm)	9.7kg

*** - SPECIAL ORDER: PLEASE QUOTE ITEM CODE UPON ORDERING THIS PRODUCT**

W-SERIES HEXAGON HYDRAULIC TORQUE WRENCHES

- Durable, compact high strength steel design
- Safety handles keep hands clear of pinch points
- Low profile cassette provides low clearance access with a small nose radius
- Constant torque output provides high accuracy ($\pm 3\%$) across the full stroke
- 360° swivel manifold with screw lock couplers
- Cassettes not included - must be ordered separately



W15000PX

Item Code	Nominal Torque	Hex. Cassette Range	Weight
W2000PX	2,766Nm	30-60mm	1.4kg
W4000PX	5,661Nm	36-85mm	2.0kg
W8000PX	11,484Nm	50-105mm	3.0kg
W15000PX	20,785Nm	65-115mm	5.0kg
W22000PX	30,506Nm	75-135mm	7.7kg

*** - SPECIAL ORDER: PLEASE QUOTE ITEM CODE UPON ORDERING THIS PRODUCT**

S-SERIES SQUARE DRIVE HYDRAULIC TORQUE WRENCHES

- Durable, compact high strength steel design
- Safety handles keep hands clear of pinch points
- Constant torque output provides high accuracy ($\pm 3\%$) across the full stroke
- 360° swivel manifold with screw lock couplers



S11000PX

Item Code	Nominal Torque	Socket	Weight	Bishops Code
S1500PX	1,952Nm	19-50mm	3.2kg	*S1500PX
S3000PX	4,373Nm	19-100mm	5.6kg	77080985
S6000PX	8,338Nm	36-115mm	9.2kg	*S6000PX
S11000PX	15,151Nm	36-115mm	15.8kg	*S11000PX
S25000PX	35,455Nm	65-155mm	32.2kg	*S25000PX

*** - SPECIAL ORDER: PLEASE QUOTE ITEM CODE UPON ORDERING THIS PRODUCT**

ENERPAC

TWIN TORQUE WRENCH HOSES

- Thermoplastic dual torque wrench hoses
- Male x female ends
- Certified 4:1 safety factor
- Max. pressure: 10,000psi (700bar)



THQ712T

Item Code	Length	Bishops Code
THQ706T	6m	77080928
THQ712T	12m	*THQ712T

*** - SPECIAL ORDER: PLEASE QUOTE ITEM CODE UPON ORDERING THIS PRODUCT**

700-SERIES HIGH PRESSURE HYDRAULIC HOSES

- Polyurethane outside jacket to provide maximum abrasion resistance
- Low volumetric expansion under pressure to enhance overall system efficiency
- 4:1 safety factor
- Internal diameter: 6.4mm
- Connection 1: 3/8" NPTF
- Mine approved: HC7206-MDG41 and HC7210-MDG41
- Max. working pressure: 10,000psi (700bar)



HC7206



HC7206-MDG41

Item Code	Connection 2	Length	Bishops Code
HC7210	3/8" NPTF	3.0m	*HC7210
HC7220	3/8" NPTF	6.1m	*HC7220
HC7203	CH-604 Coupler	0.9m	*HC7203
HC7206	CH-604 Coupler	1.8m	*HC7206
HC7206-MDG41	CH-604 Coupler	1.8m	77080915
HC7210-MDG41	CH-604 Coupler	3m	77080920

*** - SPECIAL ORDER: PLEASE QUOTE ITEM CODE UPON ORDERING THIS PRODUCT**

HYDRAULIC COUPLERS & DUST CAPS

- Provides quick connection of hydraulic lines
- 3/8" couplers for cylinders, tools, and pumps
- Max. pressure: 10,000psi (700bar)

Dust Caps:

- Protects couplers and prevents contamination



CH604



CR400



CD411

Item Code	Description	Bishops Code
C604	High Flow Coupler Set	36810604
CH604	High Flow Male Coupler	36810602
CR400	High Flow Female Coupler	36810600
CD411	Rubber Dust Cap To Suit CR-400 & CH-604	*CD411

*** - SPECIAL ORDER: PLEASE QUOTE ITEM CODE UPON ORDERING THIS PRODUCT**



HYDRAULIC GAUGES & ADAPTORS & HOSE REELS

HYDRAULIC FORCE & PRESSURE GAUGES

- Glycerine filled
- Dual scale reading calibrated in bar and psi
- Gauge snubbers or needle valves recommended for high cycle applications

GA45GC:

- Positioned at a 45° angle to ensure the best possible readings to easily monitor your system's performance
- Can be used on a broad range of systems



GA45GC

ENERPAC



G4039L

Item Code	Connection	Cylinder	Working Pressure	Face Dia.	Bishops Code
GA45GC	3/8" NPTF	All Cylinders	0-700bar	63mm	77080930
G2535L	1/4" NPTF	All Cylinders	0-700bar	63mm	*G2535L
G4039L	1/2" NPTF	All Cylinders	0-700bar	100mm	*G4039L
GP10S	1/2" NPTF	All Cylinders	0-700bar (0-10,000psi)	100mm	77080940

* - SPECIAL ORDER: PLEASE QUOTE ITEM CODE UPON ORDERING THIS PRODUCT

GA-SERIES GAUGE ADAPTORS

- For easy mounting of a pressure gauge onto your system
- Male x female connection: 3/8" NPTF
- Max. operating pressure: 10,000psi (700bar)

ENERPAC



GA2

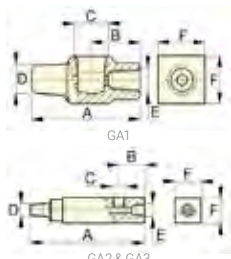

Item Code	Gauge Port	Dimensions					
		A	B	C	D	E	F
GA1	1/2"	71mm	31mm	1/2" NPTF	3/8" NPTF	3/8" NPTF	32mm
GA2	1/2"	155mm	35mm	1/2" NPTF	3/8" NPTF	3/8" NPTF	32mm
GA3	1/4"	133mm	35mm	1/4" NPTF	3/8" NPTF	3/8" NPTF	32mm

SPECIAL ORDER: PLEASE QUOTE ITEM CODE UPON ORDERING THIS PRODUCT

HYDRAULIC SAFETY

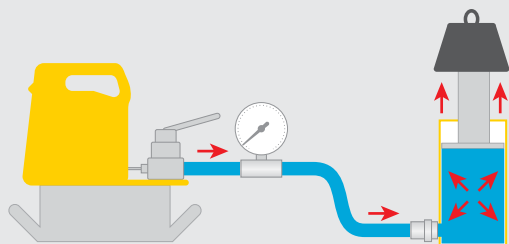

Remember, each hydraulic system is rated to a **maximum capacity**. Never exceed this value or you could risk the failure of the system.

Hydraulic systems also have pressure ratings. This rating provides a value for the **maximum amount of pressure** that the internal chambers can safely take. Do not exceed this value.

HOW TO UPGRADE YOUR HOSE SYSTEM

Make your upgrade process quick and easy with this selection guide.

Option 1

You can find a wide range of fit for purpose, pre-assembled hose reels in the following pages that we're confident will meet your needs. Can't find the one you need? Just give us a call.

Option 2

Your second option allows you to fully customise your set-up from your hose reel to your hose and fittings.

Step 1: Select a hose reel

Step 2: Select a hose

Step 3: Assemble with your desired fittings

Prefer option 2?

Jump to page 478 to start the three steps.

It's easy with Bishops!

R3 GARDEN WATER REEL

RETRACTA

- High quality horticultural hose
- UV stable, impact resistant case
- Wear resistant Pro-Glide™ mouth
- Premium German engineered main spring
- Retracta FLEX Hybrid Polymer hose material
- Green case
- Fully serviceable
- Hose size: 1/2" x 25m
- Inlet: Hose and tap connector
- Outlet: Hose connector with spray gun
- Max. pressure: 150psi
- Max. temperature: 60°C



Item Code

DR425G-03

SPECIAL ORDER: PLEASE QUOTE ITEM CODE UPON ORDERING THIS PRODUCT

RETRACTA R3 PREMIUM AIR HOSE REEL ASSEMBLIES

RETRACTA

- Compressed air hose assembly
- Rubberised reinforced PVC
- High quality premium air hose
- UV stable, impact resistant case
- Wear resistant Pro-Glide™ mouth
- Premium German engineered main spring
- Fully serviceable
- Pressure rating: 270psi
- Colour: Red
- Australian manufactured



AR320R-01

Item Code	Hose Size	Inlet	Outlet	Bishops Code
AR320R-01	3/8" x 20m	3/8" BSP	1/4" BSP	68540000
AR415R-01	1/2" x 15m	3/8" BSP	3/8" BSP	68540002

RETRACTA R3 GREASE REEL



- High quality grease hose
- UV stable, impact resistant case
- Wear resistant Pro-Glide™ mouth
- Wire reinforced rubber (SAE100R2) hose material
- Premium German engineered main spring
- Fully serviceable
- Hose size: 1/4" x 15m
- Inlet: 1/4" BSP (F)
- Outlet: 1/4" BSPT (M)
- Max. pressure: 5,000psi



Item Code	Bishops Code
GR215K-01	68540010

HEAVY DUTY HOSE REELS

- Impact resistant UV stabilised covers for maximum durability
- High flow swivel and fluid path for maximum air flow
- Automatic and positive latching mechanism
- Adjustable spring tension
- Crimped hose ends reduce OH&S concerns and possible air leaks
- Can be mounted on the floor, wall or ceiling
- Detachable steel mounting bracket enables 180° hose reel rotation



SA400N

Item Code	Application	Size	Bishops Code
SA300N	Air	10(ID)mm x 18(l)m	68540020
SA400N	Air	12(ID)mm x 15(l)m	68540040
SAW100	Air/Water	10(ID)mm x 16(l)m	68540042
SAW200	Air/Water	12(ID)mm x 13(l)m	*SAW200
SW500N	Air/Water	12(ID)mm x 18(l)m	68540080
SO600	Oxygen/Acetylene	6(ID)mm x 15(l)m	*SO600

* - SPECIAL ORDER: PLEASE QUOTE ITEM CODE UPON ORDERING THIS PRODUCT

ALEMITE HEAVY DUTY HOSE REELS



- Spring rewind hose reels
- Corrosion resistant, easy to install and incredibly durable
- Sealed spring cassette and plated bearings
- Easy and quick mounting
- Narrow width
- Lifetime warranty on the hose guide assembly and latch pawl spring



8080-A

Item Code	Application	Size	Bishops Code
8080-A	Grease	10(ID)mm x 25(l)m	*8080-A
8080-E	Oil	19(ID)mm x 15(l)m	*8080-E
8080-F	Air, Water, Oil	19(ID)mm x 25(l)m	*8080-F
8080-G	Air, Water, Oil	25(ID)mm x 15(l)m	68540046

* - SPECIAL ORDER: PLEASE QUOTE ITEM CODE UPON ORDERING THIS PRODUCT

EL SERIES HEAVY DUTY HOSE REELS

- Reinforced steel frame for maximum strength and stability
- Reliable spring life tested to 20,000 cycles and positive ratchet lock design ensures a long working life
- Durable long lasting powder coated finish
- Can be floor, wall or ceiling mounted
- Supplied with 1.2mm lead in hose
- 1.5mm thick robust drum assembly with stiffening ribs and flange edges
- 110° swivel base available on request



HR90005

Item Code	Application	Size
HR90005	Air, Water	1"(ID) x 30(l)m
HR90025	Air, Water	3/4"(ID) x 20(l)m
HR90010	Diesel	1"(ID) x 15(l)m

SPECIAL ORDER: PLEASE QUOTE ITEM CODE UPON ORDERING THIS PRODUCT

SAMOA HEAVY DUTY HOSE REELS

- Spring rewind hose reels
- Heavy duty full metal double pedestal construction
- Full port nickel protected steel shaft
- True full flow shaft and ports
- Large effective radial latching area for easy operation
- Fatigue resistant steel spring for longevity
- Epoxy coated for increased wear resistance
- Seven position outlet arm



504250

Item Code	Application	Size	Bishops Code
504250	Oil	12mm(ID) x 15(l)m	68540050
505224N	Air/Water/Oil/Fuel/Waste Oil	19mm(ID) x 15(l)m	68540090
508225	Water/Oil/Diesel Fuel/Waste Oil	25mm(ID) R1 x 15(l)m	*508225

* - SPECIAL ORDER: PLEASE QUOTE ITEM CODE UPON ORDERING THIS PRODUCT

OXY/ACETYLENE WELDING HOSE REEL

- Heavy duty steel construction with corrosion resistant powder coat finish
- Ideal for contractors, fabricators and people involved in the construction industry
- Suitable for use on utes, tray tops and flat bed trucks
- Supplied with 15m x 1/2" (ID) hose and 1.5m lead in hose
- Max. working pressure: 300psi



Item Code	Bishops Code
OS615	68540060

GET MORE AT BISHOPS



SAFETY GLOVES

From Page 2

RUBBER BOOTS

Page 82





HOW TO ASSEMBLE NEW HOSE ON A HOSE REEL

Using a hose reel to store your hose has many benefits including extending the life of your hoses. When it comes time to fit a new hose to a hose reel or replace an existing one, make sure you do it right.

Step 1:

Assemble and secure hose reel in line with manufacturer specifications to ensure that it's fit for purpose and will not affect the integrity of the hose.

Step 2:

Locate the coupling on the reel. If the reel is not supplied with one, take a look at Bishops' range in this section to find the right one for your needs. Connect the hose fitting to the coupling, ensuring a tight and secure seal.

Step 3:

Locate the leader hose and attach it to the source. Ensure a tight seal before connecting the other end of the leader hose to the reel and turning on the source.

Step 4:

Check all connections to ensure they are fitted correctly before proceeding to wind the reel using the built-in mechanism.

Need some additional help selecting the right fit for purpose hose, reel or fittings? Give your local Bishops branch a call.



STEP 1 – SELECT A REEL

Reels can be mounted to walls, ceilings and vehicles, or they can be used unmounted. Bishops has a range of hose reels that can fit your existing kit, from manual rewind and spring coil to anti-kink reels. Whatever your reel, Find it at Bshops.

Manual Rewind

Hand reels are manually controlled, operated by a rotating handle. They are an affordable entry to the hose market when you already have your own hose, coming in a variety of sizes to fit and connect to your existing hose.

Air & Spring Rewind

Air and spring rewind reels offer quick, reliable and neat hose retraction and storage. Pull and the hose unwinds to the desired length. With one small tug the hose retracts. This makes them a popular, easy and time-saving choice for everyday use.

MANUAL REWIND HOSE REELS

- Heavy duty manual hose reels
- Durable proprietary powder coating is corrosion resistant
- Low profile hose connector ensures smooth, even hose wraps
- Adjustable drag brake eliminates hose backlash when unreeling hose
- Full flow swivels facilitate high volume fluid transfer
- Rolled edges and barrel discs provide hose reel strength and operator safety
- Sturdy, all welded 'A' frame base provides exceptional strength



HR50020M

Item Code	Max. Pressure	Suits Hose
HR50010M	4,000psi	19(ID)mm x 30(l)m
HR50020M	4,000psi	12(ID)mm x 46(l)m

SPECIAL ORDER: PLEASE QUOTE ITEM CODE UPON ORDERING THIS PRODUCT

GET MORE AT BISHOPS

CAN'T FIND THE REEL YOU ARE AFTER?

Contact Bishops with your requirements.

bishopbro.com.pg
sales@bishopbro.com.pg

STEP 2 – SELECT A HOSE

With so many hoses to choose from, follow this simple selection guide to find the hose you need.

Hose Material

The first choice you have to make is which material is best suited for your needs. Hoses generally have two material specifications – the outer cover and the inner tube. Some hoses come with reinforcement helping to strengthen the hose and prevent the walls collapsing.

PVC is economical, versatile and often used for general purposes. PVC can be used to transfer a wide variety of substances, however is most commonly used for air, water and mild chemicals.

The bend radius of PVC hose is more restrictive than rubber hose, so consider this when making your selection.

Rubber is also used to transfer a wide variety of substances including high pressure air, water, fuel, oil and chemicals. Rubber hoses are flexible under all weather conditions and are often highly abrasion resistant.



Hose Application

Different variations in inner tube material and reinforcement allow some hoses to be used under high pressure, whilst others are suitable for suction and delivery.

Air/Water Hoses include your standard garden hoses and are often suited for general purpose use. Polyester reinforcement is common, allowing them to remain flexible.

Suction/Delivery Hoses are reinforced using a spiral formation often made of PVC or steel which allows the hose to compress and expand with minimal friction. These hoses are often very rigid and will not flex as much as other hoses.

Layflat Hoses are extremely flexible and durable. Their shape allows them to sit flat on the ground, reducing tripping hazards. Textile cord reinforcement gives them their flexible properties.

Chemical Hoses, such as those used for oil and fuel, are commonly made of nitrile rubber, which is highly resistant to heavy chemicals. These hoses have poor weather resistance and are only suitable for indoor use.



Material definitions:

- SBR:** Styrene-Butadiene Rubber
- EPDM:** Ethylene Propylene Diene Monomer
- NBR:** Acrylonitrile Butadiene Rubber (Nitrile)
- UHMW:** Ultra High Molecular Weight
- NR:** Natural Rubber

GENERAL PURPOSE PVC HOSE



- Suitable for general purpose and compressed air applications
- PVC inner tube and cover
- Reinforced with high tensile textile cords
- Oil mist, ozone and abrasion resistant
- Safety factor: 3:1
- Temperature range: -5°C to 60°C
- Transparent with red stripes
- FDA 90/128/EC
- Sold per metre



Internal Dia.	Outside Dia.	Max. Working Pressure	Weight	Bishops Code
6mm	11mm	300psi (20bar)	0.08kg/m	37004010
8mm	13mm	225psi (15bar)	0.095kg/m	37004020
10mm	15mm	225psi (15bar)	0.115kg/m	37004030
13mm	19mm	150psi (10bar)	0.165kg/m	37004040
19mm	25mm	150psi (10bar)	0.26kg/m	37004050
25mm	32mm	150psi (10bar)	0.39kg/m	37004060
38mm	48mm	100psi (7bar)	0.82kg/m	37004070

TYPE S COMPRESSED AIR/WATER PVC HOSE

- Suitable for general industrial and compressed air applications, as well as various crop spraying jobs
- Reinforced with high tensile textile cords
- Oil mist, ozone and abrasion resistant
- Black PVC inner tube with yellow and blue striped PVC cover
- Safety factor: 3.2:1
- Temperature range: -5°C to 60°C
- Exceeds AS/NZS 2554/B
- Sold per metre

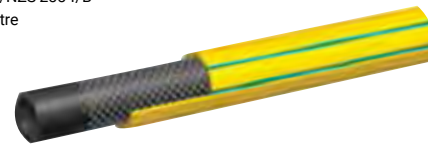

Internal Dia.	Outside Dia.	Max. Working Pressure	Min. Bend Radius	Bishops Code
6mm	12mm	300psi (20bar)	48mm	37006010
8mm	14mm	300psi (20bar)	64mm	37006020
10mm	16mm	300psi (20bar)	80mm	37006030
13mm	19mm	300psi (20bar)	104mm	37006040
19mm	27mm	300psi (20bar)	152mm	37006050
25mm	34mm	300psi (20bar)	200mm	37006060
38mm	50mm	240psi (16bar)	304mm	37006070
51mm	63mm	240psi (16bar)	408mm	37006080

GENERAL PURPOSE SUCTION & DELIVERY HOSE



- Suitable for liquid suction and delivery in general purpose applications
- Transparent PVC with steel helix wire reinforcement
- Abrasion and ozone resistant
- Safety factor: 3:1
- Temperature range: -5°C to 60°C
- FDA 90/128/EC AS2070
- Sold per metre



Internal Dia.	Outside Dia.	Min. Bend Radius	Vacuum	Max. WP	Weight	Bishops Code
25mm	33mm	150mm	90%	100psi (7bar)	0.52kg/m	37020215
32mm	40mm	128mm	85%	60psi (4bar)	0.66kg/m	37020220
38mm	48mm	152mm	80%	60psi (4bar)	0.86kg/m	37020230
51mm	61mm	204mm	80%	45psi (3bar)	1.23kg/m	37020240
63mm	75mm	252mm	80%	30psi (2bar)	1.78kg/m	37020250
76mm	90mm	304mm	70%	30psi (2bar)	2.45kg/m	37020260
102mm	116mm	408mm	70%	30psi (2bar)	3.48kg/m	37020270
150mm	172mm	608mm	70%	30psi (2bar)	7.3kg/m	37020290



PVC & RUBBER HOSES

PVC LAYFLAT WATER DELIVERY HOSE

- Standard duty hose for water delivery applications
- PVC inner tube and cover with high tensile textile cord reinforcement
- Safety factor: 3:1
- Temperature range: -10°C to 60°C
- Blue
- Sold per metre

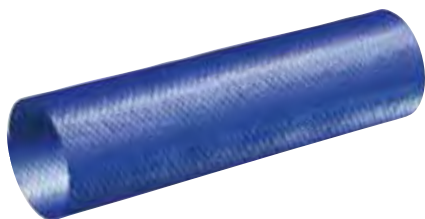

Internal Dia.	Outside Dia.	Weight	Bishops Code
51mm	75psi (5bar)	0.27kg/m	37018020
63mm	60psi (4bar)	0.38kg/m	37018030
76mm	60psi (4bar)	0.53kg/m	37018040
102mm	60psi (4bar)	0.71kg/m	37018050
152mm	45psi (3bar)	1.18kg/m	37018060

MULTIPURPOSE RUBBER HOSE

- Excellent resistance to ageing, atmospheric conditions and ozone
- Non-conductive outer cover
- Specific compound to resist petroleum products with aromatic content to 50%
- Economical general-purpose hose suitable for the safe transfer of air, water, oil and all alcohol blended fuels including leaded and unleaded
- Great all round hose to minimise stock holdings
- Black smooth NBR (Class A) inner tube
- Red smooth non-conductive NBR blend cover
- High tensile textile cord reinforcement
- Temperature range: -20°C to 95°C
- Max. working pressure: 300psi (20bar)
- Safety factor: 4:1 (5-38mm), 3:1 (51mm)
- Sold per metre



Item Code	Internal Dia.	Outside Dia.	Bishops Code
08-210-006-CUT	6.4mm	13mm	37008010
08-210-008-CUT	7.9mm	15mm	37008020
08-210-010-CUT	9.5mm	17mm	37008030
08-210-012-CUT	12.7mm	20mm	37008040
08-210-016-CUT	15.9mm	26mm	37008050
08-210-019-CUT	19.1mm	29mm	37008060
08-210-025-CUT	25.4mm	35.5mm	37008070
08-210-032-CUT	31.8mm	44mm	37008075
08-210-038-CUT	38.1mm	54mm	37008080
08-210-051-CUT	50.8mm	67mm	37008090

AIR & WATER RUBBER DELIVERY HOSE

- A sturdy water delivery hose for use in all sectors of industry, including agriculture, mining, general industry and aquaculture
- Good cold weather flexibility
- Outer cover offers good resistance to abrasion and atmospheric conditions
- Black NR/SBR inner tube and cover
- High tensile cord reinforcement
- Temperature range: -25°C to 85°C
- Max. working pressure: 145psi (10bar)
- 20m roll

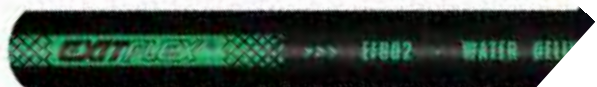

Item Code	Internal Dia.	Outside Dia.	Bishops Code
10-100-019-020	19mm	29mm	37012020
10-100-051-020	51mm	62mm	37012050
10-100-063-020	63mm	78mm	37012055
10-100-102-020	102mm	115mm	37012070

COMPRESSED AIR RUBBER MINING HOSE



- Designed for pneumatic machines and tools, such as rock drills and air/water mining applications
- Good cold weather flexibility
- Good resistance to fatigue, bending and twisting
- Excellent resistance to abrasion and atmospheric conditions
- Black NR/SBR blend inner tube and cover
- High tensile braid reinforcement
- Temperature range: -20°C to 80°C
- Max. working pressure: 300psi (20bar)
- Safety factor: 3:1
- Standards: AS2554 Type B
- Sold per metre



Item Code	Internal Dia.	Outside Dia.	Bishops Code
10-000-012-020	13mm	23mm	37012210
10-000-019-020	19mm	31mm	37012220
10-000-025-020	25mm	37mm	37012230
10-000-051-020	51mm	65mm	37012240
10-000-076-020	76mm	92mm	37012250

STRAIGHT RADIATOR HOSE

- Black EPDM tube reinforced with high tensile textile cords
- Heat, abrasion and ozone resistant
- Safety factor: 3:1
- Temperature range: -40°C to 120°C
- Max. working pressure: 75psi (5bar)
- Length: 900mm
- Exceeds DIN 73411 and SAE 20R1 D-2



Internal Dia.	Outside Dia.	Bishops Code	Internal Dia.	Outside Dia.	Bishops Code
19mm	27mm	37044030	51mm	61mm	37044100
25mm	33mm	37044050	57mm	67mm	37044105
32mm	40mm	37044060	63mm	73mm	37044110
38mm	48mm	37044070	76mm	86mm	37044140
40mm	50mm	37044080	90mm	102mm	37044160
45mm	55mm	37044090	102mm	114mm	37044170

FUEL & EMISSION HOSE



- Multipurpose fuel line hose for use with diesel, oil, leaded and unleaded petrols, ethanol, methanol and others
- Excellent resistance to petroleum derivatives, ozone and heat
- Kink resistant
- Available in longer lengths
- High tensile textile braid reinforcement
- Smooth black nitrile inner tube and cover
- Temperature range: -20°C to 70°C
- Safety factor: 3:1
- Sold per metre



Item Code	Diameter	Bishops Code
08-401-005-CUT	5mm	37026030
654AA006	6mm	37026040
08-401-006-CUT	6.5mm	37026050
08-401-008-CUT	8mm	37026060
08-401-010-152	10mm	37026070
08-401-012-CUT	12.5mm	37026080

FUEL/OIL SUCTION & DELIVERY HOSE

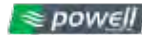

- Suitable for the safe transfer of virtually all petroleum based products
- Ideally suited for use as transfer lines for diesel, ethanol, gasolines, oil and petroleum based products with an aromatic content of up to 50%
- Excellent resistance to ageing, atmospheric conditions and ozone
- Black smooth NBR inner tube
- Black wrapped NBR (FRAS) cover
- High tensile textile cord with steel wire helix reinforcement
- Temperature range: -20°C to 80°C
- Safety factor: 3:1
- Working pressure at 20°C: 150psi (10bar)
- Standards: Meets/exceeds SAE100 R4
- Sold per metre



Item Code	Internal Dia.	Outside Dia.	Min. Bend Radius	Vacuum	Weight	Bishops Code
10-500-019-020	19mm	29mm	76mm	100%	0.61kg/m	37022010
10-500-025-020	25mm	35mm	100mm	100%	0.76kg/m	37022020
10-500-032-020	32mm	42mm	128mm	100%	0.9kg/m	37022030
10-500-038-020	38mm	48mm	152mm	100%	1.05kg/m	37022040
10-500-051-020	51mm	61mm	204mm	100%	1.35kg/m	37022060
10-500-063-020	63mm	75mm	252mm	90%	2.11kg/m	37022070
10-500-076-020	76mm	88mm	304mm	90%	2.52kg/m	37022080
10-500-102-020	102mm	116mm	408mm	90%	3.5kg/m	37022090
10-510-152-CUT	152mm	170mm	608mm	80%	7.36kg/m	37022100

SELF-STORE HOSE

- Nylon
- Fittings sold separately
- Yellow available on request

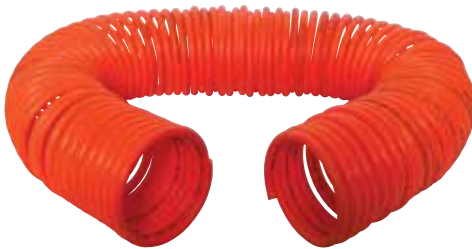

Working Pressure	ID x Maximum Extension	Bishops Code
1,241kPa (180psi)	¼" x 15m	73686125
1,241kPa (180psi)	¾" x 26m	73686250
1,034kPa (150psi)	½" x 23m	73686350

SELF-STORE HOSE FITTINGS

- Swivel and non-swivel hose fittings and nylon olives



73686710

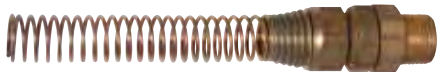

73686620

Description	Size	Bishops Code
Non-Swivel	½" ID x ½" BSP	73686710
Swivel	¼" ID x ¼" BSP	73686520
Swivel	¾" ID x ¾" BSP	73686620
Swivel	½" ID x ½" BSP	73686720

FLEXIBLE NYLON TUBE

- Metric
- Medium pressure type
- Corrosion and chemical resistant
- Min. burst pressure: 1,160psi
- Max. working pressure: 290psi
- Black



Outside Dia.	Bishops Code	Outside Dia.	Bishops Code
4mm	38490050	8mm	38490080
5mm	38490060	10mm	38490090
6mm	38490070	12mm	38490100

FLEXIBLE NYLON TUBE

- Imperial
- Medium pressure type
- Corrosion and chemical resistant
- Min. burst pressure: 1,000psi
- Max. working pressure: 250psi
- Black



Outside Dia.	Bishops Code	Outside Dia.	Bishops Code
⅛"	38490010	⅜"	38490030
⅜"	38490015	½"	38490040
¼"	38490020	⅝"	38490045
⅝"	38490025	-	-

POLYETHYLENE TUBE

- Temperature range: -20°C to 60°C
- Max. working pressure: 115psi
- Black



Outside Dia.	Bishops Code	Outside Dia.	Bishops Code
4mm	38690040	10mm	38690100
6mm	38690060	12mm	38690120
8mm	38690080	-	-

GET MORE AT BISHOPS



TUBE CUTTERS

From Page 210



HOSE ASSEMBLIES

CHOOSE YOUR FIT FOR PURPOSE HOSE & HOSE ASSEMBLY

No matter what fluid you deal with or what you're cleaning, Bishops has a great range of hose and hose assemblies from some of the toughest and most trusted brands. Each hose type is designed for a particular purpose with its own advantages, so it's essential that you use a fit-for-purpose hose and housing to achieve the greatest results.

Water

Explore our large range of water suitable hoses that can handle hot and cold water in a range of lengths. If you're moving your hose around the worksite, go for a lightweight plastic assembly with a handle. Most general water hose assemblies come with a spray nozzle or trigger gun.

Compressed Air/Water

Need a little more versatility in your equipment? Pick up an assembly that can handle either compressed air or water.

Oil

Typically made from nitrile rubber, PVC or styrene rubber, oil hoses are suitable for the transport of oil based products. Often coupled with a heavy duty metal reel to increase stability and reduce vibration when fitted to service vehicles.

Oxy Acetylene & Oxy LPG

Each hose is colour coded (blue for oxygen, red for acetylene, orange for LPG) for quick and easy identification. Reels are typically made of tough steel inclusive of a corrosion resistant powder coat finish ideal for general welding applications.

Weedicide/Pesticide

These hoses are UV stabilised and made from reinforced PVC with high chemical resistance. Corrosion and weather resistant construction make their reels ideal for outdoor use.

Heavy Duty Assemblies

A heavy duty assembly is needed when dealing with corrosive materials, on mining or construction sites, in workshops or wherever durability is important. Where hoses will encounter rubbing or abrasive surfaces it's best to choose abrasion-resistant hoses for longer life.

The range at Bishops includes hoses and tough, durable housings and mounts to ensure maximum durability and performance at any worksite.

It's easy with Bishops!

PVC AIR/WATER HOSE ASSEMBLY

- Assembled with Type S Nitto fittings
- Suitable for general industrial and compressed air applications, as well as various crop spraying jobs
- Black PVC inner tube with ribbed PVC cover
- High tensile textile cord reinforcement
- Safety factor: 3.2:1
- Temperature range: -5°C to 60°C
- Hose: 10(ID) x 16(OD)mm
- Max. working pressure: 300psi (20bar)
- Min. bend radius: 80mm
- Weight: 0.17kg/m
- 20m roll
- Exceeds AS/NZS 2554/B



Bishops Code

37006090

COMPRESSED AIR RUBBER MINING HOSE ASSEMBLY



- Designed for pneumatic machines and tools, such as rock drills and air/water mining applications
- Good cold weather flexibility
- Good resistance to fatigue, bending and twisting
- Excellent resistance to abrasion and atmospheric conditions
- High tensile braid reinforcement
- Black NR/SBR blend inner tube
- Black NR/SBR blend cover
- Temperature range: -20°C to 80°C
- Max. working pressure: 300psi (20bar)
- Safety factor: 3:1
- Standards: AS2554 Type B
- 1" Type A claw coupling ends
- Length: 20m



Item Code	Internal Diameter	Bishops Code
10-000-09025-020ACP	25mm	86420310
10-000-9019-020ACP	20mm	86420308
17-175-10-000-038-AS	38mm	86420315
10-000-9051-020SCP	50mm	86420320

RUBBER HOSE ASSEMBLY



- High pressure compressed air service line hose
- For stationary or mobile compressors operating pneumatic tools in quarries, mining civil and road construction
- Very flexible at low temperatures
- Highly visible safety yellow outer cover
- Good resistance to abrasion and atmospheric conditions
- Comes with 3/4" Type A claw clamps
- Black SBR blend inner tube
- Yellow EPDM/SBR blend cover
- High tensile textile cord reinforcement
- Temperature: -20°C to 70°C
- Working pressure: 300psi (20bar)
- 19mm(ID) x 20m roll



Item Code	Bishops Code
08-000-9019-020AS	37012920

FUEL TRANSFER HOSE ASSEMBLIES



- Standard duty hose for fuel and oil suction and delivery
- Assembled with female camlocks, crimped and tested
- Internal wire in galvanised steel inner tube with PVC coated fabric cover
- Reinforced with superposed polypropylene films and sheets
- Hydrocarbon resistant
- Safety factor: 4:1
- Working pressure: 150psi (10 bar)
- Temperature range: -30°C to 100°C
- Vacuum: 90%
- Green body with yellow stripe

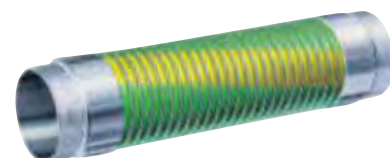

Item Code	Internal Dia.	Outside Dia.	Length	Min. Bend Radius	Weight	Bishops Code
16-100-9051-05CCE	50mm	66mm	5m	275mm	1.61kg/m	37028355
17-170-16-100-051-03	50mm	66mm	3m	90mm	1.6kg/m	37028354
17-170-16-100-051-10	50mm	66mm	10m	90mm	1.6kg/m	37028360
17-170-16-100-063-03	63mm	75mm	3m	100mm	2.4kg/m	37028348
17-170-16-100-063-06	63mm	75mm	6m	100mm	2.4kg/m	37028350
17-170-16-100-063-18	63mm	75mm	18.3m	100mm	2.4kg/m	37028353
17-170-16-100-076-01	75mm	88mm	1m	125mm	2.8kg/m	37028300
17-170-16-100-076-03	75mm	88mm	3m	125mm	2.8kg/m	37028330
17-170-16-100-076-05	75mm	88mm	5m	125mm	2.8kg/m	37028333
17-170-16-100-076-06	75mm	88mm	6m	125mm	2.8kg/m	37028338
17-170-16-100-076-10	75mm	88mm	10m	125mm	2.8kg/m	37028340
17-170-16-100-076-18	75mm	88mm	18.3m	125mm	2.8kg/m	37028343
17-170-16-100-102-08	100mm	112mm	8m	200mm	4.1kg/m	37028375
17-170-16-100-102-10	100mm	112mm	10m	200mm	4.1kg/m	37028380
17-170-16-100-102-18	100mm	112mm	18.3m	200mm	4.1kg/m	37028385

A TYPE MALE BSP CLAW COUPLINGS

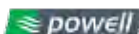

- Universal hose coupling that provides quick, safe and reliable connection for air and water hoses
- Common applications include underground and surface mining, mineral processing, compressor and air tool industries
- SG iron construction to ISO 1083, zinc plated, natural rubber seal (other materials on request)



Item Code	Size	Bishops Code
21-001-006	3/8"	37806530
21-001-008	1/2"	37804040
21-001-012	3/4"	37804050
21-001-016	1"	37804060
21-001-020	1 1/4"	37804061

A TYPE FEMALE BSP CLAW COUPLINGS

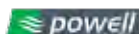

- Universal hose coupling that provides quick, safe and reliable connection for air and water hoses
- Common applications include underground and surface mining, mineral processing, compressor and air tool industries
- SG iron construction to ISO 1083, zinc plated, natural rubber seal (other materials on request)



Item Code	Size	Bishops Code
21-002-006	3/8"	37802057
21-002-008	1/2"	37806040
21-002-012	3/4"	37806050
21-002-016	1"	37806060

A TYPE HOSE TAIL CLAW COUPLINGS



- Universal hose coupling that provides quick, safe and reliable connection for air and water hoses
- Common applications include underground and surface mining, mineral processing, compressor and air tool industries
- SG iron construction to ISO 1083, zinc plated, natural rubber seal (other materials on request)



Item Code	Size	Bishops Code
21-000-006	3/8"	37802038
21-000-008	1/2"	37802040
21-000-012	3/4"	37802050
21-000-016	1"	37802060
21-000-020	1 1/4"	37802058

RUBBER SEAL GASKET

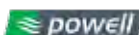

- NBR rubber construction
- To suit type A claw coupling 3/8"-1 1/4"



Item Code	Bishops Code
21-005-000	37812100

S TYPE MALE BSP CLAW COUPLINGS

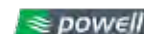

- Universal hose coupling that provides quick, safe and reliable connection for air and water hoses
- Common applications include underground and surface mining, mineral processing, compressor and air tool industries
- SG iron ISO 1083, zinc plated to AS 1789:2003, composite bellows seal (other materials on request)



Item Code	Size	Bishops Code	Item Code	Size	Bishops Code
21-101-008	1/2"	37806760	21-101-024	1 1/2"	37806784
21-101-012	3/4"	37806770	21-101-032	2"	37804080
21-101-016	1"	37806780	21-101-048	3"	37804082
21-101-020	1 1/4"	37806782	-	-	-

S TYPE FEMALE BSP CLAW COUPLINGS



- Universal hose coupling that provides quick, safe and reliable connection for air and water hoses
- Common applications include underground and surface mining, mineral processing, compressor and air tool industries
- SG iron ISO 1083, zinc plated to AS 1789:2003, composite bellows seal (other materials on request)



Item Code	Size	Bishops Code	Item Code	Size	Bishops Code
21-102-008	1/2"	37806730	21-102-024	1 1/2"	37806078
21-102-012	3/4"	37806740	21-102-032	2"	37806080
21-102-016	1"	37806750	21-102-048	3"	37806082

S TYPE HOSE TAIL CLAW COUPLINGS

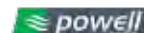

- Universal hose coupling that provides quick, safe and reliable connection for air and water hoses
- Common applications include underground and surface mining, mineral processing, compressor and air tool industries
- Machined seal cavity in coupling to ensure secure sealing under high pressures
- Zinc plated carbon steel
- Temperature range: -29°C to 71°C (Natural Rubber Seal)
- Working pressure: 500psi
- Safety factor: 3:1



Item Code	Size	Bishops Code	Item Code	Size	Bishops Code
21-100-008	1/2"	37806700	21-100-024	1 1/2"	37802070
21-100-012	3/4"	37806710	21-100-032	2"	37802080
21-100-016	1"	37806720	21-100-048	3"	37802082
21-100-020	1 1/4"	37802068	-	-	-

SAFETY LOCKING PINS



- Necessary to ensure claw couplings will not become disconnected
- 3/8"-3"
- 1,000 per box



Item Code	Bishops Code
21-008-000B	37850100



HOSE CLAMPS, WHIPCHECKS & CAMLOCK FITTINGS

DOUBLE BOLT CLAMPS

- SG Iron ISA 108
- Zinc plated



Item Code	Size	Bishops Code
44-022-029	1/2"	37840050
44-022-034	3/4"	37840060
44-022-039	1"	37840070

WHIPCHECKS

- Hose to hose, eliminates injury caused by broken air hose connections, highly resistant to rust and corrosion, no tools needed – easy to install and remove
- Crimped steel ferrules suitable for use in underground mines
- G1570 FC galvanised steel wire rope
- Mild steel ferrules
- Zinc plated steel spring
- Max working pressure: 200psi for air



Item Code	Size	Bishops Code
21-450-020	Small – Suits 3/8"-1 1/4" Hose	37215010
21-450-032	Medium – Suits 1 1/4"-2" Hose	37215020
21-450-064	Large – Suits 2 1/2"-4" Hose	37215030

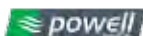

TYPE A ALUMINIUM CAMLOCK ADAPTORS

- MIL C - 27.487
- Adaptor to female BSP
- Aluminium construction



Item Code	Size (BSP)	Bishops Code	Item Code	Size (BSP)	Bishops Code
20-000-A100	1"	37602010	20-000-A400	4"	37602040
20-000-A150	1 1/2"	37602015	20-000-A600	6"	37602060
20-000-A200	2"	37602020	20-000-A200300	2" x 3"	37625030
20-000-A250	2 1/2"	37602025	20-100-A300200	3" x 2"	37625070
20-000-A300	3"	37602030	-	-	-



TYPE B ALUMINIUM CAMLOCK COUPLINGS

- MIL C - 27.487
- Coupler to male BSPT



Item Code	Size (BSPT)	Bishops Code	Item Code	Size (BSPT)	Bishops Code
20-000-B075	3/4"	37604007	20-000-B250	2 1/2"	37604025
20-000-B100	1"	37604010	20-000-B300	3"	37604030
20-000-B150	1 1/2"	37604015	20-000-B400	4"	37604040
20-000-B200	2"	37604020	20-000-B300200	3" x 2"	37625040



GET MORE AT BISHOPS



SAFETY GLASSES

Page 13

CABLE TIES

Page 366



CUTTING PLIERS

Page 207

TYPE C ALUMINIUM CAMLOCK COUPLINGS

- MIL C - 27.487
- Coupler to hose shank



Item Code	Internal Dia.	Bishops Code	Item Code	Internal Dia.	Bishops Code
20-000-C100	1"	37606010	20-000-C250	2 1/2"	37606025
20-000-C125	1 1/4"	37606012	20-000-C300	3"	37606030
20-000-C150	1 1/2"	37606015	20-000-C400	4"	37606040
20-000-C200	2"	37606020	20-000-C600	6"	37606060



TYPE D ALUMINIUM CAMLOCK COUPLINGS

- MIL C - 27.487
- Coupler to female BSP



Item Code	Size (BSP)	Bishops Code	Item Code	Size (BSP)	Bishops Code
20-000-D100	1"	37608010	20-000-D300	3"	37608030
20-000-D150	1 1/2"	37608015	20-000-D400	4"	37608040
20-000-D200	2"	37608020	20-000-D600	6"	37608060
20-000-D250	2 1/2"	37608025	-	-	-



TYPE E ALUMINIUM CAMLOCK ADAPTORS



- MIL C - 27.487
- Adaptor to hose tail
- Aluminium construction



Item Code	Size (I.D.)	Bishops Code	Item Code	Size (I.D.)	Bishops Code
20-000-E100	1"	37610010	20-000-E300	3"	37610030
20-000-E125	1¼"	37610012	20-000-E400	4"	37610040
20-000-E150	1½"	37610015	20-000-E600	6"	37610060
20-000-E200	2"	37610020	20-000-E300200	3" x 2"	37625060
20-000-E250	2½"	37610025	-	-	-

TYPE F ALUMINIUM CAMLOCK ADAPTORS



- MIL C - 27.487
- Adaptor to male BSPT



Item Code	Size (BSPT)	Bishops Code	Item Code	Size (BSPT)	Bishops Code
20-000-F100	1"	37612010	20-000-F300	3"	37612030
20-000-F125	1¼"	37612012	20-000-F400	4"	37612040
20-000-F150	1½"	37612015	20-100-F200300	2" x 3"	37625100
20-000-F200	2"	37612020	20-000-F300200	3" x 2"	37625110
20-000-F250	2½"	37612025	-	-	-

CAMLOCK JOINERS



- Male x male



Item Code	Size	Bishops Code
20-000-AA150150	1½" x 1½"	37613115
20-000-AA200200	2" x 2"	37613120
20-000-AA300300	3" x 3"	37613130
20-000-AA400400	4" x 4"	37613140
20-000-AA300200	3" x 2"	37625150
20-000-AA400200	4" x 2"	37625035

TYPE DA ALUMINIUM CAMLOCK COUPLER X ADAPTORS

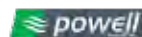

- Female x male



Item Code	Size	Bishops Code
20-000-CA200300	2" x 3"	37625180
20-000-CA300200	3" x 2"	37625190

TYPE DP ALUMINIUM CAMLOCK DUST PLUGS

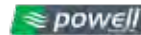

- MIL C - 27.487
- Male dust plug to suit couplers
- Not to be used in pressure situations



Item Code	Head Nominal Dia.	Bishops Code	Item Code	Head Nominal Dia.	Bishops Code
20-000-DP100	1"	37616010	20-000-DP300	3"	37616030
20-000-DP150	1½"	37616015	20-000-DP400	4"	37616040
20-000-DP200	2"	37616020	20-000-DP600	6"	37616060
20-000-DP250	2½"	37616025	-	-	-

TYPE DC ALUMINIUM CAMLOCK DUST CAPS

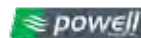

- MIL C - 27.487
- Female dust cap to suit adaptors
- Not to be used in pressure situations



Item Code	Head Nominal Dia.	Bishops Code	Item Code	Head Nominal Dia.	Bishops Code
20-000-DC100	1"	37618010	20-000-DC300	3"	37618030
20-000-DC150	1½"	37618015	20-000-DC400	4"	37618040
20-000-DC200	2"	37618020	20-000-DC600	6"	37618060
20-000-DC250	2½"	37618025	-	-	-

LOCKABLE ALUMINIUM CAMLOCK DUST CAPS



- Lockable cap protects hose from dust and contaminants
- Can be secured with a padlock
- Not to be used in pressure situations



Item Code	Head Nominal Dia.	Bishops Code
20-000-DCL200	2"	37618120
20-000-DCL300	3"	37618130
20-000-DCL400	4"	37618140

CAMLOCK RUBBER BUNA SEAL RING



- Buna/NBR rubber



Item Code	Diameter	Bishops Code	Item Code	Diameter	Bishops Code
20-900-100	1"	37690010	20-900-300	3"	37690050
20-900-150	1½"	37690020	20-900-400	4"	37690060
20-900-200	2"	37690030	20-900-600	6"	37690070
20-900-250	2½"	37690040	-	-	-



HOSE CLAMPS

SINGLE BOLT SUPER HOSE CLAMPS

- Mild steel
- Zinc plated

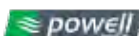

Item Code	Size Range	Bishops Code	Item Code	Size Range	Bishops Code
42-101-019	17-19mm	37206030	42-101-091	86-91mm	37206200
42-101-022	20-22mm	37206040	42-101-097	92-97mm	37206210
42-101-025	23-25mm	37206050	42-101-103	98-103mm	37206220
42-101-028	26-28mm	37206060	42-101-112	104-112mm	37206230
42-101-031	29-31mm	37206070	42-101-121	113-121mm	37206240
42-101-035	32-35mm	37206080	42-101-130	122-130mm	37206250
42-101-039	36-39mm	37206090	42-101-139	131-139mm	37206260
42-101-043	40-43mm	37206100	42-101-148	140-148mm	37206270
42-101-047	44-47mm	37206110	42-101-161	149-161mm	37206280
42-101-051	48-51mm	37206120	42-101-174	162-174mm	37206290
42-101-055	52-55mm	37206130	42-101-187	175-187mm	37206300
42-101-059	56-59mm	37206140	42-101-200	188-200mm	37206310
42-101-063	60-63mm	37206150	42-101-213	201-213mm	37206320
42-101-067	64-67mm	37206160	42-101-226	217-226mm	37206330
42-101-073	68-73mm	37206170	42-101-239	227-239mm	37206340
42-101-079	74-79mm	37206180	42-101-252	240-252mm	37206350
42-101-085	80-85mm	37206190	-	-	-

STAINLESS STEEL ECONOMY HOSE CLAMPS



Width	Size Range	Bishops Code	Width	Size Range	Bishops Code
10mm	8-12mm	37202007	50mm	50-70mm	37202060
12mm	10-16mm	37202010	60mm	60-80mm	37202070
16mm	11-20mm	37202015	82mm	72-95mm	37202090
20mm	14-27mm	37202020	90mm	78-101mm	37202100
25mm	18-32mm	37202030	100mm	100-120mm	37202110
38mm	21-44mm	37202050	125mm	120-140mm	37202130
45mm	32-50mm	37202055	140mm	130-152mm	37202140

26 PIECE HOSE CLAMP GRAB KIT

- Comes in hard plastic case for handy storage
- Includes:**
- Sizes: 16, 22, 25, 28, 35 and 40mm



Item Code	Bishops Code
FD-6080	40420070

STAINLESS STEEL MULTI-PURPOSE HOSE CLAMPS

- All stainless steel, solid band
- For industrial, hardware, automotive and general purpose use
- Heavy duty, non-perforated band
- Removable safety collar to prevent screwdriver slip injuries
- Rolled edge and smooth underside to prevent hose damage
- Technically advanced design improves sealing capability
- Made in Australia
- 10 per pack



Item Code	Size Range	Bishops Code
MICRO CLAMPS		
SMPC000P	9.5-12mm	37204010
SMPCM00P	11-16mm	37204020
SMPC00P	13-20mm	37204030
REGULAR CLAMPS		
SMPC0P	16-27mm	37204035
SMPC1P	22-38mm	37204040
SMPC1XP	30-42mm	37204050
SMPC2P	35-53mm	37204060
SMPC2XP	40-57mm	37204070
SMPC3P	52-70mm	37204080
SMPC4P	65-90mm	37204090
SMPC5P	85-110mm	37204100
SMPC6P	105-130mm	37204110
SMPC7P	130-155mm	37204120
SMPC9	180-205mm	37204130
SMPC10	205-230mm	37204140
SMPC11	230-255mm	37204150
SMPC13	280-305mm	37204180

150 PIECE HOSE CLAMP SET

- Designed to suit a variety of applications using handy storage cases with clamps
 - Ideal for farm, workshop or mobile use
- Includes:**
- 30 x Micro Clamps
 - 30 x EFI Clamps
 - 90 x Regular Clamps



Item Code	Bishops Code
CWP150	37204261

125 PIECE HOSE CLAMP SET

- MP Series hose clamps
 - Solid band with safety collar
 - A mix of micro and regular hose clamps
- Includes:**
- 40 x Micro clamps
 - 85 x Regular clamps



Item Code	Bishops Code
MP125	37204250

STAINLESS STEEL BAND

- 304 Stainless steel
- Thickness: 0.76mm
- 30m roll

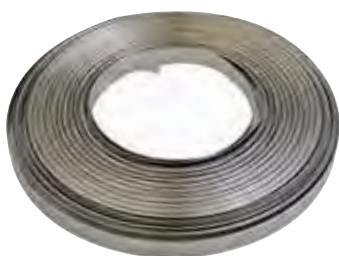

Item Code	Width	Bishops Code
46-000-203	10mm	37208010
46-000-204	12.7mm	37208020
46-000-205	16mm	37208030
46-000-206	19mm	37208040

CLAMP-IT BUCKLES

- Stainless steel banding strap buckles
- Economical method of securing banding
- To be used in conjunction with appropriate clamping tool



Item Code	Size	Quantity	Bishops Code
46-000-253	3/8"	100	37208050
46-000-254	1/2"	100	37208060
46-000-255	5/8"	100	37208070
46-000-256	3/4"	50	37208080

SOFT ANNEALED COPPER TUBING

- Refrigeration quality
- Wall thickness: 0.91mm
- Wall gauge: 20



Size	Bishops Code
3/16" x 30m	38590187
1/8" x 30m	38590125
1/4" x 30m	38590250
3/8" x 18m	38590375
1/2" x 18m	38590500

SELECTING THE RIGHT MATERIALS



When choosing a fitting, does it even matter what material it's made of? Yes!

Even if the fittings are the same size across different materials, it's still important to match the fitting material to the pipe material. Here are the two main reasons.

Hardness

Different materials have different levels of hardness based on their individual atomic bonds. Because of this, using a fitting or pipe of a softer material on a pipe fitting or pipe of hard material, will stop the ferrule from biting, causing a loss in pressure and increasing the possibility of a burst pipe.

Stainless steel is a relatively hard material, and therefore is best suited for use with stainless steel tubing. Brass is a much softer material and is best suited for use with copper tubing.

Corrosion

Common causes of corrosion can include bacteria, selective leaching, erosion and low pH liquids. When a joint has corroded, it can become very difficult, if not impossible to pull apart by hand and may call for the use of rough chemicals to treat it. Corrosion can also pollute the substance being transferred by the pipes.

Corrosion also commonly occurs when dissimilar metals are used together. For example, using galvanized steel pipe together with copper pipe will lead to galvanic corrosion.

This occurs when dissimilar metals with a connecting current flow (via liquid such as water) are paired. Use the table below to see the anodic and cathodic relationship between common metals. Always plan accordingly when assembling your system.

ANODIC (Least Noble)

- Magnesium
- Zinc
- Aluminium
- Carbon Steel or Cast Iron
- Copper alloys (Brass, Bronze)
- Lead
- Stainless Steel
- Nickel Alloys (Incoloy 825, Hastelloy B)
- Titanium
- Graphite

CATHODIC (Most Noble)



GET MORE AT BISHOPS



PIPE BENDERS

Page 333



HYDRAULIC HOSE FITTINGS & ADAPTORS

Bishops has a wide range of Hydraulic Hose Fittings & Adaptors to suit all your needs. We have the following fittings and more available at our warehouses across Papua New Guinea. Contact your local warehouse for more information or to place an order.

Hose Fittings

BSP



BSP Female Straight



BSPT Male Straight



BSP Female 45° Close



BSP Female 90° Close

JIC



Female Straight



Female Straight x Hex Collar



Female 90° Bend

SAE O-Ring Flange Code 61



Straight



45° Bend



90° Bend

SAE O-Ring Flange Code 62



Straight



45° Bend



90° Bend

NPT



Male Straight

UNO Ring



Male Straight

Hose Joiner



Double Ended Straight

Adaptors

Nipples

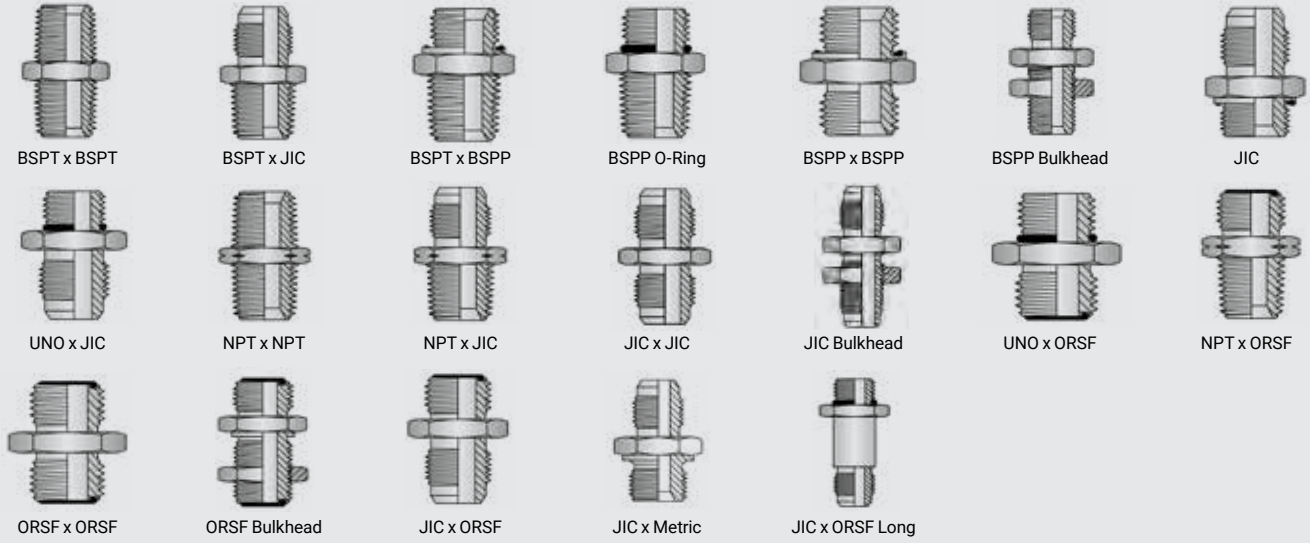

Plugs

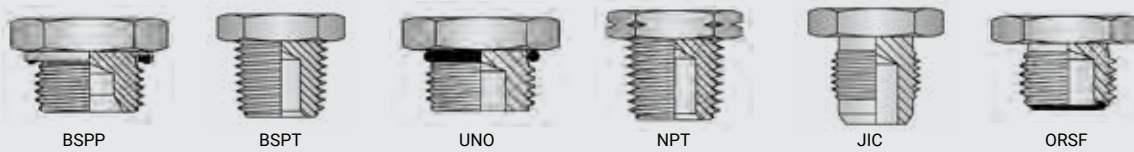

Caps



Sockets



Adaptor Unions – 90°

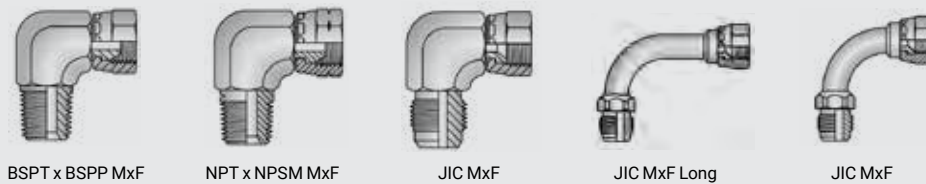

Adaptor Unions – Straight





Adaptors

Adaptor Unions – 45°



BSPT x BSPP MxF



NPT x NPSM M F



JIC MxF

Reducing Bushes



BSPT x BSPT



BSPP x BSPP

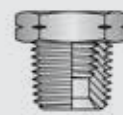

NPT x NPT

Adaptors – Fixed



BSPT MxF



BSPT x JIC MxF



NPT x JIC MxF

Tube Reducers

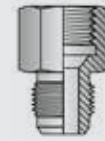

JIC MxF

Elbows – 45°



BSPT MxM



BSPP x JIC MxM



BSPT x JIC MxM



UNO x JIC MxM



NPT x JIC MxM

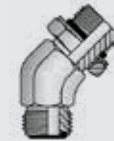

UNO x ORSF MxM

Elbows – 90°



BSPT MxF



BSPT MxM



BSPT FxF

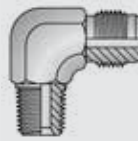

BSPT x JIC MxM

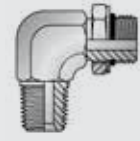

BSPT x UNO MxM

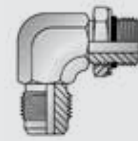

UNO x JIC MxM

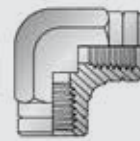

NPT FxF

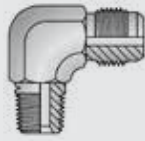

NPT x JIC MxM



JIC MxM

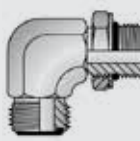

UNO x ORSF MxM



NPT x ORSF MxM

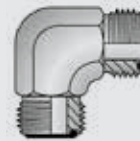

ORSF MxM

Tees

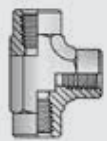

BSPT Female

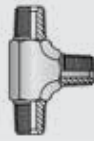

BSPT Male



UNC x JIC Male

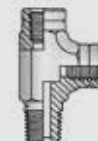

NPT MxFxF

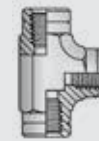

NPT Female

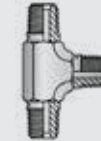

NPT Male

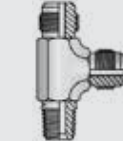

NPT x JIC Male

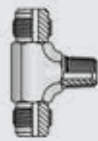

JIC x BSPT Male

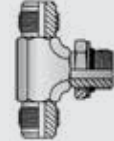

JIC x UNCF Male

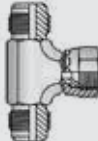

JIC MxMxF

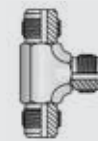

JIC Male

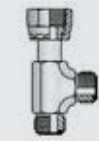

ORSF MxFxM

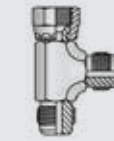

JIC MxFxM

SAE Flange Fittings



C61 FLG x JIC M



C61 FLG x JIC M 45



C62 FLG x JIC M 90



C62 FLG x JIC M

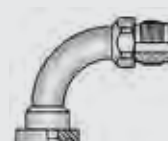

C62 FLG x JIC M 90

Hydraulic Hose, Fittings, Manufacture & Repairs available in-house at Bishops

MADE TO ORDER



Hydraulic Adaptors



Hydraulic Fittings



**Hydraulic
Crimp Fittings**



One Piece Fittings

Sales & Service

PORT MORESBY 325 1088
LAE 472 3799
KIMBE 983 5500

MADANG 422 1344
MT HAGEN 545 1990
KOKOPO 982 9911

Email sales@bishopbro.com.pg
www.bishopbro.com.pg



PUSH-IN TUBE FITTINGS

PUSH-IN MALE ELBOW CONNECTORS

- One-touch fittings
- White plastic
- Imperial connectors are fitted with thread sealant



Size	Bishops Code	Size	Bishops Code
4mm x M5-0.8	38630045	8mm x 3/8" BSP	38630083
6mm x M5-0.8	38630065	8mm x 1/4"	38430150
4mm x 1/8" BSP	38630041	10mm x 1/4" BSP	38630102
6mm x 1/8" BSP	38630061	10mm x 3/8" BSP	38630103
6mm x 1/4" BSP	38630062	12mm x 1/4" BSP	38630122
6mm x 3/8" BSP	38630063	12mm x 3/8" BSP	38630123
8mm x 1/8" BSP	38630081	12mm x 1/2" BSP	38630124
8mm x 1/4" BSP	38630082	1/2" x 1/2" BSP	38630126

PUSH-IN DOUBLE UNIVERSAL MALE ELBOWS

- One-touch fittings
- White plastic body
- Thread sealant
- Copper-free



Size	Bishops Code
6mm x 1/8" BSP	38635061
6mm x 1/4" BSP	38635062
8mm x 1/8" BSP	38635081
8mm x 1/4" BSP	38635082
10mm x 1/4" BSP	38635102
12mm x 1/4" BSP	38635122

PUSH-IN TEE UNIONS

- One-touch fittings
- White plastic body
- Copper-free
- Max. working pressure: 1.0MPa



Size	Bishops Code	Size	Bishops Code
4mm	38686004	10mm	38686010
6mm	38686006	12mm	38686012
8mm	38686008	-	-

PUSH-IN MALE BRANCH TEES

- One-touch fittings
- White plastic body
- Max. working pressure: 1.0MPa
- Imperial tees are copper-free and fitted with thread sealant



Size	Bishops Code	Size	Bishops Code
4mm x M5-0.8	38686045	8mm x 1/4"	38686082
6mm x M5-0.8	38686065	8mm x 3/8"	38686083
6mm x 1/8"	38686061	10mm x 1/4"	38686102
6mm x 1/4"	38686062	10mm x 3/8"	38686103
6mm x 3/8"	38686063	12mm x 1/4"	38686122
8mm x 1/8"	38686081	12mm x 1/2"	38686020

PUSH-IN TUBE UNIONS

- Metric and imperial
- One-touch fittings
- White plastic body
- Max. working pressure: 1.0MPa



Size	Bishops Code	Size	Bishops Code
METRIC			
4mm	38694004	10mm	38694010
6mm	38694006	12mm	38694012
8mm	38694008	-	-
IMPERIAL			
5/16"	38494040	-	-

PUSH-IN TUBE CONNECTORS

- One-touch fittings
- White plastic body
- Copper-free
- Max. working pressure: 1.0MPa



Size	Bishops Code
4 x 6mm	38694034
6 x 8mm	38694036
8 x 10mm	38694038
10 x 12mm	38694040

PUSH-IN MALE CONNECTORS

- One-touch fittings
- Max. working pressure: 1.0MPa
- Imperial connectors are fitted with thread sealant



Size	Bishops Code	Size	Bishops Code
4mm x M5-0.8	38638045	8mm x 3/8"	38638083
6mm x M5-0.8	38638065	10mm x 1/8"	38638101
4mm x 1/4"	38638042	10mm x 1/4"	38638102
6mm x 1/8"	38638061	10mm x 3/8"	38638103
6mm x 1/4"	38638062	12mm x 1/4"	38638122
6mm x 3/8"	38638063	12mm x 3/8"	38638123
8mm x 1/8"	38638081	12mm x 1/2"	38638124
8mm x 1/4"	38638082	1/2" x 1/2"	38638126

PUSH-IN TUBE BULKHEAD UNIONS

- Brass



Size	Bishops Code	Size	Bishops Code
3/16"	38494070	3/8"	38494100
1/4"	38494080	1/2"	38494110
5/16"	38494090	-	-

FEMALE COUPLINGS – SEALING

- Steel
- Airline fittings
- Ryco–Nitto interchange



Size (BSP)	Bishops Code
¼"	37408010
⅜"	37408070
½"	37408130

MALE COUPLINGS – SEALING

- Steel
- Airline fittings
- Ryco – Nitto interchange



Size (BSP)	Bishops Code
¼"	37408020
⅜"	37408080
½"	37408140

HOSE TAIL COUPLINGS – SEALING

- Steel
- Airline fittings
- Ryco–Nitto interchange



Size (BSP)	Bishops Code
¼"	37408030
⅜"	37408090
½"	37408150

MALE PLUG ADAPTORS – NON-SEALING

- Steel
- Airline fittings
- Ryco–Nitto interchange



Size (BSP)	Bishops Code
¼"	37408050
⅜"	37408110
½"	37408170

FEMALE PLUG ADAPTORS – NON-SEALING

- Steel
- Airline fittings
- Ryco–Nitto interchange



Size (BSP)	Bishops Code
¼"	37408040
⅜"	37408100
½"	37408160

HOSE TAIL PLUG ADAPTORS – NON-SEALING

- Steel
- Airline fittings
- Ryco–Nitto interchange



Size	Bishops Code
¼"	37408060
⅜"	37408120
½"	37408180

AIRLINE DISTRIBUTOR BLOCKS

- Nitto style fittings



2 Port

Description	Bishops Code
2 Port Manifold	37408920
4 Port Manifold	37408960

GET MORE AT BISHOPS ▶



COMPRESSORS

Page 328



HOSE FITTINGS – BRASS & STAINLESS STEEL

BARBED MALE HOSE TAILS

- No. P3
- Brass airline fittings



Size (Hose x BSPT)	Bishops Code	Size (Hose x BSPT)	Bishops Code
1/4" x 1/8"	38038030	1/2" x 1/8"	38038140
1/4" x 1/4"	38038040	1/2" x 1/4"	38038150
1/4" x 3/8"	38038060	1/2" x 3/8"	38038170
1/4" x 1/2"	38038070	1/2" x 1/2"	38038180
5/16" x 1/4"	38038072	1/2" x 3/4"	38038190
5/16" x 3/8"	38038074	3/4" x 1/2"	38038210
3/8" x 1/8"	38038080	3/4" x 3/4"	38038220
3/8" x 1/4"	38038090	3/4" x 1"	38038230
3/8" x 3/8"	38038110	1" x 1/2"	38038240
3/8" x 1/2"	38038120	1" x 3/4"	38038250
3/8" x 3/4"	38038130	1" x 1"	38038260

BARBED FEMALE HOSE TAILS

- No. P10
- Brass airline fittings



Size (Hose x BSP)	Bishops Code	Size (Hose x BSP)	Bishops Code
1/4" x 1/4"	38038300	3/8" x 1/2"	38038380
1/4" x 3/8"	38038320	1/2" x 1/4"	38038390
1/4" x 1/2"	38038330	1/2" x 3/8"	38038400
5/16" x 1/4"	38038332	1/2" x 1/2"	38038410
5/16" x 3/8"	38038336	3/4" x 1/2"	38038420
3/8" x 1/4"	38038350	3/4" x 3/4"	38038430
3/8" x 3/8"	38038370	–	–

BARBED MALE ELBOWS

- No. P6
- Brass airline fittings



Size (Hose x BSPT)	Bishops Code	Size (Hose x BSPT)	Bishops Code
1/4" x 3/8"	38530180	3/8" x 1/2"	38530200
3/8" x 3/8"	38530195	–	–

BARBED MALE BRANCH TEES

- No. P12
- Brass airline fittings
- Two-way tees



Size (Hose x BSPT)	Bishops Code
3/8" x 3/8"	38086220

BARBED HOSE TEES

- No. P14
- Brass airline fittings
- Three-way tees



Size	Bishops Code
3/8"	38586130

BARBED HOSE TAIL JOINERS

- No. P7
- Brass airline fittings



Size	Bishops Code	Size	Bishops Code
3/16"	38034010	3/8"	38034030
1/4"	38034020	1/2"	38034040
5/16"	38034025	3/4"	38034050

316 STAINLESS STEEL BARBED MALE HOSETAIL JOINERS

- No. P3SS



Size (BSP)	Bishops Code	Size (BSP)	Bishops Code
3/8"	38354130	1"	38354160
1/2"	38354140	1 1/2"	38354170
3/4"	38354150	2"	38354180

MALE ELBOW ADAPTORS

- No. 48
- Brass



Size (BSPT x BSPT)	Bishops Code	Size (BSPT x BSPT)	Bishops Code
1/8" x 1/8"	38030700	1/4" x 1/4"	38030720
1/8" x 1/4"	38030710	1/2" x 1/2"	38030750

FEMALE EXTRUDED TEE ADAPTORS

- No. 35
- Brass



Size (BSP)	Bishops Code	Size (BSP)	Bishops Code
1/4"	38086040	3/8"	38086050

MALE & FEMALE REDUCING BUSH ADAPTORS

- No. 24
- Brass



Size (BSPT x BSP)	Bishops Code	Size (BSPT x BSP)	Bishops Code
1/4" x 1/8"	38070010	3/4" x 1/4"	38070080
3/8" x 1/8"	38070020	3/4" x 3/8"	38070090
3/8" x 1/4"	38070030	3/4" x 1/2"	38070100
1/2" x 1/8"	38070040	1" x 1/4"	38070105
1/2" x 1/4"	38070050	1" x 1/2"	38070110
1/2" x 3/8"	38070060	1" x 3/4"	38070120

FEMALE REDUCING HEX SOCKETS

- No. 29
- Brass



Size (BSP x BSP)	Bishops Code	Size (BSP x BSP)	Bishops Code
1/4" x 1/8"	38078010	1/2" x 3/8"	38078060
3/8" x 1/8"	38078020	3/4" x 1/2"	38078070
3/8" x 1/4"	38078030	1" x 3/4"	38078080

MALE REDUCING NIPPLES

- No. 73
- Brass



Size (BSPT x BSPT)	Bishops Code	Size (BSPT x BSPT)	Bishops Code
1/4" x 1/8"	38074010	1/2" x 3/8"	38074050
3/8" x 1/8"	38074020	3/4" x 3/8"	38074060
3/8" x 1/4"	38074030	3/4" x 1/2"	38074070
1/2" x 1/4"	38074040	-	-

MALE HEX NIPPLES

- No. 27
- Brass
- BSPT



Size (BSPT)	Bishops Code	Size (BSPT)	Bishops Code
1/8"	38054010	1/2"	38054040
1/4"	38054020	3/4"	38054050
3/8"	38054030	1"	38054060

MALE & FEMALE ADAPTORS

- No. 72
- Brass



Size (BSP x BSPT)	Bishops Code	Size (BSP x BSPT)	Bishops Code
1/4" x 1/8"	38010020	1/2" x 1/4"	38010070
1/4" x 1/4"	38010030	1/2" x 3/8"	38010080
3/8" x 1/4"	38010050	1/2" x 1/2"	38010090
3/8" x 3/8"	38010060	3/4" x 1/2"	38010100

MALE TAPER PLUG ADAPTORS

- No. 64
- Brass



Size	Bishops Code	Size	Bishops Code
1/8" BSP	38066010	1/2" BSP	38066040
1/4" BSP	38066020	3/4" BSP	38066050
3/8" BSP	38066030	-	-



PIPE FITTINGS – BRASS & GALVANISED

FEMALE HEX SOCKETS

- No. 26
- Brass



Size	Bishops Code	Size	Bishops Code
1/8" BSP	38078090	1/2" BSP	38078120
1/4" BSP	38078100	3/4" BSP	38078130
3/8" BSP	38078110	1" BSP	38078140

BRASS OLIVES

- No. 1
- Brass
- Compression sleeve for metal tube



Size	Bishops Code	Size	Bishops Code
1/4"	38562015	3/8"	38562025
5/16"	38562020	1/2"	38562030

330 PIECE BRASS OLIVE KIT – METRIC & IMPERIAL

- Suits copper and nylon tube
 - 6mm copper and nylon
- Includes:**
- 12 sizes: Copper 1/8" to 1/2" and nylon 3/16" to 3/8"

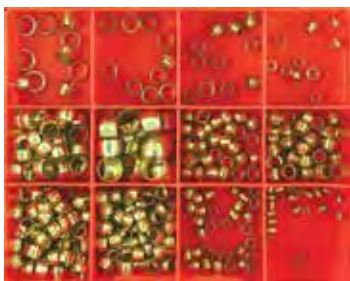

Item Code	Bishops Code
CA1412	40410680

MALE & FEMALE REDUCING BUSH ADAPTORS

- No. 24
- Galvanised



Item Code	Size	Bishops Code
01-2412	100 x 50mm (4" x 2" BSP)	38070252
10-G2442	100 x 80mm (4" x 3" BSP)	38070254

SAE 45° FLARE FITTINGS – FLARE NUTS

- No. 6 Standard and No. 6S short types
- Imperial fitting
- Brass



STANDARD		SHORT	
Size	Bishops Code	Size	Bishops Code
3/8"	38558025	3/8"	38558040
1/2"	38558030	–	–

IT'S TIME TO SADDLE UP

When it comes time to secure your piping, many different clamp options become available. The most popular option is the use of a saddle bracket.

Secure Positioning

Saddle brackets allow you to secure piping directly to a surface. This reduces costs associated with the purchasing of unnecessary components. By securing a pipe directly to the surface, you are able to reduce the space taken up by the system, making this method perfect for tight spaces such as within walls or under flooring.

Working Load

When securing your pipe, it is important to determine the load of the pipe when full in order to make a decision on how many brackets will be needed. When mounting your saddles, ensure they are spaced equally to spread the load out and secure the pipe effectively.

If you're chasing stainless steel U-bolts, contact your Bishops representative.

Can't find the little things you need in this catalogue? Give us a call – we'll get 'em for you. Find them at Bishops!



GET MORE AT BISHOPS



FASTENER GRAB KITS

From Page 289



PIPE FITTINGS & ACCESSORIES

Pipe:

- Used for industrial plumbing and fire hydrant piping systems, provides water to landing valves, hose reels, and hydrant risers typically located in stairwells or building cavities, suitable for mains or independent water supply

Pipe Fittings:

- Roll grooved pipe couplings and fittings system is a fast and reliable way to join pipe for both wet and dry applications
- Providing a flexible movement to the piping system and easily adapted to suit standard or light walled pipe

Gasket Lube:

- Specifically formulated where rubber gaskets are fitted in hot, dry, and wet weather, also used in areas where high levels of water quality are not required such as sewerage, irrigation, and fire control systems
- Standards: AS 4020-1999

Petro Tape:

- Petro petrolatum coating systems were developed for the protection of metal surfaces in the most severe environments. They are designed to be applied over wire brushed surfaces in exposed, underground, and underwater applications
- Range in sizes: 50 to 150mm wide



Roll Grooved Pipe Fittings



Mechanical Tee

Roll Grooved Couplings

Minsup® Gasket Lube

Petro Tape

CONTACT YOUR BISHOPS REPRESENTATIVE FOR MORE INFORMATION & TO ORDER THESE PRODUCTS

304 STAINLESS STEEL FEMALE ELBOWS

- Screwed fittings
- Female x female connections



90° ELBOW		45° ELBOW	
Size (BSP)	Bishops Code	Size (BSP)	Bishops Code
1/4"	38330305	3/8"	38330510
3/8"	38330310	1/2"	38330515
1/2"	38330315	3/4"	38330520
3/4"	38330320	1"	38330525
1"	38330325	1 1/2"	38330530
1 1/2"	38330330	2"	38330535
2"	38330335	-	-

316 STAINLESS STEEL FEMALE TEES

- Service pressure: 150psi



Size (BSP)	Bishops Code	Size (BSP)	Bishops Code
1/8"	38386300	3/4"	38386320
1/4"	38386305	1"	38386325
3/8"	38386310	1 1/2"	38386330
1/2"	38386315	2"	38386335

304 STAINLESS STEEL MALE & FEMALE ELBOWS 90°

- Fig 4
- Screwed fittings



Size (BSP)	Bishops Code	Size (BSP)	Bishops Code
1/8"	38330400	3/4"	38330420
1/4"	38330405	1"	38330425
3/8"	38330410	1 1/2"	38330430
1/2"	38330415	2"	38330435

316 STAINLESS STEEL REDUCING BUSH ADAPTORS

- Fig 9



Size (BSP x BSP)	Bishops Code	Size (BSP x BSP)	Bishops Code
3/8" x 1/4"	38370020	1" x 3/4"	38370310
1/2" x 1/4"	38370040	1" x 1 1/2"	38370315
1/2" x 3/8"	38370050	2" x 1 1/2"	38370320
3/4" x 1/2"	38370070	-	-



PIPE FITTINGS – STAINLESS & BLACK STEEL

HYDRAULICS, VALVES, HOSES & FITTINGS

316 STAINLESS STEEL SOCKETS

- 150lb
- No. 26



Size (BSP)	Bishops Code	Size (BSP)	Bishops Code
3/8"	38378510	1"	38378525
1/2"	38378515	1 1/2"	38378530
3/4"	38378520	2"	38378535

316 STAINLESS STEEL MACHINED HEX SOCKETS

- Fig 15



Size (BSP)	Bishops Code	Size (BSP)	Bishops Code
1/8"	38378300	3/4"	38378330
3/8"	38378310	1"	38378340
1/2"	38378320	2"	38378360

316 STAINLESS STEEL HEX NIPPLES

- No. 27SS



Size (BSP)	Bishops Code	Size (BSP)	Bishops Code
1/8"	38354010	1"	38354060
1/4"	38354020	1 1/2"	38354070
3/8"	38354030	1 1/4"	38354075
1/2"	38354040	2"	38354080
3/4"	38354050	-	-

316 STAINLESS STEEL FEMALE BARREL UNIONS

- ANSI B16.5
- Fig 6



Size (BSP)	Bishops Code	Size (BSP)	Bishops Code
3/8"	38394310	1"	38394325
1/2"	38394315	1 1/2"	38394330
3/4"	38394320	2"	38394335

316 STAINLESS STEEL TUBE CAPS

- FIG12
- Screwed fittings



Size	Bishops Code	Size	Bishops Code
3/8"	38318020	1 1/2"	38318060
1/2"	38318030	2"	38318070
3/4"	38318040	3"	38318080
1"	38318050	-	-

316 STAINLESS STEEL HEX PLUGS

- Fig 8



Size (BSP)	Bishops Code	Size (BSP)	Bishops Code
1/8"	38366300	1"	38366325
3/8"	38366310	1 1/2"	38366330
1/2"	38366315	2"	38366335
3/4"	38366320	-	-

EQUAL TEE BSP – 1,000LB

- Black steel



Soft Metric	Nominal Bore	Pipe O.D.	Bishops Code
6mm	1/8"	10.30mm	68086005
8mm	1/4"	13.70mm	68086010
10mm	3/8"	17.20mm	68086015
15mm	1/2"	21.30mm	68086020
20mm	3/4"	26.70mm	68086025
25mm	1"	33.40mm	68086030
32mm	1 1/4"	42.20mm	68086035
40mm	1 1/2"	48.30mm	68086040
50mm	2"	60.30mm	68086045

FEMALE X FEMALE ELBOW FITTINGS

- Black steel
- Female x female



Size	Bishops Code	Size	Bishops Code
6mm (1/4" BSP)	68030005	25mm (1" BSP)	68030030
10mm (3/8" BSP)	68030015	32mm (1 1/4" BSP)	68030040
12mm (1/2" BSP)	68030012	40mm (1 1/2" BSP)	68030045
20mm (3/4" BSP)	68030025	50mm (2" BSP)	68030050

NIPPLES BSP – 1,000LB

- Black steel

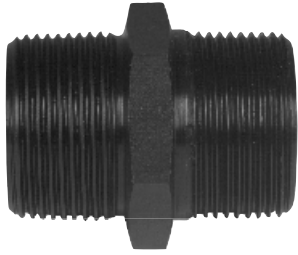

Soft Metric	Nominal Bore	Pipe O.D.	Bishops Code
6mm	¼"	13.7mm	68054005
10mm	⅜"	17.2mm	68054015
32mm	1¼"	42.2mm	68054035
40mm	1½"	48.3mm	68054040
50mm	2"	60.3mm	68054045

REDUCING NIPPLES BSP – 1,000LB

- Black steel

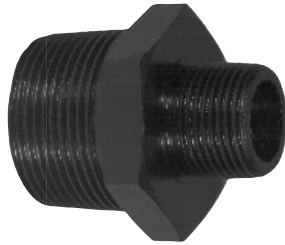

Soft Metric	Nominal Bore	Pipe O.D. Large	Pipe O.D. Small	Bishops Code
8 x 6mm	¼" x ⅜"	13.70mm	10.30mm	68074005
10 x 8mm	⅜" x ½"	17.20mm	13.70mm	68074010
15 x 8mm	½" x ⅜"	21.30mm	13.70mm	68074015
15 x 10mm	½" x ⅝"	21.30mm	17.20mm	68074020
20 x 10mm	¾" x ⅝"	26.70mm	17.20mm	68074025
20 x 15mm	¾" x ½"	26.70mm	21.30mm	68074030
25 x 15mm	1" x ½"	33.40mm	21.30mm	68074035
25 x 20mm	1" x ¾"	33.40mm	26.70mm	68074040
32 x 25mm	1¼" x 1"	42.20mm	33.40mm	68074045
40 x 25mm	1½" x 1"	48.30mm	33.40mm	68074050
50 x 40mm	2" x 1½"	60.30mm	48.30mm	68074055

FEMALE X FEMALE UNIONS BSP – 1,000LB

- Brass seats where available
- Black steel



Soft Metric	Size	Bishops Code	Soft Metric	Size	Bishops Code
8mm	¼"	68094005	25mm	1"	68094025
10mm	⅜"	68094010	32mm	1¼"	68094030
15mm	½"	68094015	40mm	1½"	68094040
20mm	¾"	68094020	50mm	2"	68094045

SOCKETS BSP – 1,000LB

- Black steel

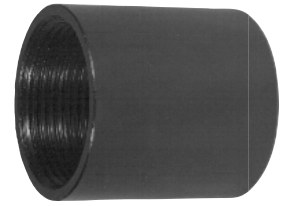

Soft Metric	Nominal Bore	Pipe O.D.	Bishops Code
6mm	⅜"	10.30mm	68078005
8mm	½"	13.70mm	68078010
10mm	⅝"	17.20mm	68078015
15mm	¾"	21.30mm	68078020
20mm	1"	26.70mm	68078025
32mm	1¼"	42.20mm	68078035
40mm	1½"	48.30mm	68078040
50mm	2"	60.30mm	68078045

BUSHES BSP – 600 TO 1,000LB

- 1,000psi all sizes to 2" nominal bore
- 600psi rating for 2½"
- Black steel



Soft Metric	Nominal Bore	Pipe O.D. Large	Pipe O.D. Small	Bishops Code
8 x 6mm	¼" x ⅜"	13.70mm	10.30mm	68070005
10 x 8mm	⅜" x ½"	17.20mm	13.70mm	68070010
15 x 8mm	½" x ⅜"	21.30mm	13.70mm	68070015
15 x 10mm	½" x ⅝"	21.30mm	17.20mm	68070020
20 x 8mm	¾" x ⅜"	26.70mm	13.70mm	68070025
20 x 10mm	¾" x ⅝"	26.70mm	17.20mm	68070030
20 x 15mm	¾" x ½"	26.70mm	21.30mm	68070035
25 x 20mm	1" x ¾"	33.40mm	26.70mm	68070040
40 x 25mm	1½" x 1"	48.30mm	33.40mm	68070050
50 x 25mm	2" x 1"	60.30mm	33.40mm	68070055
50 x 40mm	2" x 1½"	60.30mm	48.30mm	68070060

PLUGS BSP – 1,000LB

- Black steel



Soft Metric	Nominal Bore	Pipe O.D.	Bishops Code
6mm	⅜"	10.30mm	68066005
10mm	⅝"	17.20mm	68066015
20mm	¾"	26.70mm	68066025
25mm	1"	33.40mm	68066030
38mm	1½"	48.30mm	68066035
50mm	2"	60.30mm	68066040

BALL VALVES

DIFFERENT TYPES OF VALVES & THEIR COMMON USES

Ball Valves are commonly used in shut off applications and are quarter turn operated with a spherical plug with an opening. When the opening is in line with the flow, fluid is able to pass through. When the opening is perpendicular to the flow, fluid stops. The ball is controlled by a valve handle.



Butterfly Valves are a simple and versatile quarter turn operated valve. A disc with a centre axis turns 90°. In an open position the disc sits perpendicular to the flow and fluid is able to pass through. In a closed position the disc sits in line with the flow. The butterfly valve can be operated easily and quickly either manually or with a pneumatic actuator.



Gate Valves are controlled by a metal gate that slides up and down to manipulate flow. When the gate is fully open the flow is equal to the area of the pipe. When the gate is fully closed, flow stops. Gate valves are recommended for on/off use, as partly open conditions can lead to erosion of the gate.



Check Valves have two ports, one for fluid to enter, the other for fluid to leave. Check valves work automatically and are not controlled externally. Instead they have a 'cracking pressure'. This means the fluid must reach a certain pressure before it will operate.



Foot Valve is a marriage between a check valve and a straining element. The valve works in the same way as the check valve, working once a certain pressure is reached. A straining element is added to the 'fluid in' side, stopping the movement of particles that may block hose or piping.

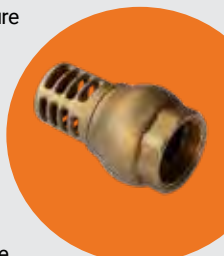

Cock Valve, also known as plug valve, blocks flow with a cone-shaped plug. When rotated the plug moves aside allowing fluid to flow through.

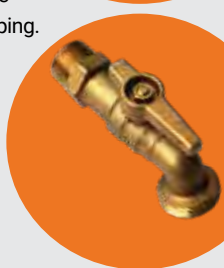

Float Valve has the role to control the inflow of fluid in a storage tank. It is controlled by a float that sits on the top of the liquid surface. When the liquid level decreases the float drops and the valve opens, letting in liquid to refill the tank to the desired level.



BRASS BALL VALVES – FULL BORE

- Female/female connections
- Nickel plated brass body with chrome plated brass ball
- PTFE seals
- Plastic coated handle for extra comfort
- Non-AGA approved



Working Pressure	Size	Bore Size	Bishops Code
435psi (30 bar)	¼" BSP	6mm	39602020
435psi (30 bar)	½" BSP	12mm	39602040
360psi (25 bar)	2" BSP	50mm	39602090
230psi (16 bar)	2½" BSP	65mm	39602095

PREMIUM BRASS BALL VALVES – FULL BORE

- Female/female connections
- Nickel plated brass body with chrome plated brass ball
- PTFE seals
- Plastic coated handle for extra comfort
- AGA approved up to 2"



Working Pressure	Size	Bore Size	Bishops Code
710psi (49 bar)	¾" BSP	10mm	39602030
435psi (30 bar)	¾" BSP	20mm	39602050
435psi (30 bar)	1" BSP	25mm	39602060
360psi (25 bar)	1¼" BSP	32mm	39602070
360psi (25 bar)	1½" BSP	40mm	39602080
230psi (16 bar)	3" BSP	75mm	39602100

BALL VALVES BSP – 3 PIECE

- 316 Stainless steel
- Full port
- 800psi WOG
- Max. temperature: 180°C



Soft Metric	Nominal Bore	Bishops Code
15mm	½"	39610004
20mm	¾"	39610006
25mm	1"	39610008
40mm	1½"	39610010
50mm	2"	39610012

HIGH PRESSURE BALL VALVES

- Inteva series
- Female/female connections
- Carbon steel body and ball with a yellow Bichromate finish on the body
- Designed for use in oil hydraulic applications
- Suitable for industrial, agricultural and public works machinery areas
- Comes with mounting holes to allow attachment to most surfaces
- Working pressure: 6,000psi (400 bar)



Size	Nominal Dia.	Bishops Code
¼" BSP	6	39610106
⅜" BSP	10	39610108
½" BSP	13	39610110
¾" BSP	20	39610120
1" BSP	25	39610125

BRASS GATE VALVES

- Hot pressed brass body with a steel handle
- Female/female connections
- Working temperature: 0°C to 120°C



39604030

Working Pressure	Size	Bishops Code	Working Pressure	Size	Bishops Code
145psi (10 bar)	½" BSP	39604020	145psi (10 bar)	1½" BSP	39604060
145psi (10 bar)	¾" BSP	39604030	145psi (10 bar)	2" BSP	39604070
145psi (10 bar)	1" BSP	39604040	230psi (16 bar)	2½" BSP	39604075
145psi (10 bar)	1¼" BSP	39604050	230psi (16 bar)	3" BSP	39604080

1, 2 & 3 PIECE BALL VALVES

One Piece

One piece ball valves are cast as one piece. In comparison to other ball valve options, they are relatively inexpensive. Their one piece construction makes them difficult to service. In most cases they are easier to replace entirely, than to service.



Two Piece

A two piece ball valve is constructed using two pieces. The ball being held in position by a body stud. This makes servicing the valve simpler, but does disrupt the pipeline. As the two pieces are fixed together, the force and the internal temperature can affect the seal tightness causing leaks.



Three Piece

A three piece ball valve consists of two end caps and a body. The three piece design allows for the centre part of the valve, containing the ball, to be easily removed from the pipeline to allow for servicing.



GET MORE AT BISHOPS

PIPE WRENCHES

From Page 198





HOW TO SELECT A PRESSURE GAUGE

1. Accuracy

Accuracy is defined as a percentage of the full-scale range. While requirements differ from one industry to another, the following are general guidelines:

- Test gauges and standards: 0.25% through 0.10% full scale accuracies
- Critical processes: 0.5% full scale accuracy
- General industrial processes: 1.0% accuracy
- Less critical commercial uses: 2.0% accuracy
- Refer to ASME B40.100 or the DIN specifications for more information on accuracy

2. Dial Size

Pressure gauge dial sizes range from 1½" to 16" diameters. Generally, readability requirements, space limitations and required gauge accuracy determine dial size. Accuracies of 0.25% to 0.5% generally have dial sizes of 4½" or larger since more dial graduations are required.

3. Case Style/Material

Environmental considerations include ambient temperature, airborne particulates, condensation, humidity, water and chemicals, all of which can affect gauge performance.

Ambient temperature may affect the accuracy and integrity of the gauge. Gauges are available either temperature compensated or non-temperature compensated. Ambient conditions may require that the gauge be isolated from temperature extremes. When required, the gauge should be isolated from temperature extremes with a flexible line assembly.

When ambient conditions are corrosive, contain a large number of particulates, or the gauge will be exposed to a wet or humid environment, specify a gauge that is weatherproof/hermetically sealed or liquid filled.

4. Media/Wetted Parts

The wetted parts of the pressure gauge, the Bourdon tube and socket, must be compatible with the process media. If not compatible with the wetted parts of the gauge, corrosion will occur. Corrosion of gauge wetted parts will eventually cause gauge failure and possibly safety issues. When the gauge wetted parts are not compatible with the process media, a diaphragm should be considered.

5. Connection Size

Gauges are available with a variety of connections including NPT, DIN, JIS, BSP & SAE. Process pressure gauges with 4½" dial sizes or larger are most often supplied with a ½" NPT connection to best support the gauge. Factors to consider when selecting a pressure gauge connection include process pressures, gauge size and weight, space limitations, leak integrity and past experience.

6. Connection Location

Consider the following mounting options when selecting a pressure gauge:

- Bottom entry connection
- Back entry connection
- Wall/surface mounting
- U-clamp flush mounting for back entry connection
- Front flange flush mounting for back entry connection

7. Pressure Ranges

ASME B40.100 recommends that normal operating pressure be confined to 25%–75% of the scale. If pulsation is present in the process, maximum operating gauge pressure should not exceed 50% of the full-scale range.

To properly select a pressure gauge, consider the gauge process, range, environment, accuracy, dial size, connection and mounting requirements.

PRESSURE GAUGES – BACK ENTRY



- For use with regulators for setting output pressure
- Graduated both in bars and psi with a max. reading of 200psi (14 bar), in intervals of 5psi (0.20 bar) and is accurate to within 5%
- Male threads on the centre back and fit female threads on the regulator
- Gauge has a steel casing with clear glass lens and internal components made from brass



Item Code	Thread Size	Bishops Code
A2G02	½" BSP	73682005
A2G08	¾" BSP	73682010

PRESSURE GAUGES – BOTTOM ENTRY

- Grade 304 stainless steel case
- Glycerine-filled to protect against vibration and extend life of the gauge
- Liquid filled gauges are not suitable where oxidising agents such as oxygen, chlorine, nitric acid and hydrogen peroxide are being used
- Diameter: 63mm



73682240

Description	Working Pressure	Bishops Code
¼" BSPT	0–100kPa (0–15psi)	73682210
¼" BSPT	0–250kPa (0–36psi)	73682220
¼" BSPT	0–600kPa (0–85psi)	73682230
¼" BSPT	0–1,000kPa (0–145psi)	73682240
¼" BSPT	0–1,000kPa (0–140psi)	73682145
¼" BSPT With ⅙" BSPT Adaptor	0–1,000kPa (0–140psi)	73682148
¼" BSPT	0–1,600kPa (0–230psi)	73682250
¼" BSPT	0–10,000kPa (0–1,500psi)	73682550
¼" BSPT	0–25,000kPa (0–3,600psi)	73682625
¼" BSPT With ⅙" BSPT Adaptor	0–25,000kPa (0–3,600psi)	73682600
¼" BSPT	0–40,000kPa (0–5,800psi)	73682630

PRESSURE GAUGES – BOTTOM ENTRY

- Dry gauge
- Stainless steel case
- Diameter: 50mm
- Port size: ¼" BSP



Working Pressure	Bishops Code
0–800kPa (0–115psi)	73682185

STAINLESS STEEL PRESSURE GAUGES – BOTTOM ENTRY

- Stainless steel casing
- Liquid filled to protect against vibration and extend life of the gauge
- Liquid filled gauges are not suitable where oxidising agents such as oxygen, chlorine, nitric acid and hydrogen peroxide are being used
- Face diameter: 150mm
- Port size: ½" NPT



Working Pressure	Bishops Code
0–6,000kPa (0–870psi)	73682740

OIL PRESSURE GAUGES – BOTTOM ENTRY

- Grade 304 stainless steel case
- Liquid filled to protect against vibration and extend life of the gauge
- Liquid filled gauges are not suitable where oxidising agents such as oxygen, chlorine, nitric acid and hydrogen peroxide are being used
- Diameter: 63mm
- Port size: ¼" BSP



Working Pressure	Bishops Code
0–300kPa (0–43psi)	73682150
0–16,000kPa (0–2,320psi)	73682180

AIRLINE AIR PRESSURE GAUGE

- Back entry
- Oil filled
- Max. working pressure: 1.0MPa
- 50mm



Size	Bishops Code
¼" BSP	73682160

PRESSURE TEST PUMP

- Max. pressure: 860psi
- Max. volume: 12L



Item Code	Bishops Code
60005	64090150

THE DIFFERENCE BETWEEN AIR FILTERS, AIR REGULATORS & AIR LUBRICATORS

Air Filter cleans compressed air by trapping solid particles and separating liquids, such as oil and water. Filters are installed in the air line upstream of regulators, lubricators, and all pneumatically-powered tools and equipment. They remove contaminants from pneumatic systems, preventing damage to equipment and reducing production losses due to contaminant-related downtime.



Air Pressure Regulators control fluid pressure in compressed air systems. Regulators are also known as pressure reducing valves (PRVs). Pressure regulators maintain a constant output pressure regardless of input pressure variations and demands made on the system by downstream components.



Air Lubricators add controlled quantities of oil into the compressed air system to reduce the friction between moving components within air tools and other equipment. Adding lubrication oil to the system also clears compressor oils that travel through the system in vapor form. To prevent build-up of oil within system components, mineral oils are added to the system to flush away the deposits.



AIRLINE FILTERS

- Modular type
- Polycarbonate bowl
- No mounting bracket or auto drain
- Max. working pressure: 1.0MPa
- Ambient and fluid temp: -5°C to 60°C



Port Size	Bishops Code
¾" BSP	73675070
½" BSP	73675080



FILTER REGULATORS, LUBRICATORS & DRAIN VALVES

AIRLINE FILTER REGULATORS

- Modular type regulators
- Polycarbonate bowl with standard guard
- No backflow function
- With mounting bracket and pressure gauge
- Pressure range: 0.05–0.85MPa



Description	Port Size	Bishops Code
AC40 Filter Regulator	½" BSP	73675015
AW30 Filter Regulator	¼" BSP	73675020
AW30 Filter Regulator	¾" BSP	73675030
AW40 Filter Regulator	½" BSP	73675040
AW40 Filter Regulator with Auto Drain	¾" BSP	73675050

FILTER REGULATOR COMBINATIONS



- Air filter is used to separate dust, dirt, moisture and other contaminants from compressed air
- Filter has a die cast aluminium body, polycarbonate bowl with a steel bowl guard and a high performance sintered bronze filtering element
- Filter is designed with a separator and shield for efficient moisture separation. It is combined with a regulator which maintains a steady outlet pressure, unaffected by variations/fluctuations in the inlet pressure
- Regulators have a non-raising "Press to Lock" adjusting knob for locking at any set pressure
- Regulators work on a diaphragm operated, relieving type mechanism with pressure compensated by balanced poppet
- Wetted components: Aluminium, bronze, brass, steel, acetal, polycarbonate, stainless steel and nitrile
- Comes with bracket and gauge



Item Code	Port Size	Flow Rate	Pressure Gauge Port Size	Bowl Size	Bishops Code
FRC146134-S/GB	¼"	1,800L/min (63cfm)	½"	32ml	73677020
FRC146234-S/GB	¾"	2,200L/min (77cfm)	¾"	32ml	73677030
FRC156334-S/GB	½"	3,000L/min (106cfm)	½"	44ml	73677040
FRC176434-S/GB	¾"	4,250L/min (149cfm)	¾"	165ml	73677050

AIRLINE LUBRICATORS

- Modular type
- Metric thread
- Polycarbonate bowl
- No mounting option
- Max. working pressure: 1.0MPa



Port Size	Bishops Code
½" BSP	73675140

AIR LUBRICATORS

- Used to feed lubricants to pneumatic equipment
- Maintains a constant oil-to-air density over a wide range of flow
- Fog/MicroMist type, up to 50' pipe runs
- Die cast aluminium head, polycarbonate bowl with a steel bowl guard
- The head is fitted with oil drop indicator, oil drop controller and oil filling plug
- Wetted components: aluminium, bronze, steel, acetal, polycarbonate, stainless steel and nitrile
- Designed for best performance with 32 grade oil



Item Code	Port Size	Flow Rate	Bowl Size	Dimensions	Bishops Code
L1361	¼" BSP	1,350L/min (48cfm)	20ml	135(h) x 40(w)mm	73677110
L1462	¾" BSP	3,000L/min (106cfm)	57ml	157(h) x 55(w)mm	73677130
L1563	½" BSP	5,650L/min (200cfm)	152ml	190(h) x 70(w)mm	73677140
L1764	¾" BSP	7,200L/min (318cfm)	200ml	273(h) x 90(w)mm	73677150

AUTO DRAIN VALVES

- Drains the condensate water automatically
- Features a provision in the valve for manual drain off
- Unlike an electrical auto drain valve, these float type auto drain valve operates only when the condensate is collected and drains only the condensate



Item Code	Suits	Bishops Code
A2D01	¼" Units Miniature – Model Series F13, FS13	73677670
A2D02	¾" Units Intermediate – Model Series F14, FS14	73677675
A2D03	½" Units Standard – Model Series F15, FS15	73677680
A2D04	¾" Units Heavy Duty – Model Series F17, FS17	73677685

GET MORE AT BISHOPS



VALVE LOCKOUTS

Page 51

PAINT MARKERS

Page 353



BUCKETS

Page 408

DIMENSIONS

Dimensions & Lengths of Thread

Matching conical outside thread with cylindrical inside thread

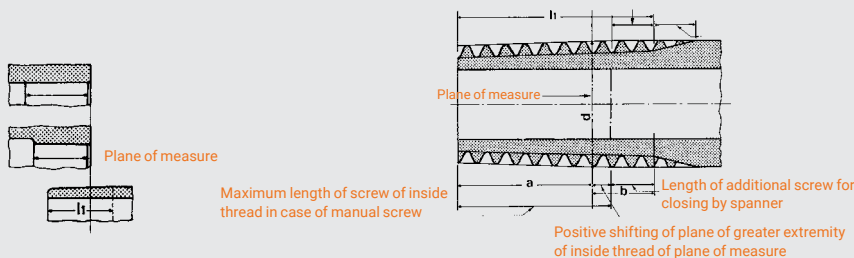

Outside Pipe Thread		Pipe Size															
Description		1/8"	1/4"	3/8"	1/2"	3/4"	1"	1 1/4"	1 1/2"	2"	2 1/2"	3"	3 1/2"	4"	5"	6"	
Length of Measure (a)	Size Of Thread In Plane Of Measure (d)	9.728	13.157	16.662	20.995	26.441	33.249	41.91	47.803	59.614	75.184	87.884	100.33	113.03	138.43	163.83	
	Nominal Dimension	4.0	6.0	6.4	8.2	9.5	10.4	12.7	12.7	15.9	17.5	20.6	22.2	25.4	28.6	28.6	
	Shiftings mm≈	±0.9	±1.3	±1.3	±1.8	±1.8	±2.3	±2.3	±2.3	±2.3	±3.5	±3.5	±3.5	±3.5	±3.5	±3.5	
	Shiftings Threads	±1	±1	±1	±1	±1	±1	±1	±1	±1	±1 1/2	±1 1/2	±1 1/2	±1 1/2	±1 1/2	±1 1/2	
	Dimension Max.≈	4.9	7.3	7.7	10	11.3	12.7	15	15	18.2	21	24.1	25.7	28.9	32.1	32.1	
Tolerance of Screw (b)	mm≈	2.5	3.7	3.7	5	5	6.4	6.4	6.4	7.5	9.2	9.2	9.2	10.4	11.5	11.5	
	Threads	2 3/4	2 3/4	2 3/4	2 3/4	2 3/4	2 3/4	2 3/4	2 3/4	3 1/2	4	4	4	4 1/2	5	5	
Length min. of Useful Thread (L1)	For a Nominal 6.5	9.7	10.1	13.2	14.5	16.8	19.1	19.1	-	23.4	26.7	29.8	31.4	35.8	40.1	40.1	
	For a Max.	7.4	11	11.4	15	16.3	19.1	21.4	21.4	25.7	30.2	33.3	34.9	39.3	43.6	43.6	
	For a Min.	5.6	8.4	8.8	11.4	12.7	14.5	16.8	16.8	21.1	23.2	26.3	27.9	32.3	36.6	36.6	
Inside Pipe Thread																	
Length of Useful Thread (L2)	7.4	11.0	11.4	15.0	16.3	19.1	21.4	21.4	-	25.7	30.2	33.3	34.9	39.3	43.6	43.6	
Shifting of Plane Of Extremity	mm ≈	±1.1	±1.7	±1.7	±2.3	±2.3	±2.9	±2.9	±2.9	±2.9	±3.5	±3.5	±3.5	±3.5	±3.5	±3.5	
On The Plane of Measure	Threads	±1 1/4	±1 1/4	±1 1/4	±1 1/4	±1 1/4	±1 1/4	±1 1/4	±1 1/4	±1 1/4	±1 1/2	±1 1/2	±1 1/2	±1 1/2	±1 1/2	±1 1/2	
Shifting on Sizes Of Middle Thread And Of Stone		±0.071	±0.104	±0.104	±0.142	±0.142	±0.180	±0.180	±0.180	±0.180	±0.217	±0.217	±0.217	±0.217	±0.217	±0.217	

Bolt & Stud Dimensions for ASA (USAS) Flanges to USAS B16.5

150lb. Flanges																					
Nominal Pipe Size	1/2"	3/4"	1"	1 1/4"	1 1/2"	2"	2 1/2"	3"	3 1/2"	4"	5"	6"	8"	10"	12"	14"	16"	18"	20"	24"	
Number of Bolts	4	4	4	4	4	4	4	4	8	8	8	8	8	12	12	12	16	16	20	20	
Dia. of Bolts	1/2"	1/2"	1/2"	1/2"	5/8"	5/8"	5/8"	5/8"	5/8"	5/8"	3/4"	3/4"	3/4"	7/8"	7/8"	1"	1"	1 1/8"	1 1/8"	1 1/4"	1 1/4"
Machine Bolts	1 3/4"	2"	2"	2 1/4"	2 1/4"	2 1/4"	3"	3"	3"	3"	3 1/4"	3 1/4"	3 1/4"	3 3/4"	3 3/4"	4"	4 1/4"	4 1/4"	4 3/4"	5 1/4"	5 3/4"
Stud Bolts	2 1/4"	2 1/4"	2 1/2"	2 1/2"	2 3/4"	3"	3"	3 1/4"	3 1/2"	3 1/2"	3 1/2"	3 3/4"	3 3/4"	4 1/2"	4 1/2"	5"	5 1/4"	5 1/4"	6"	6 3/4"	6 3/4"
300lb. Flanges																					
Number of Bolts	4	4	4	4	4	8	8	8	8	8	8	12	12	16	16	20	20	24	24	24	
Dia. of Bolts	1/2"	5/8"	5/8"	5/8"	3/4"	5/8"	3/4"	3/4"	3/4"	3/4"	3/4"	3/4"	7/8"	1"	1 1/8"	1 1/8"	1 1/4"	1 1/4"	1 1/4"	1 1/4"	1 1/2"
Machine Bolts	2	2 1/2"	2 1/2"	2 3/4"	3	3	3 1/4"	3 1/2"	3 3/4"	3 3/4"	4	4 1/4"	4 3/4"	5 1/4"	5 3/4"	6	6 1/2"	6 3/4"	7	7 3/4"	7 3/4"
Stud Bolts	2 1/2"	2 3/4"	3"	3"	3 1/4"	3 1/2"	3 3/4"	4"	4 1/4"	4 1/4"	4 1/2"	4 3/4"	5 1/4"	6"	6 1/2"	6 3/4"	7 1/4"	7 1/2"	8"	9"	9"
400lb. Flanges																					
Number of Bolts	4	4	4	4	4	8	8	8	8	8	8	12	12	16	16	20	20	24	24	24	
Dia. of Bolts	1/2"	5/8"	5/8"	5/8"	3/4"	5/8"	3/4"	3/4"	7/8"	7/8"	7/8"	7/8"	1"	1 1/8"	1 1/4"	1 1/4"	1 3/8"	1 3/8"	1 1/2"	1 3/4"	1 3/4"
Machine Bolts	3"	3"	3"	3"	4"	4"	4"	4"	5"	5"	5"	5"	6"	7"	7"	8"	8"	8"	9"	10"	10"
600lb. Flanges																					
Number of Bolts	4	4	4	4	4	8	8	8	8	8	8	12	12	16	20	20	20	20	24	24	
Dia. of Bolts	1/2"	5/8"	5/8"	5/8"	3/4"	5/8"	3/4"	3/4"	7/8"	7/8"	1"	1"	1 1/8"	1 1/4"	1 1/4"	1 3/8"	1 1/2"	1 5/8"	1 5/8"	1 3/4"	1 3/4"
Machine Bolts	3"	3 1/4"	3 1/2"	3 3/4"	4"	4"	4 1/2"	4 3/4"	5 1/4"	5 1/2"	6 1/4"	6 1/2"	7 1/2"	8 1/4"	8 1/2"	9"	9 3/4"	10 1/2"	11 1/4"	12 3/4"	12 3/4"
900lb. Flanges																					
Number of Bolts	4	4	4	4	4	8	8	8	8	8	12	12	12	16	20	20	20	20	20	20	
Dia. of Bolts	3/4"	3/4"	7/8"	7/8"	1"	7/8"	1"	7/8"	1 1/8"	1 1/4"	1 1/8"	1 3/8"	1 3/8"	1 3/8"	1 1/2"	1 3/8"	1 3/8"	1 3/8"	2"	2 1/4"	2 1/4"
Machine Bolts	4"	4 1/4"	4 3/4"	4 3/4"	5 1/4"	5 1/2"	6"	6 3/4"	7 1/2"	7 1/2"	8 1/2"	9"	9 3/4"	10 1/2"	11"	12 3/4"	13 1/2"	13 1/2"	17"	17"	17"
1,500lb. Flanges																					
Number of Bolts	4	4	4	4	4	8	8	8	8	8	12	12	12	12	16	16	16	16	16	16	
Dia. of Bolts	3/4"	3/4"	7/8"	7/8"	1"	7/8"	1"	1 1/8"	1 1/4"	1 1/2"	1 3/8"	1 3/8"	1 3/8"	1 3/8"	2"	2 1/4"	2 1/2"	2 3/4"	3"	3 1/2"	3 1/2"
Machine Bolts	4"	4 1/4"	4 3/4"	4 3/4"	5 1/4"	5 1/2"	6"	6 3/4"	7 1/2"	8 1/2"	9 1/2"	10"	11 1/4"	13 1/4"	14 3/4"	16"	17 1/2"	19 3/4"	21"	24"	24"
2,500lb. Flanges																					
Number of Bolts	4	4	4	4	4	8	8	8	8	8	12	12	12	12	-	-	-	-	-	-	
Dia. of Bolts	3/4"	3/4"	7/8"	1"	1 1/8"	1"	1 1/8"	1 1/4"	1 1/2"	1 3/4"	2"	2"	2 1/2"	2 3/4"	-	-	-	-	-	-	
Machine Bolts	4 3/4"	4 3/4"	5 1/4"	5 3/4"	6 1/2"	6 3/4"	7 1/2"	8 1/2"	9 3/4"	11 1/2"	13 1/2"	15"	19"	21"	-	-	-	-	-	-	

Machine bolt lengths include height of point; stud-bolt lengths do not include height of point. Length shown is for raised face joints



FLANGES

HYDRAULICS, VALVES, HOSES & FITTINGS

ANSI CLASS 150 BLIND FLANGE

- ANSI flanges specification: ANSI B 16.5
- Raised face thickness: 1.6mm
- Material: A105N Carbon Steel

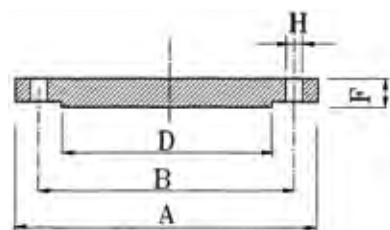

Soft Metric	Nom. Bore	A	B	D	F	H	Bolt Size	Number of Holes	Approx. Weight	Bishops Code
50mm	2"	152.5	120.6	92.0	19.1	20.0	5/8"	4	2.3kg	68289010
100mm	4"	228.7	190.5	157.2	23.8	20.0	5/8"	8	7.7kg	68289020
150mm	6"	276.5	241.3	216.0	25.5	22.0	3/4"	8	12.0kg	68289025
200mm	8"	343.0	298.4	269.9	28.6	22.0	3/4"	8	21.4kg	68289030
250mm	10"	406.5	361.9	232.9	30.2	26.0	7/8"	12	30.5kg	68289035

SLIP ON PLATE FLANGE – TABLE D

- Specification: AS2129
- Material: Steel

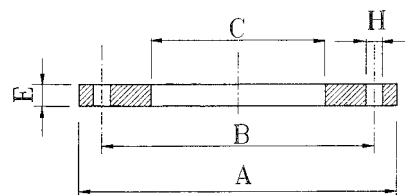
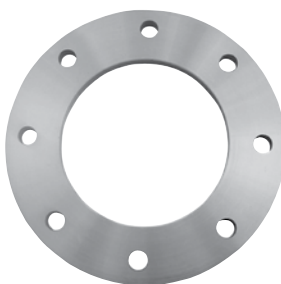

Soft Metric	Imperial Size	A	B	C	E	H	Bolt Size	Number of Holes	Approx. Weight	Bishops Code
150mm	6"	279mm	235mm	167mm	13mm	18mm	M16	8	3.9kg	68284045
200mm	8"	337mm	292mm	221mm	13mm	18mm	M16	8	5.2kg	68284050

SLIP ON PLATE FLANGE – TABLE E

- Specification: AS2129
- Material: 316 Stainless Steel

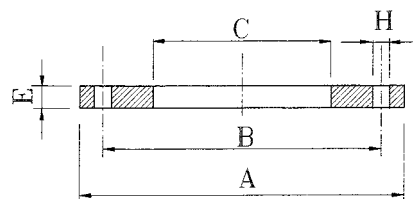
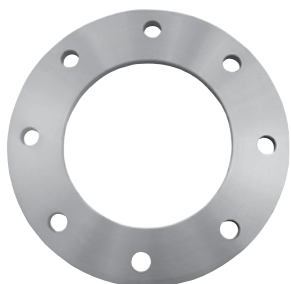

Soft Metric	Imperial Size	A	B	C	E	H	Bolt Size	Number of Holes	Approx. Weight	Bishops Code
25mm	1"	114	83	35	12	14	M12	4	0.9kg	68285025
50mm	2"	152	114	62	12	18	M16	4	1.4kg	68285050
65mm	2½"	165	127	78	12	18	M16	4	1.5kg	68285065
80mm	3"	184	146	90	12	18	M16	4	2.0kg	68285080

KNOW YOUR STANDARDS & CLASSES

Flanges are made to different standards, each with their own classes to match a wide series of pipe dimensions. Before choosing your flange, make sure it matches the standard and class on your pipes to ensure everything lines up perfectly. Never pick and mix between different classes, they just won't fit and alteration to the flange will drastically affect its integrity.

The two standards sold at Bishops are; AS 2129 and ANSI B16.5. If you need a special size or even a different material, Bishops can source what you need. Give your local branch a call.

AS 2129 is an Australian Standard that is used by most Australian manufacturers. These flanges are most commonly made of mild steel. The classes within this standard are labelled Tables. The most common classes which are offered by Bishops include Table D, Table E and Table H.

ANSI B16.5 is an American Standard. These flanges are most commonly made of carbon steel A105. The classes within this standard are labelled by the standard name; ANSI. The most common classes within this standard are ANSI 150, ANSI 300, ANSI 600, ANSI 900 and ANSI 1500. These also come in Raised Face and Ring Type Joint (RTJ).

EXPAND YOUR Flange Knowledge

The most common flanges Bishops supply are flat face and raised face. But what sets them apart?

Flat face flanges are only used in low temperature, low pressure applications. The flat surface allows for full contact across the whole face of the two flanges. Only use full face gaskets with full face flanges to ensure full and equal contact between the two flanges.

Raised face flanges are widely used for all forged steel equipment and valves. The face on these flanges has two levels; the inner level and outer level. The inner level forms the contact surface whilst the outer level forms the non-contact area. The extra level allows for more thread which in turn enables the bolt to apply more force and create a much tighter seal. When fitting a gasket, make sure that it lines up with the inner level in both size and shape.

Temperature °C	Flange Pressure Chart (kPa)							
	ANSI B16.5				AS 2129			
	Class 150	Class 300	Class 600	Class 900	Class 1500	Table D	Table E	Table H
-29 to 38	1,960	5,110	10,210	15,320	25,530	700	1,400	3,500
50	1,920	5,010	10,020	15,020	25,040	700	1,400	3,500
100	1,770	4,640	9,280	13,910	23,190	700	1,400	3,500
150	1,580	4,520	9,050	13,570	22,610	700	1,400	3,500
200	1,400	4,380	8,760	13,150	21,910	700	1,400	3,500
250	1,210	4,170	8,340	12,520	20,860	650	1,300	3,300
300	1,020	3,870	7,750	11,620	19,370	570	1,100	2,900
350	840	3,700	7,390	11,090	18,480	500	950	2,400
375	740	3,650	7,290	10,940	18,230	450	900	2,200
400	650	3,450	6,900	10,350	17,250	400	800	2,000
425	560	2,880	5,750	8,630	14,380	350	700	1,700
450	470	2,000	4,010	6,010	10,020	-	-	1,300
475	370	1,350	2,710	4,060	6,770	-	-	900
500	280	880	1,760	2,640	4,400	-	-	-
525	190	520	1,040	1,550	2,590	-	-	-
540	130	330	650	980	1,630	-	-	-

GET MORE AT BISHOPS ▶



PIPE REPAIR TAPE

Page 459



GASKETS

Page 459



GASKET SEALANTS

Page 467



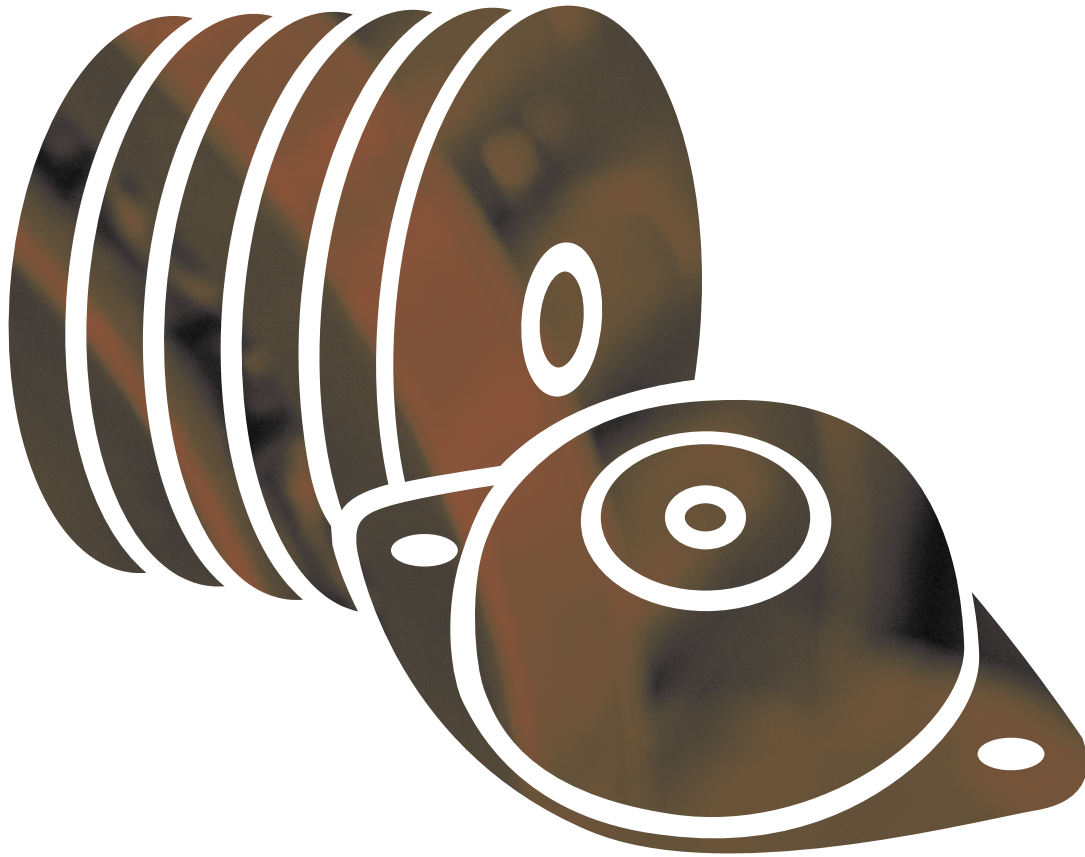

13

BEARINGS, SEALS & TRANSMISSION PRODUCTS

BEARINGS

Groove Ball Bearings	510
Roller Bearings	511-512
Wide Inner Bearings	513
Adaptor Sleeves, Block Housings & Seals.....	513-514

POWER TRANSMISSION

V-Pulleys	514
V-Belts	516-517
Roller Chain	519
Electric Motors.....	519
O-Rings.....	520
Circlips & E-Clips.....	520
Key Steel & Woodruff Keys	521
Shim.....	521



BALL BEARINGS

DEEP GROOVE BALL BEARINGS

- Normal clearance
- Note:**
- 2Z = 2 metal shields
- 2RS = 2 rubber seals



TIMKEN

BEARINGS, SEALS & TRANSMISSION PRODUCTS

Item Code	Bore Dia.	Outside Dia.	Width	Bishops Code	Item Code	Bore Dia.	Outside Dia.	Width	Bishops Code	Item Code	Bore Dia.	Outside Dia.	Width	Bishops Code
625-2Z	5mm	16mm	5mm	20104130	6305-2Z	25mm	62mm	17mm	20806210	6013-2RS	65mm	100mm	18mm	20802510
625-2RS	5mm	16mm	5mm	20104120	6305-2RS	25mm	62mm	17mm	20806190	6213-2Z	65mm	120mm	23mm	20804477
635-2Z	5mm	19mm	6mm	20104230	6006-2Z	30mm	55mm	13mm	20802170	6213-2RS	65mm	120mm	23mm	20804445
626-2RS	6mm	19mm	6mm	20104150	6006-2RS	30mm	55mm	13mm	20802160	6313-2Z	65mm	140mm	33mm	20806720
607-2RS	7mm	19mm	6mm	20104040	6206-2Z	30mm	62mm	16mm	20804180	6313-2RS	65mm	140mm	33mm	20806710
627-2RS	7mm	22mm	7mm	20104160	6206-2RS	30mm	62mm	16mm	20804170	6014-2Z	70mm	110mm	20mm	20802600
608-2Z	8mm	22mm	7mm	20104070	6306-2Z	30mm	72mm	19mm	20806290	6014-2RS	70mm	110mm	20mm	20802580
608-2RS	8mm	22mm	7mm	20104060	6306-2RS	30mm	72mm	19mm	20806270	6214-2Z	70mm	125mm	24mm	20804490
628-2Z	8mm	24mm	8mm	20104190	6306-2RS	30mm	72mm	19mm	20806275	6214-2RS	70mm	125mm	24mm	20804485
628-2RS	8mm	24mm	8mm	20104180	6007-2Z	35mm	62mm	14mm	20802210	6314-2Z	70mm	150mm	35mm	20806750
609-2RS	9mm	24mm	7mm	20104080	6007-2RS	35mm	62mm	14mm	20802200	6314-2RS	70mm	150mm	35mm	20806740
629-2Z	9mm	26mm	8mm	20104210	6207-2Z	35mm	72mm	17mm	20804230	6015-2Z	75mm	115mm	20mm	20802630
629-2RS	9mm	26mm	8mm	20104200	6207-2RS	35mm	72mm	17mm	20804220	6015-2RS	75mm	115mm	20mm	20802610
6000-ZZ	10mm	26mm	8mm	20802020	6307-2Z	35mm	80mm	21mm	20806360	6215-2Z	75mm	130mm	25mm	20804527
6000-2RS	10mm	26mm	8mm	20802010	6307-2RS	35mm	80mm	21mm	20806350	6215-2RS	75mm	130mm	25mm	20804510
6200-2Z	10mm	30mm	9mm	20804010	6307-2RS	35mm	80mm	21mm	20806355	6315-2RS	75mm	160mm	37mm	20806790
6200-2RS	10mm	30mm	9mm	20804005	6008-2Z	40mm	68mm	15mm	20802240	6016-2RS	80mm	125mm	22mm	20802660
6300-2RS	10mm	35mm	11mm	20806010	6008-2RS	40mm	68mm	15mm	20802230	6216-2Z	80mm	140mm	26mm	20804540
6001-2Z	12mm	28mm	8mm	20802045	6208-2Z	40mm	80mm	18mm	20804275	6216-2RS	80mm	140mm	26mm	20804535
6001-2RS	12mm	28mm	8mm	20802040	6208-2RS	40mm	80mm	18mm	20804260	6316-2RS	80mm	170mm	39mm	20806800
6201-2Z	12mm	32mm	10mm	20804035	6208-2RS	40mm	80mm	18mm	20804265	6017-2RS	85mm	130mm	22mm	20802700
6201-2RS	12mm	32mm	10mm	20804025	6308-2Z	40mm	90mm	23mm	20806440	6217-2Z	85mm	150mm	28mm	20804555
6301-2Z	12mm	37mm	12mm	20806035	6308-2RS	40mm	90mm	23mm	20806410	6217-2RS	85mm	150mm	28mm	20804560
6301-2RS	12mm	37mm	12mm	20806030	6009-2Z	45mm	75mm	16mm	20802310	6317-2Z	85mm	180mm	41mm	20806830
6002-2Z	15mm	32mm	9mm	20802060	6009-2RS	45mm	75mm	16mm	20802290	6317-2RS	85mm	180mm	41mm	20806820
6002-2RS	15mm	32mm	9mm	20802050	6209-2Z	45mm	85mm	19mm	20804305	6018-2Z	90mm	140mm	24mm	20802770
6202-2Z	15mm	35mm	11mm	20804065	6209-2RS	45mm	85mm	19mm	20804300	6218-2Z	90mm	160mm	30mm	20804580
6202-2RS	15mm	35mm	11mm	20804060	6309-2Z	45mm	100mm	25mm	20806530	6218-2RS	90mm	160mm	30mm	20804575
6302-2Z	15mm	42mm	13mm	20806050	6309-2RS	45mm	100mm	25mm	20806490	6318-2Z	90mm	190mm	43mm	20806860
6302-2RS	15mm	42mm	13mm	20806040	6010-2RS	50mm	80mm	16mm	20802350	6318-2RS	90mm	190mm	43mm	20806850
6003-2Z	17mm	35mm	10mm	20802085	6210-2Z	50mm	90mm	20mm	20804335	6019-2RS	95mm	145mm	24mm	20802800
6003-2RS	17mm	35mm	10mm	20802080	6210-2RS	50mm	90mm	20mm	20804330	6219-2RS	95mm	170mm	32mm	20804600
6203-2Z	17mm	40mm	12mm	20804090	6310-2Z	50mm	110mm	27mm	20806550	6219-2Z	95mm	170mm	32mm	20804602
6203-2RS	17mm	40mm	12mm	20804085	6310-2RS	50mm	110mm	27mm	20806540	6319-2RS	95mm	200mm	45mm	20806890
6303-2Z	17mm	47mm	14mm	20806090	6011-2RS	55mm	90mm	18mm	20802400	6319-2Z	95mm	200mm	45mm	20806910
6303-2RS	17mm	47mm	14mm	20806080	6211-2Z	55mm	100mm	21mm	20804375	6020-2RS	100mm	150mm	24mm	20802820
6004-2Z	20mm	42mm	12mm	20802100	6211-2RS	55mm	100mm	21mm	20804365	6220-2RS	100mm	180mm	34mm	20804605
6004-2RS	20mm	42mm	12mm	20802090	6311-2Z	55mm	120mm	29mm	20806600	6320-2RS	100mm	215mm	47mm	20806930
6204-2Z	20mm	47mm	14mm	20804120	6311-2RS	55mm	120mm	29mm	20806590	6022-2Z	110mm	170mm	28mm	20802900
6204-2RS	20mm	47mm	14mm	20804110	6012-2Z	60mm	95mm	18mm	20802480	6022-2RS	110mm	170mm	28mm	20802890
6304-2Z	20mm	52mm	15mm	20806150	6012-2RS	60mm	95mm	18mm	20802470	6222-2Z	110mm	200mm	38mm	20804650
6304-2RS	20mm	52mm	15mm	20806130	6212-2Z	60mm	110mm	22mm	20804425	6026	130mm	200mm	33mm	20802940
6005-2RS	25mm	47mm	12mm	20802130	6212-2RS	60mm	110mm	22mm	20804400	6326	130mm	280mm	58mm	20806995
6205-2Z	25mm	52mm	15mm	20804150	6312-2Z	60mm	130mm	31mm	20806670	-	-	-	-	-
6205-2RS	25mm	52mm	15mm	20804140	6312-2RS	60mm	130mm	31mm	20806650	-	-	-	-	-

DEEP GROOVE BALL BEARINGS WITH SNAP RING GROOVE



TIMKEN

Item Code	Bore Dia.	Outside Dia.	Width	Bishops Code	Item Code	Bore Dia.	Outside Dia.	Width	Bishops Code	Item Code	Bore Dia.	Outside Dia.	Width	Bishops Code
6000-ZNR	10mm	26mm	8mm	20802030	6307-ZNR	35mm	80mm	21mm	20806380	6012-ZNR	60mm	95mm	18mm	20802490
6202-ZNR	15mm	35mm	11mm	20804070	6208-ZNR	40mm	80mm	18mm	20804290	6312-ZNR	60mm	130mm	31mm	20806680
6203-ZNR	17mm	40mm	12mm	20804100	6308-ZNR	40mm	90mm	23mm	20806470	6213-ZNR	65mm	120mm	23mm	20804465
6303-ZNR	17mm	47mm	14mm	20806110	6009-ZNR	45mm	75mm	16mm	20802330	6313-ZNR	65mm	140mm	33mm	20806730
6304-ZNR	20mm	52mm	15mm	20806170	6209-ZNR	45mm	85mm	19mm	20804320	6214-ZNR	70mm	125mm	24mm	20804500
6205-ZNR	25mm	52mm	15mm	20804155	6309-ZNR	45mm	100mm	25mm	20806510	6215-ZNR	75mm	130mm	25mm	20804525
6305-ZNR	25mm	62mm	17mm	20806230	6210-ZNR	50mm	90mm	20mm	20804350	6016-NR	80mm	125mm	22mm	20802690
6206-ZNR	30mm	62mm	16mm	20804205	6310-ZNR	50mm	110mm	27mm	20806570	6216-NR	80mm	140mm	26mm	20804552
6306-ZNR	30mm	72mm	19mm	20806330	6211-ZNR	55mm	100mm	21mm	20804390	6217-ZNR	85mm	150mm	28mm	20804565
6207-ZNR	35mm	72mm	17mm	20804245	6311-ZNR	55mm	120mm	29mm	20806630	6218-ZNR	90mm	160mm	30mm	20804590

SPHERICAL ROLLER BEARINGS – PARALLEL BORE

TIMKEN



Item Code	Bore Dia.	Outside Dia.	Width	Bishops Code	Item Code	Bore Dia.	Outside Dia.	Width	Bishops Code	Item Code	Bore Dia.	Outside Dia.	Width	Bishops Code
22205	25mm	52mm	18mm	21206010	22214	70mm	125mm	31mm	21206110	22322	110mm	240mm	80mm	21206350
22206	30mm	62mm	20mm	21206020	22314	70mm	150mm	51mm	21206280	24024	120mm	180mm	60mm	21214004
21306	30mm	72mm	19mm	21204010	22215	75mm	130mm	31mm	21206120	23024	120mm	180mm	46mm	21210020
22207	35mm	72mm	23mm	21206040	21315	75mm	160mm	37mm	21204095	23124	120mm	200mm	62mm	21210080
21307	35mm	80mm	21mm	21204020	22315	75mm	160mm	55mm	21206290	22224	120mm	215mm	58mm	21206190
22208	40mm	80mm	23mm	21206050	22216	80mm	140mm	33mm	21206130	23224	120mm	215mm	76mm	21210135
21308	40mm	90mm	23mm	21204030	21316	80mm	170mm	39mm	21204100	22324	120mm	260mm	86mm	21206360
22308	40mm	90mm	33mm	21206220	22217	85mm	150mm	36mm	21206140	23026	130mm	200mm	52mm	21210030
22209	45mm	85mm	23mm	21206060	21317	85mm	180mm	41mm	21204110	23126	130mm	210mm	64mm	21210090
21309	45mm	100mm	25mm	21204040	22317	85mm	180mm	60mm	21208070	22226	130mm	230mm	64mm	21206200
22309	45mm	100mm	36mm	21206230	22218	90mm	160mm	40mm	21206150	23028	140mm	210mm	53mm	21210040
21310	50mm	110mm	27mm	21204050	23218	90mm	160mm	52mm	21210110	22228	140mm	250mm	68mm	21206210
22210	50mm	90mm	23mm	21206070	21318	90mm	190mm	43mm	21204120	23228	140mm	250mm	88mm	21210150
22310	50mm	110mm	40mm	21206240	22318	90mm	190mm	64mm	21206330	23030	150mm	225mm	56mm	21210050
22211	55mm	100mm	25mm	21206080	22219	95mm	170mm	43mm	21206160	22230	150mm	270mm	73mm	21206211
21311	55mm	120mm	29mm	21204060	21319	95mm	200mm	45mm	21204130	23230	150mm	270mm	96mm	21210155
22311	55mm	120mm	43mm	21206250	22319	95mm	200mm	67mm	21208090	22232	160mm	290mm	80mm	21206212
22212	60mm	110mm	28mm	21206090	23120	100mm	165mm	52mm	21210078	22332	160mm	340mm	114mm	21206400
21312	60mm	130mm	31mm	21204070	22220	100mm	180mm	46mm	21206170	23036	180mm	280mm	74mm	21210070
22312	60mm	130mm	46mm	21206260	23220	100mm	180mm	60mm	21210120	23140	200mm	340mm	140mm	21210100
22213	65mm	120mm	31mm	21206100	22320	100mm	215mm	73mm	21206340	22240	200mm	360mm	98mm	21206218
21313	65mm	140mm	33mm	21204080	22222	110mm	200mm	53mm	21206180	-	-	-	-	-
22313	65mm	140mm	48mm	21208040	23222	110mm	200mm	70mm	21210130	-	-	-	-	-

SPHERICAL ROLLER BEARINGS – 1:12 TAPERED BORE

TIMKEN



Item Code	Bore Dia.	Outside Dia.	Width	Bishops Code	Item Code	Bore Dia.	Outside Dia.	Width	Bishops Code	Item Code	Bore Dia.	Outside Dia.	Width	Bishops Code
22205K	25mm	52mm	18mm	21404010	22313K	65mm	140mm	48mm	21404290	21320K	100mm	215mm	47mm	21402050
22206K	30mm	62mm	20mm	21404020	22214K	70mm	125mm	31mm	21404100	22320K	100mm	215mm	73mm	21404370
22207K	35mm	72mm	23mm	21404030	22314K	70mm	150mm	51mm	21404300	22222K	110mm	200mm	53mm	21404170
22208K	40mm	80mm	23mm	21404040	22215K	75mm	130mm	31mm	21404110	22322K	110mm	240mm	80mm	21404375
21308K	40mm	90mm	23mm	21402010	21315K	75mm	160mm	37mm	21402035	22224K	120mm	215mm	58mm	21404180
22308K	40mm	90mm	33mm	21404240	22315K	75mm	160mm	55mm	21404310	23224K	120mm	215mm	76mm	21406050
22209K	45mm	85mm	23mm	21404050	22216K	80mm	140mm	33mm	21404120	22324K	120mm	260mm	86mm	21404380
22309K	45mm	100mm	36mm	21404250	22316K	80mm	170mm	58mm	21404320	22226K	130mm	230mm	64mm	21404190
22210K	50mm	90mm	23mm	21404060	22217K	85mm	150mm	36mm	21404130	23226K	130mm	230mm	80mm	21406060
21310K	50mm	100mm	27mm	21402015	22317K VA405	85mm	180mm	60mm	21404330	23028K	140mm	210mm	53mm	21406010
22310K	50mm	110mm	40mm	21404260	22317K	85mm	180mm	60mm	21404340	22228K	140mm	250mm	68mm	21404200
22211K	55mm	100mm	25mm	21404070	22218K	90mm	160mm	40mm	21404140	23228K	140mm	250mm	88mm	21406065
22311K	55mm	120mm	43mm	21404270	22318K	90mm	190mm	64mm	21404350	22232K	160mm	290mm	80mm	21404220
22212K	60mm	110mm	28mm	21404080	22318K VA405	90mm	190mm	64mm	21404360	22234K	170mm	310mm	86mm	21404230
21312K	60mm	130mm	31mm	21402025	22219K	95mm	170mm	43mm	21404150	23144K	220mm	370mm	120mm	21406020
22312K	60mm	130mm	46mm	21404280	22220K	100mm	180mm	46mm	21404160	-	-	-	-	-
22213K	65mm	120mm	31mm	21404090	23220K	100mm	180mm	60mm	21406030	-	-	-	-	-



ROLLER BEARINGS

TAPERED ROLLER BEARINGS

TIMKEN



BEARINGS, SEALS & TRANSMISSION PRODUCTS

Item Code	Bore Dia.	Outside Dia.	Width	Bishops Code	Item Code	Bore Dia.	Outside Dia.	Width	Bishops Code	Item Code	Bore Dia.	Outside Dia.	Width	Bishops Code
30203	17mm	40mm	13.25mm	23504020	33110	50mm	85mm	26mm	23508090	31315	75mm	160mm	40mm	23504510
30303	17mm	47mm	15.25mm	23504250	30210M	50mm	90mm	21.75mm	23504090	32315	75mm	160mm	58mm	23506725
32004X	20mm	42mm	15mm	23506010	32210	50mm	90mm	24.75mm	23506410	32016	80mm	125mm	29mm	23506220
30204M	20mm	47mm	15.25mm	23504030	33210	50mm	90mm	24.75mm	23508190	30216	80mm	140mm	28.25mm	23504150
30304	20mm	52mm	16.25mm	23504270	32012	50mm	95mm	23mm	23506140	32216	80mm	140mm	35.25mm	23506480
32304	20mm	52mm	22.25mm	23506570	30310	50mm	110mm	29.25mm	23504400	30316	80mm	170mm	42.5mm	23504520
320/22	22mm	44mm	15mm	23502010	31310	50mm	110mm	29.25mm	23504410	32316	80mm	170mm	61.5mm	23506730
32005	25mm	47mm	15mm	23506020	32310	50mm	110mm	42.25mm	23506670	32017	85mm	130mm	29mm	23506230
30205	25mm	52mm	16.25mm	23504040	32011	55mm	90mm	23mm	23506130	33117	85mm	140mm	41mm	23508130
32205	25mm	52mm	19.25mm	23506350	33111	55mm	95mm	30mm	23508110	30217	85mm	150mm	30.5mm	23504160
30305	25mm	62mm	18.25mm	23504280	30211	55mm	100mm	22.75mm	23504100	32217	85mm	150mm	38.5mm	23506490
31305	25mm	62mm	18.25mm	23504290	32211	55mm	100mm	26.75mm	23506420	33217	85mm	150mm	49mm	23508230
32305	25mm	62mm	25.25mm	23506580	30311	55mm	120mm	31.5mm	23504420	32317	85mm	180mm	63.5mm	23506740
320/28	28mm	52mm	16mm	23502020	31311	55mm	120mm	31.5mm	23504430	32018	90mm	140mm	32mm	23506250
32006	30mm	55mm	17mm	23506040	32311	55mm	120mm	45.5mm	23506680	33018	90mm	140mm	39mm	23508055
30206	30mm	62mm	17.25mm	23504050	33012	60mm	95mm	27mm	23508020	33118	90mm	150mm	45mm	23508140
32206	30mm	62mm	21.25mm	23506360	33112	60mm	100mm	30mm	23508115	30218	90mm	160mm	32.5mm	23504170
32306	30mm	62mm	25mm	23508150	30212	60mm	110mm	23.75mm	23504110	32218	90mm	160mm	42.5mm	23506500
30306	30mm	72mm	20.75mm	23504300	32212	60mm	110mm	29.75mm	23506440	32318	90mm	190mm	67.5mm	23506745
31306	30mm	72mm	20.75mm	23504320	33212	60mm	110mm	38mm	23508200	33019	95mm	145mm	39mm	23508060
32306	30mm	72mm	28.75mm	23506600	30312	60mm	130mm	33.5mm	23504440	30219	95mm	170mm	34.5mm	23504180
320/32 X/Q	32mm	58mm	17mm	23502050	31312	60mm	130mm	33.5mm	23504450	32219	95mm	170mm	45.5mm	23506510
32007	35mm	62mm	18mm	23506060	32312	60mm	130mm	48.5mm	23506690	32020	100mm	145mm	24mm	23506260
30207	35mm	72mm	18.25mm	23504060	32013	65mm	100mm	23mm	23506160	33020	100mm	150mm	39mm	23508070
32207	35mm	72mm	24.25mm	23506380	33013	65mm	100mm	27mm	23508030	30220	100mm	180mm	37mm	23504190
33207	35mm	72mm	28mm	23508160	30213	65mm	120mm	24.75mm	23504120	32220	100mm	180mm	49mm	23506520
30307	35mm	80mm	22.75mm	23504330	32213	65mm	120mm	32.75mm	23506450	33220	100mm	180mm	63mm	23508260
31307	35mm	80mm	22.75mm	23504350	33213	65mm	120mm	41mm	23508210	32021	105mm	160mm	35mm	23506270
32307	35mm	80mm	32.75mm	23506630	30313	65mm	140mm	36mm	23504460	33021	105mm	160mm	43mm	23508080
32008	40mm	68mm	19mm	23506080	31313	65mm	140mm	36mm	23504470	30221	105mm	190mm	39mm	23504200
30208	40mm	80mm	19.75mm	23504070	32313	65mm	140mm	51mm	23506700	32221	105mm	190mm	53mm	23506525
32208	40mm	80mm	24.75mm	23506390	30214	70mm	125mm	26.25mm	23504130	30222	110mm	200mm	41mm	23504210
33208	40mm	80mm	32mm	23508170	32214	70mm	125mm	33.25mm	23506460	32222	110mm	200mm	56mm	23506530
30308	40mm	90mm	25.25mm	23504360	30314	70mm	150mm	38mm	23504480	32024X	120mm	180mm	38mm	23506280
31308	40mm	90mm	25.25mm	23504370	31314	70mm	150mm	38mm	23504490	30224	120mm	215mm	43.5mm	23504220
32308	40mm	90mm	35.25mm	23506650	32314	70mm	150mm	54mm	23506720	32224	120mm	215mm	61.5mm	23506540
32009	45mm	75mm	20mm	23506100	32014	75mm	110mm	25mm	23506180	32026	130mm	200mm	45mm	23506290
30209	45mm	85mm	20.75mm	23504080	32015	75mm	115mm	25mm	23506200	30226	130mm	230mm	43.75mm	23504230
32209	45mm	85mm	24.75mm	23506400	33015	75mm	115mm	31mm	23508045	32028	140mm	250mm	45mm	23506295
33209	45mm	85mm	32mm	23508180	33115	75mm	125mm	37mm	23508125	32030X	150mm	225mm	48mm	23506300
30309	45mm	100mm	27.25mm	23504380	30215	75mm	130mm	27.25mm	23504140	32230	150mm	270mm	77mm	23506550
31309	45mm	100mm	27.25mm	23504390	32215	75mm	130mm	33.25mm	23506470	32032X	160mm	240mm	51mm	23506310
32309	45mm	100mm	38.25mm	23506660	33215	75mm	130mm	41mm	23508220	32232	160mm	290mm	84mm	23506560
32010	50mm	80mm	20mm	23506110	30315	75mm	160mm	40mm	23504500	32038X	190mm	290mm	64mm	23506318

GET MORE AT BISHOPS ▶



HEAD LAMPS

Page 373



DISPOSABLE GLOVES

Page 10

GET MORE AT BISHOPS 

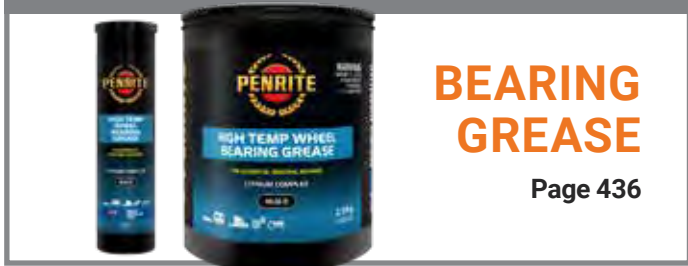

BEARING GREASE

Page 436

WIDE INNER BEARINGS WITH GRUB SCREWS

- Metric bore



Item Code	Bore Dia.	Outside Dia.	Width	Bishops Code
UC204-FYH	20mm (0.8")	47mm (1.85")	31mm (1.2")	22022030
UC205-FYH	25mm (1")	52mm (2.1")	34.1mm (1.3")	22022040
UC206-FYH	30mm (1.2")	62mm (2.4")	38.1mm (1.5")	22022050
UC207-FYH	35mm (1.4")	72mm (2.8")	42.9mm (1.7")	22022060
UC208-FYH	40mm (1.6")	80mm (3.1")	49.2mm (1.9")	22022070
UC209-FYH	45mm (1.8")	85mm (3.3")	49.2mm (1.9")	22022080
UC210-FYH	50mm (2")	90mm (3.5")	51.6mm (2.03")	22022090
UC211-FYH	55mm (2.2")	100mm (3.9")	55.6mm (2.2")	22022100
UC212-FYH	60mm (2.4")	110mm (4.3")	65.1mm (2.6")	22022110
UC213-FYH	65mm (2.6")	120mm (4.7")	68.3mm (2.7")	22022120
UC214-FYH	70mm (2.8")	125mm (4.9")	69.9mm (2.8")	22022130
UC215-FYH	75mm (3")	130mm (5.1")	73.3mm (1.1")	22022140
UC216-FYH	80mm (3.1")	140mm (5.5")	77.9mm (3.1")	22022142

WIDE INNER BEARINGS WITH GRUB SCREWS

- Imperial bore



Item Code	Bore Dia.	Outside Dia.	Width	Bishops Code
UC204-12-FYH	¾"	47mm (1.85")	31mm (1.2")	23234060
UC205-16-FYH	1"	52mm (2.1")	34.1mm (1.3")	23234090
UC206-18-FYH	1 1/8"	62mm (2.4")	38.1mm (1.5")	23234110
UC206-20-FYH	1 1/4"	62mm (2.4")	38.1mm (1.5")	23234130
UC207-20-FYH	1 1/4"	72mm (2.8")	42.9mm (1.7")	23234140
UC208-24-FYH	1 1/2"	80mm (3.1")	49.2mm (1.9")	23234180
UC209-28-FYH	1 3/8"	85mm (3.3")	49.2mm (1.9")	23234220
UC210-32-FYH	2"	90mm (3.5")	51.6mm (2.03")	23234260
UC211-32-FYH	2"	100mm (3.9")	55.6mm (2.2")	23234270
UC212-36-FYH	2 1/4"	110mm (4.3")	65.1mm (2.6")	23234300
UC213-40-FYH	2 1/2"	120mm (4.7")	65.1mm (2.6")	23234340
UC215-48-FYH	3"	130mm	77.8mm	23234380

ADAPTOR SLEEVES – METRIC

- Adaptor sleeves for metric shafts
- 1:12 external taper



Item Code	Internal Dia.	Bishops Code	Item Code	Internal Dia.	Bishops Code
H208	35mm	25506040	H2306	25mm	25506290
H209	40mm	25506050	H2307	30mm	25506300
H210	45mm	25506060	H2308	35mm	25506310
H211	50mm	25506070	H2309	40mm	25506320
H213	60mm	25506090	H2310	45mm	25506330
H215	65mm	25506100	H2311	50mm	25506340
H216	70mm	25506110	H2312	55mm	25506350
H217	75mm	25506120	H2313	60mm	25506360
H218	80mm	25506130	H2314	60mm	25506370
H220	90mm	25506140	H2315	65mm	25506380
H306	25mm	25506150	H2316	70mm	25506390
H307	30mm	25506160	H2317	75mm	25506400
H308	35mm	25506170	H2320	90mm	25506420
H309	40mm	25506180	H2322	100mm	25506430
H310	45mm	25506190	H2324	110mm	25506440
H311	50mm	25506200	H2328	140mm	25506445
H312	55mm	25506210	H3028	125mm	25506450
H313	60mm	25506220	H3124	110mm	25506460
H315	65mm	25506230	H3126	115mm	25506470
H316	70mm	25506240	H3128	125mm	25506475
H317	75mm	25506250	H3132	140mm	25506480
H318	80mm	25506260	H3134	150mm	25506490
H320	90mm	25506270	H3140	180mm	25506500
H322	100mm	25506280	H3144	200mm	25506510

ADAPTOR SLEEVES – IMPERIAL

- Adaptor sleeves for imperial shafts
- 1:12 external taper



Item Code	Internal Dia.	Bishops Code	Item Code	Internal Dia.	Bishops Code
HE206	1"	26004020	HE320	3 1/2"	26004230
HE207	1 1/8"	26004030	HE2305	3/4"	26004240
HE208	1 1/4"	26004040	HE2306	1"	26004260
HE306	1"	26004050	HE2307	1 1/8"	26004270
HE307	1 1/8"	26004052	HE2308	1 1/4"	26004290
HE308	1 1/4"	26004054	HE2309	1 1/2"	26004310
HE309	1 1/2"	26004056	HE2310	1 3/4"	26004320
HE209	1 1/2"	26004060	HE2311	2"	26004330
HE212	2 1/8"	26004090	HE2313	2 1/4"	26004340
HE213	2 1/4"	26004100	HE2315	2 7/8"	26004350
HE215	2 1/2"	26004110	HE2315	2 1/2"	26004360
HE220	3 1/2"	26004150	HE2316	2 3/4"	26004370
HE322	4"	26004155	HE2317	3"	26004380
HE310	1 3/4"	26004160	HE2318	3 1/4"	26004390
HE311	2"	26004170	HE2320	3 1/2"	26004400
HE313	2 1/4"	26004180	HE2322	4"	26004410
HE315	2 1/2"	26004190	HE2324	4 1/4"	26004420
HE316	2 3/4"	26004200	HE3124	4 1/4"	26004870
HE317	3"	26004210	HE3126	4 1/4"	26004875
HE318	3 1/4"	26004220	HE3128	5"	26004880

TIMKEN

TIMKEN



BLOCK HOUSINGS & SEALS & V-PULLEYS

SPLIT PLUMMER BLOCK HOUSINGS – CAST IRON

TIMKEN



BEARINGS, SEALS & TRANSMISSION PRODUCTS

Item Code	Outer Dimensions	Height to Bore Centre	Bishops Code
509NM	205(l) x 85(w) x 109(h)mm	60mm	24604040
510-608NM	205(l) x 90(w) x 113(h)mm	60mm	24604050
511-609NM	255(l) x 95(w) x 128(h)mm	70mm	24604250
512NM	255(l) x 105(w) x 134(h)mm	70mm	24604070
513-611NM	275(l) x 110(w) x 150(h)mm	80mm	24604260
515-612NM	260(l) x 115(w) x 156(h)mm	80mm	24604270
516-613NM	315(l) x 120(w) x 177(h)mm	95mm	24604100
517EM	320(l) x 125(w) x 183(h)mm	95mm	24604110
518-615NM	345(l) x 140(w) x 194(h)mm	100mm	24604115
519-616NM	345(l) x 145(w) x 212(h)mm	112mm	24604290
520-617NM	360(l) x 160(w) x 218(h)mm	112mm	24604120
522-619NM	410(l) x 175(w) x 242(h)mm	125mm	24604130
524-620	410(l) x 185(w) x 271(h)mm	140mm	24604315
526EM	445(l) x 190(w) x 290(h)mm	150mm	24604140
528NM	500(l) x 205(w) x 302(h)mm	150mm	24604138

HOUSING SEAL SETS

- V-ring seals
- To suit plummer block housings only
- Pack of 2



Item Code	Shaft Dia.	Bishops Code	Item Code	Shaft Dia.	Bishops Code
TSNA505A	20mm	24610005	TSNA515A	65mm	24610083
TSNA506A	25mm	24610010	TSNA515G	65mm	24610085
TSNA506G	25mm	24610015	TSNA516G	70mm	24610090
TSNA507A	30mm	24610020	TSNA517A	75mm	24610100
TSNA508A	35mm	24610030	TSNA517G	75mm	24610110
TSNA508G	35mm	24610032	TSNA518A	80mm	24610120
TSNA509A	40mm	24610035	TSNA518G	80mm	24610125
TSNA509G	40mm	24610040	TSNA520A	90mm	24610127
TSNA510A	45mm	24610050	TSNA520G	90mm	24610128
TSNA510G	45mm	24610060	TSNA522A	100mm	24610130
TSNA511A	50mm	24610070	TSNA522G	100mm	24610140
TSNA511G	50mm	24610075	TSNA524G	110mm	24610145
TSNA512A	55mm	24610078	TSNA526A	115mm	24610146
TSNA512G	55mm	24610079	TSNA526G	115mm	24610147
TSNA513A	60mm	24610080	TSNA528G	125mm	24610144
TSNA513G	60mm	24610081	-	-	-

V-PULLEYS – SPA-A

- Tapered bore
- Pulleys conform to ISO 4183 and DIN 2211
- Designed for use with both wedge (narrow) and classical V-belts
- Fine grain cast-iron 260-200
- Eccentricity of OD to bore: DIN 2211 part 1
- Groove side wobble tolerances: DIN 2211 part 1
- Surface roughness: ISO 254
- Balance quality grade: ISO 1940
- Pulley speed: Spoke – 36m/s, Solid – 38m/s



DESCRIPTION EXPLANATION

Section	Pitch Circle Diameter	x	Groove	Bush
SPA	80mm	x	2	1210

Description	Bishops Code	Description	Bishops Code
SPA 80 x 2/1210	51022080	SPA 150 x 1/1610	51021150
SPA 90 x 1/1210	51021090	SPA 150 x 2/2012	51022150
SPA 90 x 2/1610	51022090	SPA 150 x 3/2517	51023150
SPA 95 x 1/1210	51021095	SPA 160 x 2/2012	51022160
SPA 100 x 1/1610	51021100	SPA 180 x 2/2012	51022180
SPA 100 x 2/1610	51022100	SPA 180 x 3/2517	51023180
SPA 100 x 3/1610	51023100	SPA 190 x 2/2012	51022190
SPA 106 x 1/1610	51021106	SPA 200 x 2/2517	51022200
SPA 106 x 2/1610	51022106	SPA 200 x 3/2517	51023200
SPA 112 x 1/1610	51021112	SPA 224 x 1/2012	51021224
SPA 112 x 3/2012	51023112	SPA 224 x 2/2517	51022224
SPA 125 x 1/1610	51021125	SPA 250 x 2/2517	51022250
SPA 125 x 2/1610	51022125	SPA 280 x 2/2517	51022280
SPA 132 x 2/2012	51022132	SPA 280 x 3/3020	51023280
SPA 140 x 2/2012	51022140	SPA 315 x 2/2517	51022315

V-PULLEYS – SPB-B

- Tapered bore
- Pulleys conform to ISO 4183 and DIN 2211
- Designed for use with both wedge (narrow) and classical V-belts
- Fine grain cast-iron 260-200
- Eccentricity of OD to bore: DIN 2211 part 1
- Groove side wobble tolerances: DIN 2211 part 1
- Surface roughness: ISO 254
- Balance quality grade: ISO 1940
- Pulley speed: Spoke – 36m/s, Solid – 38m/s



DESCRIPTION EXPLANATION

Section	Pitch Circle Diameter	x	Groove	Bush
SPB	100mm	x	2	1610

Description	Bishops Code	Description	Bishops Code
SPB 100 x 2/1610	51032100	SPB 224 x 3/2517	51033224
SPB 125 x 2/2012	51032125	SPB 250 x 2/2517	51032250
SPB 125 x 3/2012	51033125	SPB 250 x 4/3020	51034250
SPB 132 x 2/2012	51032132	SPB 280 x 3/3020	51033280
SPB 140 x 2/2012	51032140	SPB 280 x 4/3020	51034280
SPB 150 x 1/1610	51031130	SPB 300 x 2/2517	51032300
SPB 150 x 2/2012	51032150	SPB 355 x 2/3020	51032355
SPB 160 x 2/2012	51032160	SPB 355 x 3/3020	51033355
SPB 170 x 2/2012	51032170	SPB 355 x 4/3535	51034355
SPB 180 x 2/2517	51032180	SPB 400 x 2/3020	51032400
SPB 190 x 2/2517	51032190	SPB 400 x 4/3535	51034400
SPB 200 x 2/2517	51032200	-	-

POWER TRANSMISSION V-BELTS & PULLEYS

Bishops has access to a huge range of V-belts and pulleys, to help you find what you need, check out our guide below. Just find what you need and give us a call with your required size and we'll sort it out for you.

Industrial V-Belts

- Made from premium quality rubber compounds protected by an abrasion resistant fabric cover
- Fitted with low-stretch polyester reinforcing cords
- High tensile strength
- Oil and heat resistant
- Side angle: 40°
- Max. belt speed: 30m/s

'A' Section V-Belts



- Min. pulley pitch diameter: 71mm
- Top width: 13mm
- Depth: 8mm
- Weight: 110g/m
- Pitch length (Lw): 487–4,043mm

'B' Section V-Belts



- Min. pulley pitch diameter: 112mm
- Top width: 17mm
- Depth: 11mm
- Weight: 185g/m
- Pitch length (Lw): 599–13,350mm

'C' Section V-Belts



- Min. pulley pitch diameter: 112mm
- Top width: 22mm
- Depth: 14mm
- Weight: 300g/m
- Pitch length (Lw): 1,074–9,202mm

Industrial V-Belt Pulleys

- Tapered bore
- Pulleys conform to ISO 4183 and DIN 2211
- Designed for use with both wedge (narrow) and classical V-belts
- Fine grain cast iron, grade 260-200
- Eccentricity of OD to bore: DIN 2211 part 1
- Groove side wobble tolerances: DIN 2211 part 1
- Surface roughness: ISO 254
- Balance quality grade: ISO 1940
- Pulley speed: spoke – 36m/s, solid – 38m/s

SPA-A



- Suitable for 'A' section belts
- Grooves: 1–5
- Pitch circle diameter: 63–630mm
- Bush: 1,108–3,535

SPB-B-5V



- Suitable for 'B' section belts
- Grooves: 1–10
- Pitch circle diameter: 80–1,250mm
- Bush: 1,210–5,050

SPC-C



- Suitable for 'C' section belts
- Grooves: 3–8
- Pitch circle diameter: 200–1,250mm
- Bush: 2,517–5,050

These are only the most commonly sought after belts and pulleys. If you need a different style, or a particular size, just give us a call.

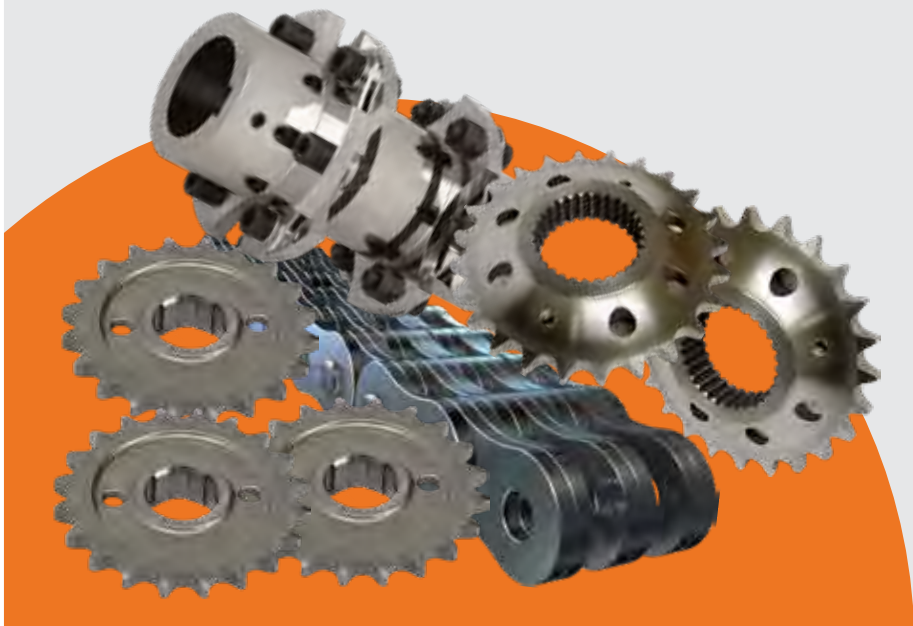

Special Orders

Bishops can supply transmission couplings, sprockets and chain. Whatever you need – Find it at Bishops!



V-BELTS

'A' INDUSTRIAL V-BELTS

- Classical
- Wrapped type, protected by an abrasion resistant fabric cover
- Made from premium quality rubber compounds
- High tensile strength
- Oil and heat resistant
- Fitted with low-stretch polyester reinforcing cords
- Provides smooth operation, shock absorption and high power transmission
- Side angle: 40°
- Max. belt speed: 30m/s
- Min. pulley pitch diameter: 71mm
- Top width: 13mm
- Depth: 8mm
- Weight: 110g/m



BEARINGS, SEALS & TRANSMISSION PRODUCTS

Item Code	Outside Length	Pitch Length	Inside Length	Bishops Code	Item Code	Outside Length	Pitch Length	Inside Length	Bishops Code	Item Code	Outside Length	Pitch Length	Inside Length	Bishops Code
A18	507mm	487mm	457mm	51210018	A50	1,320mm	1,300mm	1,270mm	51210050	A81	2,107mm	2,087mm	2,057mm	51210081
A20	558mm	538mm	508mm	51210020	A51	1,345mm	1,325mm	1,295mm	51210051	A82	2,133mm	2,113mm	2,083mm	51210082
A21	583mm	563mm	533mm	51210021	A52	1,371mm	1,351mm	1,321mm	51210052	A83	2,158mm	2,138mm	2,108mm	51210083
A22	609mm	589mm	559mm	51210022	A53	1,396mm	1,376mm	1,346mm	51210053	A84	2,184mm	2,164mm	2,134mm	51210084
A23	634mm	614mm	584mm	51210023	A54	1,422mm	1,402mm	1,372mm	51210054	A85	2,209mm	2,189mm	2,159mm	51210085
A24	660mm	640mm	610mm	51210024	A55	1,447mm	1,427mm	1,397mm	51210055	A86	2,234mm	2,214mm	2,184mm	51210086
A25	685mm	665mm	635mm	51210025	A56	1,472mm	1,452mm	1,422mm	51210056	A87	2,260mm	2,240mm	2,210mm	51210087
A26	710mm	690mm	660mm	51210026	A57	1,498mm	1,478mm	1,448mm	51210057	A88	2,285mm	2,265mm	2,235mm	51210088
A27	736mm	716mm	686mm	51210027	A58	1,523mm	1,503mm	1,473mm	51210058	A89	2,311mm	2,291mm	2,261mm	51210089
A28	761mm	741mm	711mm	51210028	A59	1,549mm	1,529mm	1,499mm	51210059	A90	2,336mm	2,316mm	2,286mm	51210090
A29	787mm	767mm	737mm	51210029	A60	1,574mm	1,554mm	1,524mm	51210060	A91	2,361mm	2,341mm	2,311mm	51210091
A30	812mm	792mm	762mm	51210030	A61	1,599mm	1,579mm	1,549mm	51210061	A92	2,387mm	2,367mm	2,337mm	51210092
A31	837mm	817mm	787mm	51210031	A62	1,625mm	1,605mm	1,575mm	51210062	A93	2,412mm	2,392mm	2,362mm	51210093
A32	863mm	843mm	813mm	51210032	A63	1,650mm	1,630mm	1,600mm	51210063	A94	2,438mm	2,418mm	2,388mm	51210094
A33	888mm	868mm	838mm	51210033	A64	1,676mm	1,656mm	1,626mm	51210064	A95	2,463mm	2,443mm	2,413mm	51210095
A34	914mm	894mm	864mm	51210034	A65	1,701mm	1,681mm	1,651mm	51210065	A96	2,488mm	2,468mm	2,438mm	51210096
A35	939mm	919mm	889mm	51210035	A66	1,726mm	1,706mm	1,676mm	51210066	A97	2,514mm	2,494mm	2,464mm	51210097
A36	964mm	944mm	914mm	51210036	A67	1,752mm	1,732mm	1,702mm	51210067	A98	2,539mm	2,519mm	2,489mm	51210098
A37	990mm	970mm	940mm	51210037	A68	1,777mm	1,757mm	1,727mm	51210068	A100	2,590mm	2,570mm	2,540mm	51210100
A38	1,015mm	995mm	965mm	51210038	A69	1,803mm	1,783mm	1,753mm	51210069	A102	2,641mm	2,621mm	2,591mm	51210102
A39	1,041mm	1,021mm	991mm	51210039	A70	1,828mm	1,808mm	1,778mm	51210070	A103	2,666mm	2,646mm	2,616mm	51210103
A40	1,066mm	1,046mm	1,016mm	51210040	A71	1,853mm	1,833mm	1,803mm	51210071	A105	2,717mm	2,697mm	2,667mm	51210105
A41	1,091mm	1,071mm	1,041mm	51210041	A72	1,879mm	1,859mm	1,829mm	51210072	A108	2,793mm	2,773mm	2,743mm	51210108
A42	1,117mm	1,097mm	1,067mm	51210042	A73	1,904mm	1,884mm	1,854mm	51210073	A110	2,844mm	2,824mm	2,794mm	51210110
A43	1,142mm	1,122mm	1,092mm	51210043	A74	1,930mm	1,910mm	1,880mm	51210074	A112	2,895mm	2,875mm	2,845mm	51210112
A44	1,168mm	1,148mm	1,118mm	51210044	A75	1,955mm	1,935mm	1,905mm	51210075	A116	2,996mm	2,976mm	2,946mm	51210116
A45	1,193mm	1,173mm	1,143mm	51210045	A76	1,980mm	1,960mm	1,930mm	51210076	A120	3,098mm	3,078mm	3,048mm	51210120
A46	1,218mm	1,198mm	1,168mm	51210046	A77	2,006mm	1,986mm	1,956mm	51210077	A124	3,200mm	3,180mm	3,150mm	51210124
A47	1,244mm	1,224mm	1,194mm	51210047	A78	2,031mm	2,011mm	1,981mm	51210078	A128	3,301mm	3,281mm	3,251mm	51210128
A48	1,269mm	1,249mm	1,219mm	51210048	A79	2,057mm	2,037mm	2,007mm	51210079	A140	3,606mm	3,586mm	3,556mm	51210140
A49	1,295mm	1,275mm	1,245mm	51210049	A80	2,082mm	2,062mm	2,032mm	51210080	-	-	-	-	-

GET MORE AT BISHOPS ▶

WORK BENCHES

Page 158



HYDRAULIC CAR HOIST

Page 389



'B' INDUSTRIAL V-BELTS

- Classical
- Wrapped type, protected by an abrasion resistant fabric cover
- Made from premium quality rubber compounds
- High tensile strength
- Oil and heat resistant
- Fitted with low-stretch polyester reinforcing cords
- Provides smooth operation, shock absorption and high power transmission

- Side angle: 40°
- Max. belt speed: 30m/s
- Min. pulley pitch diameter: 112mm
- Top width: 17mm
- Depth: 11mm
- Weight: 185g/m



Item Code	Outside Length	Pitch Length	Inside Length	Bishops Code	Item Code	Outside Length	Pitch Length	Inside Length	Bishops Code	Item Code	Outside Length	Pitch Length	Inside Length	Bishops Code
B26	730mm	700mm	660mm	51214026	B61	1,619mm	1,589mm	1,549mm	51214061	B96	2,508mm	2,478mm	2,438mm	51214096
B27	756mm	726mm	686mm	51214027	B62	1,645mm	1,615mm	1,575mm	51214062	B97	2,534mm	2,504mm	2,464mm	51214097
B28	781mm	751mm	711mm	51214028	B63	1,670mm	1,640mm	1,600mm	51214063	B98	2,559mm	2,529mm	2,489mm	51214098
B29	807mm	777mm	737mm	51214029	B64	1,696mm	1,666mm	1,626mm	51214064	B99	2,585mm	2,555mm	2,515mm	51214099
B30	832mm	802mm	762mm	51214030	B65	1,721mm	1,691mm	1,651mm	51214065	B100	2,610mm	2,580mm	2,540mm	51214100
B31	857mm	827mm	787mm	51214031	B66	1,746mm	1,716mm	1,676mm	51214066	B101	2,635mm	2,605mm	2,565mm	51214101
B32	883mm	853mm	813mm	51214032	B67	1,772mm	1,742mm	1,702mm	51214067	B102	2,661mm	2,631mm	2,591mm	51214102
B33	908mm	878mm	838mm	51214033	B68	1,797mm	1,767mm	1,727mm	51214068	B103	2,686mm	2,656mm	2,616mm	51214103
B34	934mm	904mm	864mm	51214034	B69	1,823mm	1,793mm	1,753mm	51214069	B104	2,966mm	2,936mm	2,896mm	51214104
B35	959mm	929mm	889mm	51214035	B70	1,848mm	1,818mm	1,778mm	51214070	B105	2,737mm	2,707mm	2,667mm	51214105
B36	984mm	954mm	914mm	51214036	B71	1,873mm	1,843mm	1,803mm	51214071	B106	2,762mm	2,732mm	2,692mm	51214106
B37	1,010mm	980mm	940mm	51214037	B72	1,899mm	1,869mm	1,829mm	51214072	B107	2,788mm	2,758mm	2,718mm	51214107
B38	1,035mm	1,005mm	965mm	51214038	B73	1,924mm	1,894mm	1,854mm	51214073	B108	2,813mm	2,783mm	2,743mm	51214108
B39	1,061mm	1,031mm	991mm	51214039	B74	1,950mm	1,920mm	1,880mm	51214074	B110	2,864mm	2,834mm	2,794mm	51214110
B40	1,086mm	1,056mm	1,016mm	51214040	B75	1,975mm	1,945mm	1,905mm	51214075	B111	2,889mm	2,859mm	2,819mm	51214111
B41	1,111mm	1,081mm	1,041mm	51214041	B76	2,000mm	1,970mm	1,930mm	51214076	B112	2,915mm	2,885mm	2,845mm	51214112
B42	1,137mm	1,107mm	1,067mm	51214042	B77	2,026mm	1,996mm	1,956mm	51214077	B113	2,960mm	2,930mm	2,870mm	51214113
B43	1,162mm	1,132mm	1,092mm	51214043	B78	2,051mm	2,021mm	1,981mm	51214078	B115	2,991mm	2,961mm	2,921mm	51214115
B44	1,188mm	1,158mm	1,118mm	51214044	B79	2,077mm	2,047mm	2,007mm	51214079	B116	3,016mm	2,986mm	2,946mm	51214116
B45	1,213mm	1,183mm	1,143mm	51214045	B80	2,102mm	2,072mm	2,032mm	51214080	B117	3,042mm	3,012mm	2,972mm	51214117
B46	1,238mm	1,208mm	1,168mm	51214046	B81	2,127mm	2,097mm	2,057mm	51214081	B118	3,067mm	3,037mm	2,997mm	51214118
B47	1,264mm	1,234mm	1,194mm	51214047	B82	2,153mm	2,123mm	2,083mm	51214082	B119	3,093mm	3,063mm	3,023mm	51214119
B48	1,289mm	1,259mm	1,219mm	51214048	B83	2,178mm	2,148mm	2,108mm	51214083	B120	3,118mm	3,088mm	3,048mm	51214120
B49	1,315mm	1,285mm	1,245mm	51214049	B84	2,204mm	2,174mm	2,134mm	51214084	B123	3,194mm	3,164mm	3,124mm	51214123
B50	1,340mm	1,310mm	1,270mm	51214050	B85	2,229mm	2,199mm	2,159mm	51214085	B124	3,220mm	3,190mm	3,150mm	51214124
B51	1,365mm	1,335mm	1,295mm	51214051	B86	2,254mm	2,224mm	2,184mm	51214086	B125	3,245mm	3,215mm	3,175mm	51214125
B52	1,391mm	1,361mm	1,321mm	51214052	B87	2,280mm	2,250mm	2,210mm	51214087	B127	3,296mm	3,266mm	3,226mm	51214127
B53	1,416mm	1,386mm	1,346mm	51214053	B88	2,305mm	2,275mm	2,235mm	51214088	B128	3,321mm	3,291mm	3,251mm	51214128
B54	1,442mm	1,412mm	1,372mm	51214054	B89	2,331mm	2,301mm	2,261mm	51214089	B130	3,372mm	3,342mm	3,302mm	51214130
B55	1,467mm	1,437mm	1,397mm	51214055	B90	2,356mm	2,326mm	2,286mm	51214090	B133	3,448mm	3,418mm	3,378mm	51214134
B56	1,492mm	1,462mm	1,422mm	51214056	B91	2,381mm	2,351mm	2,311mm	51214091	B134	3,474mm	3,444mm	3,404mm	51214136
B57	1,518mm	1,488mm	1,448mm	51214057	B92	2,407mm	2,377mm	2,337mm	51214092	B136	3,524mm	3,494mm	3,454mm	51214140
B58	1,543mm	1,513mm	1,473mm	51214058	B93	2,432mm	2,402mm	2,362mm	51214093	B138	3,575mm	3,545mm	3,505mm	51214144
B59	1,569mm	1,539mm	1,499mm	51214059	B94	2,458mm	2,428mm	2,388mm	51214094	B139	3,601mm	3,571mm	3,531mm	51214150
B60	1,594mm	1,564mm	1,524mm	51214060	B95	2,483mm	2,453mm	2,413mm	51214095	-	-	-	-	-

'C' INDUSTRIAL V-BELTS

- Classical
- Wrapped type, protected by an abrasion resistant fabric cover
- Made from premium quality rubber compounds
- High tensile strength
- Oil and heat resistant
- Fitted with low-stretch polyester reinforcing cords
- Provides smooth operation, shock absorption and high power transmission

- Side angle: 40°
- Max. belt speed: 30m/s
- Min. pulley pitch diameter: 112mm
- Top width: 22mm
- Depth: 14mm
- Weight: 300g/m

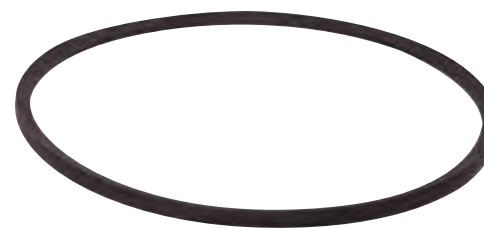

Item Code	Outside Length	Pitch Length	Inside Length	Bishops Code	Item Code	Outside Length	Pitch Length	Inside Length	Bishops Code	Item Code	Outside Length	Pitch Length	Inside Length	Bishops Code
C48	1,307mm	1,277mm	1,219mm	51218048	C82	2,171mm	2,141mm	2,083mm	51218082	C101	2,653mm	2,623mm	2,565mm	51218101
C60	1,612mm	1,582mm	1,524mm	51218060	C83	2,196mm	2,166mm	2,108mm	51218083	C103	2,704mm	2,674mm	2,616mm	51218103
C63	1,688mm	1,658mm	1,600mm	51218063	C84	2,222mm	2,192mm	2,134mm	51218084	C104	2,730mm	2,700mm	2,642mm	51218104
C64	1,714mm	1,684mm	1,626mm	51218064	C85	2,247mm	2,217mm	2,159mm	51218085	C105	2,755mm	2,725mm	2,667mm	51218105
C68	1,815mm	1,785mm	1,727mm	51218068	C86	2,272mm	2,242mm	2,184mm	51218086	C112	2,933mm	2,903mm	2,845mm	51218112
C70	1,866mm	1,836mm	1,778mm	51218070	C87	2,298mm	2,268mm	2,210mm	51218087	C115	3,009mm	2,979mm	2,921mm	51218115
C72	1,917mm	1,887mm	1,829mm	51218072	C90	2,374mm	2,344mm	2,286mm	51218090	C120	3,136mm	3,106mm	3,048mm	51218120
C74	1,968mm	1,938mm	1,880mm	51218074	C92	2,425mm	2,395mm	2,337mm	51218092	C124	3,238mm	3,208mm	3,150mm	51218124
C75	1,993mm	1,963mm	1,905mm	51218075	C93	2,450mm	2,420mm	2,362mm	51218093	C125	3,263mm	3,233mm	3,175mm	51218125
C76	2,018mm	1,988mm	1,930mm	51218076	C95	2,501mm	2,471mm	2,413mm	51218095	C136	3,542mm	3,512mm	3,454mm	51218136
C78	2,069mm	2,039mm	1,981mm	51218078	C100	2,628mm	2,598mm	2,540mm	51218100	C140	3,644mm	3,614mm	3,556mm	51218140



REFERENCE & CONVERSION FORMULAS

Conversion Formulas – Power & Force

To Convert From:	To Convert To:	Multiply By:
Horsepower (hp)	Kilowatts (kW)	0.735
Kilowatts (kW)	Horsepower (hp)	1.3597
Foot Pound (ft/lb)	Newton-Metres (Nm)	1.3558
Newton-Metres (Nm)	Foot Pound (ft/lb)	0.7376
Joule (J)	British Thermal Unit (Btu)	0.00095
British Thermal Unit (Btu)	Joule (J)	1,055.06

Conversion Formulas – Temperature

To Convert From:	To Convert To:	Formula:
Celsius (°C)	Fahrenheit (F)	$C^{\circ} = (5/9) \times (F - 32)$
Fahrenheit (F)	Celsius (°C)	$F = (9/5) \times C + 32$

Conversion Formulas – Area & Volume

To Convert From:	To Convert To:	Multiply By:
Square Inch (in ²)	Square Centimetre (cm ²)	6.452
Square Centimetre (cm ²)	Square Inch (in ²)	0.155
Cubic Feet/Minute (CFM)	Litre/Minute (L/min)	28.32
Litre/Minute (L/min)	Cubic Feet/Minute (CFM)	0.0353
Litre (L)	US Gallons (US gal)	0.26
Litre (L)	Imperial Gallons (Imp gal)	0.22
Imperial Gallons (Imp gal)	Litre (L)	4.546
US Gallons (US gal)	Litre (L)	3.785

Conversion Formulas – Pressure

• To obtain the reverse of these tables simply divide, for example: divide psi by 14.7 to obtain BAR. Divide kPa by 100 to obtain BAR

To Convert From:	To Convert To:	Multiply By:
Pound Per Square Inch (psi)	Kilopascal (kPa)	6.895
Pound Per Square Inch (psi)	Bar	0.0689
Pound Per Square Inch (psi)	Megapascal (MPa)	0.006
Kilopascal (kPa)	Pound Per Square Inch (psi)	0.1453
Kilopascal (kPa)	Bar	0.01
Bar	Pound Per Square Inch (psi)	14.70
Bar	Kilopascal (kPa)	100
Kilogram Square Centimetre (KGF/CM ²)	Pound Per Square Inch (psi)	14.23
Kilogram Square Centimetre (KGF/CM ²)	Bar	0.981

See our Reference Section on page 523 for more handy technical information.

SIMPLEX ROLLER CHAIN

- Length: 10ft



Item Code	Pitch	Bishops Code
06B-1	3/8"	50610006
08B-1	1/2"	50610008
10B-1	5/8"	50610010
12B-1	3/4"	50610012
16B-1	1"	50610016

TECO MAXE3 PREMIUM SEVERE DUTY ELECTRIC MOTORS

- High efficiency motors
- Cast iron frame
- Class F insulation system
- IP66 rated
- Single phase
- Ambient temperatures up to 55°C



Item Code	Output	Speed	Bishops Code
132/01.5ME4	1.5kW	1,500rpm	77510500
132/02.2ME4	2.2kW	1,500rpm	77510505
132/02.2ME2	2.2kW	2,850rpm	77510525

TECO MAX E3 HEAVY DUTY ELECTRIC MOTORS

- High efficiency motors
- Cast iron frame
- Class F insulation system
- IP66 rated
- Ambient temperatures up to 40°C



Item Code	Output	Speed	Frame	Bishops Code
2 POLE				
002/01.5D2S	1.5kW	2,820rpm	90S	77510600
002/02.2D2S	2.2kW	2,845rpm	90L	77510605
003/0003D2S	3.0kW	2,845rpm	1000L	77510610
003/0004D2S	4.0kW	2,865rpm	112M	77510615
003/0005D2S	5.5kW	2,905rpm	132S	77510620
003/0007D2S	7.5kW	2,905rpm	132S	77510625
004/0011D2S	11.kW	2,940rpm	160M	77510630
004/0015D2S	15.kW	2,925rpm	160M	77510635
004/0018D2S	18.5kW	2,925rpm	160L	77510640
004/0022D2S	22.kW	2,925rpm	180MA	77510645
005/0030D2R	30.kW	2,960rpm	200LA	77510650
005/0037D2S	37.kW	2,955rpm	200LA	77510655
4 POLE				
001/0.37D4S	0.37kW	1,405rpm	80	77510690
002/0.75D4S	0.75kW	1,405rpm	80	77510700
002/01.1D4S	1.1kW	1,410rpm	90S	77510705
002/01.5D4S	1.5kW	1,395rpm	90L	77510710
002/02.2D4S	2.2kW	1,425rpm	100L	77510715
003/0003D4S	3.0kW	1,430rpm	100L	77510720
003/0004D4S	4.0kW	1,440rpm	112M	77510725
003/0005D4S	5.5kW	1,445rpm	132S	77510730
003/0007D4S	7.5kW	1,445rpm	132M	77510735
004/0011D4S	11.kW	1,465rpm	160M	77510740
004/0015D4S	15.kW	1,460rpm	160L	77510742
004/0018D4S	18.5kW	1,460rpm	180M	77510745
004/0022D4S	22.kW	1,460rpm	180LC	77510750
005/0030D4S	30.kW	1,470rpm	200LC	77510755
005/0037D4S	37.kW	1,465rpm	225SC	77510760
6 POLE				
001/0.37D6S	0.37kW	935rpm	90S	77510790
002/01.1D6S	1.1kW	935rpm	90S	77510800
002/01.5D6S	1.5kW	940rpm	90L	77510805
002/02.2D6S	2.2kW	950rpm	112M	77510810
003/0003D6S	3.0kW	950rpm	132M	77510815
003/0007D6S	7.5kW	976rpm	160M	77510830

GET MORE AT BISHOPS ▶



AIR COMPRESSORS

From Page 327



O-RINGS, CIRCLIPS & E-CLIPS GRAB KITS

BEARINGS, SEALS & TRANSMISSION PRODUCTS

O-RING KITS – METRIC & IMPERIAL

- Nitrile
- 70 shore



CA115

Item Code	Description	Kit Size	Bishops Code
CA115	Imperial – 14 Sizes: 3/16"–1" ID	115 Pieces	40410180
CA116	Metric – 15 Sizes: 5–25mm ID	130 Pieces	40410190
CA407	Imperial – 32 Sizes: 1/8"–2" ID	407 Pieces	40410450
CA408	Metric – 32 Sizes: 3–50mm ID	408 Pieces	40410460

O-RING GRAB KITS – METRIC & IMPERIAL



Description	Bishops Code
386 Piece Metric Grab Kit – Includes 3 to 44mm ID	29002100
450 Piece Imperial Grab Kit – Includes 3/8" to 1 3/4" ID	29202100

SPLICING "O" RING CORD KIT – METRIC

- Nitrile
- 70 shore
- 9 sizes: 1.5 to 8.5mm
- 900mm long



Item Code	Bishops Code
CA410	40410470



155 PIECE INTERNAL & EXTERNAL CIRCLIP KITS – METRIC & IMPERIAL



CA1760

Item Code	Description	Kit Size	Bishops Code
CA155	Imperial – 14 Sizes: 1/4"–1"	155 Pieces	40410260
CA1760	Metric – 14 Sizes: 6–25mm	155 Pieces	40410830

360 PIECE INTERNAL & EXTERNAL CIRCLIP KITS – METRIC

- Comes in hard plastic case for handy storage



Description	Bishops Code
360 Piece External Circlip Kit – Includes Sizes 6 to 50mm	40420050
360 Piece Internal Circlip Kit – Includes Sizes 10 to 52mm	40420051

740 PIECE E CLIPS & RETAINER SPRINGS KIT – IMPERIAL



Includes:

- 14 sizes:
- E Clips: 3/32"–5/8" shaft sizes
- Retainer Springs: 11/64"–17/32" shaft sizes



Item Code	Bishops Code
CA1424	40410730

300 PIECE E-CLIP GRAB KIT – METRIC

- Comes in hard plastic case for handy storage

Includes:

- 9 sizes – 1.5 to 22mm



Item Code	Bishops Code
FD-6005	40420053

GET MORE AT BISHOPS ▶



CIRCLIP PLIERS

Page 203

METRIC KEY STEEL

- Zinc plated
- Length: 300mm



Size	Bishops Code	Size	Bishops Code
4 x 4mm	51420004	12 x 12mm	51420012
5 x 5mm	51420005	14 x 14mm	51420014
6 x 6mm	51420006	16 x 16mm	51420016
8 x 8mm	51420008	18 x 18mm	51420018
10 x 10mm	51420010	20 x 20mm	51420020

IMPERIAL KEY STEEL

- Zinc plated
- Comes in 12" or 12 1/4" lengths



Size	Bishops Code	Size	Bishops Code
12" LENGTH			
3/8" x 3/8"	51410012	3/8" x 3/8"	51410037
3/16" x 3/16"	51410018	7/16" x 7/16"	51410043
1/4" x 1/4"	51410025	1/2" x 1/2"	51410050
5/16" x 5/16"	51410031	-	-
12 1/4" LENGTH			
5/8" x 5/8"	51410062	1 1/4" x 1 1/4"	51410125
3/4" x 3/4"	51410075	1 1/2" x 1 1/2"	51410150

80 PIECE WOODRUFF KEY GRAB KIT – METRIC

- Comes in hard plastic case for handy storage
- Includes:**
- 8 Sizes – 3 x 5 x 13mm to 9 x 22mm



Item Code	Bishops Code
FD-6049	40420076

60 PIECE MACHINERY KEY GRAB KITS – METRIC & IMPERIAL

- Comes in hard plastic case for handy storage



Description	Bishops Code
Metric Machinery Key Kit – 13 Sizes: 3 x 20mm to 12 x 40mm	40420057
Imperial Machinery Key Kit – 13 Sizes: 1/4" x 3/4" to 1/4" x 1 1/4"	40420058

GET MORE AT BISHOPS



MECHANIC'S GLOVES

Page 7

BRASS SHIM

- Ideal for filling small gaps and spaces
- Provides excellent corrosion resistance around water, fuel, oil, gasoline, kerosene and alcohol
- Thickness: 0.08mm
- Width: 150mm
- Length: 3m



Bishops Code
67082340

SHIM STOCK SHEETS

- 4 Sizes: 0.002" to 0.010" thickness
- 150 x 150mm sheets
- 6 sheets per pack



Item Code	Description	Bishops Code
CA32	Brass	67082040
CA34	Steel	67084040

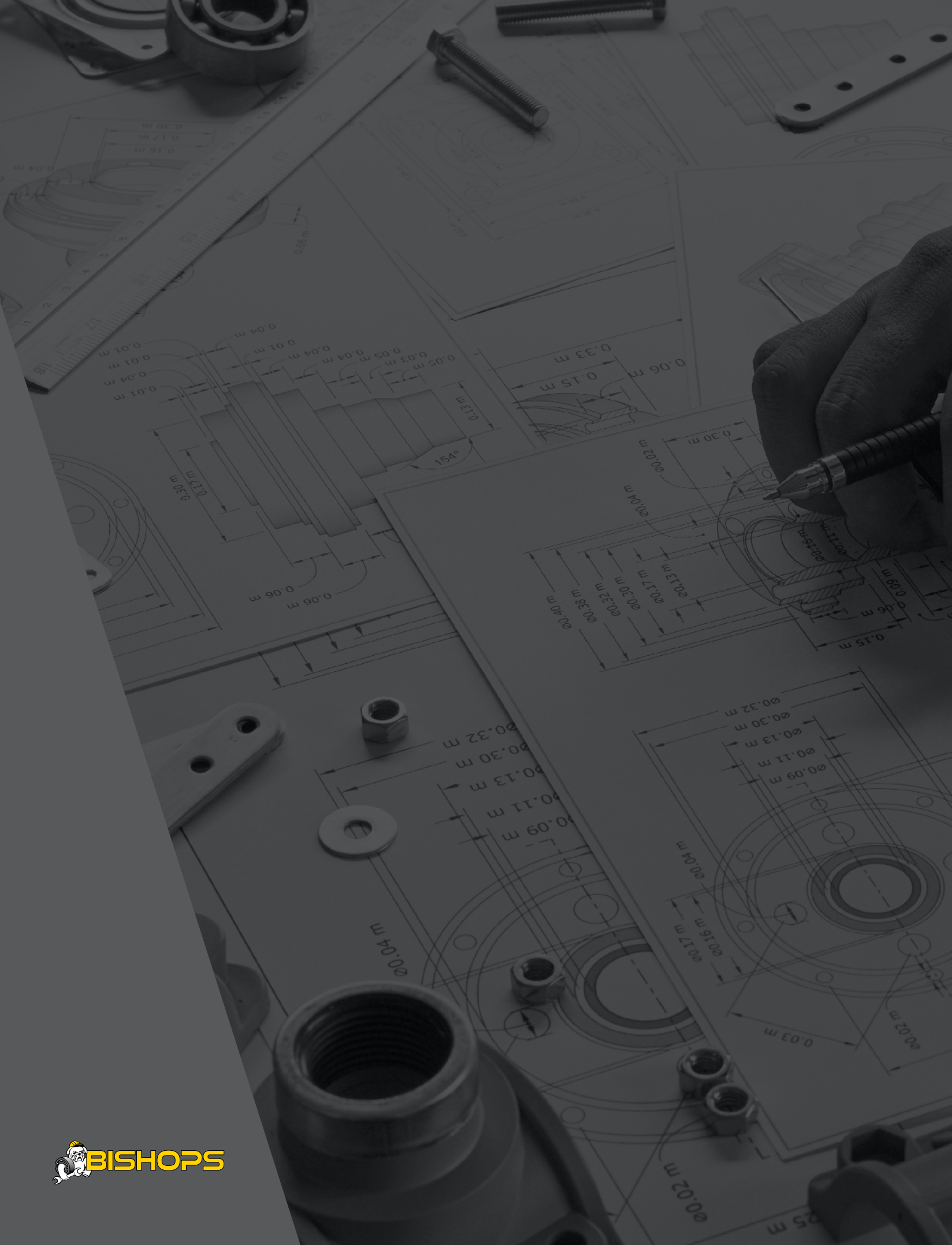

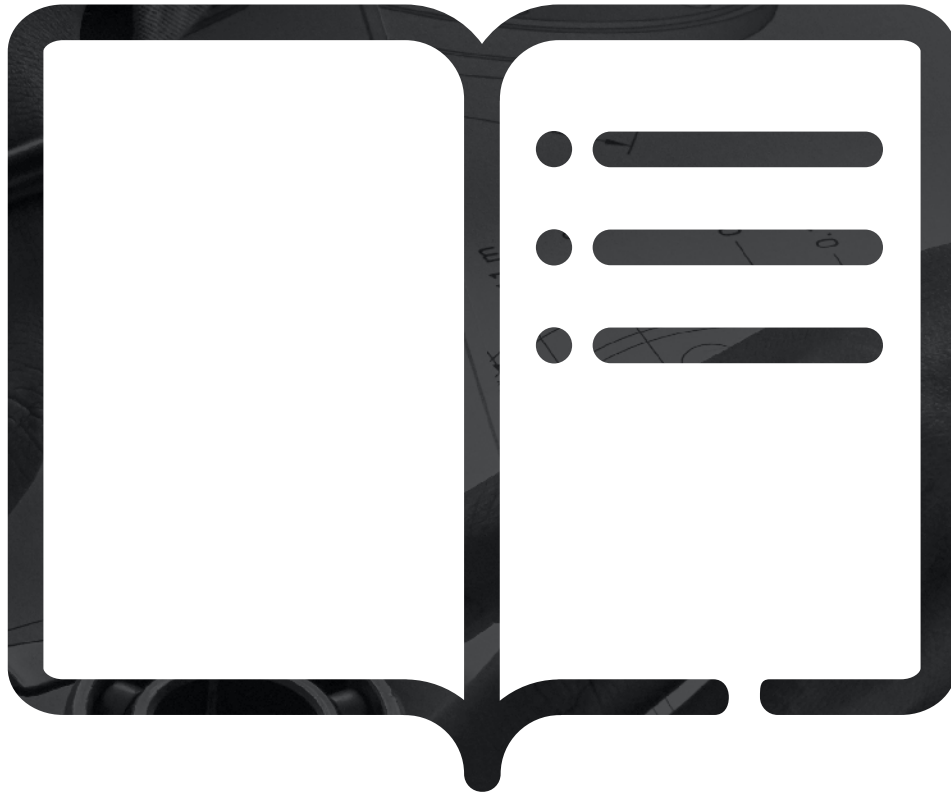

14

REFERENCE CHARTS & INFORMATION

Power & Force	524	Tapping Drill Sizes	528–530
Gauge	524	Wire Gauge	530
Temperature	525	British Standard Threads.....	531
Area & Volume.....	525	Pipe Specifications.....	532–533
Length, Size & Mass	526	Flange Specifications.....	533–534
Pitch & Thread.....	527	Bolt & Nut Specifications.....	534
Pressure	528		



LENGTH, SIZE & MASS

LENGTH & SIZE

To Convert From:	To Convert To:	Multiply By:	To Convert From:	To Convert To:	Multiply By:
Inches (")	Millimetres (mm)	25.4	Miles (M)	Metres (m)	1,609.3
Inches (")	Centimetres (cm)	2.54	Miles (M)	Kilometres (km)	1.609
Millimetres (mm)	Inches (")	0.039	Kilometres (km)	Miles (M)	0.621
Centimetres (cm)	Inches (")	0.394	Microns (µm)	Millimetres (mm)	0.001
Feet (ft)	Metres (m)	0.3048	Millimetres (mm)	Microns (µm)	1,000
Metres (m)	Feet (ft)	3.28	-	-	-

IMPERIAL INCH & METRIC COMPARISON CHART

Imperial	Inch	Nearest mm	Difference	Imperial	Inch	Nearest mm	Difference	Imperial	Inch	Nearest mm	Difference
1/32"	0.0313"	1mm	0.08"	1 1/32"	1.0313"	26mm	-0.08"	2 1/32"	2.0313"	52mm	0.16"
1/16"	0.0625"	2mm	0.16"	1 1/16"	1.0625"	27mm	0.00"	2 1/16"	2.0625"	52mm	-0.15"
5/64"	0.0781"	2mm	0.01"	1 5/64"	1.0781"	27mm	-0.15"	2 5/64"	2.0781"	53mm	0.08"
3/32"	0.0938"	2mm	-0.15"	1 3/32"	1.0938"	28mm	0.09"	2 3/32"	2.0938"	53mm	-0.07"
1/8"	0.125"	3mm	-0.07"	1 1/8"	1.125"	29mm	0.17"	2 1/8"	2.125"	54mm	0.01"
5/32"	0.1563"	4mm	0.01"	1 5/32"	1.1563"	29mm	-0.15"	2 5/32"	2.1563"	55mm	0.09"
3/16"	0.1875"	5mm	0.09"	1 3/16"	1.1875"	30mm	-0.06"	2 3/16"	2.1875"	56mm	0.17"
13/64"	0.2031"	5mm	-0.06"	1 13/64"	1.2031"	31mm	0.17"	2 13/64"	2.2031"	56mm	0.02"
7/32"	0.2188"	6mm	0.17"	1 7/32"	1.2188"	31mm	0.02"	2 7/32"	2.2188"	56mm	-0.14"
1/4"	0.25"	6mm	-0.14"	1 1/4"	1.25"	32mm	0.10"	2 1/4"	2.25"	57mm	-0.06"
9/32"	0.2813"	7mm	-0.06"	1 9/32"	1.2813"	33mm	0.18"	2 9/32"	2.2813"	58mm	0.02"
5/16"	0.3125"	8mm	0.02"	1 5/16"	1.3125"	33mm	-0.13"	2 5/16"	2.3125"	59mm	0.10"
21/64"	0.3281"	8mm	-0.13"	1 21/64"	1.3281"	34mm	0.10"	2 21/64"	2.3281"	59mm	-0.05"
11/32"	0.3438"	9mm	0.11"	1 11/32"	1.3438"	34mm	-0.05"	2 11/32"	2.3438"	60mm	0.18"
3/8"	0.375"	10mm	0.19"	1 3/8"	1.375"	35mm	0.03"	2 3/8"	2.375"	60mm	-0.13"
13/32"	0.4063"	10mm	-0.13"	1 13/32"	1.4063"	36mm	0.11"	2 13/32"	2.4063"	61mm	-0.05"
7/16"	0.4375"	11mm	-0.04"	1 7/16"	1.4375"	37mm	0.19"	2 7/16"	2.4375"	62mm	0.03"
29/64"	0.4531"	12mm	0.19"	1 29/64"	1.4531"	37mm	0.04"	2 29/64"	2.4531"	62mm	-0.12"
15/32"	0.4688"	12mm	0.04"	1 15/32"	1.4688"	37mm	-0.12"	2 15/32"	2.4688"	63mm	0.12"
1/2"	0.5"	13mm	0.12"	1 1/2"	1.5"	38mm	-0.04"	2 1/2"	2.5"	64mm	0.20"
17/32"	0.5313"	13mm	-0.19"	1 17/32"	1.5313"	39mm	0.04"	2 17/32"	2.5313"	64mm	-0.12"
9/16"	0.5625"	14mm	-0.11"	1 9/16"	1.5625"	40mm	0.12"	2 9/16"	2.5625"	65mm	-0.03"
37/64"	0.5781"	15mm	0.12"	1 37/64"	1.5781"	40mm	-0.03"	2 37/64"	2.5781"	65mm	-0.19"
19/32"	0.5938"	15mm	-0.03"	1 19/32"	1.5938"	40mm	-0.19"	2 19/32"	2.5938"	66mm	0.05"
5/8"	0.625"	16mm	0.05"	1 5/8"	1.625"	41mm	-0.11"	2 5/8"	2.625"	67mm	0.13"
21/32"	0.6563"	17mm	0.13"	1 21/32"	1.6563"	42mm	-0.03"	2 21/32"	2.6563"	67mm	-0.18"
11/16"	0.6875"	17mm	-0.18"	1 11/16"	1.6875"	43mm	0.05"	2 11/16"	2.6875"	68mm	-0.10"
45/64"	0.7031"	18mm	0.06"	1 45/64"	1.7031"	43mm	-0.10"	2 45/64"	2.7031"	69mm	0.13"
23/32"	0.7188"	18mm	-0.10"	1 23/32"	1.7188"	44mm	0.14"	2 23/32"	2.7188"	69mm	-0.02"
3/4"	0.75"	19mm	-0.02"	1 3/4"	1.75"	44mm	-0.18"	2 3/4"	2.75"	70mm	0.06"
25/32"	0.7813"	20mm	0.06"	1 25/32"	1.7813"	45mm	-0.10"	2 25/32"	2.7813"	71mm	0.14"
13/16"	0.8125"	21mm	0.14"	1 13/16"	1.8125"	46mm	-0.01"	2 13/16"	2.8125"	71mm	-0.17"
53/64"	0.8281"	21mm	-0.01"	1 53/64"	1.8281"	46mm	-0.17"	2 53/64"	2.8281"	72mm	0.07"
27/32"	0.8438"	21mm	-0.17"	1 27/32"	1.8438"	47mm	0.07"	2 27/32"	2.8438"	72mm	-0.09"
7/8"	0.875"	22mm	-0.09"	1 7/8"	1.875"	48mm	0.15"	2 7/8"	2.875"	73mm	-0.01"
29/32"	0.9063"	23mm	-0.01"	1 29/32"	1.9063"	48mm	-0.16"	2 29/32"	2.9063"	74mm	0.07"
15/16"	0.9375"	24mm	0.07"	1 15/16"	1.9375"	49mm	-0.08"	2 15/16"	2.9375"	75mm	0.15"
61/64"	0.9531"	24mm	-0.08"	1 61/64"	1.9531"	50mm	0.15"	2 61/64"	2.9531"	75mm	-0.00"
31/32"	0.9688"	25mm	0.15"	1 31/32"	1.9688"	50mm	-0.00"	2 31/32"	2.9688"	75mm	-0.16"
63/64"	0.9844"	25mm	-0.00"	1 63/64"	1.9844"	50mm	-0.16"	2 63/64"	2.9844"	76mm	0.08"
1"	1"	25mm	-0.16"	2"	2"	51mm	0.08"	3"	3"	76mm	-0.08"

MASS

To Convert From:	To Convert To:	Multiply By:
Pounds (lb)	Kilograms (kg)	0.4536
Kilograms (kg)	Pounds (lb)	2.205
Ounces (oz.)	Kilograms (kg)	0.0283
Kilograms (kg)	Ounces (oz.)	35.274
Stone (st)	Kilograms (kg)	6.35
Kilograms (kg)	Stone (st)	0.1575
Tonne (t)	US Ton	1.102
Tonne (t)	Imperial Ton	0.984
US Ton	Tonne (t)	0.907
Imperial Ton	Tonne (t)	1.016

POUND TO KILOGRAM CONVERSION TABLE

Pounds	Kilograms	Pounds	Kilograms	Pounds	Kilograms
0.1lb	0.05kg	6.0lb	2.72kg	24lb	10.89kg
0.2lb	0.09kg	7.0lb	3.18kg	26lb	11.79kg
0.3lb	0.14kg	8.0lb	3.63kg	28lb	12.70kg
0.4lb	0.18kg	9.0lb	4.08kg	30lb	13.61kg
0.5lb	0.23kg	10lb	4.54kg	35lb	15.88kg
0.6lb	0.27kg	11lb	4.99kg	40lb	18.14kg
0.7lb	0.32kg	12lb	5.44kg	45lb	20.41kg
0.8lb	0.36kg	13lb	5.90kg	50lb	22.68kg
0.9lb	0.41kg	14lb	6.35kg	55lb	24.95kg
1.0lb	0.45kg	15lb	6.80kg	60lb	27.22kg
1.5lb	0.68kg	16lb	7.26kg	65lb	29.48kg
2.0lb	0.91kg	17lb	7.71kg	70lb	31.75kg
2.5lb	1.13kg	18lb	8.16kg	75lb	34.02kg
3.0lb	1.36kg	19lb	8.62kg	80lb	36.29kg
4.0lb	1.81kg	20lb	9.07kg	90lb	40.82kg
5.0lb	2.27kg	22lb	9.98kg	100lb	45.36kg



PRESSURE & TAPPING DRILL SIZES

PRESSURE

To Convert From:	To Convert To:	Multiply By:
Pounds Per Square Inch (psi)	Kilopascal (kPa)	6.895
Pounds Per Square Inch (psi)	Bar	0.0689
Pounds Per Square Inch (psi)	Megapascal (MPa)	0.006895
Kilopascal (kPa)	Pounds Per Square Inch (psi)	0.1453
Kilopascal (kPa)	Bar	0.01
Bar	Pounds Per Square Inch (psi)	14.7
Bar	Kilopascal (kPa)	100
Kilogram Square Centimetre (KGF/CM ²)	Pounds Per Square Inch (psi)	14.23
Kilogram Square Centimetre (KGF/CM ²)	Bar	0.981

To obtain the reverse of these tables simply divide. For example divide psi by 14.7 to obtain Bar. Divide kPa by 100 to obtain Bar

KPA PRESSURE CONVERSION CHART

kPa	psi	Bar	kPa	psi	Bar
1	0.145	0.01	2,500	362.5	25
10	1.45	0.1	2,600	377	26
100	14.5	1	3,000	435	30
500	72.5	5	3,500	507.5	35
1,000	145	10	4,000	580	40
1,100	159.5	11	4,500	652.5	45
1,200	174	12	5,000	725	50
1,300	188.5	13	10,000	1,450	100
1,400	203	14	20,000	2,900	200
1,500	217.5	15	50,000	7,250	500
1,600	232	16	100,000	14,500	1,000
1,700	246.5	17	150,000	21,750	1,500
1,800	261	18	200,000	29,000	2,000
1,900	275.5	19	250,000	36,250	2,500
2,000	290	20	300,000	43,500	3,000

PSI PRESSURE CONVERSION CHART

psi	kPa	Bar	MPa	psi	kPa	Bar	MPa
1	6.90	0.07	0.01	125	861.88	8.61	0.86
2	13.79	0.14	0.01	130	896.35	8.96	0.90
3	20.69	0.21	0.02	145	999.78	9.99	1.00
4	27.58	0.28	0.03	150	1,034.25	10.34	1.03
5	34.48	0.34	0.03	160	1,103.20	11.02	1.10
10	68.95	0.69	0.07	190	1,310.05	13.09	1.31
15	103.43	1.03	0.10	200	1,379.00	13.78	1.38
20	137.90	1.38	0.14	210	1,447.95	14.47	1.45
30	206.85	2.07	0.21	220	1,516.90	15.16	1.52
50	344.75	3.45	0.34	230	1,585.85	15.85	1.59
60	413.70	4.13	0.41	250	1,723.75	17.23	1.72
70	482.65	4.82	0.48	500	3,447.50	34.45	3.45
80	551.60	5.51	0.55	750	5,171.07	51.71	5.17
90	620.55	6.20	0.62	1,000	6,895.00	68.90	6.90
100	689.50	6.89	0.69	5,000	34,475.50	344.50	34.48
115	792.93	7.92	0.79	10,000	68,950.00	689.00	68.95

TAPPING DRILL SIZES

All sizes are "suggested sizes" only and may be varied to suit individual requirements

METRIC

Metric Coarse (60°)					
Tap Size	Pitch	Tapping Drill	Tap Size	Pitch	Tapping Drill
M1.6	0.35mm	1.25mm	M18	2.5mm	15.5mm
M2	0.4mm	1.6mm	M20	2.5mm	17.5mm
M2.5	0.45mm	2.05mm	M22	2.5mm	19.5mm
M3	0.5mm	2.5mm	M24	3.0mm	21.0mm
M3.5	0.6mm	2.9mm	M27	3.0mm	24.0mm
M4	0.7mm	3.3mm	M30	3.5mm	26.5mm
M4.5	0.75mm	3.7mm	M33	3.5mm	29.5mm
M5	0.8mm	4.2mm	M36	4.0mm	32.0mm
M6	1.0mm	5.0mm	M42	4.5mm	37.5mm
M8	1.25mm	6.8mm	M45	4.5mm	40.5mm
M10	1.5mm	8.5mm	M48	5.0mm	43.0mm
M12	1.75mm	10.2mm	M52	5.0mm	47.0mm
M14	2.0mm	12.0mm	M56	5.5mm	50.5mm
M16	2.0mm	14.0mm	-	-	-

The tapping drill sizes indicated are recommended only and should give approximately 75% of thread depth

METRIC FINE

ISO Metric Coarse (60°)					
Tap Size	Pitch	Tapping Drill	Tap Size	Pitch	Tapping Drill
M4	0.5mm	3.5mm	M20*	1.5mm	18.5mm
M5	0.5mm	4.5mm	M22	1.5mm	20.5mm
M6	0.8mm	5.3mm	M24	2.0mm	22.0mm
M8	1.0mm	7.0mm	M25*	1.5mm	23.5mm
M10	1.25mm	8.8mm	M32*	1.5mm	30.5mm
M12	1.5mm	10.5mm	M40*	1.5mm	38.5mm
M14	1.5mm	12.5mm	M50*	1.5mm	48.5mm
M16*	1.5mm	14.5mm	-	-	-

Metric Fine - Spark Plug

M10	1.0mm	9.0mm	M14	1.25mm	12.8mm
M12	1.25mm	10.8mm	M18	1.50mm	16.5mm

* Metric Conduit

8UN (8TPI)

Unified National Form (60°)					
Tap Size	tpi	Tapping Drill	Tap Size	tpi	Tapping Drill
1 1/8"	8	25.5mm	1 1/8"	8	38mm
1 1/4"	8	28.5mm	1 3/4"	8	41.5mm
1 3/8"	8	31.75mm	1 7/8"	8	44.5mm
1 1/2"	8	35mm	2"	8	47.5mm

UNC

Unified National Coarse (60°)					
Tap Size	tpi	Tapping Drill	Tap Size	tpi	Tapping Drill
#2 (0.086)	56	1.85mm	1/2"	13	10.8mm
#3 (0.099)	48	2.1mm	9/16"	12	12.2mm
#4 (0.112)	40	2.25mm	5/8"	11	13.5mm
#5 (0.125)	40	2.60mm	3/4"	10	16.5mm
#6 (0.138)	32	2.75mm	7/8"	9	19.5mm
#8 (0.164)	32	3.4mm	1"	8	22.0mm
#10 (0.190)	24	3.8mm	1 1/8"	7	25.0mm
#12 (0.216)	24	4.5mm	1 1/4"	7	28.0mm
1/4"	20	5.1mm	1 3/8"	6	31.0mm
5/16"	18	6.6mm	1 1/2"	6	34.0mm
3/8"	16	8.0mm	1 3/4"	5	39.5mm
7/16"	14	9.4mm	2"	4.5	45mm

Pg

Steel Conduit (80°)					
Tap Size	tpi	Tapping Drill	Tap Size	tpi	Tapping Drill
Pg7	20	11.3mm	Pg13.5	18	19.1mm
Pg9	18	13.9mm	Pg16	18	21.2mm
Pg11	18	17.3mm	Pg21	15	26.8mm

GET MORE AT BISHOPS



PRESSURE GAUGES

Page 502

MATERIAL SPECIFICATIONS – BRITISH STANDARD THREADS (BST)

• This thread needs a gasket or seal to be gas/liquid tight

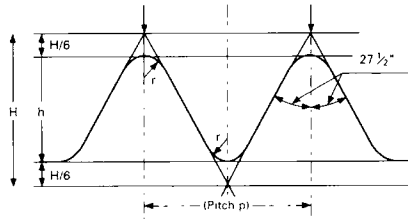
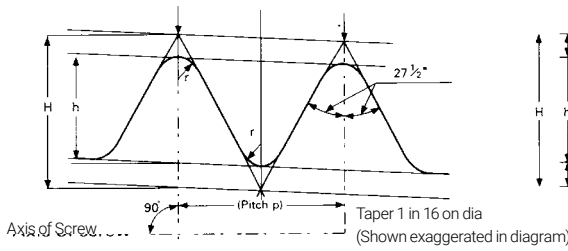

TAPER	
Legend	
H	0.960237 x p
h	0.640327 x p
r	0.137278 x p
p	Pitch

CHEMICAL COMPOSITION OF SEAMLESS STEEL FITTINGS		
C max. (%)	S max. (%)	P max. (%)
0.25	0.35	0.09

CHEMICAL COMPOSITION OF FABRICATED FITTINGS			
C max. (%)	Mn max. (%)	P max. (%)	S max. (%)
0.25	1.40	0.05	0.045

MECHANICAL PROPERTIES OF SEAMLESS STEEL FITTINGS	
Tensile Strength Min. (N/mm ²)	Elongation Min. (%)
320	20

MECHANICAL PROPERTIES OF FABRICATED FITTINGS		
Tensile Strength Min. (N/mm ²)	Yields Strength Min. (N/mm ²)	Elongation Min. (%)
320	195	20

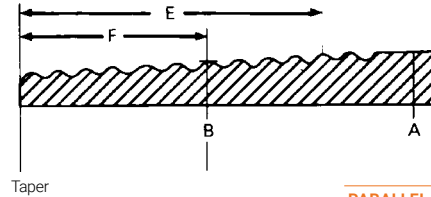

PARALLEL	
Legend	
H	0.960491 x p
h	0.640327 x p
r	0.137329 x p
p	Pitch

NOMINAL BORE OF PIPE		Approx. Outside (A)	No. of Threads Per Inch	Pitch (P)	Depth of Threads (h)	Dia. at Gauge Plane (B)	Length of Useful Thread (E)
Imperial	Metric						
1/8"	M6	10.16mm	28	0.907mm	0.582mm	9.72mm	6.46mm
1/4"	M8	13.66mm	19	1.337mm	0.856mm	13.15mm	9.68mm
3/8"	M10	17.17mm	19	1.337mm	0.856mm	16.66mm	10.02mm
1/2"	M15	21.51mm	14	1.815mm	1.161mm	20.95mm	13.15mm
3/4"	M20	27.00mm	14	1.815mm	1.161mm	26.44mm	14.51mm
1"	M25	33.93mm	11	2.310mm	1.479mm	33.24mm	16.74mm
1 1/4"	M32	42.59mm	11	2.310mm	1.479mm	41.91mm	19.05mm
1 1/2"	M40	48.48mm	11	2.310mm	1.479mm	46.27mm	19.05mm
2"	M50	60.47mm	11	2.310mm	1.479mm	59.61mm	23.37mm
2 1/2"	M65	76.09mm	11	2.310mm	1.479mm	75.18mm	26.69mm
3"	M80	88.87mm	11	2.310mm	1.479mm	87.88mm	29.87mm
4"	M100	114.14mm	11	2.310mm	1.479mm	113.03mm	35.79mm
5"	M125	139.65mm	11	2.310mm	1.479mm	138.43mm	40.12mm
6"	M150	165.12mm	11	2.310mm	1.479mm	163.83mm	40.12mm

MECHANICAL PROPERTIES OF ALLOY STUD BOLTS TO BC 1750

B7	B7A	B14	B16	L7
LIMITED RULING SECTION				
2 1/2"	2 1/2"– 4"	2 1/2"	2 1/2"– 4"	2 1/2"
MINIMUM TENSILE STRENGTH				
123,000lb	112,000in ²	123,000lb	112,000in ²	123,000lb
86.6kg	78.7mm ²	86.6kg	78.7mm ²	86.6kg
55t	50in ²	55t	50in ²	55t
MINIMUM YIELD STRESS				
103,000lb	94,000in ²	103,000lb	94,000in ²	103,000lb
72.4kg	66.1mm ²	72.4kg	66.1mm ²	72.4kg
46t	42in ²	46t	42in ²	46t
MAXIMUM ELONGATION				
18%	20%	18%	20%	18%

IMPACT PROPERTIES

B7	B7A	B14	B16	L7
MINIMUM IZOD IMPACT VALUE				
40ft/lb	40ft/lb	35ft/lb	35ft/lb	–
Charpy V-Notch Low-Temperature Impact Value at -150°F				15ft/lb at -100°C
MINIMUM TEMPERING TEMPERATURE				
600°C (1,100°F)		650°C (1,200°F)	650°C (1,200°F)	650°C (1,200°F)

The minimum tempering temperatures have been set at a suitable margin above the maximum temperature to which these grades of material are normally limited in service.



PIPE SPECIFICATIONS

MATERIAL SPECIFICATIONS – TYPE OF MATERIAL FOR FORGED FITTINGS

Mechanical Properties						
ASTM	Symbol	Grade	Tens. Str. kg/mm ²	Yield P. kg/mm ²	Elong. 2" 5D	% Red. of area
A-105	A-105-81	C.STEEL	48.5	25.0	22.0	30.0
A-182	F-11	1.25% Cr. – 0.5% Molybdenum	48.5	27.5	20.0	30.0
A-182	F-22	2.25% Cr. – 1% Molybdenum	51.5	31.0	20.0	30.0
A-182	F-5	5% Cr. – 0.5% Molybdenum	48.5	27.5	20.0	35.0
A-182	F-304	18% Cr. – 8% Nickel	51.5	20.5	30.0	50.0
A-182	F-304L	18% Cr. – 8% Nickel (C = 0.035% max.)	48.5	17.0	30.0	50.0
A-182	F-316	18% Cr. – 10% Nickel 2% Molybdenum	51.5	20.5	30.0	50.0
A-182	F-316L	18% Cr. – 10% Nickel 2% Molybdenum	48.5	17.0	30.0	50.0
A-350	LF-2	(C = 0.035% max.) CARBON STEEL or Low Temp. Services	48.3	24.8	22.0	30.0

STANDARD TAPER PIPE THREAD (NPT) – USAS B2.1

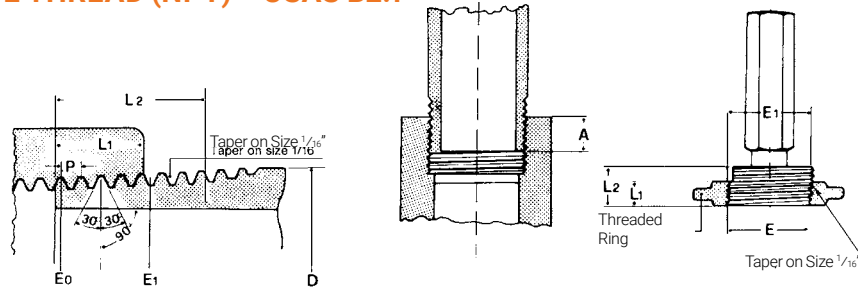

Legend	Pipe Size												
	1/8"	1/4"	3/8"	1/2"	3/4"	1"	1 1/4"	1 1/2"	2"	2 1/2"	3"	4"	
D	10.29mm	13.72mm	17.14mm	21.34mm	26.67mm	33.40mm	42.16mm	48.26mm	60.32mm	73.02mm	88.90mm	114.30mm	
n	27	18	18	14	14	11 1/2	11 1/2	11 1/2	11 1/2	8	8	8	
P	0.940mm	1.411mm	1.411mm	1.814mm	1.814mm	2.209mm	2.209mm	2.209mm	2.109mm	3.175mm	3.175mm	3.175mm	
E0	9.233mm	12.126mm	15.545mm	19.264mm	24.579mm	30.826mm	39.551mm	45.621mm	57.633mm	69.076mm	84.852mm	110.093mm	
E1	9.489mm	12.487mm	15.926mm	19.772mm	25.117mm	31.461mm	40.218mm	46.287mm	58.325mm	70.159mm	86.068mm	111.433mm	
L2	6.703mm	10.205mm	10.358mm	13.556mm	13.860mm	17.343mm	17.952mm	18.377mm	19.215mm	28.892mm	30.480mm	33.020mm	
L1	4.102mm	5.786mm	6.096mm	8.128mm	8.610mm	10.160mm	10.668mm	10.668mm	11.074mm	17.322mm	19.456mm	21.437mm	
mm	0.0586mm	0.0881mm	0.0881mm	0.1132mm	0.1132mm	0.1379mm	0.1379mm	0.1379mm	0.1379mm	0.1982mm	0.1983mm	0.1983mm	
A	6.9mm	10mm	10.3mm	13.6mm	14.1mm	16.8mm	17.3mm	17.3mm	17.7mm	23.7mm	25.8mm	27.8mm	

STANDARD TAPER PIPE THREAD (NPT) – UNI 339-66

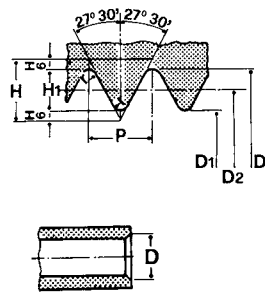

Cylindrical Inside Thread

Nominal Dimensions

Legend	
P	25.4/z
H	0.960491 P
H1	0.640327 P
r	0.137329 P

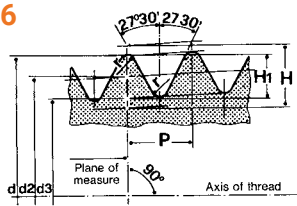

Legend

P	25.4/z
H	0.960 237 P
H1	0.640 327 P
r	0.137 278 P
Taper	1:16

Legend	Description	Pipe Size															
		1/8"	1/4"	3/8"	1/2"	3/4"	1"	1 1/4"	1 1/2"	2"	2 1/2"	3"	3 1/2"	4"	5"	6"	
d = D	Size Of Thread	9.728	13.157	16.662	20.995	26.441	33.249	41.910	47.803	59.614	75.184	87.884	100.330	113.030	138.430	163.830	
a	Distance Between The Plane Of Extremities Of Pipe And Plane Of Measure	4.0	6.0	6.4	8.2	9.5	10.4	12.7	12.7	15.9	17.5	20.6	22.2	25.4	28.6	28.6	
P	Pitch	0.907	1.337	1.337	1.814	1.814	2.309	2.309	2.309	2.309	2.309	2.309	2.309	2.309	2.309	2.309	
Z	Number of Threads for 25.4mm	28	19	19	14	14	11	11	11	11	11	11	11	11	11	11	
d2 = D2	Middle Size	9.147	12.301	15.806	19.793	25.279	31.770	40.431	46.324	58.135	73.705	86.405	98.851	111.551	136.951	162.351	
d3 = D1	Size of Stone	8.566	11.445	14.950	18.631	24.117	30.291	38.952	44.845	56.656	72.226	84.926	97.372	110.072	135.472	160.872	
H1		0.581	0.856	0.856	1.162	1.162	1.479	1.479	1.479	1.479	1.479	1.479	1.479	1.479	1.479	1.479	
r~		0.125	0.184	0.184	0.249	0.249	0.317	0.317	0.317	0.317	0.317	0.317	0.317	0.317	0.317	0.317	
L1	Length of Useful Thread	6.5	9.7	10.1	13.2	14.5	16.8	19.1	19.1	23.4	26.7	29.8	31.4	35.8	40.1	40.1	

DIMENSIONS & LENGTHS OF THREAD

- Matching conical outside thread with cylindrical inside thread

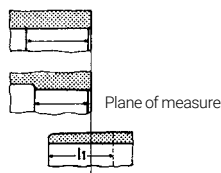

Maximum length of inside thread in case of manual screw

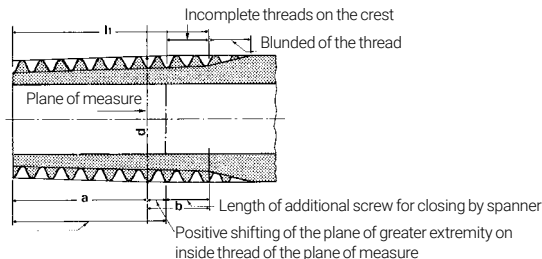

Pipe Size:	1/8"	1/4"	3/8"	1/2"	3/4"	1"	1 1/4"	1 1/2"	2"	2 1/2"	3"	3 1/2"	4"	5"	6"	
OUTSIDE PIPE THREAD																
Size of Thread in Plane of Measure (d)	9.728	13.157	16.662	20.995	26.441	33.249	41.910	47.803	59.614	75.184	87.884	100.330	113.030	138.430	163.830	
Nominal Dimension	4.0	6.0	6.4	8.2	9.5	10.4	12.7	12.7	15.9	17.5	20.6	22.2	25.4	28.6	28.6	
Length of Measure (a)	Shiftings mm≈	±0.9	±1.3	±1.3	±1.8	±1.8	±2.3	±2.3	±2.3	±2.3	±3.5	±3.5	±3.5	±3.5	±3.5	
	Shiftings Threads	±1	±1	±1	±1	±1	±1	±1	±1	±1	±1 1/2	±1 1/2	±1 1/2	±1 1/2	±1 1/2	
	Dimension Max.≈	4.9	7.3	7.7	10.0	11.3	12.7	15.0	15.0	18.2	21.0	24.1	25.7	28.9	32.1	32.1
	Dimension Min.≈	3.1	4.7	5.1	6.4	7.7	8.1	10.4	10.4	13.6	14.0	17.1	18.7	21.9	25.1	25.1
Tolerance of Screw (b)	mm≈	2.5	3.7	3.7	5.0	5.0	6.4	6.4	7.5	9.2	9.2	9.2	10.4	11.5	11.5	
	Threads	2 1/4	2 3/4	2 3/4	2 3/4	2 3/4	2 3/4	2 3/4	2 3/4	3 1/2	4	4	4	4 1/2	5	5
Min. Length of Useful Thread (L1)	For a Nominal 6.5	9.7	10.1	13.2	14.5	16.8	19.1	19.1	-	23.4	26.7	29.8	31.4	35.8	40.1	40.1
	For a Max.	7.4	11.0	11.4	15.0	16.3	19.1	21.4	21.4	25.7	30.2	33.3	34.9	39.3	43.6	43.6
For a Min.	5.6	8.4	8.8	11.4	12.7	14.5	16.8	16.8	21.1	23.2	26.3	27.9	32.3	36.6	36.6	
INSIDE PIPE THREAD																
Length of Useful Thread (L2)	7.4	11.0	11.4	15.0	16.3	19.1	21.4	21.4	-	25.7	30.2	33.3	34.9	39.3	43.6	43.6
Shifting of Plane of Extremity on the Plane of Measure	mm ≈	±1.1	±1.7	±1.7	±2.3	±2.3	±2.9	±2.9	±2.9	±2.9	±3.5	±3.5	±3.5	±3.5	±3.5	±3.5
	Threads	±1 1/4	±1 1/4	±1 1/4	±1 1/4	±1 1/4	±1 1/4	±1 1/4	±1 1/4	±1 1/4	±1 1/2	±1 1/2	±1 1/2	±1 1/2	±1 1/2	±1 1/2
Shifting on Sizes of Middle Thread & of Stone		±0.071	±0.104	±0.104	±0.142	±0.142	±0.180	±0.180	±0.180	±0.180	±0.217	±0.217	±0.217	±0.217	±0.217	±0.217

BOLT & STUD DIMENSIONS FOR ASA (USAS) FLANGES TO USAS B16.5

Nominal Pipe Size	1/2"	3/4"	1"	1 1/4"	1 1/2"	2"	2 1/2"	3"	3 1/2"	4"	5"	6"	8"	10"	12"	14"	16"	18"	20"	24"
150LB. FLANGES																				
Number of Bolts	4	4	4	4	4	4	4	4	8	8	8	8	8	12	12	12	16	16	20	20
Dia. of Bolts	1/2"	1/2"	1/2"	1/2"	1/2"	5/8"	5/8"	5/8"	5/8"	5/8"	3/4"	3/4"	3/4"	7/8"	7/8"	1"	1"	1 1/8"	1 1/8"	1 1/4"
Machine Bolts	1 3/4"	2"	2"	2 1/4"	2 1/4"	2 1/4"	3"	3"	3"	3"	3 1/4"	3 1/4"	3 1/2"	3 3/4"	4"	4 1/4"	4 1/2"	4 3/4"	5 1/4"	5 3/4"
Stud Bolts	2 1/4"	2 1/4"	2 1/2"	2 1/2"	2 3/4"	3"	3"	3 1/4"	3 1/2"	3 1/2"	3 1/2"	3 3/4"	3 3/4"	4 1/2"	4 1/2"	5"	5 1/4"	5 3/4"	6"	6 3/4"
300LB FLANGES																				
Number of Bolts	4	4	4	4	4	8	8	8	8	8	8	12	12	16	16	20	20	24	24	24
Dia. of Bolts	1/2"	5/8"	5/8"	5/8"	3/4"	5/8"	3/4"	3/4"	3/4"	3/4"	3/4"	3/4"	7/8"	1"	1 1/8"	1 1/8"	1 1/4"	1 1/4"	1 1/4"	1 1/2"
Machine Bolts	2	2 1/2	2 1/2	2 3/4	3	3	3 1/4	3 1/2	3 3/4	3 3/4	4	4 1/4	4 3/4	5 1/4	5 3/4	6	6 1/2	6 3/4	7	7 3/4
Stud Bolts	2 1/2"	2 3/4"	3"	3"	3 1/4"	3 1/2"	3 3/4"	4"	4 1/4"	4 1/4"	4 1/2"	4 3/4"	5 1/4"	6"	6 1/2"	6 3/4"	7 1/4	7 1/2"	8"	9"
400LB FLANGES																				
Number of Bolts	4	4	4	4	4	8	8	8	8	8	8	12	12	16	16	20	20	24	24	24
Dia. of Bolts	1/2"	5/8"	5/8"	5/8"	3/4"	5/8"	3/4"	3/4"	7/8"	7/8"	7/8"	7/8"	1"	1 1/8"	1 1/4"	1 1/4"	1 3/8"	1 3/8"	1 1/2"	1 3/4"
Machine Bolts	3"	3"	3"	3"	4"	4"	4"	4"	5"	5"	5"	5"	6"	7"	7"	8"	8"	8"	9"	10"
600LB FLANGES																				
Number of Bolts	4	4	4	4	4	8	8	8	8	8	8	12	12	16	20	20	20	20	24	24
Dia. of Bolts	1/2"	5/8"	5/8"	5/8"	3/4"	5/8"	3/4"	3/4"	7/8"	7/8"	1"	1"	1 1/8"	1 1/4"	1 1/4"	1 3/8"	1 1/2"	1 3/8"	1 3/8"	1 7/8"
Machine Bolts	3"	3 1/4"	3 1/2"	3 3/4"	4"	4"	4 1/2"	4 3/4"	5 1/4"	5 1/2"	6 1/4"	6 1/2"	7 1/2"	8 1/4"	8 1/2"	9"	9 3/4"	10 1/2"	11 1/4"	12 3/4"
900LB FLANGES																				
Number of Bolts	4	4	4	4	4	8	8	8	-	8	8	12	12	16	20	20	20	20	20	20
Dia. of Bolts	3/4"	3/4"	7/8"	7/8"	1"	7/8"	1"	7/8"	-	1 1/8"	1 1/4"	1 1/8"	1 3/8"	1 3/8"	1 3/8"	1 1/2"	1 5/8"	1 5/8"	2"	2 1/2"
Machine Bolts	4"	4 1/4"	4 3/4"	4 3/4"	5 1/4"	5 1/2"	6"	5 1/2"	-	6 1/2"	7 1/4"	7 1/2"	8 1/2"	9"	9 3/4"	10 1/2"	11"	12 3/4"	13 1/2"	17"
1,500LB FLANGES																				
Number of Bolts	4	4	4	4	4	8	8	8	-	8	8	12	12	12	16	16	16	16	16	16
Dia. of Bolts	3/4"	3/4"	7/8"	7/8"	1"	7/8"	1"	1 1/8"	-	1 1/4"	1 1/2"	1 3/8"	1 3/8"	1 3/8"	2"	2 1/4"	2 1/2"	2 3/4"	3"	3 1/2"
Machine Bolts	4"	4 1/4"	4 3/4"	4 3/4"	5 1/4"	5 1/2"	6"	6 3/4"	-	7 1/2"	9 1/2"	10"	11 1/4"	13 1/4"	14 3/4"	16"	17 1/2"	19 1/4"	21"	24"
2,500LB FLANGES																				
Number of Bolts	4	4	4	4	4	8	8	8	-	8	8	12	12	12	-	-	-	-	-	-
Dia. of Bolts	3/4"	3/4"	7/8"	1"	1 1/8"	1"	1 1/8"	1 1/4"	-	1 1/2"	1 3/4"	2"	2"	2 1/2"	2 3/4"	-	-	-	-	-
Machine Bolts	4 3/4"	4 3/4"	5 1/4"	5 3/4"	6 1/2"	6 3/4"	7 1/2"	8 1/2"	-	9 3/4"	11 1/2"	13 1/2"	15"	19"	21"	-	-	-	-	-

Machine bolt lengths include height of point; stud-bolt lengths do not include height of point. Length shown is for raised face joints

NOTES

A

Abrasives

Carbide Burrs 254–255
 Flap Discs 125
 Flap Wheels 123
 Grinding Discs & Wheels 122–123
 Mounted Points 123
 Sanding Discs 124
 Sanding Pads 124–125
 Sanding Paper 127–128
 Sharpening Stone 129
 Surface Preparation Discs 125
 Wheel Dressers 128
 Wire Brushes & Wheels 126–127

Absorbent Material

Spill Control 38–40

Acetone

Solvent 451

Acetylene

Bottle Keys 118
 Coupling 114
 Flashback Arrestors 112
 Hose 114
 Hose Connector 115
 Hose Reels 477
 Regulators 108–109
 Tips & Nozzles 110–111, 113
 Welding & Cutting Kits 115–116

Acids & Chemicals

Acetone 451
 Methylated Spirits 451
 Thinners 451
 Turpentine 451

Adaptors

Compression Tester 386
 Pressure Gauge – Hydraulic 476
 Sleeves – Bearing Shaft 513
 Socket 171, 189

Adaptors – Hose/Pipe

Airline 493
 Brass 495–496
 Camlock 484–485
 Plugs 495
 Reducing 496–497, 499
 Stainless Steel 497

Adhesives

Araldite 460
 Assembly 466
 Bonding 461
 Chemical Anchors 289
 Construction 461
 Contact 461
 Epoxy 460–461
 Foam 463
 Gasketing 466–467
 Instant 460
 Lubricants 443
 Primer 462
 Retaining Compound 462
 Sealants 464–466
 Solvent Cement 462
 Structural 461
 Threadlocker 468
 Thread Sealant 467
 Windscreen 466

Aerial

Whip Flag 58

Aerogard

Insect Repellent 413

Air

Duster 358
 Engine Cleaner 358
 Filter Regulators 504
 Filters 503
 Horn 59
 Hose 479–481
 Hose Assembly 482
 Hose Reels 476–477
 Jacks 387–388
 Lubricators 504
 Pressure Gauges 503
 Spray Guns 358
 Tool Oil 441

Air Compressors

Diesel 330
 Electric 327–329
 Petrol 330
 Portable 327–328, 330

Air Freshener

Spray 400

Airline

Filter Regulators 504
 Filters 503
 Fittings 493
 Lubricators 504
 Pressure Gauges 503

Air Operated

Diaphragm Pumps 432
 Engraving Pen 150
 Grease Guns 418
 Grease Pumps 419–421
 Guns – Blow 150
 Oil Pumps 427–428
 Power Tools 146–150

Air/Water

Hose 479–480
 Hose Assembly 482
 Hose Reels 477

Alarm

Reversing 380

Alaskan

Sawmill 153

Alcohol

Methylated Spirits 451
 Wipes 400

Alkaline

Batteries 382

Allen Key

Hex Keys 233–235
 Hex Wrenches 235

Allthread

Threaded Rod 288
 Threaded Rod – Stainless Steel 288

Aluminium

Blind Rivets 292–293
 Camlocks 484–485
 Cleaner 451
 Dust Caps & Plugs 485
 Fasteners 293
 Floats 341
 Flux 117
 Foil Tape 347
 Ladders 359–361
 Repair Putty 456–457
 Tool Boxes 159–160
 Torches 374
 Welding Wire 102

Anchors

Bolt 289
 Chain 307
 Chemical Adhesive 289
 Height Safety 31–32

Angle

Gauges – Torque 190
 Levels 242

Angle Grinders

Cordless 134–136
 Electric 138
 Pneumatic 146

Annular

Cutters 265

Antibacterial

Wipes 400

Anti-Corrosion

Lubricants 443
 Paint 355–356

Anti-Freeze

Coolant 453

Anti-Seize

Copper 435
 Food Grade 436
 Nickel 435

Anti-Slip

Paint 356
 Safety Tape 57

Anti-Spatter

Welding Lubricant 118

Anti-Vibration

Hammers 222

Anvil

Forged 333

Appliance

Test Tags 53

Applicators

Caulking Guns 468

Aprons

PVC 79
 Welding – Leather 95

Araldite

Adhesive 460

Arbors

Drill Chuck 236
 Holesaws 266

Arc Welding

Gouging Torch 108
 Inverters 100
 Lenses 93
 Machines 98–101

Argon

Hose – Welding 114
 Regulators 109

Arrestors

Flashback 112

Ashtrays

Cigarette 413

Asphalt

Cutting Blades 251–252

Assembly

Hose 482

Assortment Kits

Fasteners – Bolts, Screws & Nuts 289
 Fasteners – Clips 293
 Fasteners – Nuts 293
 Fasteners – Nuts & Bolts 290
 Fasteners – Pins 293



ASSORTMENT KITS – BITS

Fasteners – Rivets	292–293	Polyweave	319	Jumper Leads	384
Fasteners – Screws & Nuts	289–290	Tool	137, 162	Load Testers	383
Fasteners – Stainless Steel	290–291	Balancer		Post Cleaning Products	384
Fasteners – Washers	290–291	Wheel	389	Terminals	384
Auger		Ball		Beach	
Drill – Petrol Powered	152	Hex Keys	234–235	Umbrella	413
Automotive		Valves	500–501	Beacon	
Aerial Flag	58	Ball Bearings		Lighting	58–59
Battery Chargers	382–383	Deep Groove	510	Bead	
Bearing Separators	212	Parallel Bore	511	Breaker	392
Body Filler	456	Roller	511–512	Bearing	
Body Repair Kit	385	Spherical	511	Adaptor Sleeves	513
Brake Fluid	454	Tapered Bore	511–512	Ball	510
Cleaners & Degreasers	402	Ballmarker		Blue Grease	454
Compressor – Piston Ring	213	Ink, Tips & Bottles	354	Gear Puller	212
Compressor – Spring	213	Ball Pein		Grease	436
Coolant	453	Hammers	223	Housing	514
Cranes & Hoists	388–389	Hammers – Non-Sparking	223	Inner	513
Cylinder Hones	386	Bamboo		Scraper	240
Electrical Parts	379–381, 384	Socks	89	Seals	514
Engine Cleaners	453	Band		Separator Puller	212
Engine Oils	437–439	Stainless Steel	487	Belts	
Filter Kits	385	Bandages		Back Support	80
Floor Creepers	390	Pipe Repair	445–446	Finishing	139
Fuel Cans	393–394	Band Saws		Sanding	128
Fuel Treatment	452–453	Blades	252	Tool Bag	162
Fuses & Crimps	381	Electric	343	V-Belts	516–517
Gear Oils	440	Bannister		Belt Sanders	
Gear Pullers	212	Brush	404	Bench – Electric	139
Hose – Radiator	480	Bar		Bench	
Inspection Mirrors	240	Clamps	204	Drill Press	141
Jacks & Stands	387–388	Crow	214	Grinders	139
Jumper Leads	384	Fence	214	Grinders – Attachment	139
Jump Starters	383	Pinch	214	Lathes	332
Lighting	58–59, 377–379	Podger	215	Vices	334–336
Lubricants	443	Pry	214–215	Work Bench	158
Oil Drainer	393	Scaling	215	Bench Grinders	
Pick-Up Tools	240	Solder	117	Attachment	139
Pressure Tester	386	Spoon	214	Electric	139
Protectants	402	Wrecking	215	Wheels	122–123
Radiator Cleaners	453	Barrel		Bench Stone	
Reflectors	377	Drifts	218	Sharpening	129
Reversing Alarm	380	Hook	300	Benders	
Roller Stud Extractor	213	Unions	498	Pipe & Tube – Hand Operated	333
Spray Gun Kit	358	Barrier		Pipe & Tube – Hydraulic	333
Stop Leak	454	Bunting Flags	56	Pipe & Tube – Power Operated	334
Trailer Cables	380	Cream	400	Rebar	144, 212
Transmission Fluid	440	Mesh	56	Rod	212
Tyre Repair	385	Tape – Traffic Safety	56–57	Bevel	
Tyre/Wheel Accessories	389, 391–392	Base Drills		Sliding T-Bevel	250
Vehicle Ramps	389	Magnetic	141	Bi-Focal	
Wheel Balancer	389	Bathroom		Safety Glasses	15
Wheel Chocks & Stops	390	Cleaners	451	Bilge	
Aviation		Deodorisers	403	Pump	432
Tin Snips	209	Disinfectant	400	Bins	
B		Sealant	464	Parts Storage	319
Backing		Toilet Brush Set	403	Bins – Rubbish	
Grout	364	Urinal Pads	403	Ashtrays	413
Pad – Discs	124	Batteries		Plastic	408–409
Backpack		Alkaline	382	Wheeler	409
Sprayer	343	Cordless Tool	137	Bits	
Back Support		Lantern	382	Drill – Centre	264
Belt	80	Battery		Drill – Endmills	264
Bags		Cables	384	Drill – Hammer	262
Bulker	319	Chargers	382–383	Drill – Holesaw	266
Contaminated Waste	42	Chargers – Cordless Tool	137	Drill – Jobber	258–260
Nailbag	162	Clamps	384	Drill – Masonry	262
		Demineralised Water	385	Drill – Reduced Shank	260
		Hydrometer	385	Drill – Slot Drills	264
		Jar	385	Drill – Step	263

Drill – Taper Shank	261	Safety – Zip-Up	87–88	Industrial	405–406
Nutsetters	237	Socks	89	Lobby	405
Power	236–237	Bore		Brushcutter	
Blades		Gauge	248	Petrol Powered	154
Band Saw	252	Borescope		Brushes	
Circular Saw	251–252	Camera	244	Bannister	404
Diamond Cutting	251–252	Bottle		Boot Cleaning	404
Hacksaw	252	Jacks	387	Dustpan	404–405
Jigsaw	253	Key – Oxy/Acetylene	118	Paint	356
Multi-Tool	144, 254	Bottled		Scrubbing	404
Reciprocating Saw	253	Drinking Water	413	Toilet	403
Utility/Safety Knife	228	Bouffant Cap		Brushes – Abrasives	
Blankets		Hair Net	79	Wire – Hand	126
Fire	46	Bow		Wire Wheel	126–127
Welding	96	Shackles – Commercial	305–306	BST	
Blanking		Shackles – Lifting	305	Material Specifications	531
Grommets	381	Box		BSW	
Blind		Cutter	228	Tapping Drill Size Chart	529–530
Flange	506	Lockout/Tagout	50	Bubble	
Rivets	292–293	SDS Storage	52	Wrap	352
Blocks		Site	158–159	Buckets	
Chain	303	Tool	158–160, 162	Greaser	421
Lever	303	Bracket		Mop	407–408
Sanding	128	Automotive Lighting	379	Plastic	319, 408
Sheave	304	Fire Extinguisher	46	Rubber	408
Snatch	304	Helmet – Visor	18	Stainless Steel	408
Toilet Deodorant	403	Wheel Chock	390	Steel	408
Blow		Braided		Buckles	
Guns	150	Rope	308	Strapping	350
Blower		Brake		Strapping – Stainless Steel	487
Petrol Powered	155, 343	Cylinder Hones	386	Bug	
Blowpipe		Fluid	454	Repellent	413
Hand Piece	112	Parts Cleaner	450	Building	
Boards		Brass		Backing Grout	364
Power	369	Battery Terminals	384	Bricklayers Line	337
Bob		Clean & Polish	402, 444	Film	364
Plumb	242	Fittings – Hose	494	Site Boxes	158–159
Body Filler		Fittings – Pipe	495–496	Tripod	244
Repair	456	Fittings – Tube	496	Bulbs	
Body Repair		Flux	117	Light	379
Automotive Kit	385	Grommets	363	Bulk	
Bollards		Padlocks	365–366	IBC Storage	319
Traffic	56	Shim	521	Bulker	
Bolt		Valves	500–501	Bags	319
Anchor	289	Wire Wheel Brushes	126	Bulkhead	
Assortment Kits	289–290	Brazing		Unions	492
Clamps	484	Flux	117	Bulldog	
Container Seals	308	Rods	106	Boots	84, 86, 88
Cutter	209	Breaker		Gumboots	83
Hex Head	279–281	Bead	392	Socks	89
High Tensile	279–281	Demolition	342	Bullfloats	
Material Specifications	531, 534	Brick		Aluminium	341
Stainless Steel	281	Cutting Blades	252	Bump	
Bonding		Cutting Wheels	121	Caps	27
Adhesive	461	Drill Bits	262	Buna	
Book		Ice	412	Seal	485
Scaffold Inspection Report	362	Saws	342	Bunds	
Booms		Storage Cage	318	Floor	43–44
Spill Control	38–40	Bricklayers		Spill Containers	44–45
Booster		String Line	337	Bunting	
Grease Gun	422	Brim		Flags	56
Boots		Hard Hat	27	Burrs	
Brush Cleaner	404	Bronze		Carbide	254–255
Covers	79	Rods	364	Bushes	
Gumboots	82–83	Brooms		Fittings – 600–1,000lbs	499
Laces	89	Dust Mop	405	Fittings – Brass	495
Safety – Elastic-Sided	84–85	General Purpose	405	Fittings – Stainless Steel	497
Safety – Lace-Up	86–87	Handle	407	Pipe Fittings – Galvanised	496
Safety – Pull-On	89	Heads	405–406		

**BUTANE – CHUCKS**

- Butane**
Torch 115
- Button**
Die Holder 270
Dies 271–272
- Button Head**
Grease Couplers 423
- C**
- Cabinets**
Dangerous Goods 320–321
Fire Hose Reel 47
Tool 161
Work Bench 158
- Cable**
Battery 384
Connector – Welding 108
Cutter 210
Glands 381
Lockout Device 51
Lugs 381
Pullers 303
Starter 384
Tester 369
Ties 366–367
Trailer 380
Welding 107
Winch Kits 311
Wire Rope 298
- Cage**
Brick 318
Storage 318–319
Storage – Gas Cylinder 321
Work Platform 318
- Calcium**
Remover 451
- Calipers**
Dial 245
Digital 245
Inside 246
Jenny 245
Outside 246
Vernier 245
- Camera**
Borescope 244
- Camlock**
Adaptors & Couplings 484–485
Dust Caps 485
Dust Plugs 485
Joiners 485
Seals 485
- Cans**
Fuel 393–394
Oil 394
- Cantilever**
Tool Box 160
Tool Box – Kit 163–164
- Canvas**
Grommets 363
Tool Bags 162
- Caps**
Bump 27
Dust – Camlock 485
Dust – Hydraulic 475
Fittings – Stainless Steel 498
Star Picket 364
- Car**
Battery Chargers 382–383
Hoist 389
Jacks & Stands 387–388
Jumper Leads 384
Jump Starters 383
Tyre/Wheel Accessories .. 389, 391–392
Wheel Balancer 389
Wheel Chocks & Stops 390
- Carbide**
Burrs 254–255
- Carbine**
Hooks 306
- Carbon**
Gouging Rods 108
- Cargo**
Covers – Tarpaulin 363
Load Skate 316
Trolley 313
- Cargo Pants**
Insect Repellent 74
Reflective 74
- Carpenters**
Pencil 352
Square 250
- Cart**
Janitor’s Trolley 409
Hand Trolleys 313
- Cartridge**
Respirator Filters 22–23
- Castors**
Nylon 316
Plastic 315
Poly 316
Rubber 316
- Caulking**
Gun 468
Nozzles 468
- Caution**
Safety Tags 52
Safety Tape 57
- Cement**
Solvent Adhesive 462
- Centimetre/Inch**
Conversion Chart 526
- Centre**
Drill Bits 264
Gauge 248
Punches 216–217
- Ceramic**
Abrasive Discs 125
Repair Putty 457
- Chain**
Anchor 307
Blocks 303
Care & Use 299
Hoists 303
Hooks 301–302
Lifting 299
Lifting Slings 299
Links – Lifting 300
Loadbinder 309
Locking Pliers 204
Lubricants 442–443
Oil 441
Pipe Vice 336
Plastic 307
Proof Coil 307
Roller 519
- Short Link 307
Stainless Steel 307
Tongs 199
Transport 308
Working Load Chart 299
Wrench 199
- Chainsaw**
Chaps 80
Chaps – Kit 80
Files 220
Mills 153
Petrol Powered 152–153
- Chalk**
Engineers 354
Holder 354
- Champion Parts**
Kits – Brass Olives 496
Kits – Circlips 520
Kits – E-Clips 520
Kits – Extension & Compression Springs 363
Kits – Grommets 381
Kits – Grub Screws 292
Kits – Nuts 293
Kits – O-Rings 520
Kits – Pins 293
Kits – Rivets 293
Kits – Screws & Nuts 290
Kits – Washers 290–291
- Changeover**
Switches – Generator 326
- Chaps**
Chainsaw 80
- Chargers**
Battery 382–383
Battery Clamps 384
Battery – Cordless Tool 137
- Chemical**
Anchoring Adhesive 289
Funnels 395
Gloves 10–11
Goggles 16–17
Pumps 429, 432
Spill Control 39–40, 42–43
- Chemicals & Acids**
Acetone 451
Methylated Spirits 451
Paint Stripper 451
Thinners 451
Turpentine 451
- Chest**
Tool 161
- Chipping**
Hammer 118
- Chisels**
Cold 216
Flat 216
Hammer – Pneumatic 150
Needle Scalers 149
Wood 216
- Chocks**
Wheel 390
- Chop Saws**
Cutting Wheels 122
- Chrome**
Polish 402, 444
Sockets 179–186
Sockets – Sets 172–179, 183–184
- Chucks**
Arbor 236

Cigarette		Cleaning		Combination	
Ashtray	413	Battery Post	384	Padlocks	365
Circlips		Cleaning Equipment		Pliers	201–202
Kits	520	Brooms	405–406	Spanners	192–196
Pliers	201, 203	Brushes – Boot Cleaning	404	Square	250
Circuit		Brushes – Dustpan Set	404–405	Compactors	
Tester	369	Brushes – Scrubbing	404	Plate	338
Circuit Breaker		Brushes – Toilet	403	Compounds	
Lockout/Tagout	51	Cloths	403–404	Cutting	448
Circular Saws		Dust Mop	405	Fitting	454
Blades	251–252	Janitor's Trolley	409	Grinding	448
Electric	142	Mop Buckets	407	Jointing	463
Petrol Powered	152	Mops	406–407	Lapping	448
Citrus		Rags	403	Retaining	462
Cleaners	449	Sponges/Scourers	404	Welding	457
Clamps		Squeegees	406	Compression	
Band	487	Wipes	403–404	Packing	458
Bar	204	Cleaning Machines		Springs	363
Battery	384	Floor Sweepers	405	Compressors	
Earth	107	Pressure Cleaners	410–411	Air – Diesel	330
F-Clamps	204–205	Vacuum Cleaners	409	Air – Electric	327–329
G-Clamps	204	Clevis		Air – Petrol	330
Hose	484, 486	Clutches	301	Drain Valves	504
Locking Pliers	203–204	Lifting Hooks	301–302	Oil	441
Meters	372	Pin – Assortment Kits	293	Piston Ring	213
Plate	304	Clip		Spring	213
Strap Buckles	487	Glove	8	Concentrates	
T-Bar	205	R-Clips	293	Cleaners	401–402
Welding	107, 204	Cloth		Concrete	
Woodworking	205	Cleaning	403–404	Crane Attachment	318
Claw		Emery	127–128	Cutting Blades	252
Couplings	483	Microfibre	403	Cutting Wheels	121
Couplings – Gasket Seals	483	Tape	347	Drill Bits	262
Hammers	222	Wipes	403–404	Lifting Eye	302
Pick-Up Tool	240	Clothing		Concreting	
Shortening Hooks	301	Cargo Pants	74	Floats	341
Cleaners		Chaps	80	Floor Saw	343
Acetone	451	Coveralls	64, 76–77, 79	Jointer	341
Automotive	402, 453	Drill Wear	63–64, 66–68	Mixers	340
Bore Water	444	Fire Retardant	76–77	Screeds	341
Calcium	451	Hats	27	Trowels	342
Citrus	449	Insect Repellent	72–74, 76	Vibrator Poker	340
Concentrate	401–402	Jackets	69	Cones	
Degreasers	401–402, 448–451	Jeans	74	Traffic	55
Disinfectant	400	Pants	63, 74, 76	Confined Space	
Electrical Parts	450	Shirts	66–68, 72–73, 76	Harnesses	28–29
Fibreglass	450	Shorts	64	Connecting	
Industrial	401–402, 448–449	Socks	89	Links – Lifting	300
Lens	17	Vests	80	Connectors	
Lime	451	Wet Weather	69–70, 72	Cable – Welding	108
Marine	450	Women's	63, 73	Fittings – Brass	115
Metal	444, 451	CLR		Fittings – Push-In	492
Methylated Spirits	451	Cleaner & Remover	451	Fittings – Tube	492
Multi-Purpose	449	Club		Hose – Welding	115
Paint	451	Hammers	224–225	Construction	
Parts	450	Clutch		Adhesive	461
Rust	444, 451	Shortening	301	Sealant	465–466
Spray	401	Coat		Construction Equipment	
Stainless Steel	451	Rain	70	Backing Grout	364
Surface	400–402, 451	Cobalt		Bricklayers Line	337
Thinner	451	Drill Bits	258–259	Bronze Rods	364
Wax	451	Toolbits	267	Builders Film	364
Welding Tips	118	Coil		Concrete Mixers	340
Window/Glass	401	Hose	481	Concrete Vibrator	340
Wipes	400	Cold		Demolition Breakers	342
Cleaners – Hand		Chisel	216	Edgers	342
Citrus	399	Galvanising	355	Floats	341
Gel	399	Galvanising Primer	355	Floor Saws	343
Grit	399			Lighting Tower	343
Heavy Duty	399			Nylon Rods	364



CONSTRUCTION EQUIPMENT – CYLINDER

Plate Compactors	338	Cordless	Grease Guns	418	Crimped	Wire Wheel Brushes	126–127
Scaffolding	362		Hydraulic Pump	474	Crimping Tools	Pliers	208
Scaffolding Tools & Accessories	362	Cordless Power Tools				Steel Strapping	350
Screeds	341	Batteries & Chargers	137				
Tamping Rammers	339	Drill/Drivers	134–135				
Trowel Machines	342	Drivers – Impact	135				
Trowels	342	Grinders – Angle	134–136				
Vee Jointer	341	Hammer Drills	134–135				
Vibratory Rollers	339	Kits	134–136				
Contact		Planer	136				
Adhesive	461	Rotary Hammers	135				
Cleaner	450	Sanders – Orbital	137				
Tips	103	Sanders – Polishers	136				
Container		Saws – Reciprocating	136				
Bolt Seals	308	Screwdriver – Drywall	136				
Bottles – Plastic	412	Wrenches – Impact	135–136				
Fuel	393–394	Cork					
Hooks	301	Rubber Gasket	459				
IBC Storage	319	Corrosion					
Oil	394	Inhibitors	443, 445, 453				
Parts Bins	319	Penetrants	444				
Ramp	312	Rust Remover	444				
Storage	319	Corrosive Substances					
Containment		Storage Cabinet	321				
Spill Control	38–45	Cotter					
Contaminated Waste		Pins – Assortment Kits	293				
Disposal Bags	42	Cotton					
Incinerator	43	Gloves	2				
Contractors		Countersunk					
Tool Bags	137	Socket Screws	287				
Wheelbarrow	316	Couplings					
Control		Acetylene	114				
Nozzles	431	Airline	493				
Valves	422, 428	Button Head	423				
Conversion Charts		Camlock	484–485				
Area & Volume	525	Claw	483				
Drill Tapping Sizes	528–529	Claw – Gasket Seals	483				
Gauge	524	Grease Gun	422–423				
Length & Size	526	Hydraulic	423, 475				
Mass	526	Coveralls					
Metric Fine	528	Chemical Resistant	77, 79				
Pitch & Thread	527	Disposable	77, 79				
Power & Force	524	Drill Wear	64				
Pressure	528	Fire Retardant	76–77				
Temperature	525	High Visibility	64, 77, 79				
Converter		Insect Repellent	76				
Rust	444	Covers					
Cooking		Spill Pallet	45				
Apron	79	Tarpaulins	363				
Coolant		Crack					
Automotive	453	Detection	455				
Coolers		Crane					
Ice Bricks	412	Concrete Spreader	318				
Water	412	Cylinder Trolley	313				
Cooling		Engine	388				
Fans	331	Storage Cage	318, 321				
Pressure Tester	386	CRC					
Copper		Contact Cleaner	450				
Anti-Seize	435	Degreasers	450				
Club Hammers	225	Lectra Clean	450				
Flux	117	Lubricants	442–443				
Sledge Hammers	224–225	Parts Cleaner	450				
Tubing	487	Penetrants	444				
Washers – Assortment Kits	291	Protectants	445				
Welding Rods	106	Cream					
Cord		Barrier	400				
Bricklayers Line	337	Creepers					
Extension	368	Mechanics	390				
O-Ring	520	Wire Rope	303				
Safety Glasses	15						

D

Danger

Safety Signs	54
Safety Tags	52–53
Safety Tape	56

Dangerous Goods

Storage Cabinets	320–321
Storage Cage	321

Dead Blow

Hammer	225
--------------	-----

Deadbolt

Padlock	366
---------------	-----

Dee

Shackles – Commercial	305
Shackles – Lifting	304–305

Degreasers

Acetone	451
Citrus	449
Concentrate	401–402
Engine	450
Industrial	401–402, 448–449
Workshop	449

Delivery

Hose	479–482
------------	---------

Deluge

Showers	36–37
---------------	-------

Demineralised

Water	385
-------------	-----

Demolition

Breakers	342
Hammers	140

Denim

Jeans	74
-------------	----

Denso

Pipe Repair Wrap	446
Primer	445
Profiling Mastic	464
Tape	445–446

Densyl

Tape	445
------------	-----

Deodorisers

Toilet & Urinal	403
-----------------------	-----

Detection

Crack & Leak	455
Dye	455
Particle	455
Universal Scanner	244

Diagonal

Cutting Pliers	201, 207
----------------------	----------

Dial

Calipers	245
Gauges	246
Gauge Stand	246

Diamond

Cutting Blades	251–252
Rebar Bender/Straightener	144
Rebar Cutter	144

Diaphragm

Pumps	432
-------------	-----

Die

Button	271–272
Holder	270
Nuts	271–272
Tap & Die Sets	273

Die Grinders

Electric	139
Pneumatic	146

Diesel

Air Compressors	330
Concrete Mixers	340
Control Nozzle	431
Engine Oils	438–439
Engines	326
Flow Meters	433
Fuel Treatment	452
Generators	325
Hose	480
Hose Reels	477
Jerry Cans	393–394
Plate Compactors	338
Pressure Tester	386
Pumps	427, 429–430, 432
Storage & Dispensing Kit	431
Trash Pumps	327
Water Pumps	326
Welder/Generator	101

Dinse

Plug	108
Socket	108

Dipping

Tape Measure	242
--------------------	-----

Discs

Backing Pad	124
Cutting Wheels	121
Fibre	124
Flap	125
Grinding	122
Sanding	124–125
Surface Preparation	125

Dishwashing

Cloths	403
--------------	-----

Disinfectants

Methylated Spirits	451
Spray	400
Surface	400
Wipes	400

Dispenser

Pallet Wrap	351
Steel Strapping	350

Dispensing

Pump Kits	420–422
Storage Kits	431

Disposable

Coveralls	77
Earplugs	25
Gloves	10
Hair Net	79
Poncho	72
Respirators	20
Shoe Covers	79

Disposal

Cigarette	413
Contaminated Waste	42–43

Distributor Blocks

Airline	493
---------------	-----

Dividers

Spring	245–246
--------------	---------

Document

Storage Box	52
-------------------	----

Dolly

Drum	314
------------	-----

Double Sided

Tape	348
------------	-----

Dowty Seals

Assortment Kit	290
----------------------	-----

Drain

Covers	40
Valve	504

Drainage

Shovels	239
---------------	-----

Drainer

Waste Oil	393
-----------------	-----

Dressers

Wheel	128
-------------	-----

Drift

Barrel	218
Punches	217

Drill

Bits	258–262, 264
Chuck Arbor	236
Press – Vices	334–335
Sleeve – Taper Shank	261
Tapping Sizes Table	528–529

Drill Bits

Annular Cutters	265
Centre	264
Endmills	264
Gauge	248
Hammer	262
Holesaws	266
Jobber	258–260
Masonry	262
Reduced Shank	260
Sets	259–260, 263, 272
Slot Drills	264
Step	263
Tap & Drill	272
Taper Shank	261
Taps	267, 270

Drill Clothing

Coveralls	64
Pants	63
Shirts	66–68
Shorts	64
Women's	63

Drills

Cordless	134–135
Electric	140
Electric – Magnetic Base	141
Electric – Press	141
Petrol Powered	152
Pneumatic	147

Drink

Bottled Water	413
Coolers	412

Drip

Trays	43
-------------	----

Drivers

Drill/Drivers – Cordless	134–135
Hex Key Set	233
Impact – Cordless	135
Impact – Set	190
Socket – Handle	190
T-Shaped	190

Drive Units

Petrol	340
--------------	-----

Driving

Lights	377–378
Reversing Alarm	380

Drum

Dolly	314
Hook	300
Lifter	314
Overpacks	43
Pumps	419–421, 425–429
Spill Containers & Bunds	44
Trolley	314

**DRUM PLUG – ENGINEERS****Drum Plug**

Wrench 199

Drum PumpsAir Operated 419–421, 427–428
Chemical 429
Filters 431
Fuel 429
Grease 419–421
Kits 420–421, 428
Oil 425–429
Rotary 429**Drum Rollers**

Vibratory 339

Drywall

Screwdriver 136

Dual

Transfer Gun 430

Duct

Tape 347

Ducting

Ventilation Tube 331

Dumpy

Level 244

DustCaps – Camlock 485
Caps – Hydraulic 475
Mop 405
Pan & Brush 404–405
Plugs – Camlock 485**Dust Masks**

Disposable 20

Dustpan

Brush Set 404–405

DuwellBrooms & Sweepers 405–406
Brush – Boots Cleaner 404
Brush – Dustpan 404–405
Brush – Scrubbing 404
Buckets 407–408
Bunting Flags 56
Chain 307
Cloths – Cleaning 403
Cooler Chests 412
Extension Lead Hook 368
Extension Leads 368
Fans 331
Floodlights 376
Generators 324
Handles – Broom/Mop 407
Hose – PVC 479, 482
Janitor’s Trolley 409
Mops 406–407
Packing Scales 352
Rope 308
Shovel 239
Site Boxes 158–159
Spill Control 38, 40
Sponges/Scourers 404
Squeegees 406
Tape Measures 241
Toilet Brush Set 403
Tool Boxes 159–160
Traffic Control 56
Trolleys 313
Urinal Screen Pads 403
Wet Floor Stand 55
Wheel Chocks & Stops 390
Wheel Recovery Track 390
Wire Hand Brush 126
Work Lights 376**Dye**

Flaw Finding 455

E**E-Clips**

Kit 520

EarmuffsFolding 26
Hard Hat/Cap Mounted 26
Headband 26
High Visibility 26
Neckband 26**Earplugs**Banded 25
Corded 25
Disposable 25
High Visibility 25
Reusable 25
Uncorded 25**Earth**Auger Drill 152
Clamps 107
Leakage Outlet 369**Edgers**

Concreting 342

ElbowsBrass 494–495
Fittings – Hose 494
Fittings – Pipe 495, 497–498
Fittings – Tube 492
Push-In 492
Stainless Steel 497
Steel 498**Electric**Air Compressors 327–329
Fuel Pump 430
Hoists 303
Hydraulic Pump 474
Motors 519
Oil Pump 427**Electrical**Automotive 379–381
Batteries 382
Battery Chargers 382–383
Battery & Starter Cables 384
Cable Glands 381
Cable Testers 369
Cable Ties 366–367
Circuit Tester 369
Crimps & Lugs 381
Earth Leakage Unit 369
Extension Leads 368
Fuse Kits 381
Grommets 381
Headlight Adaptors 379
Jump Starters & Cables 383–384
Lead Hook 368
Lockout/Tagout 52
Lubricants 443
Multimeter Leads 370
Multimeters 370–372
Parts Cleaners 450
Plugs 368
Power Boards 369
Sealant 464
Soldering Irons 116
Tape 347
Trailer Cables 380
Voltage Testers 370
Wire Terminal Kit 381**Electricians**Cutters 210
Lockout Kits 49
Scissors 208
Tool Bags 162
Tool Kits 163**Electric Power Tools**Drills – Impact 140
Drills – Magnetic Base 141
Drills – Press 141
Drills – Rotary Hammer 140
Grinders – Angle 138
Grinders – Bench 139
Grinders – Die 139
Hammers – Demolition 140
Heat Gun 144
Multi-Tools 143
Nibblers 143
Palm Router 143
Pipe Threader 274
Planer 144
Rebar Bender/Straightener 144
Rebar Cutters 144
Sanders – Orbital 145
Sanders – Polishers 145
Saws – Brick 342
Saws – Circular 142
Saws – Cut-Off 142
Saws – Glide 142
Saws – Jigsaws 143
Saws – Mitre 142
Saws – Table 142**Electrode**Heater 106
Holders 106–107
Welding 104, 106**Emergency**Deluge Showers 36–37
Eye/Face Wash 35–37
First Aid Kits 33–34
Safety Signs 54
Siren 59**Emery**

Cloth 127–128

EmissionHose 480
Packing 458**Endless**

Round Lifting Slings 296

Endmills

Drill Bits 264

EngineCleaners 453
Cleaning Guns – Air 150, 358
Coolant 453
Cylinder Hones 386
Degreasers 449–450
Diesel 326
Driven Welders 101
Floor Crane 388
Oil 437–439
Petrol 326
Stand 388
Stop Leak 454**Engineers**Bronze Rods 364
Chalk 354
Nylon Rods 364
Square 250
Tool Set 248
Vices 335–336

Engine Powered Tools

Blowers	155, 343
Brushcutter	154
Demolition Breaker	342
Drills – Earth Auger	152
Lawnmowers	155
Pruners	153
Sawmills	153
Saws – Chainsaws	152–153
Saws – Cut-Off	152
Trimmers – Grass	154
Trimmers – Hedge	153

Engraving

Pen	150
-----------	-----

Epoxy

Adhesive	460–461
Repair Putty	456–457

Eskies

Coolers	412
Ice Bricks	412

Etch

Primer	355
--------------	-----

Examination

Gloves	10
--------------	----

Expanding

Foam	463
------------	-----

Extension

Forklift Slippers	317
Grease Gun	424
Ladders	361
Leads	368
Socket	189
Socket – Square Drive	171
Springs	363

External

Circlips	520
Thread Files	275

Extinguisher

Bracket	46
Covers	47
Fire	46

Extractors

Ducting Tube	331
Easy Out Tools	424
Fans	331
Flexible Packing	458
Roller Stud	213
Screw	267

Eye

Lifting Hooks	301–302
Swivel – Stainless Steel	306
Turnbuckles	306

Eye/Face Wash

Bottle	35
Stations	35–37

Eye Protection

Face Shields	18
Goggles	16–17
Safety Glasses	13–15
Safety Signs	54



Face/Eye Wash

Bottle	35
Stations	35–37

Face Protection

Face Shields	18
Respirators	20–22
Safety Signs	54

Fans

Floor	331
Pedestal	331
Ventilation	331
Wall Mounted	331

Farm

Jacks	388
-------------	-----

Fasteners

Allthread	288
Anchor Bolts	289
Assortment Kits	289–293
Bolts	279–281
Chemical Anchors	289
Nuts	283
Nuts – Nyloc	284
R-Clips	293
Rivets	292–293
Screws – Grub	287
Screws – Socket	286–287
Washers – Copper	291
Washers – Flat	285
Washers – Nordlock	285
Washers – Spring	285

Fasteners – Stainless Steel

Allthread	288
Assortment Kits	290–292
Bolts	281
Nuts	283
Nuts – Nyloc	284
Screws – Self-Tapping	292
Set Screws	281
Washers – Flat	285
Washers – Spring	285

F-Clamps

Quick Action	204–205
--------------------	---------

Feeler

Gauge	249
-------------	-----

Fencing

Pliers	202
--------------	-----

Fencing Equipment

Barrier Mesh	56
Fence Bars	214
Pliers	202
Star Pickets & Caps	364
Tie Wire	364

Fibre

Discs – Abrasive	124
Washer – Kit	291

Fibre Core

Wire Rope	298
-----------------	-----

Fibreglass

Body Filler	456
Cleaner	450–451
Fire Blanket	46
Hammers	222, 224–226
Ladders	359–361
Lagging Rope	457
Lagging Tapes	457
Repair Kit	457
Shovels	239
Tape Measures	241

Filament

Tape	349
------------	-----

Files

Chainsaw	220
Flat	220
Half Round	220
Needle	220
Round	220
Sets	220
Thread	275

Fillers

Car Body	456
Fibreglass	456
Gap	463
Welding Wire	102

Film

Builders	364
Stretch Wrap	351

Filters

4WD Kits	385
Airline	503
Airline Regulators	504
Cartridge	22–23
Fuel	431
Respirators	22–23
Retainers	23

Finding

Paste	454
-------------	-----

Finger

Sanding Pads	125
--------------------	-----

Finishing

Abrasive Discs	125
----------------------	-----

Fire

Blanket	46
Extinguisher	46
Extinguisher – Accessories	46–47
Hose Nozzles	47
Hose Reel	47
Hose Reel Cabinets	47
Safety Signs	54

Fire Retardant

Clothing Guide	75
Coveralls	76
Coveralls – Disposable	77
Pants	76
Shirts	76
Welding Protective Clothing ...	11, 94–95

First Aid

Deluge Showers	36–37
Eye/Face Wash	35–37
Kits	33–34
Safety Signs	54
Thermometer	244

Fitting

Compound	454
----------------	-----

Fittings – Hose

Airline	493
Brass	494
Clamps	484, 486
Claw	483
Connectors – Welding	115
Elbows	494
Flare	496
Hose Tails	483, 494
Nitto Style	493
Nut & Tail	115
Olives	481
Push-In	492
Stainless Steel	494
Swivel	481
Tees	494



FITTINGS-PIPE – GARDENING EQUIPMENT

Fittings – Pipe

Brass	495–496
Bush Adaptors	495–497, 499
Elbows	495, 497–498
Flanges	506
Hex Sockets	495–496
Nipples	495, 498–499
Olives	496
Sockets	498–499
Stainless Steel	497–498
Steel	498
Steel – 600–1,000lbs	498–499
Tees	495, 497–498
Unions	498–499

Fittings – Tube

Brass	496
Elbows	492
Olives	496
Push-In	492
Tees	492
Unions	492

Flagging

Tape	337
------------	-----

Flags

Aerial Whip	58
Bunting	56

Flame Resistant

Clothing Guide	75
Coveralls	76
Coveralls – Disposable	77
Pants	76
Shirts	76
Welding Protective Clothing ...	11, 94–95

Flammable Liquids

Storage Cabinet	320
-----------------------	-----

Flange

Blind	506
Bolting American Standard	534
Bolt & Stud Dimensions	533
Gaskets	459
Plate – Slip-On	506
Sealant	466–467

Flap

Discs	125
Wheels	123

Flare Fittings

Brass	496
-------------	-----

Flare Nut

Spanners	194, 197
----------------	----------

Flaring Tool

Pipe/Tube	212
-----------------	-----

Flashback

Arrestors	112
-----------------	-----

Flashlights

Flexible	374
Head Lamp	373
Torches	373–374

Flat

Chisel	216
Files	220
Lifting Sling	296
Washers	285

Flaw Finding

Crack Detection	455
Dye	455
Finding Paste	454

Flexible

Handles – Socket Wrench	188
-------------------------------	-----

Flexgauges

Plastic	249
---------------	-----

Flints

Lighter	118
---------------	-----

Floats

Aluminium	341
Bullfloats	341
Magnesium	341
Wood	341

Flogging

Spanners	197
----------------	-----

Floodlights

Halogen	376
Portable	376
Rechargeable	376
Remote Area Lighting System	343, 376

Floor

Creepers	390
Drill Press	141
Engine Crane	388
Fans	331
Jacks	388
Sanding Paper	128
Saws	343
Stand	55

Floor Cleaners

Brooms & Sweepers	405–406
Brushes	404
Degreasers	401–402
Detergents	401
Mops	406–407
Squeegee	406

Floorsweep

Spill Control	40
---------------------	----

Flow

Meters & Regulators	109, 433
---------------------------	----------

Fluid

Transmission	440
--------------------	-----

Flush

Engine	453
Radiator	453

Flux

Brazing	117
Core Solder	117
Core Wire	102
Soldering	117

Fly & Insect

Repellent	413
-----------------	-----

Foam

Applicator Gun	468
Expanding	463
Tape	348

Foil

Aluminium Tape	347
----------------------	-----

Food Grade

Anti-Seize	436
Lubricants	442
Penetrants	444

Food Handling

Hair Net	79
----------------	----

Footwear

Covers	79
Gaiters	79
Gumboots	82–83
Laces	89
Safety Boots – Elastic-Sided	84–85
Safety Boots – Lace-Up	86–87
Safety Boots – Pull-On	89
Safety Boots – Zip-Up	87–88
Safety Shoes	89
Socks	89

Forged

Anvil	333
Fittings – Material Specification	532

Fork

Oil	439
-----------	-----

Forklift

Concrete Spreader	318
Cylinder Trolley	313
Drum Lifter	314
Extension Slippers	317
Jib	317
Pallet Stacker	317
Storage Cage	318–319, 321
Work Platform	318

Frames

Paint Roller	357
Welding Screen	96

Fuel

Cans	393–394
Control Nozzle	431
Filter	431
Flashback Arrestors	112
Hose	480
Hose Assembly	482
Hose Reels	477
Meter	433
Pumps	429–430, 432
Refuelling Kit	430
Spill Control	38–39, 41–42
Storage & Dispensing Kits	431
Transfer Pumps	430
Treatment	452–453

Full-Face

Respirators	21
-------------------	----

Funnels

Plastic	395
---------------	-----

Furniture

Castor Wheel	315
Polish	402

Fuse

Kits	381
------------	-----



Gaffer

Tape	347
------------	-----

Gaiters

Leg Protectors	79
----------------------	----

Gallon

Conversion Chart	525
------------------------	-----

Galvanising

Paint	355–356
-------------	---------

Gap

Filler	463
--------------	-----

Garbage

Bins	408–409
------------	---------

Garden

Hose Reel	476
-----------------	-----

Gardening Equipment

Backpack Sprayer	343
Blowers	155, 343
Brushcutter	154
Chainsaws	152–153
Lawnmowers	155
Pruners	153
Rake	239
Shovels	239

Trimmers	153–154	Glands	Machinery Key	521
Wheelbarrows	316	Cable	O-Rings	520
Gas		Glass	Woodruff Key	521
Butane Torch	115	Cleaners	Graphite	
Cylinder Storage	321	Cleaners – Methylated Spirits	Gasket Material	459
Cylinder Trolleys	313	Magnifying	Powder	444
Flashback Arrestors	112	Scraper	Grass	
Heating Tips	110–111	Glasses	Lawnmower	155
Hose Reels	477	Accessories	Trimmer	154
Welding Regulators	108–109	Cleaners & Wipes	Grease	
Welding Tips	110	Safety	Anti-Seize	435–436
Gas – Cutting		Safety – Bi-Focal	Bearing	436
Tips & Nozzles	113–114	Safety – Polarised	Bearing Blue	454
Gasket		Glen 20	Control Valves	422
Flange	459	Surface Spray	Couplers	422–423
Jointing Compound	463	Glide	Guns	417–418
Paper	459	Saws – Electric	High Pressure	436–437
Rubber Corks	459	Globes	High Temperature	436–437
Rubber Insertion	457	Halogen	Hose Reels	477
Scraper	229	Gloves	Hoses	424
Sealant	466–467	Chemical Resistant	Lithium	436–437
Sealing Tape	466	Clip	Marine	437
Seal – Rubber	483	Cotton	Nipples	423–424
Sheet	459	Cut Resistant	Pumps	419–422
Silicone	466–467	Disposable	Rubber	436
Steam	459	General Purpose	Transfer Pumps	419–420
Gate		High Visibility	Grease Fittings	
Valves	501	Impact	Couplers	422–423
Gauges		Kevlar	Easy Out Tools	424
Adaptors – Hydraulic	476	Latex	Extensions	424
Angle – Torque	190	Leather	Nipples	423–424
Bore	248	Leather – Synthetic	Thread Tester	424
Centre	248	Mechanics	Grease Guns	
Conversion Chart	524	Nitrile	Air Operated	418
Depth	248	Nitrile Coated	Booster	422
Dial	246	Oil Resistant	Control Valves	422
Feeler	249	Powder-Free	Cordless	418
Flexi	249	PVC Coated	Extensions	424
Magnetic Stand	246	Riggers	High Pressure	417
Manifold	385	Rubber	Kits	417
Pressure	502–503	Rubber Coated	Lever Handle	417–418
Pressure – Hydraulic	476	Thermal	Push Type	417
Pressure – Tyre	391	Welding	Trigger/Pistol Handle	417
Protractors	248	Glow	Grease Pumps	
Screw Cutting	248	Sticks	Air Operated	419–421
Surface	246	Glues	Drum	419
Thread Pitch	249	Adhesive	Electric	422
Thread Tester – Grease Fitting	424	Goggles	Foot Operated	421
Twist Drill	248	Safety	Kits	420–421
Wire	248	Welding	Lever Operated	421
Gauntlet		Goods	Transfer	419–420
Gloves	5	Storage Cage	Grinders	
G-Clamps		Wrecking Bars	Angle – Cordless	134–136
Heavy Duty	204	Gooseneck	Angle – Electric	138
Welding	107	Wrecking Bars	Angle – Pneumatic	146
Gear		Gouging	Bench – Electric	139
Lubricant	443	Arc Torch	Die – Electric	139
Oil	440	Carbon Rods	Die – Pneumatic	146
Puller	212	Tips & Nozzles	Grinding	
Winch	311	Grab	Compounds	448
Gel		Hooks – Lifting	Discs	122
Hand Cleaners	399	Grab Kits	Mounted Points	123
Insect Repellent	413	Circlips	Wheels	122–123
Generator		E-Clips	Grips	
Changeover Switches	326	Extension & Compression Spring	Wire Rope	298
Diesel	325	Fasteners	Grommets	
Petrol	324	Fuse – Automotive	Brass	363
Welder	101	Grommets	Wiring & Blanking	381
Girder		Hose & Pipe Fittings	Groove	
Trolleys	303		Ball Bearing	510



GROOVE JOINT – HELMETS

INDEX

Groove Joint

Pliers 203

Grout

Backing 364
Saw Blades 254

Grub

Screws 287
Screws – Assortment Kits 292

Guide

Roller – Cutting 114

Gumboots

Non-Safety 82
Steel Toe 82–83

Guns

Air Duster 358
Blow 150
Caulking 468
Engine Cleaning – Pneumatic ... 150, 358
Fuel Control 431
Fuel Transfer 430
Grease 417–418
Grease Control Valves 422
Heat – Electric 144
Lighter – Flint 118
Needle – Pneumatic 149
Oil Control 428
Riveter 238
Spray Paint 358
Staple 238
Suction 428
Welding 103

H

Hacksaws

Blades 252
Heavy Duty 227
Junior 227

Hair Net

Disposable 79

Half-Face

Respirators 21–22

Half-Round

Files 220

Halogen

Floodlights 376
Globes 379

Hammer Drills

Bits 262
Cordless 134–135
Drivers – Cordless 134–135
Rotary – Cordless 135
Rotary – Electric 140

Hammers

Anti-Vibration 222
Ball Pein 223
Ball Pein – Non-Sparking 223
Chipping 118
Chisel – Pneumatic 150
Claw 222
Club 224–225
Copper Head/Face 224–225
Dead Blow 225
Demolition – Electric 140
Mallet 226
Normalised 223, 225
Nylon 226
Rubber 226

Scaffold 362
Sledge 224–225
Slide 392
Soft-Face 225–226
Star Dropper 364
Welding 118

Hand

Trolleys 313
Winch 311

Hand Cleaners

Citrus 399
Gel 399
Grit 399
Heavy Duty 399

Handles

Broom/Mop 407
Bullfloat 341
Marking Paint 354
Socket 188–190

Hand Protection

Barrier Cream 400
Gloves 2, 4–8, 10–11
Safety Signs 54

Hand Tools

Barrel Drifts 218
Benders 212
Chisels 216
Clamps 204–205
Crowbars 214
Cutters 209–212, 228
Edgers 342
Engineers Kit 248
Fence Bars 214
Files 220
Files – Thread 275
Floats 341
Hammers 222–226
Hex Keys 233–235
Kits 163–165
Lanyards 33
Multi-Tools 229
Picks & Hooks 240
Pick-Up Tools 240
Pliers 200–204, 207–208
Podger Bars & Pins 215
Pry Bars 214–215
Punches 216–219
Rake 239
Riveter 238
Saws 227
Scissors 208
Scrapers 229, 358
Scrapers – Bearing 240
Screeds 341
Screwdrivers 230–232
Scribers 240, 249
Shovels 239
Snips 209
Spanners 192–197
Staple Gun 238
Torque Wrenches 191
Trowels 342
Utility/Safety Knives 228
Vee Joints 341
Wrecking Bars 215
Wrenches 192–199
Wrenches – Podging 188
Wrenches – Socket 190

Hand Trolleys

Cargo 313
Cylinder 313
General Purpose 313
Pallet Truck 317

Platform 313
Scissor Lift 313
Stairclimber 313

Hard Hats & Caps

Accessories 27
Bump Caps 27
High Visibility 27
Safety 27

Hardman Workwear

Drill Wear 63–64, 66–68
Jackets 69
Polo Shirts 68
Shirts 66–67
Socks 89
Wet Weather 69–70, 72
Women's 63

Harness

Full Body 28–29, 31
High Visibility 28–29, 31
Kits 31

Hasps

Lockout 49

Hats

Hard Hats 27
Sun 27

Hazard

Safety Lights 58
Safety Tape 56–57

Hazardous Goods

Spill Control 39–40, 42
Storage Cabinets 320–321

Head

Lamps 373

Headband

Earmuffs 26

Headlights

Vehicle 377–378

Head Protection

Bump Caps 27
Face Shields 18
Hard Hats 27
Safety Signs 54

Hearing Protection

Earmuffs 26
Earplugs 25
Safety Signs 54

Heat

Gun – Electric 144

Heater

Electrode 106

Heating

Tips & Nozzles 110–111

Hedge

Trimmer 153

Height Safety

Accessories 31–32
Anchors 31–32
Confined Space Equipment 28–29
Harnesses 28–29
Kits 31–32
Lanyards 31, 33
Lifelines 32–33
Rope 32

Helicopter

Trowel Machine 342

Helmets

Bracket – Visor 18
Hard Hats 27
Welding 93

Hex			
Drive – Power Bits	236–237		
Fittings – 600–1,000lbs	499		
Fittings – Brass	495–496		
Fittings – Stainless Steel	497–498		
Keys	233–235		
Hex Head			
Bolts	279–281		
Bolts – Stainless Steel	281		
Nuts	283		
Nuts – Nyloc	284		
Nuts – Stainless Steel	283		
Set Screws	281		
High Pressure			
Ball Valves	501		
Cleaners	410–411		
Grease Guns	417–418		
Grease Pumps	421–422		
High Tensile			
Bolts	279–281		
Chain	308		
Fasteners – Kits	289, 291–292		
Nuts	283		
Socket Head Cap Screws	286		
High Visibility			
Body Harnesses	28–29, 31		
Bump Caps	27		
Bunting Flags	56		
Coveralls	64, 77, 79		
Earmuffs	26		
Earplugs	25		
Gloves	4, 6, 8		
Hard Hats	27		
Jackets	69		
Pants	63, 72		
Pants – Insect Repellent	74		
Polo Shirts	68		
Shirts	66–68		
Shirts – Insect Repellent	73		
Tape	57		
Vests	80		
Hitch			
Pins – Assortment Kits	293		
Hoists			
Chain	303		
Lockout Cover	52		
Vehicle	389		
Holders			
Button Die	270		
Electrode	106–107		
Socket	189		
Holesaws			
Arbors	266		
Cutters	266		
Hollow			
Plunger – Hydraulic Cylinders	472		
Punches	218		
Hones			
Cylinder	386		
Hood			
Welding	94		
Hooks			
Barrel	300		
Carbine	306		
Drum	300		
Extension Lead	368		
Grab	301		
Karabiner	306		
Lifting	300–302		
Self-Locking	301–302		
Shortening	301		
Snap	306		
Turnbuckles	306		
Horizontal			
Plate Clamp	304		
Horn			
Air	59		
Horse Power/Kilowatt			
Conversion Chart	524		
Hose			
Air	479–480, 482		
Air & Water	477, 479–480, 482		
Assemblies	482		
Clamps	486		
Couplings	483		
Delivery	480–482		
Fire	47		
Fuel/Oil	477, 480–482		
Garden	476		
Grease	424, 477		
Hydraulic	475		
Layflat	480		
Nozzles – Fire	47		
Nylon	481		
Oil	477, 480		
Oxy/Acetylene	477		
PVC	479–480, 482		
Radiator	480		
Reels	476–477		
Rubber	480–482		
Self-Store	481		
Suction & Delivery	479, 481		
Water	476, 479–480		
Welding – Rubber	114		
Whipchecks	484		
Hose Fittings			
Airline	493		
Brass	494, 496		
Clamps	484, 486		
Claw	483		
Connectors – Welding	115		
Elbows	494		
Flare	496		
Hose Tails	483, 494		
Nitto Style	493		
Nut & Tail	115		
Olives	481		
Push-In	492		
Reference Charts	488		
Self-Store	481		
Stainless Steel	494		
Swivel	481		
Tees	494		
Hose Reels			
Air	476		
Air/Water	477		
Bare	478		
Fire	47		
Fire – Cabinet	47		
Fuel	477		
Garden	476		
Grease	477		
Oil	477		
Oxy/Acetylene	477		
Retractable	476		
Water	476		
Welding	477		
Hose Tail			
Brass	494		
Camlocks	484–485		
Claw Couplings	483		
Fittings – Airline	493		
Fittings – Hose	494		
Stainless Steel	494		
Housing			
Bearing Seals	514		
Plummer Block	514		
Hull			
Surface Cleaners	450		
Hydration			
Bottled Water	413		
Coolers	412		
Hydraulic			
Couplers	475		
Cylinders	472–473		
Dust Caps	475		
Engine Crane	388		
Fittings & Adaptors	488, 491		
Grease Couplers	423		
Hoses	475		
Oil	441		
Pipe & Tube Benders	333		
Press	333		
Pressure Gauges	476		
Pump	473–474		
Riveter – Pneumatic	150		
Sealant	467		
Torque Wrenches	474–475		
Vehicle Jacks	387–388		
Hydrometer			
Battery	385		
I			
IBC			
Oil Transfer Kit	428		
Spill Containers & Covers	45		
Storage Container	319		
Ice			
Bricks	412		
Cooler Chests	412		
Identification			
Padlock	49		
Tags	52–53		
Impact			
Drill – Electric	140		
Drivers – Cordless	135		
Driver Set	190		
Gloves	8		
Sockets	166–171		
Sockets – Adaptors	171		
Sockets – Set	166–167		
Wrench – Cordless	135–136		
Wrench – Pneumatic	147–148		
Imperial/Metric			
Conversion Chart	526		
Incinerator			
Contaminated Waste Disposal	43		
Indicator			
Lights	378–379		
Inflator			
Tyre	391		
Information			
Safety Tags	52		
Infrared			
Thermometer	244		



INHEX – KITS

INDEX

Inhex

- Sockets 183–184
- Sockets – Sets 183

Inhibitors

- Rust & Corrosion 443, 445, 453

Injector

- Cleaner 452

Ink

- Ballmarker 354

Inner

- Bearings 513

Insect Repellent

- Aerosol 413
- Coveralls – Fire Retardant 76
- Jeans 74
- Lanterns 413
- Pants 74
- Pants – Fire Retardant 76
- Roll-On 413
- Shirts 72–73
- Shirts – Fire Retardant 76
- Socks 89

Insert

- Thread 275

Insertion

- Rubber 457

Inside

- Calipers 246
- Micrometers 247

Inspection

- Borescope 244
- Finding Paste 454
- Fitting Compound 454
- Flaw Detection 455
- Lights 375–376
- Mirror 240
- Particle 455
- Tachometer 244
- Tags 53, 305

Instant

- Adhesive 460

Insulated

- Cutters 210
- Pliers 201–203, 207–208
- Screwdrivers 231–232
- Tool Kits 163

Insulation

- Tape 347

Internal

- Circlips 520

Inverter

- Welder 100

Iron

- Soldering 116

Isopropyl

- Alcohol – Wipes 400

J

Jackets

- PVC 70
- Welding 94
- Wet Weather 69–70

Jacks

- Bottle 387
- Floor 388
- Stands 387

- Transmission 388

Janitorial

- Pressure Cleaners 410–411
- Trolley 409
- Vacuum Cleaners 409
- Wet Floor Stand 55

Jar

- Battery 385

Jeans

- Insect Repellent 74

Jenny

- Calipers 245

Jerry

- Fuel Can 393–394

Jib

- Forklift 317

Jigsaws

- Blades 253
- Electric 143

Jimmy

- Bars 214

Jobber

- Drill Bits 258–260
- Drill Bits – Set 259–260

Joiners

- Camlock 485
- Fittings – Brass 494
- Fittings – Stainless Steel 494
- Hose – Welding 115

Jointer

- Vee 341

Jointing

- Compound 463

Joints

- Universal 189
- Universal – Square Drive 171

Jugs

- Oil 394
- Water 412

Jump

- Leads 384
- Starters 383

K

Karabiner

- Hooks 306

Kernmantle

- Rope 32

Kevlar

- Gloves 2, 11, 95

Keys

- Bottle – Oxy/Acetylene 118
- Hex 233–235
- Machinery 521
- Scaffolding 362
- Steel 521
- Woodruff 521

Kibble

- Concrete Spreader 318

Kilogram/Pound

- Conversion Chart 526

Kilopascal/PSI

- Conversion Chart 528

Kilowatt/Horse Power

- Conversion Chart 524

King Tony

- Blow Guns 150
- Chisels & Sets 216
- Circuit Tester 369
- Compressors – Ring & Spring 213
- Cutters 209–211
- Feeler Gauges 249
- Hammer Chisel – Pneumatic 150
- Hammers 223–226
- Handles – Sockets 188–190
- Hex Keys 233–235
- Multimeters 370, 372
- Nutsetters 237
- Parts Tray 162
- Picks & Hooks 240
- Pick-Up Tools 240
- Pliers & Sets 200–204, 207–208
- Power Bits & Sets 236–237
- Pry Bars 214
- Pullers & Separators 212
- Punches 216–219
- Ratchets 187–188
- Riveter 238
- Saws 227
- Scissors 208
- Scrapers 229
- Screwdrivers & Sets 230–232
- Snips 209
- Sockets 166–171, 179–186
- Sockets – Adaptors 171, 189–190
- Sockets – Sets 166–167, 172–173, 179, 183–184
- Socket Wrench – Sets 173–178
- Spanners & Sets 192–197
- Thermometer 244
- Tool Boxes 160, 162
- Tool Chests 161
- Tool Kits 163–165
- Tool Kits – Sockets 172–173
- Tool Trolleys 161
- Torches & Flashlights 373
- Tyre Lever 392
- Utility/Safety Knives 228
- Voltage Tester 370
- Work Bench 158
- Work Lights 375
- Wrenches 198–199
- Wrenches – Pneumatic 147–148
- Wrenches – Ratchet Podging 188
- Wrenches – Torque 191
- Wrenches – Wheel Nut 392

Kitchen

- Sealant 464

Kits

- Automotive Body Repair 385
- Automotive Bulbs 379
- Circlips 520
- Diesel Storage & Dispensing 431
- Drum Pumps 420–421
- E-Clips 520
- Fasteners – Bolts, Screws & Nuts 289
- Fasteners – Clips 293
- Fasteners – Grub Screws 292
- Fasteners – Nuts 293
- Fasteners – Nuts & Bolts 290
- Fasteners – Pins 293
- Fasteners – Rivets 292–293
- Fasteners – Screws & Nuts 289–290
- Fasteners – Self-Tapping Screws 292
- Fasteners – Socket Screws 291
- Fasteners – Stainless Steel 290, 292–293
- Fasteners – Washers 290–291

Fibreglass Repair 457
 First Aid 33–34
 Fuse – Automotive 381
 Grease Dispensing 420–422
 Grease Gun 417
 Grease Nipples 423–424
 Grommets 381
 Hose Clamps 486
 Hose & Pipe Fittings 496
 Lockout/Tagout 49–50
 Machinery Key 521
 O-Ring 520
 Paint Roller 357
 Pipe Repair 446
 Power Tools – Cordless 134–135
 Power Tools – Pneumatic 146, 150
 Refuelling 430
 Respirator 22
 Spill Control 41–42
 Springs 363
 Thread Repair 275
 Tool Bag 163
 Tool Box 163–164
 Tool Chest 164–165
 Tools – Electricians 163
 Tools – Sockets 172–173
 Tool Trolley 165
 Transport Chain 308
 Tyre Repair 385
 Vehicle Recovery 311
 Vehicle Spray Gun 358
 Welding & Cutting 115–116
 Wire Crimps 381
 Wire Terminal 381
 Woodruff Key 521

Knee Pads
 Welding – Leather 95

Knife
 Utility/Safety 228

L

Laces
 Boot 89

Lace-Up
 Steel Toe Boots 86–87
 Steel Toe Shoes 89

Lacquer
 Thinners 451

Ladders
 Aluminium 359–362
 Extension 361
 Fibreglass 359–361
 Platform 361
 Safety Step 359
 Scaffold 362
 Step 359–360

Lamps
 Automotive 58–59
 Beacons 58–59
 Hazard Lights 58
 Head 373

Lanolin
 Lubricant 442
 Release Agent 444

Lantern
 Batteries 382
 Torch 374

Lanyards
 Elasticated 31
 Height Safety 31, 33
 Tool 33

Lapping
 Compound 448

Laser
 Measures 243
 Rangefinder 243
 Thermometer 244

Latex
 Gloves 10–11

Lathe
 Bench 332
 Toolbits 267

Lawnmowers
 Petrol Powered 155

Layflat
 Hose 480

Lazy Tong
 Riveter 238

Lead
 Pencil 352

Leads – Electrical
 Extension 368
 Jumper 384
 Multimeter 370
 Welding Sets 107

Leaf
 Blower 155

Leather
 Apron – Welding 95
 Blanket – Welding 96
 Gloves 7–8
 Gloves – Synthetic 8
 Gloves – Welding 11, 95
 Hood – Welding 94
 Jacket – Welding 94
 Knee Pads – Welding 95
 Nailbag 162
 Protectant 402

LED
 Automotive Lights 58–59, 377–379
 Floodlights 376–378
 Head Lamps 373
 Torches 373–374
 Work Lights 375–376

Length
 Conversion Chart 526

Lens
 Cleaners & Wipes 17
 Welding 93

Letter & Number
 Punches 219
 Stencils 354

Levels
 Angle 242
 Digital 242, 244
 Laser 243
 Magnetic 242
 Spirit 242
 Tripod 244

Lever
 Blocks 303
 Loadbinders 309
 Tyre 392

Lever Handle
 Grease Guns 417–418
 Oil Pumps 426

L-Handles
 Socket 188

Licence Plate
 Light 378

Lifelines
 Horizontal 32
 Self-Retracting 32–33

Lifter
 Drum 314

Lifting
 Blocks 303
 Bulker Bag 319
 Chain 299
 Chain Hoists 303
 Eyes – Concrete 302
 Forklift Jib 317
 Hooks 300–302
 Inspection Tags 305
 Links 300
 Plate Clamps 304
 Shackles 304–305
 Slings 296–299
 Snatch Blocks 304
 Wire Rope 298

Lifting Slings
 Chain 299
 Endless Round 296
 Flat 296
 Wire Rope 297–298

Lighter
 Flint 118

Lights
 Automotive 58–59, 377–379
 Automotive Mounts & Accessories .. 379
 Beacons 58–59
 Flexible 374
 Flood Beam 377–378
 Floodlights 343, 376
 Globes & Bulbs 379
 Glow Sticks 58
 Hazard 58
 Head Lamps 373
 Indicator 378–379
 Inspection 375–376
 Lantern 374
 LED 58–59, 375–379
 Licence Plate 378
 Lighting Tower 343
 Rechargeable 375–376
 Reflectors 377
 Reversing 378–379
 Torches 373–374
 Work Light 375–376

Lime Scale
 Remover 451

Line
 Trimmers 154

Line Marking
 Machine 354
 Paint 354

Linesman
 Pliers 201–202

Linishing
 Belt Attachment 139
 Bench Grinder 139

Links
 Connecting 300
 Master Oblong 300

Liquid Nails
 Adhesive 461



LITHIUM – METAL

- Lithium**
Grease 436–437
- Litre**
Conversion Chart 525
- Load**
Ramp 312
Resistors 380
Skate 316
Testers 383
- Loadbinders**
Lever 309
Ratchet 309
- Lobby**
Dust Pan & Broom Set 405
- Locking**
Coupling Pin 483
Pliers 203–204
- Locknuts**
Nylon Insert 284
Stainless Steel 284
- Lockout**
Boxes 50
Cable 51
Circuit Breaker 51
Electrical Plug 52
Hasps 49
Hoist Cover 52
Kits 49
Padlocks 48–49
Stations 50
Tags 50, 52–53
Valve 51
- Locks**
Padlocks 48–49, 365–366
- Loctite**
Adhesives 460–461
Anti-Seize 435
Fixmaster 456
Gasket Sealant 466–467
Primer 462
Retaining Compounds 462
Steel Compound/Putty 456
Threadlocker 468
Thread Sealant 467
- Lollipop**
Road Signs 55
- Long Nose**
Pliers 201–202
- LPG**
Cutting Tips 113
Heating Tips 111
Heating Torch Kit 111
Regulators 108
- Lubricants**
Air Tool 441
Anti-Corrosion 443
Anti-Seize 435
Chain 441–443
Cutting 448
Dry 444
Electrical 443
Engine 437
Food Grade 442
Grease 436–437
Grinding 448
Hydraulic Oil 441
Lanolin 442, 444
Lapping 448
Marine 442–443
Multi-Purpose 442–443
Penetrants 444
- Release Agent 444
Silicone 442
Spray 442–443
WD-40 442
Wire Rope 443
- Lubrication Equipment**
Chemical Pumps 429, 432
Diaphragm Pumps 432
Drum Pumps 419–421, 425–427, 429–430
Filters 431
Flow Meters 428, 433
Fuel Pumps 429–430, 432
Grease Control Valves 422
Grease Couplers 422–423
Grease Gun Fittings 422–424
Grease Guns 417–418
Grease Guns – Cordless 418
Grease Hoses 424
Grease Pumps 419–422
Nozzles 431
Oil Cans 394
Oil Control Guns 428
Oil Pumps 425–429, 432
Refuelling Kits 430
Storage & Dispensing Kits 431
Transfer Pumps 428, 430
- Lubricator**
Airline 504
- Lugs**
Cable 381
- Lump**
Hammers 224
- M**
- Machine**
Pulleys 514
Vices 334
- Machinery**
Key 521
- Machining**
Toolbits 267
- Magnesium**
Floats 341
- Magnetic**
Base Drill 141
Particle Inspection 455
Parts Tray 162
Pick-Up Tool 240
Spirit Levels 242
Stand – Dial Gauge 246
- Magnification**
Safety Glasses 15
- Magnifying**
Glass 352
- Mallet**
Rubber 226
- Manifold**
Gauge Set 385
- Marine**
Adhesive 466
Body Filler 456
Engine Oil 439
Gear Oils 440
Grease 437
Lubricants 442–443
Spill Control 42
Surface Cleaners 450
- Markers**
Chalk 354
Ink 354
Paint 353
- Marking**
Machine 354
Paint 354
Scribers 240, 249
- Masking**
Tape 347
- Masks**
Disposable 20
Filters 22–23
Respirators 20–22
Welding Helmets 93
- Masonry**
Cutting Wheels 121
Drill Bits 262
- Mass**
Conversion Chart 526
- Master**
Oblong Links 300
- Mastic**
Profiling 464
- Measuring Equipment**
Angle Levels 242
Bevels 250
Borescope 244
Cable Tester 369
Calipers 245–246
Circuit Tester 369
Curv-O-Mark 118
Digital Levels 244
Digital Scanner 244
Dividers 245–246
Gauges 246, 248–249
Gauges – Dial 246
Gauges – Surface 246
Laser Measures 243
Measuring Jugs 394
Micrometers 247
Multimeters 370–372
Plumb Bob 242
Protractors 248
Rangefinders 243
Rulers 241, 250
Spirit Levels 242
Squares 250
Tachometer 244
Tape Measures 241–242
Thermometer 244
Tool Sets 248
Voltage Tester 370
- Measuring Tapes**
Dipping 242
Fibreglass 241
Open Reel 241
Stainless Steel 241
- Mechanics**
Floor Creepers 390
Gloves 7
Vices 336
- Mesh**
Barrier 56
Face Shield 18
- Metal**
Bench Lathe 332
Cleaner 444, 451
Cutting Lubricants 448
Polish 402, 444

- Meters**
Clamp 372
Flow 433
Fuel 433
Multimeter 370–371
Multimeter Leads 370
Oil 433
- Methylated**
Spirits 451
- Metric**
Imperial Conversion Chart 526
Tapping Drill Size Chart 528–529
- Microfibre**
Cloths 403
- Micrometers**
Digital 247
Inside 247
Outside 247
Sets 247
- MIG Welding**
Contact Tips 103
Machines 98–99
Pliers 118
Regulator & Flowmeter 109
Torches 103
Wire 102
- Millimetre/Inch**
Conversion Chart 526
- Milling**
Drill Machine 141
- Mills**
Saw 153
- Mine Marking**
Paint 354
Paint – Handles 354
- Mineral**
Turpentine 451
- Mining**
Hose Assemblies 482
- Mirror**
Inspection 240
- Mist**
Blower 343
- Mitre**
Saws – Electric 142
Saws – Stand 143
- Mitre Box**
Saws 227
- Mixers**
Concrete 340
Paint 358
Welding & Heating 111
- Mop**
Bucket 407–408
Dust 405
Handle 407
Head 406–407
Squeeze 406
- Mosquito**
Repellent 413
- Motor**
Electric 519
- Motorcycle**
Engine Oil 437, 439
Gear Oils 440
Grease 437
- Mounted Point**
Abrasive 123
- Mowers**
Lawnmower 155
- Multimeters**
Analogue 370
Clamp 372
Digital 370–372
Leads 370
- Multipliers**
Torque 191
- Multi-Process**
Welding Machines 98–101
- Multi-Tools**
Attachments 144, 254
Electric 143
Pliers 229
- N**
- Nail**
Bag 162
Punches 217
- Neckband**
Earmuffs 26
- Needle**
Files 220
Scalers – Pneumatic 149
- Newton-Meter**
Conversion Chart 524
- Nibblers**
Electric 143
- Nickel**
Anti-Seize 435
- Nipples**
Brass 495
Fittings 495, 498
Fittings – 600–1,000lbs 499
Grease 423–424
Grease – Thread Tester 424
Stainless Steel 498
- Nitrile**
Gloves 10–11
Gloves – Coated 4–6
- Nitrogen**
Regulators 109
- Nitto Style**
Fittings 493
- Non-Slip**
Safety Tape 57
- Non-Sparking Tools**
Hammers 223, 225
- Nordlock**
Washers 285
- Normalised**
Ball Pein Hammers 223
Sledge Hammers 225
- Nozzles**
Anti-Spatter Dip 118
Caulking 468
Cutting 113
Fire Hose 47
Fuel Control 431
Heating 110
Tip Cleaner 118
- NPT**
Pipe Specifications 532
Tapping Drill Size Chart 529
- Number & Letter**
Punches 219
Stencils 354
- Nuts**
Assortment Kits 289–290, 293
Brass 496
Die 271–272
Fittings 496
Hex 283
High Tensile 283
Material Specifications 534
Nyloc 284
Stainless Steel 283–284
Wrenches 392
- Nutsetters**
Power Bits 237
- Nut & Tail**
Fittings – Brass 115
- Nyloc**
Nuts 284
Nuts – Stainless Steel 284
- Nylon**
Castors 316
Hammers 226
Hose 481
Rods 364
Tube 481
- O**
- Oblong**
Links 300
- Office Products**
Digital Scales 352
Magnifying Glass 352
Paint Markers 353
Scissors 352
Tape 347–349
- Offset**
Spanners 192, 196–197
Tin Snips 209
Vices 335–336
- Offshore & Oilfield**
Non-Sparking Hand Tools 223, 225
- Oil**
2-Stroke 437, 439
4-Stroke 439
Air Tool 441
Cans 394
Chain 441
Compressor 441
Control Gun 428
Drainers 393
Engine 437–439
Fork 439
Gear 440
High Pressure 440
Hose 480–481
Hose Reels 477
Hydraulic 441
Jugs 394
Marine 439–440
Meter 433
Pourers 394
Pressure Gauges 503
Pressure Tester 386
Pumps 425–428, 432
Spill Control 38–39, 41–42
Transfer Kits 428
Transmission Fluid 440



OLIVES – PICKET

INDEX

Olives

Brass	496
Kits	496
Nylon	481

Open End

Spanners	194, 196
----------------	----------

Open Reel

Tape Measures	241
---------------------	-----

Optical

Levels	244
--------------	-----

Orbital

Sanders – Cordless	137
Sanders – Electric	145
Sanders – Pneumatic	150

O-Ring

Kits	520
------------	-----

Oscillating

Tool – Electric	143
-----------------------	-----

Ounce/Kilogram

Conversion Chart	526
------------------------	-----

Outlet

Earth Leakage	369
Power Boards	369

Outside

Calipers	246
Micrometers	247

Oven

Electrode Heater	106
------------------------	-----

Overalls

Chemical Resistant	77, 79
Disposable	77, 79
Drill	64
Fire Retardant	76–77
High Visibility	64, 77, 79
Insect Repellent	76

Overpacks

Drum	43
------------	----

Overwrap

Tape	446
------------	-----

Oxy/Acetylene

Bottle Key	118
Cutting Tips & Nozzles	113–114
Hose Connectors	115
Hose Reels	477
Hose – Welding	114
Welding & Cutting Kits	115–116

Oxygen

Flashback Arrestors	112
Regulators	108–109
Welding Goggles	93
Welding Tips	110

P

Packaging

Bubble Wrap	352
Paper	352
Strapping & Accessories	349–350
Stretch Film	351
Tape	349

Packing

Compression	458
Emission	458
Extractors	458
Scales	352

Padlocks

Brass	365–366
Combination	365
Deadbolt	366
Heavy Duty	366
Identification	49
Lockout	48–49
Lockout Kits & Stations	49–50
Puck	366
Stainless Steel	365

Pads

Disc Backing	124
Sanding	124–125
Scourers	404
Spill Control	38–39
Urinal	403

Pails

Plastic	408
Rubber	408
Steel	408

Paint

Anti-Corrosive	355–356
Anti-Slip	356
Brushes	356
Cleaner	451
Cold Galvanising	355
Line Marking	354
Markers	353
Mine Marking	354
Mixer	358
Primers	355
Rollers	357
Scrapers	229, 358
Silver	355
Spray Guns	358
Stencils	354
Stripper	451
Thinner	451
Zinc	355–356

Painters

Respirators	22
-------------------	----

Painting Equipment

Brushes	356
Line Marking Handle	354
Line Marking Machine	354
Rollers & Frames	357
Roller Tray	357
Scrapers	358

Pallet

Cage	318
Spill	44–45
Spill Covers	44–45
Stacker – Forklift	317
Strapping & Tools	349–350
Stretch Film	351
Truck	317

Palm

Router – Electric	143
-------------------------	-----

Panel Beater

Set	385
-----------	-----

Pants

Cargo	74
Drill	63–64
Fire Retardant	76
Insect Repellent	74, 76
Jeans	74
PVC	70
Rain	70, 72
Reflective	63, 72, 74
Shorts	64
Women's	63

Paper

Brown Packing	352
Gasket	459
Sand	127–128

Parallel

Bore – Bearings	511
-----------------------	-----

Parrot

Pliers	202
--------------	-----

Particle

Inspection	455
------------------	-----

Particulate

Filters	22–23
Respirators	20

Parts

Cleaners	450
Storage Bins	319
Tray – Magnetic	162
Washing Tanks	331

Paste

Finding	454
Pickling	117
Soldering	117

Patrol

Site Boxes	158
------------------	-----

Pedestal

Fans	331
------------	-----

Pen

Engraving	150
Paint Markers	353
Torch	373

Pencil

Carpenters	352
------------------	-----

Penetrants

Corrosion/Rust	442
Food Grade	444
Release Agent	444
Rust & Corrosion	444

Pest Control

Insect Repellent	413
------------------------	-----

Petrol

Air Compressors	330
Containers	393–394
Drive Units	340
Engine Oils	438–439
Engines	326
Fuel Treatment	452–453
Generators	324
Hose	480
Water Pumps	326

Petrolatum

Tape	446
------------	-----

Petrol Powered Tools

Blowers	155, 343
Brushcutter	154
Demolition Breakers	342
Drills – Earth Auger	152
Lawnmowers	155
Plate Compactors	338
Pruners	153
Saws – Chainsaws	152–153
Saws – Cut-Off	152
Trimmers	153–154

Phillips

Power Bits	236–237
Screwdrivers	232
Sockets	186

Photo

Tachometer	244
------------------	-----

Picket

Caps	364
Star	364

Pick & Hook		Funnels	395	Pointed	
Sets	240	Protectant	402	Trowel	342
Pickle		Storage Container	319	Poker	
Paste	117	Syphon Pumps	432	Concrete Vibrator	340
Pick-Up		Plate		Polarised	
Tools	240	Clamps	304	Safety Glasses	15
Pillows		Compactors	338	Pole	
Spill Control	38–39	Flange	506	Pruners	153
Pilot		Sanding	125	Strap	32
Pins	265	Platform		Polish	
Pins		Ladders	361	Automotive	402
Assortment Kits	293	Packing Scales	352	Furniture	402
Cotter	293	Trolleys	313	Metal	402, 444
Hitch	293	Work – Forklift	318	Polishers	
Pilot	265	Pliers		Sanders – Cordless	136
Podger	215	Circlip	201, 203	Sanders – Electric	145
Roll	293	Combination	201–202	Polkadot	
Split	293	Diagonal Cutting	201, 207	Gloves	2
Pinch		End Cutting	207	Polo Shirts	
Bars	214	Fencing	202	High Visibility	68
Pinchweld		Groove Joint	203	Poly	
Scraper	229	Insulated	201–203, 207–208	Castors	316
Pins		Linesman	201–202	Storage Bags	319
Locking – Couplings	483	Locking	203–204	Strapping	349
Punches	217–218	Long Nose	201–202	Wheelbarrows	316
Pipe		MIG Welding	118	Polyester	
Benders	333–334	Miniature	201	Lifting Slings	296
Cutters	210–211	Multi-Grip	203	Rope	308
Dies	274	Multi-Tool	229	Polyethylene	
Measure – Curv-O-Mark	118	Sets	200–201	Builders Film	364
Solvent Cement	462	Wire Stripping & Crimping	208	Tarpaulins	363
Stand	336	Plugs		Tube	481
Threader	274	Airline	493	Polypropylene	
Thread Specification	532–533	Dinse	108	Rope	308
Vices	336	Drum Wrench	199	Polyurethane	
Wrenches	198–199	Dust – Camlock	485	Sealants	465–466
Pipe Fittings		Earplugs	25	Poncho	
Brass	495–496	Electrical – Lockout	52	Disposable	72
Bush Adaptors	495–497, 499	Fittings	495, 498	Postage	
Elbows	495, 497–498	Fittings – 600–1,000lbs	499	Bubble Wrap	352
Flanges	506	Stainless Steel	498	Packing Paper	352
Hex Sockets	495–496	Surge Protected	368	Packing Tape	349
Nipples	495, 498–499	Plumb		Scales	352
Olives	496	Bob	242	Pound/Kilogram	
Sockets	498–499	Plumbing		Conversion Chart	526
Stainless Steel	497–498	Fibre Washer – Assortment Kits	291	Pourers	
Steel	498	Sealant	465	Funnels	395
Steel – 600–1,000lbs	498–499	Solder Bars	117	Oil	394
Tees	495, 497–498	Thread Sealing Tape	348	Powder	
Unions	498–499	Plummer		Graphite	444
Pipe Repair		Block Housings – Bearing	514	Powder-Free	
Bandages	446	Plunge		Gloves	10
Primers	445	Saw Blades	254	Power	
Pistol		Pneumatic Tools		Boards	369
Grease Gun	417	Drills	147	Boards – Earth Leakage Unit	369
Piston		Engraving Pen	150	Drive Units	340
Oil Pumps	426	Grinders – Angle	146	Generators	324–325
Ring Compressor	213	Grinders – Die	146	Plugs	368
Pitch		Guns – Blow	150	Power Bits	
Reference Table	527	Guns – Engine Cleaning	150	Hex Head	236–237
Planer		Hammer Chisel	150	Nutsetters	237
Cordless	136	Kits	146, 150	Phillips Head	236–237
Electric	144	Needle Scalers	149	Pozidriv	237
Plasma Cutting		Riveter	150	Sets	237
Machines	101	Sanders – Orbital	150	Slotted	236–237
Parts & Accessories	114	Shears	149	Square Head	236–237
Plastic		Wrenches – Impact	147–148	Torx Head	237
Bucket	319, 408	Wrenches – Ratchet	148		
Castor – Furniture	315	Podger			
Chain	307	Bars	215		
		Pins	215		
		Wrenches – Ratchet	188		



Powercoil

- Thread Inserts275
- Thread Repair Kits275

Power Tools

- Batteries & Chargers137
- Cordless – Angle Grinders134–136
- Cordless – Drill/Drivers134–135
- Cordless – Hammer Drills134–135
- Cordless – Impact Drivers135
- Cordless – Impact Wrench135–136
- Cordless – Kits134–136
- Cordless – Orbital Sanders137
- Cordless – Planer136
- Cordless – Reciprocating Saws136
- Cordless – Rotary Hammers135
- Cordless – Sander/Polishers136
- Cordless – Screwdriver136
- Electric – Angle Grinders138
- Electric – Bench Grinders139
- Electric – Circular Saws142
- Electric – Cut-Off Saws142
- Electric – Demolition Hammers140
- Electric – Die Grinder139
- Electric – Drill Press141
- Electric – Glide Saw142
- Electric – Heat Gun144
- Electric – Impact Drills140
- Electric – Jigsaws143
- Electric – Magnetic Base Drills141
- Electric – Mitre Saw142
- Electric – Multi-Tools143
- Electric – Nibblers143
- Electric – Orbital Sanders145
- Electric – Palm Router143
- Electric – Planer144
- Electric – Rebar Bender/Straightener144
- Electric – Rebar Cutters144
- Electric – Rotary Hammers140
- Electric – Sander/Polishers145
- Electric – Table Saw142
- Petrol – Blower155, 343
- Petrol – Brushcutter154
- Petrol – Chainsaws152–153
- Petrol – Cut-Off Saws152
- Petrol – Demolition Breaker342
- Petrol – Earth Auger Drill152
- Petrol – Grass Trimmers154
- Petrol – Hedge Trimmers153
- Petrol – Pole Pruners153
- Pneumatic – Angle Grinders146
- Pneumatic – Die Grinders146
- Pneumatic – Drills147
- Pneumatic – Hammer Chisels150
- Pneumatic – Impact Wrench ...147–148
- Pneumatic – Kits146, 150
- Pneumatic – Needle Scalars149
- Pneumatic – Orbital Sanders150
- Pneumatic – Ratchet Wrench148
- Pneumatic – Riveter150
- Pneumatic – Shears149

Power Transmission

- Key Steel521
- Machinery Key521
- V-Belts516–517
- Woodruff Key521

Pozidriv

- Power Bits237
- Screwdrivers232

Press

- Drill – Bench141
- Drill – Floor141
- Hydraulic333

Pressure

- Conversion Chart528
- Gauges391, 502–503
- Gauges – Hydraulic476
- Regulators108–109
- Tester386
- Test Pump503

Pressure Cleaners

- Cold Water410–411
- Commercial411
- Electric410–411
- Engine Powered411
- Hot Water411

Pressure Gauges

- Back Entry502–503
- Bottom Entry476, 502–503
- Hydraulic476
- Liquid Filled502–503
- Stainless Steel502–503
- Tyre391

Primer

- Adhesive & Sealant462
- Cold Galvanising355
- Denso445
- Paint355

Profiling

- Mastic464

Proof Coil

- Chain307

Propane

- Welding & Cutting Kit116

Protectants

- Leather402
- Metal402
- Pipe Tape445–446
- Plastic/Vinyl402
- Rust & Corrosion445

Protective Clothing

- Aprons79
- Chaps80
- Coveralls77, 79
- Gaiters79
- Hair Net79
- Shoe Covers79

Protective Clothing – Welding

- Apron95
- Gloves11, 95
- Goggles93
- Helmets & Masks93
- Hood94
- Jacket94
- Knee Pads95

Protractors

- Depth Gauge248

Pruners

- Petrol Powered153

Prussian Blue

- Grease454

Pry

- Bars214–215

PSI/Kilopascal

- Conversion Chart528

Puck

- Padlock366

Pullers

- Bearing212
- Gear212
- Wire Rope Cable303

Pulleys

- V-Pulleys514

Pull-On

- Steel Toe Boots84–85, 89

Pumice

- Hand Cleaner399

Pumps

- Air Operated419–421, 427–428, 432
- Battery Powered427
- Chemical429, 432
- Diaphragm432
- Drum419–421, 425–427, 430
- Electric427, 430
- Fuel429–430, 432
- Grease419–422
- Hydraulic473–474
- Lever Handle426
- Oil425–428, 432
- Plastic432
- Pressure Test503
- Rotary426, 429
- Spout429
- Stub427
- Submersible341
- Syphon432
- Tank427
- Torque Wrench474
- Transfer419, 428, 432
- Trash327
- Vane427, 430
- Water – Diesel326
- Water – Petrol326

Punches

- Centre216–217
- Hollow218
- Letter/Number219
- Nail217
- Pin217–218
- Starter217
- Wad218

Push-In

- Tube Fittings492

Push Type

- Grease Gun417

Putty

- Repair456–457

PVC

- Aprons79
- Gloves – Coated10
- Gumboots82
- Hose479–480, 482
- Pants70
- Priming Fluid462
- Rain Coats & Jackets70
- Solvent Cement462
- Tape – Double Sided348
- Tape – Insulation347
- Tape – Overwrap446
- Tarpaulins363



Qcut

- Annular Cutters265
- Blades – Circular251
- Blades – Hacksaw252
- Cut-Off Wheels121
- Drill Bits – Jobber259
- Drill Bits – Step263
- Fibre Discs124
- Flap Wheels123

Grinding Wheels 122
 Magnetic Base Drills 141
 Pilot Pins 265
 Sanding Paper & Belts 127–128
 Screw Extractors 267
 Utility/Safety Knives 228
 Wire Wheels 127

R

Radar
 Universal Detector 244

Radiator
 Cleaners 453
 Hose 480
 Solder 117
 Stop Leak 454

Rafters
 Square 250

Rags
 Cleaning 403

Rain Wear
 Coats 70
 Jackets 69
 Pants 70, 72
 Poncho 72

Rakes
 Garden 239

Rammers
 Tamping – Diesel 339
 Tamping – Petrol 339

Ramps
 Container 312
 Vehicle 389

Random
 Orbital Sanders – Cordless 137
 Orbital Sanders – Electric 145
 Orbital Sanders – Pneumatic 150

Rangefinder
 Laser 243

Rapp-it
 Pipe Repair Bandage 446

Ratchet
 Cutting Pliers 210
 Flaring Tool 212
 Loadbinder 309
 Podging Wrench 188
 Repair Kit 187
 Reversible 187–188
 Screwdrivers 231
 Socket 187–188
 Spanners 192, 195
 Tie-Down Strap 311
 Wrenches – Pneumatic 148

R-Clips
 Assortment Kits 293

Reamers
 Machine 264

Rear Wheel
 Socket 171

Rebar
 Bender/Straightener 144
 Cutter/Bender 212
 Cutters 144

Rechargeable
 Torches 374
 Work Lights 375

Reciprocating Saws
 Blades 253
 Cordless 136

Recovery
 Creeper 303
 Track – Vehicle 390
 Winch 311
 Winch Kits 311

Reduced Shank
 Drill Bit 260

Reducers
 Brass 495
 Fittings 497, 499
 Nipples 495, 499
 Sleeve 261
 Stainless Steel 497
 Steel 499

Reels
 Barrier Tapes 57
 Electrical Leads 368
 Hose – Air 476
 Hose – Air/Water 477
 Hose – Bare 478
 Hose – Fire 47
 Hose – Fuel 477
 Hose – Grease 477
 Hose – Oil 477
 Hose – Oxy/Acetylene 477
 Hose – Water 476
 Tape Measure 241–242

Reference Information
 Conversion Charts 524–528
 Hose Fittings 488
 Lifting Chain Care & Use 299
 Lifting Chain Working Load 299
 Material Specifications 531–532, 534
 Mechanical Properties 531

Reflective
 Coveralls 64, 76
 Gloves 8
 Pants 63, 72, 74, 76
 Polo Shirts 68
 Rain Jackets 69
 Rain Pants 72
 Shirts 66–68
 Shirts – Insect Repellent 72–73
 Tape 57
 Traffic Cones & Bollards 55–56
 Vests 80

Reflectors
 Automotive 377

Refuelling
 Kit 430

Regulators
 Acetylene 108–109
 Argon 109
 Filter 504
 Flowmeter 109
 LPG/Propane 108
 Nitrogen 109
 Oxygen 108–109
 Welding 108–109

Relay
 Resistors 380

Release Agent
 Lubricant 444

Removers
 Calcium, Lime & Rust 451
 Rust 451
 Star Dropper 364
 Wax 451

Repair
 Automotive Body Kit 385
 Body Filler 456
 Fibreglass 457
 Pipe Bandages 446
 Putty 456–457
 Ratchet Kit 187
 Tape 348
 Thread Kits 275
 Tyre 385

Repellent
 Insect 413

Rescue
 Kit 32

Resin
 Solder 116

Resistors
 Load 380
 Relay 380

Respirators
 Cupped 20
 Disposable 20
 Filters 22–23
 Flat Fold 20
 Full-Face 21
 Half-Face 21–22
 Kits 22
 Particulate 20
 Reusable 21
 Safety Signs 54
 Valved 20
 Welding 22

Restrooms
 Cleaners 451
 Signage 54

Retainers
 Respirator Filters 23

Retaining
 Compounds 462
 Springs & Clips 520

Reversible
 Drill – Pneumatic 147

Reversing
 Alarm 380
 Lights 378–379

Ribe Bit
 Sockets 186

Riggers
 Gloves 8

Ring
 Spanners 192, 196–197

Riveters
 Hand Tools 238
 Lazy Tong 238
 Pneumatic 150

Rivets
 Assortment Kits 292–293
 Nut Inserts 293

Road
 Cones 55
 Lighting Tower 343
 Safety Signs 54–55
 Traffic Control 55–56

Rod
 Allthread 288
 Allthread – Stainless Steel 288
 Brazing 106
 Bronze 364
 Cutter/Bender 212
 Gouging Carbons 108

**ROD – SCISSORS**

- Nylon 364
- Welding 104, 106
- Roll**
- Pins – Assortment Kits 293
- Spill Control 38–39
- Roller**
- Bearings 511–512
- Chain 519
- Guide – Cutting 114
- Load Skates 316
- Paint 357
- Paint Kits 357
- Paint – Tray 357
- Stud Extractor 213
- Tool Cabinets 161
- Tool Cabinets – Kits 165
- Vibratory 339
- Roof**
- Anchor 32
- Roofers**
- Safety Kit 31
- Roof & Gutter**
- Sealant 465
- Rope**
- Anchor 32
- Braided 308
- Fibreglass Lagging 457
- General Purpose 308–309
- Grips – Wire Rope 298
- Kernmantle 32
- Polyester 308
- Polypropylene 308
- Silver 309
- Thimbles – Wire Rope 298
- Twisted 308
- Winch Kits 311
- Wire 298
- Wire – Slings 297–298
- Rotabroach**
- Cutters 265
- Pilot Pins 265
- Rotary**
- Hammers – Cordless 135
- Hammers – Electric 140
- Pumps – Chemical 429
- Pumps – Fuel 429
- Pumps – Oil 426, 429
- Round**
- Files 220
- Flat Washers 285
- Slings – Lifting 296
- Router**
- Palm – Electric 143
- Rubber**
- Backing Pads 124
- Bucket 408
- Castors 316
- Cork – Gasket 459
- Gloves 10
- Gloves – Coated 2, 5, 7
- Grease 436
- Grommets 381
- Gumboots 83
- Hose 480–481
- Hose Assembly 482
- Hose – Welding 114
- Insertion 457
- Mallet 226
- Protectant 402
- Seal Gasket 483
- Wheel Chocks & Stop 390
- Rubbish**
- Bins 408–409
- Rulers**
- Plastic Folding 241
- Stainless Steel 241
- Rust**
- Converters 444
- Inhibitors 443, 445
- Penetrants 444
- Removers 444, 450–451
- S**
- Sabre Saws**
- Blades 253
- Safety**
- Aerial Whip 58
- Anti-Slip Paint 356
- Anti-Slip Products 57
- Aprons 79
- Beacon Lights 58–59
- Boots 84–89
- Earmuffs 26
- Earplugs 25
- Eye/Face Wash 35–37
- Face Shields 18
- Fire Safety 46–47
- First Aid Kits 33–34
- Gaiters 79
- Glasses 13–15
- Gloves 4–8, 10–11
- Gloves – Welding 11, 95
- Goggles 16–17
- Gumboots 82–83
- Hard Hats & Caps 27
- Harnesses 28–31
- Head Lamps 373
- Height Safety Equipment 28–29, 31–33
- Knives & Blades 228
- Ladders 359–361
- Locking Pins 483
- Lockout/Tagout 48–53
- Respirators 20–22
- Showers 36–37
- Signs 47, 54–55
- Spill Control 38–45
- Step/Stools 359
- Storage Cabinets 320–321
- Storage Cages 321
- Tags 50, 52–53
- Tape 56–57
- Traffic Control 55–57
- Vehicle Reflectors 377
- Welding Blanket 96
- Welding Body Protection 94–95
- Welding Gloves 95
- Welding Goggles 11, 93
- Welding Helmets & Masks 93
- Safety Pin**
- Shackles – Lifting 305
- Saline**
- Eyewash 35
- Sample**
- Bags 319
- Sanders**
- Bench – Electric 139
- Orbital – Cordless 137
- Orbital – Electric 145
- Orbital – Pneumatic 150
- Polishers – Cordless 136
- Polishers – Electric 145
- Sanding**
- Belts 128
- Block 128
- Discs 124–125
- Finishing Attachment 139
- Pads 124, 144
- Paper 127–128
- Tool Attachments 124–125, 144
- Saturn**
- Chain 307–308
- Chain Blocks 303
- Commercial Hooks 306
- Commercial Shackles 305–306
- Girder Trolleys 303
- Lever Blocks 303
- Lifting Slings 296–297
- Loadbinders 309
- Load Skates 316
- Plate Clamps 304
- Slings 298
- Tie-Down Strap 311
- Turnbuckles 306
- Winches 311
- Wire Rope 298
- Wire Rope Creepers 303
- Wire Rope Grips 298
- Wire Rope Thimbles 298
- Sawmills**
- Chainsaw 153
- Saws**
- Band 343
- Blades 251–253
- Blades – Multi-Tool 144, 254
- Brick 342
- Chainsaws – Petrol Powered ... 152–153
- Circular – Electric 142
- Cut-Off – Electric 142
- Cut-Off – Petrol Powered 152
- Floor Saw 343
- Glide – Electric 142
- Hacksaws 227
- Hand Saws 227
- Holesaws 266
- Jigsaws – Electric 143
- Mitre Box 227
- Mitre – Electric 142
- Reciprocating – Cordless 136
- Table & Stand 143
- Scaffold**
- Hammer 362
- Inspection Report Book 362
- Key 362
- Tags 53
- Towers & Accessories 362
- Scalers**
- Needle – Pneumatic 149
- Scales**
- Packing 352
- Scaling**
- Bars 215
- Scanner**
- Universal Detector 244
- Scissor Lift**
- Trolley 313
- Scissors**
- Electricians 208
- General Purpose 208, 352
- Industrial 208
- Snips 209

- Scourers**
 Cleaning 404
 Sponges 404
 Stainless Steel 404
- Scrapers**
 Bearing 240
 Bent 229
 Gasket 229
 Paint 229, 358
 Pinchweld 229
 Window 229
- Screeds**
 Concreting 341
- Screen**
 Welding 96
- Screw**
 Cutting Gauge 248
 Extractors 267
- Screwdrivers**
 Drywall – Cordless 136
 Impact Driver – Set 190
 Insulated 231–232
 Phillips 232
 Pozidriv 232
 Precision 230
 Sets 230–231
 Slotted 232
 Torque 231
- Screw Pin**
 Shackles – Lifting 304–305
- Screws**
 Assortment Kits 289–292
 Grub 287, 292
 Pan Head 292
 Self-Tapping 292
 Set Screws – Stainless Steel 281
 Socket 286–287
- Scribers**
 Picks & Hooks 240
 Steel 249
 Surface Gauge 246
- Scrubbing**
 Brush 404
- SDS**
 Document Storage 52
 Drill Bits 262
 Hammer – Cordless 135
- Sealants**
 Caulking Guns & Applicators 468
 Compression Packing 458
 Electrical 464
 Emission Packing 458
 Gap Fillers 463
 Gasket 459, 466–467
 High Temperature 465
 Marine 466
 Polyurethane 465–466
 Primer 462
 Profiling Mastic 464
 Roof & Gutter 465
 Silicone 464–465
 Thread 467
 Waterproof 464–466
 Windscreen 466
- Sealing**
 Tapes 347–348
- Seals**
 Bearing Housing 514
 Buna Ring 485
 Container Bolt 308
- O-Rings 520
 Strapping 350
 V-Ring 514
- Security**
 Padlocks 365–366
 Padlocks – Lockout 48–49
 Signage 52–54
- Segmented**
 Diamond Blades 251–252
 Saw Blades 254
- Self-Retracting**
 Lifelines 32–33
- Self-Store**
 Hose 481
 Hose Fittings 481
- Self-Tapping**
 Screws – Assortment Kits 292
- Sets**
 Annular Cutters 265
 Blades – Circular Saw 251
 Carbide Burrs 254–255
 Chisels 216
 Drill Bits – Jobber 259–260
 Drill Bits – Reduced Shank 260
 Drill Bits – Step 263
 Engineers Tools 248
 Files 220
 Hex Keys 233–235
 Holesaws 266
 Impact Socket Driver 190
 Pipe Dies 274
 Pipe Threader 274
 Pliers 200–201
 Power Bits 237
 Pry Bars 214–215
 Punches 216–219
 Reamers 264
 Riveting Tools 238
 Screwdrivers 230–231
 Screw Extractors 267
 Seal – Bearing Housing 514
 Sockets 179
 Sockets – Bit 183–184
 Sockets – Impact 166–167
 Sockets – Inhex 183
 Socket Wrench 173–178
 Socket Wrench – Angled 190
 Spanners 192–194
 Tap & Die 273
 Tap & Drill 272
 Thread Insert 275
 Thread Repair 275
 Thread Taps 270
 Torque Wrench 191
- Set Screws**
 Assortment Kits 289
 Stainless Steel 281
- Shackles**
 Bow – Commercial 305–306
 Bow – Lifting 305
 Dee – Commercial 305
 Dee – Lifting 304–305
- Shaft**
 Adaptor Sleeves 513
- Sharpening**
 Bench Stone 129
- Shears**
 Pneumatic 149
- Sheave**
 Blocks 304
- Sheet**
 Gasket 459
 Rubber 457
- Shields**
 Visor 18
 Visor – Accessories 18
- Shim**
 Brass 521
 Steel 521
- Shirts**
 Drill 66–68
 Fire Retardant 76
 High Visibility 66–68, 72–73
 Insect Repellent 72–73, 76
 Polo Shirts 68
 Women's 73
- Shoes**
 Cleaner – Boots Brush 404
 Covers 79
 Gumboots 82–83
 Laces 89
 Safety Boots 84–89
 Safety Shoes 89
- Shopping**
 Trolley 313
- Shortening**
 Clutches 301
 Hooks 301
- Short Link**
 Chain 307
- Shorts**
 Drill Wear 64
- Shovels**
 Drainage 239
 Fibreglass 239
 Garden 239
- Shower**
 Accessories & Parts 37
 Cleaners 451
 Eye/Face Wash Units 36–37
- Signal**
 Air Horn 59
- Signs**
 Fire Equipment 47
 Safety 54–55
 Traffic Control 54–55
 Wet Floor 55
- Silicone**
 Gasket 466–467
 Lubricants 442
 Sealants 464–465
 Tape 348
- Silver**
 Paint 355
 Rope 309
- Siren**
 Emergency Warning 59
- Site**
 Boxes 158–159
 Lighting Tower 343
- Size**
 Conversion Chart 526
- Skate**
 Load 316
- Slag**
 Hammer 118
- Sledge**
 Hammers 224–225

**SLEEVE – STAINLESS STEEL**

Sleeve	Screws – Countersunk	287	Spirit	Levels	242
Adaptor – Bearings	Sets	166–167, 179	Methylated	451	
Anchor Bolts	Sets – Bit	183–184	Splicing	O-Ring Cord	520
Cut Resistant	Sets – Inhex	183	Spline Head	Hex Keys	234
Drill – Taper Shank	Sets – Socket Wrench	173–178	Sockets	Sockets – Sets	184–185
Slide	Slotted Bit	186			
Hammer	Spark Plug	186	Split	Pins – Assortment Kits	293
Sliding	Speed Brace	189	Sponge	Mops	406
T-Handles – Socket	Spline Head	184–185	Scourer	404	
Slings	Star	184–185	Spoon	Bars	214
Anchor	Tool Kits	172–173	Spot Marking	Handle	354
Slings – Lifting	Torx	184–185	Machine	354	
Chain	Wrenches	188	Paint	354	
Chain Load Limit Chart	Wrenches – Angled	190	Spout	Rotary Pump	429
Endless Round	Socks		Spray	Cleaners	401–402
Flat	Bamboo	89	Insect Repellent	413	
Hooks	Work	89	Paint	354–356	
Wire Rope	Solder		Paint – Applicator	354	
Slip-On	Bars	117	Paint – Guns	358	
Flanges	Brazing Rods	106	Protectants	402	
Slippers	Flux Core	117	Sprayer	Backpack	343
Forklift Extension	Resin Core	116	Paint – Guns	358	
Slogging	Soldering		Spring	Compression	363
Spanners	Flux	117	Dividers	245	
Slot Drills	Irons	116	Extension	363	
Drill Bits	Pickling Paste	117	Ring Compressor	213	
Slotted	Solvents		Washers	285	
Power Bits	Acetone	451	Square	Carpenters	250
Screwdrivers	Cement Adhesive	462	Combination	250	
Sockets	Mineral Turpentine	451	Drive – Power Bits	236–237	
Slow	Paint Stripper	451	Engineers	250	
Road Signs	Thinners	451	Layout Tool	250	
Smokers	Solvol		Trowel	342	
Ashtray	Soap	399	Try	250	
Snake	Spades		Squeegees	Floor	406
Gaiters	Drainage	239	Stabiliser	Diesel Fuel	452
Snake Bite	Fibreglass	239	Stackable	Storage Container	319
First Aid Kit	Garden	239	Stacker	Pallet Truck	317
Snap Hooks	Spanners		Stainless Steel	Bow Shackles	305–306
Stainless Steel	Combination	192–196	Buckets	408	
Snatch	Flare Nut	194, 197	Buckles	487	
Blocks	Open End	194, 196	Carbine Hooks	306	
Strap	Ratchet	192, 195	Chain	307	
Snips	Ring	192, 196–197	Cleaners	402, 451	
Aviation	Sets	192–194	Cutter – Tube	211	
Tin	Slogging	197	Dee Shackles	305	
Soap	Spark Plug		Edgers	342	
Bar	Sockets	186	Electrodes	104	
Liquid	Spectacles		Feeler Gauges	249	
Soapstone	Accessories	15	Fittings	494, 497–498	
Holder	Cleaners & Wipes	17	Grips – Wire Rope	298	
Sockets	Safety	13–15	Hose Clamps	486	
Adaptors	Speed		Padlocks	365	
Chrome	Limit Signs	55			
Deep	Speed Brace				
Dinse	Socket	189			
Extractors	Spherical				
Fittings – 600–1,000lbs	Roller Bearings	511			
Fittings – Brass	Spill Control & Containment				
Fittings – Stainless Steel	Absorbent Granules	40			
Handles	Absorbent – General Purpose	38			
Impact	Absorbent – Hazchem	39–40			
Impact Driver – Sets	Absorbent – Oil & Fuel	38–39			
Inhex	Bunds	43–44			
Phillips Bit	Drain Covers	40			
Ratchets	IBC	45			
Ribe Bit	Kits	41–42			
Screws	Trays & Containers	43–45			
Screws – Assortment Kits	Waste Disposal	42–43			
	Wipes	40			

Rulers	241	Step	Steel	349
Scourers	404	Drill Bits	Tensioner	350
Snap Hooks	306	Ladders	Stretch	
Strapping Band	487	Safety	Film Wrap	351
Swivels	306	Stick	String	
Thimbles – Wire Rope	298	Glow Light	Bricklayers Line	337
Turnbuckles	306	Stick Welding	Stripper	
Vee Joints	341	Inverters	Paint	451
Wire Rope	298	Machines	Pliers	208
Wire Wheel Brushes	126–127	Stihl	Structural	
Stainless Steel – Fasteners		Backpack Sprayer	Adhesives	461
Allthread	288	Blowers	Stub	
Assortment Kits	290–293	Brushcutter	Pumps	427
Bolts	281	Chain Oil	Stud	
Nuts	283	Chainsaws	Extractor	213
Nuts – Nyloc	284	Circular Saws	Material Specifications	531, 533–534
Roll Pins	293	Earth Auger Drill	Submersible	
Screws – Self-Tapping	292	Engine Oil	Pumps	341
Set Screws	281	Grass Trimmer	Suction	
Split Pins	293	Hedge Trimmer	Guns	428
Washers	285	Pole Pruners	Hose	479, 481–482
Stair		Pressure Cleaners	Sump Plug	
Tread	57	Spare Parts & Service	Washer Kit	291
Stairclimber		Vacuum Cleaners	Sun Protection	
Trolley	313	Stirrer	Hard Hat Brim	27
Stands		Paint	Hats	27
Dial Gauge	246	Stone	Sunscreen	33
Electric Saw	142–143	Sharpening	Umbrella	413
Engine	388	Stool	Sunscreen	
Jack	387	Safety	Cream	33
Pipe	336	Stop	Super Glue	
Vice	336	Signs	Adhesive	460
Wet Floor	55	Stop Leak	Support Belt	
Staple		Automotive Fluid	Back	80
Gun	238	Stop-Seize	Surface	
Refill Pack	238	Copper	Cleaners	401–402, 451
Star		Nickel	Degreasers	401–402
Cutters	128	Storage	Disinfectant	400
Dropper Hammer & Remover	364	Bags	Wipes	400
Hex Keys	234	Bucket	Surface Preparation	
Pickets	364	Bulker Bags	Abrasives – Discs	124–125
Sockets	184–185	Cabinet – Dangerous Goods	Abrasives – Sanding Belts	128
Sockets – Sets	184	Cage	Abrasives – Sanding Paper	127–128
Starter		Container	Surge Protected	
Punches	217	Fuel Kits	Plugs	368
Starters		IBC Container	Power Boards	369
Cables	384	Parts Bins	Surgical	
Jump	383	SDS Document	Masks	20
Stationery		Site Boxes	Survey	
Carpenters Pencil	352	Site Boxes	Bricklayers Line	337
Chalk	354	Tool Bags	Digital Levels	244
Paint Markers	353	Tool Boxes	Flagging Tape	337
Rulers	241	Tool Boxes	Laser Measures	243
Steam		Tool Chests	Rangefinder	243
Gaskets	459	Tool Trolleys	Tripod	244
Steel		Straight	Suspension	
Bucket	408	Die Grinders – Electric	Welding Helmet	93
Fittings – Pipe	498–499	Strap	Sweepers	
Key	521	Anchor	Brooms	405–406
Shim	521	Pole	Dust Mop	405
Site Boxes	158–159	Safety Glasses	Push	405
Strapping	349	Snatch	Switch	
Tool Boxes	160	Tie-Down	Changeover – Generator	326
Wheelbarrow	316	Webbing	Swivel	
Steel Toe		Wrench	Castors	316
Gumboots	82–83	Strapping	Couplers – Grease	423
Safety Boots	84–89	Buckles – Stainless Steel	Lifting Hooks	302
Safety Shoes	89	Crimping Tool	Stainless Steel	306
Stencil		Dispenser		
Letters & Numbers	354	Poly		
		Seals & Buckles		
		Stainless Steel		



SYPHON – TORCHES

Syphon

Pumps 432

T

Table

Saws – Electric 142
Saws – Stand 142–143
Work Bench 158

Tachometer

Digital 244

Tags

Appliance 53
Identification 52–53
Information 52
Inspection 53, 305
RFID 53
Safety 50, 52–53
Scaffold 53

Tamping Rammers

Diesel 339
Petrol 339

Tank

Pumps 427, 430
Sealant 456

Tap & Die

Sets 273

Tap & Drill

Sets 272

Tape

Aluminium Foil 347
Anti-Slip 57
Cloth 347
Denso 446
Densyl 445
Double Sided 348
Duct 347
Fibreglass Lagging 457
Filament 349
Foam 348
Gaffer 347
High Visibility 57
Insulation 347
Masking 347
Measuring 241–242
Packing 349
Petrolatum 446
Pipe Repair 445–446
PVC 347–348
Reflective 57
Repair 348
Safety 56–57
Sealing – Flange 466
Silicone 348
Survey/Flagging 337
Thread Sealing 348

Tape Measures

Dipping 242
Fibreglass 241
Open Reel 241
Stainless Steel 241

Taper

Chuck Arbors 236

Tapered

Bore – Bearings 511–512

Taper Shank

Drill Bits 261
Sleeves 261

Tapping

Drill Bits 267, 270
Drill Sizes Table 528–529

Taps

Drill Bits 267, 270
Wrenches 270

Tarpaulin

Grommets 363
Polyethylene 363
PVC 363

T-Bar

Clamps 205

T-Bevel

Sliding 250

Tees

Brass 494–495
Fittings 492, 494–495, 497–498
Push-In 492
Stainless Steel 497
Steel 498

Temperature

Conversion Chart 525

Tensioner

Strapping Tool 350

Terminals

Battery 384
Wire 381

Test

Tags – Appliance 53

Testers

Battery Load 383
Cable 369
Circuit 369
Clamp Meters 372
Multimeters 370–371
Pressure 386
Thread – Grease Nipples 424
Voltage 370

Textas

Paint Markers 353

Thermal

Gloves 8

Thermometer

Infrared 244

Thimbles

Wire Rope 298

Thinners

Paint 451

Thor

Club Hammers 225

Thread

Files 275
Gauges 249
Inserts 275
Pipe Specification 532
Reference Table 527
Repair Kit 275
Sealants 468
Sealing Tapes 348
Tapping Drill Size Chart 530
Taps 267, 270

Threaded Rod

Allthread 288
Allthread – Stainless Steel 288

Threading

Dies – Button 271–272
Dies – Pipe 274
Pipe Threader 274
Tap & Die Sets 273

Threadlocker

Primer 462
Sealants 468

Tie

Cable 366–367
Wire 364

Tie-Down

Straps 311

TIG Welding

Inverters 100
Machines 98–101
Regulator & Flowmeter 109
Torches 103
Wire 102–103

Tiling

Multi-Tool Accessory Set 144

Tin

Snips 209

Tips

Packing Extractor 458

Tips – Torch

Cleaner Set 118
Contact – Welding 103
Cutting 113–114
Gouging 114
Heating 110–111
Welding 110

Titanium

Repair Putty 456

Toilet

Brush Set 403
Cleaners 451
Deodorant Blocks 403
Deodorant Pads 403

Tongs

Chain 199
Electrode Holder 107

Tool Boxes

Aluminium 159–160
Cantilever 160
Fabric 162
Plastic 160
Site Boxes 158–159
Steel 160
Vehicle 159–160

Tool Kits

Electricians 163
Sockets 172–173
Tool Bag 163
Tool Box 163–164
Tool Chest 164–165
Tool Trolley 165

Tool Storage

Cabinets 161
Chests 161
Parts Tray – Magnetic 162
Site Boxes 158–159
Tool Bags 137, 162
Tool Boxes 159–160, 162
Trolleys 161
Work Benches 158

Toolbits

Lathe 267

Torches

Arc Gouging 108
Blowpipe 112
Butane 115
Hand Held 373–374
Head Lamps 373
Heating Kit 111

- Lantern 374
LED 373–374
Pen 373
Rechargeable 374
Roller Guide 114
Welding 103
- Torpedo**
Spirit Levels 242
- Torque**
Angle Gauges 190
Multipliers 191
Screwdriver 231
Wrenches 191
Wrench – Hoses 475
Wrench – Hydraulic 474–475
Wrench – Hydraulic Pump 474
- Torx**
Hex Keys 235
Power Bits 237
Sockets 184–185
Sockets – Sets 184
- Toxic Substances**
Storage Cabinet 321
- Track**
Recovery – Vehicle 390
- Tradesmans**
Brooms 405
Rope 308
- Traffic Control**
Barrier Mesh 56
Bollards 56
Bunting Flags 56
Road Cones 55–56
Safety Signs 54–55
Triangle 55
- Trailer**
Cables 380
Tarpaulin 363
- Transfer**
Fuel Pumps 430, 432
Grease Pumps 419–420
Hose Assembly – Fuel 482
Oil Pumps 428
- Transmission**
Fluid 440
Jacks 388
- Transport**
Chain 308
Loadbinders 309
Tie-Down Strap 311
- Trash**
Bin 408–409
Pumps 327
- Trays**
Paint Roller 357
Parts 162
Spill Control 43
- Treatment**
Fuel Additives 452–453
- Triangle**
Traffic Control 55
- Trigger Handle**
Grease Guns 417
- Trimmer**
Brushcutter 154
Grass 154
Hedge 153
- Tripod**
Building & Survey 244
Remote Area Lighting System 376
- Trolleys**
Cargo 313
Cylinder 313
Drum 314
Girder – Push Type 303
Hand 313
Janitor's 409
Pallet Truck 317
Platform 313
Scissor Lift 313
Stairclimber 313
Tool 161
- Trousers**
Drill 63
Fire Retardant 76
Insect Repellent 74, 76
Jeans 74
Rain 70, 72
- Trowels**
Hand 342
Machines 342
- Truck**
Battery Chargers 382–383
Cleaners & Degreasers 402
Jacks & Stands 387–388
Jumper Leads 384
Jump Starters 383
Pallet 317
Rope 308
Tool Boxes 159–160
Tyre/Wheel Accessories 392
Winch 311
- Try**
Square 250
- T-Shaped**
Driver 190
- Tube**
Benders 333–334
Copper 487
Cutters 210–211
Cutter Wheels 211
Flaring Tool 212
Nylon 481
Polyethylene 481
Ventilation 331
- Tube Fittings**
Brass 496
Elbows 492
Hose Tails 494
Olives 496
Push-In 492
Tees 492
Unions 492
- Turnbuckles**
Commercial Grade 306
Stainless Steel 306
- Turpentine**
Mineral 451
- Twist Drills**
Gauge 248
Jobber 258–260
- Twist Knot**
Wire Wheel Brushes 126–127
- Tyre**
Balancer 389
Changers 389
Chocks & Stops 390
- Inflator 391
Lever 392
Pressure Gauges 358, 391
Recovery Track 390
Repair Kit 385
- U**
- Umbrella**
Beach 413
- UNC**
Tapping Drill Size Chart 528, 530
- UNF**
Tapping Drill Size Chart 528
- Unions**
Barrel 498
Bulkhead 492
Fittings 492, 498–499
Push-In 492
Stainless Steel 498
Steel 499
- Universal**
Joints 171, 189
- Urinal**
Deodorant Blocks 403
Deodorant Pads 403
- Ute**
Tool Boxes 159–160
- Utility**
Knives & Blades 228
- V**
- V-Pulleys**
Tapered Bore 514
- Vacuum Cleaners**
Wet & Dry 409
- Valved**
Respirators 20
- Valves**
Ball 500–501
Brass 500–501
Control 422
Drain 504
Gate 501
Grinding Compound 448
Lockout/Tagout 51
- Vane**
Fuel Pumps 430
Oil Pumps 427
- V-Belts**
Industrial 516–517
- Vee Jointer**
Concreting 341
- Vehicle**
Aerial Flag 58
Battery Chargers 382–383
Cleaners & Degreasers 402
Cranes & Hoists 388–389
Creepers 390
Electrical Parts 379–381
Filter Kits 385
Fuses & Crimps 381
Jacks & Stands 387–388
Jumper Leads 384



VEHICLE – WHIPPER SNIPPER

INDEX

- Jump Starters 383
- Lighting 58–59, 377–379
- Oil Drainer 393
- Polish 402
- Ramps 389
- Reflectors 377
- Reversing Alarm 380
- Spray Gun Kit 358
- Tool Boxes 159–160
- Trailer Cables 380
- Tyre Changers 389
- Tyre Repair 385
- Tyre/Wheel Accessories 391–392
- Wash Pad 43
- Wheel Balancer 389
- Wheel Chocks & Stops 390
- Winch 311
- Winch Kits 311

Ventilation

- Fans 331
- Tube 331

Vernier

- Calipers 245

Vertical

- Plate Clamps 304

Vests

- High Visibility 80

Vibrators

- Concrete Poker 340

Vibratory Rollers

- Double Drum 339
- Single Drum 339

Vices

- Bench 335–336
- Drill Press 334–335
- Engineers 335–336
- Machine 334
- Mechanics 336
- Offset 335–336
- Pipe 336
- Woodworkers 336

Vinyl

- Protectant 402

Visors

- Face Shields 18

Voltage

- Clamp Meters 372
- Multimeters 370–371
- Tester 370

Volume

- Conversion Chart 525

V-Ring

- Seals 514



Wad

- Punches 218

Wall

- Fans 331

Warning

- Air Horn 59
- Beacon Lights 58–59
- Hazard Lights 58
- Safety Signs 54
- Siren 59

Washers

- Assortment Kits 290–291
- Copper 291
- Fibre 291
- Flat 285
- Nordlock 285
- Parts – Machines 331
- Pressure Cleaners 410–411
- Round 285
- Spring 285
- Stainless Steel 285

Waste

- Bags – Contaminated 42
- Oil Drainer 393

Water

- Bottled/Drinking 413
- Container 412
- Coolers 412
- Demineralised 385
- Finding Paste 454
- Hose 479–480, 482
- Hose Reels 476–477
- Ice Bricks 412
- Preservative – Eyewash 35

Water Pumps

- Diesel 326
- Petrol 326
- Submersible 341
- Trash 327

Wax

- Polish 402
- Removers 451

WD-40

- Lubricant 442

Webbing

- Lifting Slings 296
- Strap 311
- Truck Winch 311

Welder

- Generator 101
- Inverters 100

Welding

- Anti-Spatter 118
- Apron 95
- Blanket 96
- Blowpipe 112
- Bottle Keys 118
- Cable 107
- Cable Connector 108
- Chipping Hammer 118
- Clamps 107, 204
- Compounds 457
- Contact Tips 103
- Curtains 96
- Cutting – Parts & Accessories 113–114
- Cylinder Trolley 313
- Dinse Plug & Socket 108
- Electrode Holders 106–107
- Electrodes 104, 106
- Flashback Arrestors 112
- Flowmeter 109
- Gloves 11, 95
- Goggles 93
- Gouging Carbons 108
- Hammer 118
- Helmets 93
- Hood 94
- Hose 114
- Hose Reels 477
- Jacket 94

- Kits 115–116
- Knee Pads 95
- Lead Sets 107
- Lenses 93
- Mask 93
- Mixers 111
- Plasma Cutters 101
- Pliers 118
- Regulators 108–109
- Respirators 22
- Rods 104, 106
- Safety Signs 54
- Screens 96
- Tips 110–111
- Torches 103, 108
- Wire 102–103

Welding Machines

- Arc/Stick 98–101
- Diesel Engine Driven 101
- Generator 101
- Inverters 100
- MIG/Multi-Process 98–99
- TIG 98–101

Wet & Dry

- Floor Sweeper 405
- Sanding Paper 127
- Vacuum Cleaners 409

Wet Floor

- Stand 55

Wet Weather

- Gumboots 82–83
- Jackets 69–70
- Pants 70, 72
- Poncho 72

Wheelbarrow

- Poly Tray 316
- Steel Tray 316

Wheelie

- Bins 409

Wheels

- Balancer 389
- Castors 315–316
- Chocks 390
- Chocks – Brackets 390
- Recovery Track 390
- Tyre Changers 389
- Tyre Gauges 391
- Tyre Inflators 391
- Tyre Levers 392
- Vehicle Ramps 389
- Wrenches 392

Wheels – Abrasive

- Depressed Centre 122
- Dressers 128
- Flap 123, 125
- Grinding 122–123
- Sanding 125
- Surface Preparation 125
- Wire 126

Wheels – Cutting

- Masonry 121
- Metal 121
- Multi-Purpose 121
- Ultra Thin 121

Whip

- Aerial Flag 58

Whipcheck

- Hose 484

Whipper Snipper

- Brushcutter 154
- Grass Trimmer 154

Wide
 Inner Bearings 513

Winch
 Hand 311
 Recovery Kits 311
 Truck 311
 Wire Rope Creepers 303

Wind Breaks
 Tarpaulin 363

Window
 Cleaners 401
 Scraper 229

Windscreen
 Adhesive/Sealant 466

Wipes
 Alcohol 400
 Antibacterial 400
 Cloth 403-404
 General Purpose 403-404
 Grease/Oil 40
 Industrial 40
 Lens Cleaners 17
 Rags 403

Wire
 Crimps 381
 Cutters 208
 Gauge 248
 Rope 298
 Rope – Slings 298
 Stripping & Crimping Pliers 208
 Terminals 381
 Tie 364
 Welding 102-103

Wire Brushes
 Cup 126-127
 Hand 126
 Twist Knot 126-127
 Wheel 126

Wire Rope
 Cable Pullers 303
 Creepers 303
 Cutters 210
 Grips 298
 Lifting 298
 Lubricant 443
 Slings 298
 Thimbles 298

Wiring
 Grommets 381

Witches Hats
 Traffic Cones 55

Women's Clothing
 Pants 63
 Shirts – Insect Repellent 73

Wood
 Chisel 216
 Cutting Blades 251, 253
 Floats 341

Wooden
 Handles – Broom/Mop 407

Woodruff
 Key 521

Woodworking
 Clamps 205
 Squares 250
 Vices 336

Work
 Benches 158
 Forklift Platform 318

Work Boots
 Covers 79
 Elastic-Sided 84-85
 Laces 89
 Lace-Up 86-87
 Pull-On 89
 Zip-Up 87-88

Work Lights
 Flood Beams 377
 Floodlights 376
 Inspection 375-376
 LED 376
 Rechargeable 375-376
 Remote Area Lighting System 343, 376

Workplace
 First Aid Kits 34

Workshop
 Air Compressors 327-330
 Anvil 333
 Band Saw 343
 Engine Cranes 388
 Engine Stand 388
 Floor Creepers 390
 Generators 324-325
 Hydraulic Press 333
 Jacks 387-388
 Lathes 332
 Parts Washers 331
 Pipe Stand 336
 Pipe & Tube Benders 333-334
 Tool Storage 161
 Tyre Changers 389
 Vehicle Hoist 389
 Vehicle Ramps 389
 Ventilation Fans & Tube 331
 Vices 334-336
 Wheel Balancer 389
 Work Benches 158
 Work Lights 375-376

Workwear
 Aprons 79
 Boots 84-89
 Coveralls 64, 76
 Coveralls – Disposable 77, 79
 Fire Retardant 76-77
 Gumboots 82-83
 Insect Repellent 72-74, 76
 Jackets 69
 Jeans 74
 Pants 63, 74, 76
 Polo Shirts 68
 Shirts 66-68, 72-73, 76
 Shoes 89
 Shorts 64
 Socks 89
 Vests 80
 Wet Weather 69-70, 72
 Women's 63, 73

Wrap
 Bubble 352
 Pipe Repair 446
 Stretch Film 351

Wrapping
 Paper 352

Wrecking
 Bars 215

Wrenches
 Adjustable 198
 Chain 199
 Combination 192-196

Drum Plug 199
 Flare Nut 194, 197
 Hex Keys 235
 Impact – Cordless 135-136
 Impact – Pneumatic 147-148
 Open End 194, 196
 Pipe 198-199
 Ratchet 192, 195
 Ratchet – Pneumatic 148
 Ratchet Podging 188
 Ring 192, 196-197
 Socket – Angled 190
 Socket – Set 173-178
 Strap 199
 Tap 270
 Torque 191
 Torque – Hoses 475
 Torque – Hydraulic 474-475
 Torque – Hydraulic Pump 474
 Wheel 392

Z

Zinc
 Paint 355-356
 Primer 355
 Stencils 354

Zip
 Ties 366-367

Zip-Up
 Steel Toe Boots 87-88